

PASCO COUNTY LEGAL NOTICES

NOTICE OF PUBLIC SALE

COLLATERAL BANKRUPTCY SERVICES, LLC gives Notice of Foreclosure of Lien and intent to sell this vehicle on August 8, 2016 at 11:00 a.m. @ 1103 Precision Street, Holiday, FL 34690, pursuant to subsection 713.78 of the Florida Statutes, Collateral Bankruptcy Services, LLC reserves the right to accept or reject any and/or all bids.

2008 Toyota
VIN: 4T1BE46K28U239317
July 22, 2016 16-02109P

NOTICE UNDER FICTITIOUS NAME LAW PURSUANT TO F.S. §865.09

NOTICE IS HEREBY GIVEN that the undersigned, desiring to engage in business under the fictitious name of Lasting Impressions, located at 29129 Johnston Rd Lot 2515, in the City of Dade City, County of Pasco, State of FL, 33523, intends to register the said name with the Division of Corporations of the Florida Department of State, Tallahassee, Florida.

Dated this 18th day of July, 2016.
Pamela S. Thomas
Donna S. Kerrick
29129 Johnston Rd Lot 2515
Dade City, FL 33523
July 22, 2016 16-02106P

FIRST INSERTION

NOTICE OF APPLICATION FOR TAX DEED 201600236 (SENATE BILL NO. 163)

NOTICE IS HEREBY GIVEN, that RMC TL 2013 LLC the holder of the following certificate has filed said certificate for a tax deed to be issued thereon. The certificate number and year of issuance, the description of the property, and the names in which it was assessed are as follows:

Certificate No. 1110774
Year of Issuance: June 1, 2012
Description of Property:
28-25-16-0040-00000-0070
PORT RICHEY ACRES SUB PB
5 PG 154 LOTS 7 & 17 OR 3266
PG 1974

Name (s) in which assessed:
CHUCK HENKEL
CHUCK J HENKEL
EVERETT E HENKEL JR
EVERETT HENKEL JR
LUCILLE ZIMMEY
LUCILLE ZIMMY

All of said property being in the County of Pasco, State of Florida.

Unless such certificate shall be redeemed according to law the property described in such certificate shall be sold to the highest bidder FOR CASH at the Clerk and Comptrollers Office 38053 Live Oak Ave, 2nd Floor on the 25th day of AUGUST, 2016 at 10:00 AM.

Dated this 11th day of JULY, 2016.
Office of Paula S. O'Neil
CLERK & COMPTROLLER
BY: Susannah Hennessy
Deputy Clerk
July 22, 29; Aug. 5, 12, 2016 16-02064P

FIRST INSERTION

Notice is hereby given that ExtraSpace Storage, LLC will sell at public auction, to satisfy the lien of the owner, personal property described below belonging to those individuals listed below at location indicated:
3118 U.S. Highway 19, Holiday FL 34691, 727-937-2975, 08/09/2016 at 10:30 AM.

Unit #017 Lynn Brownsword Household Goods
Unit #289 Christine Garland Household Goods
Unit #073 Patrice Ray Household Goods
Unit #695 Amanda Bush Household Goods
Unit #604 Kenneth A Skaggs Household Goods
Unit #321 Nadia Ahmad Hazime Household Goods
Unit #254 Jannet Dolores Fairfield Household Goods
Unit #045 David Vahan Vidal household
Unit #38 George Dedrick Brazier Furniture and household goods.
Unit #165 Carrie Marie Wood Household Goods
Unit #320 Anthony Everett Harris Jr household goods
Unit #085 Matthew Ronald Foley household goods
Unit #542 Heather Didonato Xmas decorations boxes
Unit #410 Eric Alan Robinson small furniture, beds, couches
Unit #044 James Harvey washer, dryer, fridge, 2 bedrooms

The auction will be listed and advertised on www.storagetreasures.com. Purchases must be made with cash only and paid at the above referenced facility in order to complete the transaction. ExtraSpace Storage, LLC may refuse any bid and may rescind any purchase up until the winning bidder(s) takes possession of the personal property.

June 22, 29, 2016 16-02110P

NOTICE OF PUBLICATION

To Whom It May Concern
Notice is hereby given of intention to apply to the 2017 Regular Legislative Session or subsequent sessions held in 2017 of the Florida Legislature for the passage of an act for relief of Jennifer Wohlgemuth, providing an appropriation, to compensate her for personal injuries resulting from the negligence of and Final Judgment against the Pasco Sheriff's Office. The total amount of the claim sought through the claims bill process is the amount the Pasco County Sheriff's Office agreed to pay to settle the unpaid amount of the Amended Final Judgment, to wit: \$2,600,000.

Frank Winkles, Esq.
Florida Bar No: 149760
Winkles Law Firm, P.A
707 North Franklin St. 2nd FL
Tampa Florida 33602
Attorney for the Plaintiff
July 22, 2016 16-02133P

FIRST INSERTION

NOTICE OF APPLICATION FOR TAX DEED 201600224 (SENATE BILL NO. 163)

NOTICE IS HEREBY GIVEN, that RMC TL 2013 LLC the holder of the following certificate has filed said certificate for a tax deed to be issued thereon. The certificate number and year of issuance, the description of the property, and the names in which it was assessed are as follows:

Certificate No. 1108703
Year of Issuance: June 1, 2012

Description of Property:
26-24-16-0170-00300-0114
GULF COAST ACRES UNIT 1 PB
5 PGS 84 & 85 POR OF LOTS 11 & 12 BLOCK 3 DESC AS COM AT NE COR OF NE 1/4 OF NW 1/4 OF SEC 26 TH ALG EAST LINE OF NW 1/4 S00DEG03' 05"W 588.48 FT TH N89DEG56' 55"W 30.00 FT TO POB TH S00DEG03' 05"W 200.00 FT TH N89DEG55' 56"W 325.00 FT TH N00DEG03' 05"E 200.00 FT TH S89DEG56' 55"E 325.00 FT TO POB OR 8946 PG 2896 OR 9018 PG 2565

Name (s) in which assessed:
ROBERT D HYLBERT

All of said property being in the County of Pasco, State of Florida.

Unless such certificate shall be redeemed according to law the property described in such certificate shall be sold to the highest bidder FOR CASH at the Clerk and Comptrollers Office 38053 Live Oak Ave, 2nd Floor on the 25th day of AUGUST, 2016 at 10:00 AM.

Dated this 11th day of JULY, 2016.
Office of Paula S. O'Neil
CLERK & COMPTROLLER
BY: Susannah Hennessy
Deputy Clerk
July 22, 29; Aug. 5, 12, 2016 16-02053P

FIRST INSERTION

NOTICE OF APPLICATION FOR TAX DEED 201600228 (SENATE BILL NO. 163)

NOTICE IS HEREBY GIVEN, that RMC TL 2013 LLC the holder of the following certificate has filed said certificate for a tax deed to be issued thereon. The certificate number and year of issuance, the description of the property, and the names in which it was assessed are as follows:

Certificate No. 1109539
Year of Issuance: June 1, 2012

Description of Property:
09-25-16-0770-00000-078A
BROWN ACRES WEST ADD UNREC PLAT PCL 78A BEING POR OF TR 40 OF PORT RICHEY LAND CO SUB PB 1 PG 61 DESC AS COM NW COR LOT 56 OF BROWN ACRES UNIT 2 PB 7 PG 139 TH ALG WLY EXTENSION OF N LN LOT 56 S89DEG59' 08"W 522 FT TH S00DEG00' 52"E 90 FT FOR POB TH S00DEG00' 52"E 90.85 FT TO S LN TR 40 TH ALG S LN TR 40 S89DEG56' 11"W 50 FT TH N00DEG00' 52"W 90.89 FT TH N89DEG59' 08"E 50 FT TO POB EXC SLY 1 FT THEREOF OR 6376 PG 924

Name (s) in which assessed:
DINO FOTOPULOS

All of said property being in the County of Pasco, State of Florida.

Unless such certificate shall be redeemed according to law the property described in such certificate shall be sold to the highest bidder FOR CASH at the Clerk and Comptrollers Office 38053 Live Oak Ave, 2nd Floor on the 25th day of AUGUST, 2016 at 10:00 AM.

Dated this 11th day of JULY, 2016.
Office of Paula S. O'Neil
CLERK & COMPTROLLER
BY: Susannah Hennessy
Deputy Clerk
July 22, 29; Aug. 5, 12, 2016 16-02057P

FIRST INSERTION

NOTICE OF APPLICATION FOR TAX DEED 201600246 (SENATE BILL NO. 163)

NOTICE IS HEREBY GIVEN, that PASCO HOLDINGS LLC the holder of the following certificate has filed said certificate for a tax deed to be issued thereon. The certificate number and year of issuance, the description of the property, and the names in which it was assessed are as follows:

Certificate No. 1004310
Year of Issuance: June 1, 2011

Description of Property:
36-25-19-0010-00000-2880
QUAIL HOLLOW PINES UNRECORDED PLAT LOT 288 DESC AS COM AT SE COR OF SECTION 36 TH N01DG 02' 53"E ALG EAST LINE OF SECTION 36 1429.50 FT TH N89DG 13' 15"W 1559.20 FT TO PC OF A CURVE TH WLY ALG ARC OF A CURVE RIGHT 295.65 FT TO THE PC RADIUS 2261.96 FT DELTA 07DG 29' 20" CHD BRG & DIST N85DG 28' 35"W 295.44 FT TH N81DG 43' 55"W 1787.24 FT TH N08DG 16' 05"E 491.82 FT FOR POB TH CONT N08DG 16' 05"E 151.50 FT TH S88DG 57' 07"E 292.32 FT TH S08DG 16' 05"W 151.50 FT TH N88DG 57' 07"W 292.32 FT TO POB OR 4610 PG 324

Name (s) in which assessed:
KAREN K RECKNER
RUSSELL E RECKNER
RUSSELL E RECKNER II

All of said property being in the County of Pasco, State of Florida.

Unless such certificate shall be redeemed according to law the property described in such certificate shall be sold to the highest bidder FOR CASH at the Clerk and Comptrollers Office 38053 Live Oak Ave, 2nd Floor on the 25th day of AUGUST, 2016 at 10:00 AM.

Dated this 11th day of JULY, 2016.
Office of Paula S. O'Neil
CLERK & COMPTROLLER
BY: Susannah Hennessy
Deputy Clerk
July 22, 29; Aug. 5, 12, 2016 16-02073P

FIRST INSERTION

NOTICE TO CREDITORS IN THE CIRCUIT COURT FOR PASCO COUNTY, FLORIDA PROBATE DIVISION FILE NO.

2016CP-00632 WS
IN RE: ESTATE OF
SETH E. THOMAS,
Deceased.

The administration of the estate of SETH E. THOMAS, deceased, whose date of death was January 29, 2016, is pending in the Circuit Court for Pasco County, Florida, Probate Division, the address of which is P.O. Box 338, New Port Richey, FL 34656. The names and addresses of the personal representative and the personal representative's attorney are set forth below.

All creditors of the decedent and other persons having claims or demands against decedent's estate, on whom a copy of this notice is required to be served, must file their claims with this court ON OR BEFORE THE LATER OF 3 MONTHS AFTER THE TIME OF THE FIRST PUBLICATION OF THIS NOTICE OR 30 DAYS AFTER THE DATE OF SERVICE OF A COPY OF THIS NOTICE ON THEM.

All other creditors of the decedent and other persons having claims or demands against decedent's estate must file their claims with this court WITHIN 3 MONTHS AFTER THE DATE OF THE FIRST PUBLICATION OF THIS NOTICE.

ALL CLAIMS NOT FILED WITHIN THE TIME PERIODS SET FORTH IN SECTION 733.702 OF THE FLORIDA PROBATE CODE WILL BE FOREVER BARRED.

NOTWITHSTANDING THE TIME PERIOD SET FORTH ABOVE, ANY CLAIM FILED TWO (2) YEARS OR MORE AFTER THE DECEDENT'S DATE OF DEATH IS BARRED.

The date of first publication of this notice is: July 22, 2016.

KATHERINE M. MEADOWS
Personal Representative
130 Brightwater Drive, Unit 5
Clearwater Beach, FL 34767
HARMONY J. WIDMAN, ESQUIRE
Attorney for Personal Representative
Florida Bar No. 00076735
SPN# 00317925
McFARLAND, GOULD, LYONS,
SULLIVAN & HOGAN, P.A.
311 S. Missouri Ave
Clearwater, FL 33756
Telephone: (727) 461-1111
Email:
hwidman@mcfarlandgouldlaw.com
Secondary Email:
kliebson@mcfarlandgouldlaw.com
July 22, 29, 2016 16-02091P

FIRST INSERTION

NOTICE OF APPLICATION FOR TAX DEED 201600225 (SENATE BILL NO. 163)

NOTICE IS HEREBY GIVEN, that RMC TL 2013 LLC the holder of the following certificate has filed said certificate for a tax deed to be issued thereon. The certificate number and year of issuance, the description of the property, and the names in which it was assessed are as follows:

Certificate No. 1109007
Year of Issuance: June 1, 2012

Description of Property:
34-24-16-0080-01400-0010
GARDEN TERRACE ACRES UNREC PLAT WEST 86.00 FT OF TRACT 14 DESC AS COM AT SE COR OF SW 1/4 OF SEC 34 TH ALG EAST LINE OF SW 1/4 N00DEG15' 57"E 508.00 FT TH N89DEG05' 06"W 437.91 FT FOR POB TH CONT N89DEG 05' 06"W 218.95 FT TH N00DEG16' 52"E 168.71 FT TH S89DEG04' 04"E 218.93 FT TH S00DEG16' 33"W 168.65 FT TO POB; WEST & SOUTH 25.00 FT THEREOF SUBJECT TO EASEMENT FOR PUBLIC RD R/W OR 5058 PG 310 OR 6529 PG 1200

Name (s) in which assessed:
DAN BOWLES TRUSTEE
LAND TRUST AGREEMENT
13104

All of said property being in the County of Pasco, State of Florida.

Unless such certificate shall be redeemed according to law the property described in such certificate shall be sold to the highest bidder FOR CASH at the Clerk and Comptrollers Office 38053 Live Oak Ave, 2nd Floor on the 25th day of AUGUST, 2016 at 10:00 AM.

Dated this 11th day of JULY, 2016.
Office of Paula S. O'Neil
CLERK & COMPTROLLER
BY: Susannah Hennessy
Deputy Clerk
July 22, 29; Aug. 5, 12, 2016 16-02054P

FIRST INSERTION

NOTICE TO CREDITORS IN THE CIRCUIT COURT FOR PASCO COUNTY, FLORIDA PROBATE DIVISION File No.

2016-CP-000751
Division I
IN RE: ESTATE OF
RONALD E. IRVINE,
Deceased.

The administration of the estate of RONALD E. IRVINE, deceased, whose date of death was March 12, 2016, is pending in the Circuit Court for Pasco County, Florida, Probate Division, the address of which is Clerk and Comptroller, 38053 Live Oak Avenue, Suite 207, Dade City, Florida 33523-3894. The names and addresses of the personal representative and the personal representative's attorney are set forth below.

All creditors of the decedent and other persons having claims or demands against decedent's estate on whom a copy of this notice is required to be served must file their claims with this court WITHIN THE LATER OF 3 MONTHS AFTER THE TIME OF THE FIRST PUBLICATION OF THIS NOTICE OR 30 DAYS AFTER THE DATE OF SERVICE OF A COPY OF THIS NOTICE ON THEM.

All other creditors of the decedent and other persons having claims or demands against decedent's estate must file their claims with this court WITHIN 3 MONTHS AFTER THE DATE OF THE FIRST PUBLICATION OF THIS NOTICE.

ALL CLAIMS NOT FILED WITHIN THE TIME PERIODS SET FORTH IN SECTION 733.702 OF THE FLORIDA PROBATE CODE WILL BE FOREVER BARRED.

NOTWITHSTANDING THE TIME PERIODS SET FORTH ABOVE, ANY CLAIM FILED TWO (2) YEARS OR MORE AFTER THE DECEDENT'S DATE OF DEATH IS BARRED.

The date of first publication of this notice is July 22, 2016.

BRADLEY K. IRVINE
Personal Representative
248 Dover Bluff Drive
Orange Park, Florida 32073
Attorney for Personal Representative:
Alison E. Hickman
Attorney for BRADLEY K. IRVINE
Florida Bar Number: 085048
Grady H. Williams, Jr., LL.M.,
Attorneys at Law, P.A.
1543 Kingsley Avenue
Bldg. 5
Orange Park, FL 32073
Telephone: (904) 264-8800
Fax: (904) 264-0155
Primary email address:
alison@floridaelder.com
Secondary email address:
donna@floridaelder.com
July 22, 29, 2016 16-02107P

FIRST INSERTION

NOTICE OF APPLICATION FOR TAX DEED 201600227 (SENATE BILL NO. 163)

NOTICE IS HEREBY GIVEN, that RMC TL 2013 LLC the holder of the following certificate has filed said certificate for a tax deed to be issued thereon. The certificate number and year of issuance, the description of the property, and the names in which it was assessed are as follows:

Certificate No. 1109501
Year of Issuance: June 1, 2012

Description of Property:
09-25-16-0760-00000-1840
PINELAND PARK UNREC PLAT LOT 184 DESC AS COM NE COR OF TRACT 38 PORT RICHEY LAND CO SUB PB 1 PG 61 TH S00DEG21' 13"W 110.00 FT TH N89DEG51' 58"W 493.03 FT FOR POB TH N89DEG51' 58"W 50.00 FT TH S00DEG21'13"W 110.00 FT TH S89DEG51' 58"E 50.00 FT TH N00DEG21'13"E 110.00 FT TO POB SOUTH 25 FT THEREOF SUBJECT TO EASEMENT FOR RD R/W &/OR UTILITIES & NORTH 7.5 FT & EAST 3 FT & WEST 3 FT THEREOF SUBJECT TO EASEMENT FOR DRAINAGE &/OR UTILITIES OR 7865 PG 564

Name (s) in which assessed:
DINO FOTOPULOS

All of said property being in the County of Pasco, State of Florida.

Unless such certificate shall be redeemed according to law the property described in such certificate shall be sold to the highest bidder FOR CASH at the Clerk and Comptrollers Office 38053 Live Oak Ave, 2nd Floor on the 25th day of AUGUST, 2016 at 10:00 AM.

Dated this 11th day of JULY, 2016.
Office of Paula S. O'Neil
CLERK & COMPTROLLER
BY: Susannah Hennessy
Deputy Clerk
July 22, 29; Aug. 5, 12, 2016 16-02056P

FIRST INSERTION

NOTICE TO CREDITORS IN THE CIRCUIT COURT FOR PASCO COUNTY, FLORIDA PROBATE DIVISION File No.

512016CP000601CPAXES
IN RE: ESTATE OF
STEPHEN C. EPPLEY,
Deceased.

The administration of the estate of STEPHEN C. EPPLEY, deceased, whose date of death was January 25, 2016, is pending in the Circuit Court for Pasco County, Florida, Probate Division, the address of which is Paula S. O'Neil, Clerk & Comptroller, Probate Division, 38053 Live Oak Avenue, Dade City, FL 33523-3894. The names and addresses of the Personal Representative and the Personal Representative's attorney are set forth below.

All creditors of the decedent and other persons having claims or demands against decedent's estate on whom a copy of this notice is required to be served must file their claims with this court ON OR BEFORE THE LATER OF 3 MONTHS AFTER THE TIME OF THE FIRST PUBLICATION OF THIS NOTICE OR 30 DAYS AFTER THE DATE OF SERVICE OF A COPY OF THIS NOTICE ON THEM.

All other creditors of the decedent and other persons having claims or demands against decedent's estate must file their claims with this court WITHIN 3 MONTHS AFTER THE DATE OF THE FIRST PUBLICATION OF THIS NOTICE.

ALL CLAIMS NOT FILED WITHIN THE TIME PERIODS SET FORTH IN FLORIDA STATUTES SECTION 733.702 WILL BE FOREVER BARRED.

NOTWITHSTANDING THE TIME PERIODS SET FORTH ABOVE, ANY CLAIM FILED TWO (2) YEARS OR MORE AFTER THE DECEDENT'S DATE OF DEATH IS BARRED.

The date of first publication of this notice is July 22, 2016.

PAULA EPPLEY
Personal Representative
5254 Saddlebrook Way
Wesley Chapel, FL 33543
Attorney for Personal Representative:
DEBRA L. BOJE
Florida Bar Number: 0949604
GUNSTER YOAKLEY &
STEWART, P.A.
401 E. Jackson Street
Suite 2500
Tampa, Florida 33602-5841
Telephone: (813) 222-6614
Fax: (813) 314-6914
E-Mail: dboje@gunster.com
Secondary E-Mail:
jhaner@gunster.com
Secondary E-Mail:
eservice@gunster.com
July 22, 29, 2016 16-02108P

FIRST INSERTION

NOTICE OF APPLICATION FOR TAX DEED 201600223 (SENATE BILL NO. 163)

NOTICE IS HEREBY GIVEN, that RMC TL 2013 LLC the holder of the following certificate has filed said certificate for a tax deed to be issued thereon. The certificate number and year of issuance, the description of the property, and the names in which it was assessed are as follows:

Certificate No. 1108530
Year of Issuance: June 1, 2012

Description of Property:
22-24-16-0090-00000-0781
THE PRESERVE AT SEA PINES (SEA PINES SUBDIVISION UNIT EIGHT) PB 28 PGS 30-33 PORTION OF LOT 78 DESC AS BEGIN AT SE CORNER OF SAID LOT 78 TH N89DG 36' 58"W 29.50 FT TH N00DG 23' 05"E 100.00 FT TH S89DG 36' 55"E 132.60 FT TH S46DG 15' 31"W 143.63 FT TO POB FORMERLY LOT 1 OF SEA PINES UNIT 3 PB 10 PGS 8 & 9 SUBJECT TO LEASE & OPTION AGREEMENT PER OR 1768 PG 1848 OR 5157 PG 1067 OR 8890 PG 3110

Name (s) in which assessed:
JODIE A BIGLER

All of said property being in the County of Pasco, State of Florida.

Unless such certificate shall be redeemed according to law the property described in such certificate shall be sold to the highest bidder FOR CASH at the Clerk and Comptrollers Office 38053 Live Oak Ave, 2nd Floor on the 25th day of AUGUST, 2016 at 10:00 AM.

Dated this 11th day of JULY, 2016.
Office of Paula S. O'Neil
CLERK & COMPTROLLER
BY: Susannah Hennessy
Deputy Clerk
July 22, 29; Aug. 5, 12, 2016 16-02052P

FIRST INSERTION

NOTICE OF APPLICATION FOR TAX DEED 201600219 (SENATE BILL NO. 163)

NOTICE IS HEREBY GIVEN, that RMC TL 2013 LLC the holder of the following certificate has filed said certificate for a tax deed to be issued thereon. The certificate number and year of issuance, the description of the property, and the names in which it was assessed are as follows:

Certificate No. 1107369
Year of Issuance: June 1, 2012

Description of Property:
09-25-17-0080-71600-00B0
BAYWOOD MEADOWS CONDO PHASE 1 OR 1211 PGS 792-988 UNIT B BLDG 7160 & COMMON ELEMENTS OR 6813 PG 558

Name (s) in which assessed:
BAYWOOD MEADOWS CONDOMINIUM
BAYWOOD MEADOWS CONDOMINIUM ASSN INC
DOROTHY KIMBLER
EARL MILLION
IMOLA GYURIS
JESSICA MCCULLY
JIM ZALINKA
LETTITA CAMPBELL
TOM ESCHRICHER

All of said property being in the County of Pasco, State of Florida.

Unless such certificate shall be redeemed according to law the property described in such certificate shall be sold to the highest bidder FOR CASH at the Clerk and Comptrollers Office 38053 Live Oak Ave, 2nd Floor on the 25th day of AUGUST, 2016 at 10:00 AM.

Dated this 11th day of JULY, 2016.
Office of Paula S. O'Neil
CLERK & COMPTROLLER
BY: Susannah Hennessy
Deputy Clerk
July 22, 29; Aug. 5, 12, 2016 16-02048P

HOW TO PUBLISH YOUR LEGAL NOTICE IN THE BUSINESS OBSERVER

CALL 941-906-9386
and select the appropriate County name from the menu option

OR E-MAIL:
legal@businessobserverfl.com

Business Observer

FIRST INSERTION

NOTICE OF APPLICATION
FOR TAX DEED 201600243
(SENATE BILL NO. 163)

NOTICE IS HEREBY GIVEN, that RMC TL 2013 LLC the holder of the following certificate has filed said certificate for a tax deed to be issued thereon. The certificate number and year of issuance, the description of the property, and the names in which it was assessed are as follows:

Certificate No. 1112710
Year of Issuance: June 1, 2012
Description of Property:
20-26-16-0530-00000-1370
COLONIAL MANOR UNIT 8 PB
9 PG 75 LOT 137 OR 8177 PG 1412

Name (s) in which assessed:
DIANE NEUENDORF
All of said property being in the County of Pasco, State of Florida.

Unless such certificate shall be redeemed according to law the property described in such certificate shall be sold to the highest bidder FOR CASH at the Clerk and Comptrollers Office 38053 Live Oak Ave, 2nd Floor on the 25th day of AUGUST, 2016 at 10:00 AM.

Dated this 11th day of JULY, 2016.
Office of Paula S. O'Neil
CLERK & COMPTROLLER
BY: Susannah Hennessy
Deputy Clerk
July 22, 29; Aug. 5, 12, 2016 16-02070P

FIRST INSERTION

NOTICE OF APPLICATION
FOR TAX DEED 201600242
(SENATE BILL NO. 163)

NOTICE IS HEREBY GIVEN, that RMC TL 2013 LLC the holder of the following certificate has filed said certificate for a tax deed to be issued thereon. The certificate number and year of issuance, the description of the property, and the names in which it was assessed are as follows:

Certificate No. 1112644
Year of Issuance: June 1, 2012
Description of Property:
19-26-16-010A-00000-0640
EASTWOOD ACS 2 MB 8 PG 84
L 64

Name (s) in which assessed:
EVELYN JUNE ROCKWELL
All of said property being in the County of Pasco, State of Florida.

Unless such certificate shall be redeemed according to law the property described in such certificate shall be sold to the highest bidder FOR CASH at the Clerk and Comptrollers Office 38053 Live Oak Ave, 2nd Floor on the 25th day of AUGUST, 2016 at 10:00 AM.

Dated this 11th day of JULY, 2016.
Office of Paula S. O'Neil
CLERK & COMPTROLLER
BY: Susannah Hennessy
Deputy Clerk
July 22, 29; Aug. 5, 12, 2016 16-02069P

FIRST INSERTION

NOTICE OF APPLICATION
FOR TAX DEED 201600226
(SENATE BILL NO. 163)

NOTICE IS HEREBY GIVEN, that RMC TL 2013 LLC the holder of the following certificate has filed said certificate for a tax deed to be issued thereon. The certificate number and year of issuance, the description of the property, and the names in which it was assessed are as follows:

Certificate No. 1109374
Year of Issuance: June 1, 2012
Description of Property:
03-25-16-0270-00000-0010
DI PAOLA SUB PB 9 PG 37 LOT 1
OR 7918 PG 398

Name (s) in which assessed:
LARRY G LORENTSEN
All of said property being in the County of Pasco, State of Florida.

Unless such certificate shall be redeemed according to law the property described in such certificate shall be sold to the highest bidder FOR CASH at the Clerk and Comptrollers Office 38053 Live Oak Ave, 2nd Floor on the 25th day of AUGUST, 2016 at 10:00 AM.

Dated this 11th day of JULY, 2016.
Office of Paula S. O'Neil
CLERK & COMPTROLLER
BY: Susannah Hennessy
Deputy Clerk
July 22, 29; Aug. 5, 12, 2016 16-02055P

FIRST INSERTION

NOTICE OF APPLICATION
FOR TAX DEED 201600239
(SENATE BILL NO. 163)

NOTICE IS HEREBY GIVEN, that RMC TL 2013 LLC the holder of the following certificate has filed said certificate for a tax deed to be issued thereon. The certificate number and year of issuance, the description of the property, and the names in which it was assessed are as follows:

Certificate No. 1112254
Year of Issuance: June 1, 2012
Description of Property:
16-26-16-051E-00000-1600
VIRGINIA CITY UNIT 5 PB 17
PGS 104-105 LOT 160 OR 4207
PG 622

Name (s) in which assessed:
LINDA A BAKER
All of said property being in the County of Pasco, State of Florida.

Unless such certificate shall be redeemed according to law the property described in such certificate shall be sold to the highest bidder FOR CASH at the Clerk and Comptrollers Office 38053 Live Oak Ave, 2nd Floor on the 25th day of AUGUST, 2016 at 10:00 AM.

Dated this 11th day of JULY, 2016.
Office of Paula S. O'Neil
CLERK & COMPTROLLER
BY: Susannah Hennessy
Deputy Clerk
July 22, 29; Aug. 5, 12, 2016 16-02067P

FIRST INSERTION

NOTICE OF APPLICATION
FOR TAX DEED 201600237
(SENATE BILL NO. 163)

NOTICE IS HEREBY GIVEN, that RMC TL 2013 LLC the holder of the following certificate has filed said certificate for a tax deed to be issued thereon. The certificate number and year of issuance, the description of the property, and the names in which it was assessed are as follows:

Certificate No. 1110927
Year of Issuance: June 1, 2012
Description of Property:
29-25-16-0060-00000-0080
MARTHA'S VINEYARD UNIT 3
PB 6 PG 108 LOT 8 OR 1074 PG
960

Name (s) in which assessed:
MICHAEL L BARR
All of said property being in the County of Pasco, State of Florida.

Unless such certificate shall be redeemed according to law the property described in such certificate shall be sold to the highest bidder FOR CASH at the Clerk and Comptrollers Office 38053 Live Oak Ave, 2nd Floor on the 25th day of AUGUST, 2016 at 10:00 AM.

Dated this 11th day of JULY, 2016.
Office of Paula S. O'Neil
CLERK & COMPTROLLER
BY: Susannah Hennessy
Deputy Clerk
July 22, 29; Aug. 5, 12, 2016 16-02065P

FIRST INSERTION

NOTICE OF APPLICATION
FOR TAX DEED 201600221
(SENATE BILL NO. 163)

NOTICE IS HEREBY GIVEN, that RMC TL 2013 LLC the holder of the following certificate has filed said certificate for a tax deed to be issued thereon. The certificate number and year of issuance, the description of the property, and the names in which it was assessed are as follows:

Certificate No. 1107804
Year of Issuance: June 1, 2012
Description of Property:
21-25-17-0120-20600-0350
MOON LAKE ESTATES UNIT 12
PB 5 PGS 151-153 LOTS 35 & 36
BLOCK 206 OR 8368 PG 1271

Name (s) in which assessed:
ALLEN HOWARD
All of said property being in the County of Pasco, State of Florida.

Unless such certificate shall be redeemed according to law the property described in such certificate shall be sold to the highest bidder FOR CASH at the Clerk and Comptrollers Office 38053 Live Oak Ave, 2nd Floor on the 25th day of AUGUST, 2016 at 10:00 AM.

Dated this 11th day of JULY, 2016.
Office of Paula S. O'Neil
CLERK & COMPTROLLER
BY: Susannah Hennessy
Deputy Clerk
July 22, 29; Aug. 5, 12, 2016 16-02050P

FIRST INSERTION

NOTICE OF APPLICATION
FOR TAX DEED 201600234
(SENATE BILL NO. 163)

NOTICE IS HEREBY GIVEN, that RMC TL 2013 LLC the holder of the following certificate has filed said certificate for a tax deed to be issued thereon. The certificate number and year of issuance, the description of the property, and the names in which it was assessed are as follows:

Certificate No. 1110545
Year of Issuance: June 1, 2012
Description of Property:
23-25-16-0090-00000-8020
THE LAKES UNIT 4 PB 18 PGS
40-41 LOT 802 OR 6345 PG 314
& OR 7629 PG 531

Name (s) in which assessed:
ESTATE OF DONNA BELENSKI
All of said property being in the County of Pasco, State of Florida.

Unless such certificate shall be redeemed according to law the property described in such certificate shall be sold to the highest bidder FOR CASH at the Clerk and Comptrollers Office 38053 Live Oak Ave, 2nd Floor on the 25th day of AUGUST, 2016 at 10:00 AM.

Dated this 11th day of JULY, 2016.
Office of Paula S. O'Neil
CLERK & COMPTROLLER
BY: Susannah Hennessy
Deputy Clerk
July 22, 29; Aug. 5, 12, 2016 16-02062P

FIRST INSERTION

NOTICE OF APPLICATION
FOR TAX DEED 201600233
(SENATE BILL NO. 163)

NOTICE IS HEREBY GIVEN, that RMC TL 2013 LLC the holder of the following certificate has filed said certificate for a tax deed to be issued thereon. The certificate number and year of issuance, the description of the property, and the names in which it was assessed are as follows:

Certificate No. 1110385
Year of Issuance: June 1, 2012
Description of Property:
22-25-16-076H-00001-4920
REGENCY PARK UNIT 9 PB 15
PGS 11 & 12 LOT 1492 OR 6060
PG 222

Name (s) in which assessed:
KENNETH RICHARD
All of said property being in the County of Pasco, State of Florida.

Unless such certificate shall be redeemed according to law the property described in such certificate shall be sold to the highest bidder FOR CASH at the Clerk and Comptrollers Office 38053 Live Oak Ave, 2nd Floor on the 25th day of AUGUST, 2016 at 10:00 AM.

Dated this 11th day of JULY, 2016.
Office of Paula S. O'Neil
CLERK & COMPTROLLER
BY: Susannah Hennessy
Deputy Clerk
July 22, 29; Aug. 5, 12, 2016 16-02061P

FIRST INSERTION

NOTICE OF APPLICATION
FOR TAX DEED 201600232
(SENATE BILL NO. 163)

NOTICE IS HEREBY GIVEN, that RMC TL 2013 LLC the holder of the following certificate has filed said certificate for a tax deed to be issued thereon. The certificate number and year of issuance, the description of the property, and the names in which it was assessed are as follows:

Certificate No. 1110071
Year of Issuance: June 1, 2012
Description of Property:
15-25-16-0320-00000-1280
PALM TERRACE ESTATES
UNIT 5 PB 9 PG 127 LOT 128 OR
3655 PG 1235

Name (s) in which assessed:
CONNIE BISCUP DECEASED
All of said property being in the County of Pasco, State of Florida.

Unless such certificate shall be redeemed according to law the property described in such certificate shall be sold to the highest bidder FOR CASH at the Clerk and Comptrollers Office 38053 Live Oak Ave, 2nd Floor on the 25th day of AUGUST, 2016 at 10:00 AM.

Dated this 11th day of JULY, 2016.
Office of Paula S. O'Neil
CLERK & COMPTROLLER
BY: Susannah Hennessy
Deputy Clerk
July 22, 29; Aug. 5, 12, 2016 16-02060P

FIRST INSERTION

NOTICE OF APPLICATION
FOR TAX DEED 201600222
(SENATE BILL NO. 163)

NOTICE IS HEREBY GIVEN, that RMC TL 2013 LLC the holder of the following certificate has filed said certificate for a tax deed to be issued thereon. The certificate number and year of issuance, the description of the property, and the names in which it was assessed are as follows:

Certificate No. 1108494
Year of Issuance: June 1, 2012
Description of Property:
22-24-16-0020-00B00-0271
GULF SIDE ESTATES PB 6 PGS
63-63A LOT 27 BLOCK B OR
6690 PG 1097

Name (s) in which assessed:
NANCY UNDERHILL
All of said property being in the County of Pasco, State of Florida.

Unless such certificate shall be redeemed according to law the property described in such certificate shall be sold to the highest bidder FOR CASH at the Clerk and Comptrollers Office 38053 Live Oak Ave, 2nd Floor on the 25th day of AUGUST, 2016 at 10:00 AM.

Dated this 11th day of JULY, 2016.
Office of Paula S. O'Neil
CLERK & COMPTROLLER
BY: Susannah Hennessy
Deputy Clerk
July 22, 29; Aug. 5, 12, 2016 16-02051P

FIRST INSERTION

NOTICE OF APPLICATION
FOR TAX DEED 201600245
(SENATE BILL NO. 163)

NOTICE IS HEREBY GIVEN, that RMC TL 2013 LLC the holder of the following certificate has filed said certificate for a tax deed to be issued thereon. The certificate number and year of issuance, the description of the property, and the names in which it was assessed are as follows:

Certificate No. 1113320
Year of Issuance: June 1, 2012
Description of Property:
31-26-16-021A-00000-4400
CREST RIDGE GARDENS UNIT
5 PB 8 PG 85 LOT 440 OR 3841
PG 1261

Name (s) in which assessed:
BESSIE KOSTOGIANNES
DECEASED
All of said property being in the County of Pasco, State of Florida.

Unless such certificate shall be redeemed according to law the property described in such certificate shall be sold to the highest bidder FOR CASH at the Clerk and Comptrollers Office 38053 Live Oak Ave, 2nd Floor on the 25th day of AUGUST, 2016 at 10:00 AM.

Dated this 11th day of JULY, 2016.
Office of Paula S. O'Neil
CLERK & COMPTROLLER
BY: Susannah Hennessy
Deputy Clerk
July 22, 29; Aug. 5, 12, 2016 16-02072P

FIRST INSERTION

NOTICE OF APPLICATION
FOR TAX DEED 201600240
(SENATE BILL NO. 163)

NOTICE IS HEREBY GIVEN, that RMC TL 2013 LLC the holder of the following certificate has filed said certificate for a tax deed to be issued thereon. The certificate number and year of issuance, the description of the property, and the names in which it was assessed are as follows:

Certificate No. 1112509
Year of Issuance: June 1, 2012
Description of Property:
18-26-16-0130-00000-0500
MELODIE HILLS UNIT 2 PB
8 PG 140 LOT 50 OR 6403 PG
2000

Name (s) in which assessed:
DANA IANNUZZI
DANIEL ROBERT
All of said property being in the County of Pasco, State of Florida.

Unless such certificate shall be redeemed according to law the property described in such certificate shall be sold to the highest bidder FOR CASH at the Clerk and Comptrollers Office 38053 Live Oak Ave, 2nd Floor on the 25th day of AUGUST, 2016 at 10:00 AM.

Dated this 11th day of JULY, 2016.
Office of Paula S. O'Neil
CLERK & COMPTROLLER
BY: Susannah Hennessy
Deputy Clerk
July 22, 29; Aug. 5, 12, 2016 16-02068P

FIRST INSERTION

NOTICE OF APPLICATION
FOR TAX DEED 201600220
(SENATE BILL NO. 163)

NOTICE IS HEREBY GIVEN, that RMC TL 2013 LLC the holder of the following certificate has filed said certificate for a tax deed to be issued thereon. The certificate number and year of issuance, the description of the property, and the names in which it was assessed are as follows:

Certificate No. 1110742
Year of Issuance: June 1, 2012
Description of Property:
15-25-17-0060-07400-0010
BLK 74 MOON LAKE NO 6 PB 4
PGS 90, 91 LOTS 1 TO 10 INCL.
OR 6274 PG 155

Name (s) in which assessed:
SHELLY LINDELL
STEVEN M DUBOIS
All of said property being in the County of Pasco, State of Florida.

Unless such certificate shall be redeemed according to law the property described in such certificate shall be sold to the highest bidder FOR CASH at the Clerk and Comptrollers Office 38053 Live Oak Ave, 2nd Floor on the 25th day of AUGUST, 2016 at 10:00 AM.

Dated this 11th day of JULY, 2016.
Office of Paula S. O'Neil
CLERK & COMPTROLLER
BY: Susannah Hennessy
Deputy Clerk
July 22, 29; Aug. 5, 12, 2016 16-02049P

FIRST INSERTION

NOTICE OF APPLICATION
FOR TAX DEED 201600238
(SENATE BILL NO. 163)

NOTICE IS HEREBY GIVEN, that RMC TL 2013 LLC the holder of the following certificate has filed said certificate for a tax deed to be issued thereon. The certificate number and year of issuance, the description of the property, and the names in which it was assessed are as follows:

Certificate No. 1111071
Year of Issuance: June 1, 2012
Description of Property:
32-25-16-0080-00000-0120
COTEE RIVER TRAILER ES-
TATES PB 7 PG 144 LOTS 12, 13
& SLY 20 FT OF LOT 11 OR 8374
PG 365

Name (s) in which assessed:
CECIL ROY SR
RUBY DELAIN HUNTER
All of said property being in the County of Pasco, State of Florida.

Unless such certificate shall be redeemed according to law the property described in such certificate shall be sold to the highest bidder FOR CASH at the Clerk and Comptrollers Office 38053 Live Oak Ave, 2nd Floor on the 25th day of AUGUST, 2016 at 10:00 AM.

Dated this 11th day of JULY, 2016.
Office of Paula S. O'Neil
CLERK & COMPTROLLER
BY: Susannah Hennessy
Deputy Clerk
July 22, 29; Aug. 5, 12, 2016 16-02066P

FIRST INSERTION

NOTICE OF APPLICATION
FOR TAX DEED 201600230
(SENATE BILL NO. 163)

NOTICE IS HEREBY GIVEN, that RMC TL 2013 LLC the holder of the following certificate has filed said certificate for a tax deed to be issued thereon. The certificate number and year of issuance, the description of the property, and the names in which it was assessed are as follows:

Certificate No. 1109831
Year of Issuance: June 1, 2012
Description of Property:
12-25-16-0090-05600-0030
GRIFFIN PARK PB 2 PGS 78-78A
LOT 3 BLOCK 56 OR 6145 PG
333

Name (s) in which assessed:
JUANITA R MOSNY
SUNTINO L MOSNY
SUNTINO MOSNY
All of said property being in the County of Pasco, State of Florida.

Unless such certificate shall be redeemed according to law the property described in such certificate shall be sold to the highest bidder FOR CASH at the Clerk and Comptrollers Office 38053 Live Oak Ave, 2nd Floor on the 25th day of AUGUST, 2016 at 10:00 AM.

Dated this 11th day of JULY, 2016.
Office of Paula S. O'Neil
CLERK & COMPTROLLER
BY: Susannah Hennessy
Deputy Clerk
July 22, 29; Aug. 5, 12, 2016 16-02059P

FIRST INSERTION

NOTICE OF APPLICATION
FOR TAX DEED 201600235
(SENATE BILL NO. 163)

NOTICE IS HEREBY GIVEN, that RMC TL 2013 LLC the holder of the following certificate has filed said certificate for a tax deed to be issued thereon. The certificate number and year of issuance, the description of the property, and the names in which it was assessed are as follows:

Certificate No. 1110692
Year of Issuance: June 1, 2012
Description of Property:
27-25-16-0010-03100-0011
PORT RICHEY COMPANY SUB
PB 1 PG 61 N 68 FT OF S 200.00
FT OF W 130.00 FT OF TR 31 OR
3584 PG 949

Name (s) in which assessed:
ATUL V PATEL
RAJEN V PATEL
U AND V INVESTMENTS INC
All of said property being in the County of Pasco, State of Florida.

Unless such certificate shall be redeemed according to law the property described in such certificate shall be sold to the highest bidder FOR CASH at the Clerk and Comptrollers Office 38053 Live Oak Ave, 2nd Floor on the 25th day of AUGUST, 2016 at 10:00 AM.

Dated this 11th day of JULY, 2016.
Office of Paula S. O'Neil
CLERK & COMPTROLLER
BY: Susannah Hennessy
Deputy Clerk
July 22, 29; Aug. 5, 12, 2016 16-02063P

FIRST INSERTION

NOTICE OF APPLICATION
FOR TAX DEED 201600229
(SENATE BILL NO. 163)

NOTICE IS HEREBY GIVEN, that RMC TL 2013 LLC the holder of the following certificate has filed said certificate for a tax deed to be issued thereon. The certificate number and year of issuance, the description of the property, and the names in which it was assessed are as follows:

Certificate No. 1109652
Year of Issuance: June 1, 2012
Description of Property:
10-25-16-055A-00000-0100
GULF HIGHLANDS UNIT 1 PB
10 PGS 116-118 LOT 10 OR 8981
PG 3425

Name (s) in which assessed:
BAY2BAY AREA HOLDING
GROUP LLC
DAVID GRIFFIN
SPIEGEL & UTRERA PA
All of said property being in the County of Pasco, State of Florida.

Unless such certificate shall be redeemed according to law the property described in such certificate shall be sold to the highest bidder FOR CASH at the Clerk and Comptrollers Office 38053 Live Oak Ave, 2nd Floor on the 25th day of AUGUST, 2016 at 10:00 AM.

Dated this 11th day of JULY, 2016.
Office of Paula S. O'Neil
CLERK & COMPTROLLER
BY: Susannah Hennessy
Deputy Clerk
July 22, 29; Aug. 5, 12, 2016 16-02058P

FIRST INSERTION

NOTICE OF APPLICATION
FOR TAX DEED 201600244
(SENATE BILL NO. 163)

NOTICE IS HEREBY GIVEN, that RMC TL 2013 LLC the holder of the following certificate has filed said certificate for a tax deed to be issued thereon. The certificate number and year of issuance, the description of the property, and the names in which it was assessed are as follows:

Certificate No. 1113157
Year of Issuance: June 1, 2012
Description of Property:
30-26-16-0130-00000-863G
RIDGWOOD GARDENS 1ST
ADDITION PB 7 PG 132 LOT
863-G OR 3698 PG 1216 & OR
6260 PG 1052 OR 8861 PG 2592

Name (s) in which assessed:
JOEL C ALDAY
LUKE J ALDAY
VERN CULM
ROSS CULM
All of said property being in the County of Pasco, State of Florida.

Unless such certificate shall be redeemed according to law the property described in such certificate shall be sold to the highest bidder FOR CASH at the Clerk and Comptrollers Office 38053 Live Oak Ave, 2nd Floor on the 25th day of AUGUST, 2016 at 10:00 AM.

Dated this 11th day of JULY, 2016.
Office of Paula S. O'Neil
CLERK & COMPTROLLER
BY: Susannah Hennessy
Deputy Clerk
July 22, 29; Aug. 5, 12, 2016 16-02071P



SAVE TIME - EMAIL YOUR LEGAL NOTICES

Sarasota County • Manatee County • Hillsborough County • Charlotte County • Pinellas County • Pasco County • Polk County • Lee County • Collier County • Orange County

legal@businessobserverfl.com



Wednesday 2pm Deadline for Friday Publication | Wednesday 10am for Thursday Publication in Orange County

FIRST INSERTION

NOTICE TO CREDITORS IN THE CIRCUIT COURT FOR PASCO COUNTY, FLORIDA PROBATE DIVISION
File No. 51-2016-CP-000795-WS
IN RE: ESTATE OF LOUISE E. YACEK Deceased.

The administration of the estate of LOUISE E. YACEK, deceased, whose date of death was June 8, 2016, is pending in the Circuit Court for Pasco County, Florida, Probate Division, the address of which is P. O. Drawer 338, New Port Richey, FL 34656-0338. The names and addresses of the personal representative and the personal representative's attorney are set forth below.

All creditors of the decedent and other persons having claims or demands against decedent's estate on whom a copy of this notice is required to be served must file their claims with this court ON OR BEFORE THE LATER OF 3 MONTHS AFTER THE TIME OF THE FIRST PUBLICATION OF THIS NOTICE OR 30 DAYS AFTER THE DATE OF SERVICE OF A COPY OF THIS NOTICE ON THEM.

All other creditors of the decedent and other persons having claims or demands against decedent's estate must file their claims with this court WITHIN 3 MONTHS AFTER THE DATE OF THE FIRST PUBLICATION OF THIS NOTICE.

ALL CLAIMS NOT FILED WITHIN THE TIME PERIODS SET FORTH IN FLORIDA STATUTES SECTION 733.702 WILL BE FOREVER BARRED.

NOTWITHSTANDING THE TIME PERIODS SET FORTH ABOVE, ANY CLAIM FILED TWO (2) YEARS OR MORE AFTER THE DECEDENT'S DATE OF DEATH IS BARRED.

The date of first publication of this notice is July 22, 2016.

Personal Representative:
RAFFAELA LENA TESTO
 10015 Trinity Blvd., Suite 101
 Trinity, FL 34655

Attorney for Personal Representative:
 DAVID J. WOLLINKA
 Attorney
 Florida Bar Number: 608483
 WOLLINKA, WOLLINKA & DODDRIDGE
 10015 TRINITY BLVD
 SUITE 101
 TRINITY, FL 34655
 Telephone: (727) 937-4177
 Fax: (727) 478-7007
 E-Mail: pleadings@wollinka.com
 Secondary E-Mail:
 jamie@wollinka.com
 July 22, 29, 2016 16-02132P

FIRST INSERTION

NOTICE OF ACTION IN THE CIRCUIT COURT OF THE SIXTH JUDICIAL CIRCUIT IN AND FOR PASCO COUNTY, FLORIDA
CASE NO. 2016CA001323CAAXWS
WELLS FARGO BANK, N.A.
Plaintiff, v.
LORETTA R CORMIER, ET AL.
Defendants.

TO: SUZANNE SNYDER-DAUGHENBAUGH, and all unknown parties claiming by, through, under or against the above named Defendant(s), who (is/are) not known to be dead or alive, whether said unknown parties claim as heirs, devisees, grantees, assignees, lienors, creditors, trustees, spouses, or other claimants

Current Residence Unknown, but whose last known address was:
 7130 INGLESIDE DR
 PORT RICHEY, FL 34668

YOU ARE NOTIFIED that an action to foreclose a mortgage on the following property in Pasco County, Florida, to-wit:

LOT 1940, REGENCY PARK, UNIT 12, ACCORDING TO THE PLAT THEREOF AS RECORDED IN PLAT BOOK 16, PAGES 7-9, OF THE PUBLIC RECORDS OF PASCO COUNTY, FLORIDA.

has been filed against you and you are required to serve a copy of your written defenses, if any, to it on EXL LEGAL, PLLC, Plaintiff's attorney, whose address is 12425 28th Street North, Suite 200, St. Petersburg, FL 33716, on or before 8/22/16 or within thirty (30) days after the first publication of this Notice of Action, and file the original with the Clerk of this Court at West Pasco County Judicial Center, 7530 Little Road, New Port Richey, FL 34654, either before service on Plaintiff's attorney or immediately thereafter; otherwise, a default will be entered against you for the relief demanded in the complaint petition.

ANY PERSONS WITH A DISABILITY REQUIRING REASONABLE ACCOMMODATIONS SHOULD CALL NEW PORT RICHEY (813) 847-8110; DADE CITY (352) 521-4274 EXT 8110; TDD 1-800-955-8771 VIA FLORIDA RELAY SERVICE, NO LATER THAN SEVEN (7) DAYS PRIOR TO ANY PROCEEDING.

WITNESS my hand and seal of the Court on this 12 day of July, 2016.

Paula S. O'Neil, Ph.D.,
 Clerk & Comptroller
 (SEAL) By: Carmella Hernandez
 Deputy Clerk

EXL LEGAL, PLLC,
 Plaintiff's attorney
 12425 28th Street North, Suite 200
 St. Petersburg, FL 33716
 888160250
 July 22, 29, 2016 16-02120P

FIRST INSERTION

NOTICE TO CREDITORS IN THE CIRCUIT COURT FOR PASCO COUNTY, FLORIDA PROBATE DIVISION
File No. 2016CP000549CPAXWS
IN RE: ESTATE OF JOAN WERSEL, (a/k/a JOAN H. WERSEL) Deceased.

The administration of the estate of JOAN WERSEL, also known as JOAN H. WERSEL, deceased, whose date of death was November 1, 2015, is pending in the Circuit Court for Pasco County, Florida, Probate Division, the address of which is 7530 Little Road, Suite 104, New Port Richey, FL 34654. The names and addresses of the personal representative and the personal representative's attorney are set forth below.

All creditors of the decedent and other persons having claims or demands against decedent's estate, on whom a copy of this notice is required to be served, must file their claims with this court ON OR BEFORE THE LATER OF 3 MONTHS AFTER THE TIME OF THE FIRST PUBLICATION OF THIS NOTICE OR 30 DAYS AFTER THE DATE OF SERVICE OF A COPY OF THIS NOTICE ON THEM.

All other creditors of the decedent and other persons having claims or demands against decedent's estate must file their claims with this court WITHIN 3 MONTHS AFTER THE DATE OF THE FIRST PUBLICATION OF THIS NOTICE.

ALL CLAIMS NOT FILED WITHIN THE TIME PERIODS SET FORTH IN FLORIDA STATUTES SECTION 733.702 WILL BE FOREVER BARRED.

NOTWITHSTANDING THE TIME PERIOD SET FORTH ABOVE, ANY CLAIM FILED TWO (2) YEARS OR MORE AFTER THE DECEDENT'S DATE OF DEATH IS BARRED.

The date of first publication of this notice is July 22, 2016.

WILLIAM WERSEL, JR.
Personal Representative
 7291 Columbia Road
 Maineville, OH 45039

JORDAN G. LEE
 Attorney for Personal Representative
 Florida Bar No. 10209
 Shutts & Bowen LLP
 4301 W. Boy Scout Blvd., Suite 300
 Tampa, FL 33607
 Telephone: (813) 227-8183
 Email: jlee@shutts.com
 Secondary Email:
 cziegenfuss@shutts.com
 July 22, 29, 2016 16-02126P

FIRST INSERTION

NOTICE OF FORECLOSURE SALE IN THE CIRCUIT COURT OF THE SIXTH JUDICIAL CIRCUIT IN AND FOR PASCO COUNTY, FLORIDA
CASE NO.: 2014-CA-004221-WS
DEUTSCHE BANK NATIONAL TRUST COMPANY, AS INDENTURE TRUSTEE FOR AMERICAN HOME MORTGAGE INVESTMENT TRUST 2007-1,
Plaintiff, -vs.-
TROY MILLARD A/K/A TROY A. MILLARD, et al,
Defendant(s).

NOTICE IS HEREBY GIVEN pursuant to the Order Canceling and Rescheduling Foreclosure Sale dated June 22, 2016 in the above action. Paula S. O'Neil, the Pasco County Clerk of Court will sell to the highest bidder for cash at Pasco, Florida, on September 21, 2016, at 10:00 a.m., at www.pasco.realforeclose.com for the following described property:

LOT 8, WESLEY POINTE PHASE 1, ACCORDING TO MAP OR PLAT THEREOF AS RECORDED IN PLAT BOOK 34, PAGE 16 OF THE PUBLIC RECORDS OF PASCO COUNTY, FLORIDA
 PROPERTY ADDRESS: 6051 Sand Key Lane, Wesley Chapel, FL 33544.

Any person claiming an interest in the surplus from the sale, if any, other than the property owner as of the date of the lis pendens must file a claim within sixty (60) days after the sale. The Court, in its discretion, may enlarge the time of the sale. Notice of the changed time of sale shall be published as provided herein.

If you are a person with a disability who needs any accommodation in order to participate in this proceeding, you are entitled, at no cost to you, to the provision of certain assistance. Please contact the Public Information Department at 727-847-8110 (V) in New Port Richey or 352-521-4274, extension 8110 (V) in Dade City or at Pasco County Government Center, 7530 Little Road, New Port Richey, FL 34654 at least 7 days before your scheduled court appearance, or immediately upon receiving this notification if the time before the scheduled appearance is less than 7 days; if you are hearing or voice impaired, call 711. The court does not provide transportation and cannot accommodate such requests. Persons with disabilities needing transportation to court should contact their local public transportation providers for information regarding transportation services.

Galina Boytchev, Esq.
 FBN: 47008

Ward, Damon, Posner,
 Pheterson & Bleau PL
 Attorney for Plaintiff
 4420 Beacon Circle
 West Palm Beach, FL 33407
 Tel: (561) 842-3000
 Fax: (561) 842-3626
 Email:
 foreclosure@warddameron.com
 July 22, 29, 2016 16-02123P

FIRST INSERTION

NOTICE OF FORECLOSURE SALE IN THE CIRCUIT COURT OF THE SIXTH JUDICIAL CIRCUIT IN AND FOR PASCO COUNTY, FLORIDA
GENERAL JURISDICTION DIVISION
Case No.
2013-CA-001456-ES
PENNYMAC CORP.,
Plaintiff, vs.
David Gobel; and Shannon Gobel, Husband and Wife; Unknown Parties in Possession #1; If living, and all Unknown Parties claiming by, through, under and against the above named Defendant(s) who are not known to be dead or alive, whether said Unknown Parties may claim an interest as Spouse, Heirs, Devisees, Grantees, or Other Claimants; and Unknown Parties in Possession #2; If living, and all Unknown Parties claiming by, through, under and against the above named Defendant(s) who are not known to be dead or alive, whether said Unknown Parties may claim an interest as Spouse, Heirs, Devisees, Grantees, or Other Claimants, Defendants.

NOTICE IS HEREBY GIVEN pursuant to a Final Judgment of Foreclosure dated July 1, 2016, entered in Case No. 2013-CA-001456-ES of the Circuit Court of the Sixth Judicial Circuit, in and for Pasco County, Florida, wherein PENNYMAC CORP. is the Plaintiff and David Gobel; and Shannon Gobel, Husband and Wife; Unknown Parties in Possession #1; If living, and all Unknown Parties claiming by, through, under and against the above named Defendant(s) who are not known to be dead or alive, whether said Unknown Parties may claim an interest as Spouse, Heirs, Devisees, Grantees, or Other Claimants; Unknown Parties in Possession #2; If living, and all Unknown Parties claiming by, through, under and against the above named Defendant(s) who are not known to be dead or alive, whether said Unknown Parties may claim an interest as Spouse, Heirs, Devisees, Grantees, or Other Claimants; are the Defendants, that Paula O'Neil, Pasco County Clerk of Court will sell to the highest and

FIRST INSERTION

NOTICE OF SALE UNDER F.S. CHAPTER 45 IN THE CIRCUIT COURT OF THE SIXTH JUDICIAL CIRCUIT IN AND FOR PASCO COUNTY, FLORIDA
CASE NO.: 2013-CA-00333ES
DEUTSCHE BANK NATIONAL TRUST COMPANY, AS TRUSTEE FOR MORGAN STANLEY ABS CAPITAL I INC. TRUST 2005-HE7, MORTGAGE PASS-THROUGH CERTIFICATES, SERIES 2005-HE7,
Plaintiff v.
WILLIAM RICHARD VARGAS A/K/A WILLIAM VARGAS; ET. AL.,
Defendant(s).

NOTICE IS GIVEN that, in accordance with the Uniform Final Judgment of Foreclosure dated June 22, 2016, in the above-styled cause, the Clerk of Circuit Court, Paula S. O'Neil, shall sell the subject property at public sale on the 17th day of August, 2016, at 11:00 a.m., to the highest and best bidder for cash, at www.pasco.realforeclose.com for the following described property:

LOT 1, BLOCK 4, MEADOW POINTE PARCEL 8, UNIT 6, ACCORDING TO THE MAP OR PLAT THEREOF, AS RECORDED IN PLAT BOOK 34, PAGES 94-96, PUBLIC RECORDS OF PASCO COUNTY, FLORIDA.
 Property Address: 29430 TANSY PASS, WESLEY CHAPEL, FLORIDA 33543.

Any person claiming an interest in the surplus from the sale, if any, other than the property owner as of the date of the lis pendens must file a claim within 60 days after the sale.

If you are a person with a disability who needs any accommodation in order to participate in this proceeding, you are entitled, at no cost to you, to the provision of certain assistance. Please contact the Public Information Dept., Pasco County Government Center, 7530 Little Rd., New Port Richey, FL 34654; (727) 847-8110 (V) in New Port Richey; (352) 521-4274, ext 8110 (V) in Dade City, at least 7 days before your scheduled court appearance, or immediately upon receiving this notification if the time before the scheduled appearance is less than 7 days; if you are hearing impaired call 711. The court does not provide transportation and cannot accommodate for this service. Persons with disabilities needing transportation to court should contact their local public transportation providers for information regarding transportation services.

Dated: July 15, 2016.
 John J. Schreiber, Esquire
 Florida Bar No.: 62249
 jschreiber@pearsonbitman.com

PEARSON BITMAN LLP
 485 N. Keller Rd, Suite 401
 Maitland, Florida 32751
 Telephone: (407) 647-0090
 Facsimile: (407) 647-0092
 Attorney for Plaintiff
 July 22, 29, 2016 16-02088P

FIRST INSERTION

best bidder for cash by electronic sale at www.pasco.realforeclose.com, beginning at 11:00 AM on the 4th day of August, 2016, the following described property as set forth in said Final Judgment, to wit:

LOTS 4 THROUGH 12, INCLUSIVE, AND THE SOUTH HALF OF FORMER HENLEY STREET, ADJOINING SAID LOTS, IN BRANNON PLACE, ACCORDING TO THE PLAT THEREOF, AS RECORDED IN PLAT BOOK 2, PAGE 55, OF THE PUBLIC RECORDS OF PASCO COUNTY, FLORIDA.

Any person claiming an interest in the surplus from the sale, if any, other than the property owner as of the date of the lis pendens must file a claim within 60 days after the sale.

If you are a person with a disability who needs any accommodation in order to participate in this proceeding, you are entitled, at no cost to you, to the provision of certain assistance. Please contact the Public Information Dept., Pasco County Government Center, 7530 Little Rd., New Port Richey, FL 34654; (727) 847-8110 (V) in New Port Richey; (352) 521-4274, ext 8110 (V) in Dade City, at least 7 days before your scheduled court appearance, or immediately upon receiving this notification if the time before the scheduled appearance is less than 7 days; if you are hearing impaired call 711. The court does not provide transportation and cannot accommodate for this service. Persons with disabilities needing transportation to court should contact their local public transportation providers for information regarding transportation services.

Dated this 19 day of July, 2016.
 By Kathleen McCarthy, Esq.
 Florida Bar No. 72161

BROCK & SCOTT, PLLC
 Attorney for Plaintiff
 1501 N.W. 49th Street,
 Suite 200
 Ft. Lauderdale, FL 33309
 Phone: (954) 618-6955,
 ext. 6177
 Fax: (954) 618-6954
 FLCourtDocs@brockandscott.com
 File # 15-F04840
 July 22, 29, 2016 16-02131P

FIRST INSERTION

NOTICE OF FORECLOSURE SALE IN THE CIRCUIT COURT OF THE SIXTH JUDICIAL CIRCUIT IN AND FOR PASCO COUNTY, FLORIDA
GENERAL JURISDICTION DIVISION
Case No. 2015CA000713CAAXWS
Oewen Loan Servicing, LLC,
Plaintiff, vs.
Thomas F. Sullivan; Laura L. Sullivan,
Defendants.

NOTICE IS HEREBY GIVEN pursuant to a Final Judgment of Foreclosure dated June 30, 2016, entered in Case No. 2015CA000713CAAXWS of the Circuit Court of the Sixth Judicial Circuit, in and for Pasco County, Florida, wherein Oewen Loan Servicing, LLC is the Plaintiff and Thomas F. Sullivan; Laura L. Sullivan are the Defendants, that Paula O'Neil, Pasco County Clerk of Court will sell to the highest and best bidder for cash by electronic sale at www.pasco.realforeclose.com, beginning at 11:00 AM on the 18th day of August, 2016, the following described property as set forth in said Final Judgment, to wit:

LOT 24, BLOCK 1 OF FLORIDA-MAR SECTION 16-B, ACCORDING TO THE MAP OR PLAT THEREOF AS RECORDED IN PLAT BOOK 9, PAGE(S) 110, OF THE PUBLIC RECORDS OF PASCO COUNTY, FLORIDA.

Any person claiming an interest in the surplus from the sale, if any, other than the property owner as of the date of the lis pendens must file a claim within 60 days after the sale.

If you are a person with a disability who needs any accommodation in order to participate in this proceeding, you are entitled, at no cost to you, to the provision of certain assistance. Please contact the Public Information Dept., Pasco County Government Center, 7530 Little Rd., New Port Richey, FL 34654; (727) 847-8110 (V) in New Port Richey; (352) 521-4274, ext 8110 (V) in Dade City, at least 7 days before your scheduled court appearance, or immediately upon receiving this notification if the time before the scheduled appearance is less than 7 days; if you are hearing impaired call 711.

If you are a person with a disability who needs any accommodation in order to participate in this proceeding, you are entitled, at no cost to you, to the provision of certain assistance. Please contact the Public Information Dept., Pasco County Government Center, 7530 Little Rd., New Port Richey, FL 34654; (727) 847-8110 (V) for proceedings in New Port Richey; (352) 521-4274, ext. 8110 (V) for proceedings in Dade City at least 7 days before your scheduled court appearance, or immediately upon receiving this notification if the time before the scheduled appearance is less than seven (7) days; if you are hearing or voice impaired, call 711.

Dated this 13 day of July, 2016
 Eric M. Knopp, Esq.
 Bar No.: 709921

Submitted by:
 Kahane & Associates, P.A.
 8201 Peters Road, Ste.3000
 Plantation, FL 33324
 Telephone: (954) 382-3486
 Telefacsimile: (954) 382-5380
 Designated service email:
 notice@kahaneandassociates.com
 File No.: 12-06125 SF
 July 22, 29, 2016 16-02075P

FIRST INSERTION

NOTICE OF FORECLOSURE SALE IN THE CIRCUIT COURT OF THE SIXTH JUDICIAL CIRCUIT IN AND FOR PASCO COUNTY, FLORIDA
CASE NO.:
51-2014-CA-001724-CAAX-WS
THE BANK OF NEW YORK MELLON, AS TRUSTEE FOR CIT MORTGAGE LOAN TRUST 2007-1,
Plaintiff, vs.
STEPHEN J. GARDNER; ANGELLA M. GARDNER; IF LIVING, ANY AND ALL UNKNOWN PARTIES CLAIMING BY, THROUGH, UNDER AND AGAINST THE ABOVE NAMED DEFENDANT(S) WHO ARE NOT KNOWN TO BE DEAD OR ALIVE, WHETHER SAID UNKNOWN PARTIES MAY CLAIM AN INTEREST AS SPOUSE, HEIRS, DEVISEES, GRANTEEES, OR OTHER CLAIMANTS; CYPRESS LAKE HOMEOWNERS ASSOCIATION OF PASCO, INC.; UNKNOWN PARTIES IN POSSESSION #1; UNKNOWN PARTIES IN POSSESSION #2,
Defendant(s).

NOTICE IS HEREBY GIVEN pursuant to a Uniform Final Judgment of Foreclosure dated July 7, 2016, entered in Civil Case No.: 51-2014-CA-001724-CAAX-WS of the Circuit Court of the Sixth Judicial Circuit in and for Pasco County, Florida, wherein THE BANK OF NEW YORK MELLON, AS TRUSTEE FOR CIT MORTGAGE LOAN TRUST 2007-1, Plaintiff, and STEPHEN J. GARDNER; ANGELLA M. GARDNER; IF LIVING, ANY AND ALL UNKNOWN PARTIES CLAIMING BY, THROUGH, UNDER AND AGAINST THE ABOVE NAMED DEFENDANT(S) WHO ARE NOT KNOWN TO BE DEAD OR ALIVE, WHETHER SAID UNKNOWN PARTIES MAY CLAIM AN INTEREST AS SPOUSE, HEIRS, DEVISEES, GRANTEEES, OR OTHER CLAIMANTS; CYPRESS LAKE HOMEOWNERS ASSOCIATION OF PASCO, INC., are Defendants.

PAULA S. O'NEIL, The Clerk of the Circuit Court, will sell to the highest bidder for cash, www.pasco.realforeclose.com, at 11:00 AM, on the 21st day of November, 2016, the following described real property as set forth in said

FIRST INSERTION

NOTICE OF FORECLOSURE SALE IN THE CIRCUIT COURT OF THE 6TH JUDICIAL CIRCUIT, IN AND FOR PASCO COUNTY, FLORIDA
CIVIL DIVISION
CASE NO. 51-2012-CA-008371-WS
SELENE FINANCE LP
Plaintiff, vs.
BOBBY BURRIS; PATRICIA BURRIS; UNKNOWN PERSON(S) IN POSSESSION OF THE SUBJECT PROPERTY;
Defendant(s)

NOTICE IS HEREBY GIVEN pursuant to a Final Judgment of Foreclosure dated April 14, 2016, and entered in Case No. 51-2012-CA-008371-WS, of the Circuit Court of the 6th Judicial Circuit in and for Pasco County, Florida, wherein SELENE FINANCE LP is Plaintiff and BOBBY BURRIS; PATRICIA BURRIS; UNKNOWN PERSON(S) IN POSSESSION OF THE SUBJECT PROPERTY; are defendants. PAULA S. O'NEIL, the Clerk of the Circuit Court, will sell to the highest and best bidder for cash BY ELECTRONIC SALE AT: WWW.PASCO.REALFORECLOSE.COM, at 11:00 A.M., on the 15 day of August, 2016, the following described property as set forth in said Final Judgment, to wit:

LOT 995 AND THE NORTH 5 FEET OF LOT 996, EMBASSY HILLS, UNIT SIX, ACCORDING TO THE PLAT THEREOF AS RECORDED IN PLAT BOOK 12, PAGE(S) 145-147, OF THE PUBLIC RECORDS OF PASCO COUNTY, FLORIDA.

A person claiming an interest in the surplus from the sale, if any, other than the lis pendens must file a claim within 60 days after the sale.

This notice is provided pursuant to Administrative Order 2010-045 PA/PI-CIR "If you are a person with disability who needs any accommodation in order to participate in this proceeding, you are entitled, at no cost to you the provision of certain assistance. Please contact Public Information Dept., Pasco County Government Center, 7530 Little Rd., New Port Richey, FL 34654; (727) 847-8110 (V) for proceedings in New Port Richey; (352) 521-4274, ext. 8110 (V) for proceedings in Dade City at least 7 days before your scheduled court appearance, or immediately upon receiving this notification if the time before the scheduled appearance is less than seven (7) days; if you are hearing or voice impaired, call 711."

Dated this 13 day of July, 2016
 Eric M. Knopp, Esq.
 Bar No.: 709921

Submitted by:
 Kahane & Associates, P.A.
 8201 Peters Road, Ste.3000
 Plantation, FL 33324
 Telephone: (954) 382-3486
 Telefacsimile: (954) 382-5380
 Designated service email:
 notice@kahaneandassociates.com
 File No.: 12-06125 SF
 July 22, 29, 2016 16-02075P

FIRST INSERTION

Final Summary Judgment, to wit:

ALL THAT PARCEL OF LAND IN PASCO COUNTY, STATE OF FLORIDA, AS MORE FULLY DESCRIBED IN DEED BOOK 3392, PAGE 1183, ID#14-26-16-010B-00000-0120, BEING KNOWN AND DESIGNATED AS LOT 12, CYPRESS LAKES, UNIT 3, PHASE 1, FILED IN PLAT BOOK 30, PAGE 59. BY FEE SIMPLE DEED FROM CENTRAL HARBOR HOMES CORPORATION AS SET FORTH IN DEED BOOK 3392, PAGE 1183 DATED 02/07/1995 AND RECORDED 02/10/1995, PASCO COUNTY RECORDS, STATE OF FLORIDA.

If you are a person claiming a right to funds remaining after the sale, you must file a claim with the clerk no later than 60 days after the sale. If you fail to file a claim you will not be entitled to any remaining funds. After 60 days, only the owner of record as of the date of the lis pendens may claim the surplus.

If you are a person with a disability who needs an accommodation in order to participate in this proceeding, you are entitled, at no cost to you, to the provision of certain assistance. Please contact:

Public Information Dept., Pasco County Government Center 7530 Little Rd. New Port Richey, FL 34654 Phone: 727.847.8110 (voice) in New Port Richey 352.521.4274, ext 8110 (voice) in Dade City Or 711 for the hearing impaired

Contact should be initiated at least seven days before the scheduled court appearance, or immediately upon receiving this notification if the time before the scheduled appearance is less than seven days.

Dated: July 13, 2016
 By: Elisabeth Porter
 Florida Bar No.: 645648.
 Attorney for Plaintiff:
 Brian L. Rosaler, Esquire

Popkin & Rosaler, P.A.
 1701 West Hillsboro Boulevard
 Suite 400
 Deerfield Beach, FL 33442
 Telephone: (954) 360-9030
 Facsimile: (954) 420-5187
 14-38942
 July 22, 29, 2016 16-02076P

FIRST INSERTION

NOTICE OF FORECLOSURE SALE IN THE CIRCUIT COURT OF THE SIXTH JUDICIAL CIRCUIT, IN AND FOR PASCO COUNTY, FLORIDA
CIVIL DIVISION
CASE NO.:
2013CA003758CAAXWS
CITIMORTGAGE, INC.
Plaintiff, vs.
FIRST NATIONAL TRUST OF AMERICA LLC, et al
Defendants.

NOTICE IS HEREBY GIVEN pursuant to a Final Judgment of foreclosure dated June 23, 2016, and entered in Case No. 2013CA003758CAAXWS of the Circuit Court of the SIXTH Judicial Circuit in and for PASCO COUNTY, Florida, wherein CITIMORTGAGE, INC., is Plaintiff, and FIRST NATIONAL TRUST OF AMERICA LLC, et al are Defendants, the clerk, Paula S. O'Neil, will sell to the highest and best bidder for cash, beginning at 11:00 AM www.pasco.realforeclose.com, in accordance with Chapter 45, Florida Statutes, on the 24 day of August, 2016, the following described property as set forth in said Final Judgment, to wit:

LOT 275, HILLDALE UNIT THREE, ACCORDING TO THE MAP OR PLAT THEREOF AS RECORDED IN PLAT BOOK 12, PAGES 66 AND 67, OF THE PUBLIC RECORDS OF PASCO COUNTY, FLORIDA.

Any person claiming an interest in the surplus funds from the sale, if any, other than the property owner as of the date of the lis pendens must file a claim within 60 days after the sale.

If you are a person with a disability who needs any accommodation to participate in this proceeding, you are entitled, at no cost to you, to the provision of certain assistance. Please contact the Public Information Dept., Pasco County Government Center, 7530 Little Rd., New Port Richey, FL 34654; (727) 847-8110 (V) in New Port Richey; (352) 521-4274, ext 8110 (V) in Dade City, at least 7 days before your scheduled court appearance, or immediately upon receiving this notification if the time before the scheduled appearance is less than seven (7) days; if you are hearing or voice impaired, call 711.

The court does not provide transportation and cannot accommodate for this service. Persons with disabilities needing transportation to court should contact their local public transportation providers for information regarding transportation services.

Dated: July 15, 2016
 By: Heather J. Koch, Esq.,
 Florida Bar No. 89107

Phelan Hallinan
 Diamond & Jones, PLLC
 Attorneys for Plaintiff
 2727 West Cypress Creek Road
 Ft. Lauderdale, FL 33309
 Tel: 954-462-7000
 Fax: 954-462-7001
 Service by email:
 FL.Service@PhelanHallinan.com
 PH # 26976
 July 22, 29, 2016 16-02089P

FIRST INSERTION

NOTICE OF ACTION IN THE CIRCUIT COURT OF THE SIXTH JUDICIAL CIRCUIT IN AND FOR PASCO COUNTY, FLORIDA CIVIL ACTION

CASE NO.: 51-2016-CA-001013ES/J4 DEUTSCHE BANK NATIONAL TRUST COMPANY, AS TRUSTEE FOR GSA HOME EQUITY TRUST 2006-11 ASSET-BACKED CERTIFICATES SERIES 2006-11, Plaintiff, vs. ALBERT LETTERA, et al, Defendant(s).

To: LYNN CUCULLO
Last Known Address: 937 Vincent Ave
Bronx, NY 10465
Current Address: Unknown
ANY AND ALL UNKNOWN PARTIES CLAIMING BY, THROUGH, UNDER, AND AGAINST THE HEREIN NAMED INDIVIDUAL DEFENDANT(S) WHO ARE NOT KNOWN TO BE DEAD OR ALIVE, WHETHER SAID UNKNOWN PARTIES MAY CLAIM AN INTEREST AS SPOUSES, HEIRS, DEVISEES, GRANTEEES, OR OTHER CLAIMANTS
Last Known Address: Unknown
Current Address: Unknown

YOU ARE NOTIFIED that an action to foreclose a mortgage on the following property in Pasco County, Florida:

CONDOMINIUM UNIT NO. 15-202, THE BELMONT AT RYALS CHASE, A CONDOMINIUM, TOGETHER WITH AN UNDIVIDED INTEREST IN THE COMMON ELEMENTS APPURTENANT THERETO, ACCORDING TO THE DECLARATION OF CONDOMINIUM THEREOF, AS RECORDED IN OFFICIAL RECORDS BOOK 6561, AT PAGE 416, OF THE PUBLIC RECORDS OF PASCO COUNTY, FLORIDA.

A/K/A 5924 BRICKLEBERRY LANE, UNIT #15-202, ZEPHYRHILLS, FL 33541

has been filed against you and you are required to serve a copy of your written defenses within 30 days after the first publication, if any, on Albertelli Law, Plaintiff's attorney, whose address is P.O. Box 23028, Tampa, FL 33623, and file the original with this Court either before AUG 22 2016 service on Plaintiff's attorney, or immediately thereafter; otherwise, a default will be entered against you for the relief demanded in the Complaint or petition.

This notice shall be published once a week for two consecutive weeks in the Business Observer.

**See the Americans with Disabilities Act

If you are a person with a disability who needs an accommodation in order to participate in this proceeding, you are entitled, at no cost to you, to the provision of certain assistance. Please contact:

Public Information Dept., Pasco County Government Center, 7530 Little Rd., New Port Richey, FL 34654 Phone: 727.847.8110 (voice) in New Port Richey 352.521.4274, ext 8110 (voice) in Dade City or 711 for the hearing impaired.

Contact should be initiated at least seven days before the scheduled court appearance, or immediately upon receiving this notification if the time before the scheduled appearance is less than seven days.

The court does not provide transportation and cannot accommodate such requests. Persons with disabilities needing transportation to court should contact their local public transportation providers for information regarding transportation services.

WITNESS my hand and the seal of this court on this 14th day of July, 2016.

Paula S. O'Neil, Ph.D.,
Clerk & Comptroller
Clerk of the Circuit Court
By: Gerald Salgado
Deputy Clerk

Albertelli Law
P.O. Box 23028
Tampa, FL 33623
MP - 15-205360
July 22, 29, 2016 16-02127P

FIRST INSERTION

NOTICE OF SALE PURSUANT TO CHAPTER 45 IN THE CIRCUIT COURT OF THE SIXTH JUDICIAL CIRCUIT IN AND FOR PASCO COUNTY, FLORIDA CIVIL ACTION

CASE NO.: 51-2015-CA-003018-WS DEUTSCHE BANK NATIONAL TRUST COMPANY, AS TRUSTEE, IN TRUST FOR REGISTERED HOLDERS OF FIRST FRANKLIN MORTGAGE LOAN TRUST 2005-FFH4, ASSET-BACKED CERTIFICATES, SERIES 2005-FFH4, Plaintiff, vs. PANASIEWICZ, DAMON et al, Defendant(s).

NOTICE IS HEREBY GIVEN Pursuant to a Final Judgment of Foreclosure dated June 23rd, 2016, and entered in Case No. 51-2015-CA-003018-WS of the Circuit Court of the Sixth Judicial Circuit in and for Pasco County, Florida in which Deutsche Bank National Trust Company, as Trustee, in trust for registered Holders of First Franklin Mortgage Loan Trust 2005-FFH4, Asset-Backed Certificates, Series 2005-FFH4, is the Plaintiff and Bruce Lee Panasiewicz, as an Heir of the Estate of Damon Panasiewicz aka Damon Lee Panasiewicz aka Damon L. Panasiewicz, deceased, Dixie Lee Panasiewicz, as an Heir of the Estate of Damon Panasiewicz aka Damon Lee Panasiewicz aka Damon L. Panasiewicz, deceased, Dixie Lee Panasiewicz, as an Heir of the Estate of Damon Panasiewicz aka Damon Lee Panasiewicz, deceased, Embassy Hills Civic Assn. Inc., The Unknown Heirs, Devisees, Grantees, Assignees, Lienors, Creditors, Trustees, or other Claimants claiming by, through, under, or against, Damon Panasiewicz aka Damon Lee Panasiewicz aka Damon L. Panasiewicz, deceased, are defendants, the Pasco County Clerk of the Circuit Court will sell to the highest and best bidder for cash in/on held online www.pasco.realforeclose.com: in Pasco County, Florida, Pasco County, Florida at 11:00 AM on the 17th day of August, 2016, the following described property as set forth in said Final Judgment of Foreclosure:

LOT 2010, EMBASSY HILLS, UNIT TWENTY-ONE, ACCORDING TO THE PLAT THEREOF RECORDED IN PLAT BOOK 16, PAGE 101 AND 102, PUBLIC RECORDS OF PASCO COUNTY, FLORIDA.

7200 Maplehurst Dr, Port Richey, FL 34668

Any person claiming an interest in the surplus from the sale, if any, other than the property owner as of the date of the Lis Pendens must file a claim within 60 days after the sale.

If you are a person with a disability who needs an accommodation in order to participate in this proceeding, you are entitled, at no cost to you, to the provision of certain assistance. Please contact:

Public Information Dept., Pasco County Government Center, 7530 Little Rd., New Port Richey, FL 34654 Phone: 727.847.8110 (voice) in New Port Richey or 352.521.4274, ext 8110 (voice) in Dade City or 711 for the hearing impaired.

Contact should be initiated at least seven days before the scheduled court appearance, or immediately upon receiving this notification if the time before the scheduled appearance is less than seven days.

The court does not provide transportation and cannot accommodate such requests. Persons with disabilities needing transportation to court should contact their local public transportation providers for information regarding transportation services.

Dated in Hillsborough County, Florida, this 18th day of July 2016.

Jennifer Komerak, Esq.
FL Bar # 117796

Albertelli Law
Attorney for Plaintiff
P.O. Box 23028
Tampa, FL 33623
(813) 221-4743
(813) 221-9171 facsimile
eService: servealaw@albertellilaw.com
AH-14-165879
July 22, 29, 2016 16-02112P

Public Information Dept., Pasco County Government Center, 7530 Little Rd., New Port Richey, FL 34654 Phone: 727.847.8110 (voice) in New Port Richey or 352.521.4274, ext 8110 (voice) in Dade City or 711 for the hearing impaired.

Contact should be initiated at least seven days before the scheduled court appearance, or immediately upon receiving this notification if the time before the scheduled appearance is less than seven days.

The court does not provide transportation and cannot accommodate such requests. Persons with disabilities needing transportation to court should contact their local public transportation providers for information regarding transportation services.

Dated in Hillsborough County, Florida, this 18th day of July 2016.

Jennifer Komerak, Esq.
FL Bar # 117796

Albertelli Law
Attorney for Plaintiff
P.O. Box 23028
Tampa, FL 33623
(813) 221-4743
(813) 221-9171 facsimile
eService: servealaw@albertellilaw.com
AH-14-165879
July 22, 29, 2016 16-02112P

Public Information Dept., Pasco County Government Center, 7530 Little Rd., New Port Richey, FL 34654 Phone: 727.847.8110 (voice) in New Port Richey or 352.521.4274, ext 8110 (voice) in Dade City or 711 for the hearing impaired.

Contact should be initiated at least seven days before the scheduled court appearance, or immediately upon receiving this notification if the time before the scheduled appearance is less than seven days.

The court does not provide transportation and cannot accommodate such requests. Persons with disabilities needing transportation to court should contact their local public transportation providers for information regarding transportation services.

Dated in Hillsborough County, Florida, this 18th day of July 2016.

Jennifer Komerak, Esq.
FL Bar # 117796

Public Information Dept., Pasco County Government Center, 7530 Little Rd., New Port Richey, FL 34654 Phone: 727.847.8110 (voice) in New Port Richey or 352.521.4274, ext 8110 (voice) in Dade City or 711 for the hearing impaired.

Contact should be initiated at least seven days before the scheduled court appearance, or immediately upon receiving this notification if the time before the scheduled appearance is less than seven days.

The court does not provide transportation and cannot accommodate such requests. Persons with disabilities needing transportation to court should contact their local public transportation providers for information regarding transportation services.

Dated in Hillsborough County, Florida, this 18th day of July 2016.

Jennifer Komerak, Esq.
FL Bar # 117796

Public Information Dept., Pasco County Government Center, 7530 Little Rd., New Port Richey, FL 34654 Phone: 727.847.8110 (voice) in New Port Richey or 352.521.4274, ext 8110 (voice) in Dade City or 711 for the hearing impaired.

Contact should be initiated at least seven days before the scheduled court appearance, or immediately upon receiving this notification if the time before the scheduled appearance is less than seven days.

The court does not provide transportation and cannot accommodate such requests. Persons with disabilities needing transportation to court should contact their local public transportation providers for information regarding transportation services.

Dated in Hillsborough County, Florida, this 18th day of July 2016.

Jennifer Komerak, Esq.
FL Bar # 117796

Public Information Dept., Pasco County Government Center, 7530 Little Rd., New Port Richey, FL 34654 Phone: 727.847.8110 (voice) in New Port Richey or 352.521.4274, ext 8110 (voice) in Dade City or 711 for the hearing impaired.

Contact should be initiated at least seven days before the scheduled court appearance, or immediately upon receiving this notification if the time before the scheduled appearance is less than seven days.

The court does not provide transportation and cannot accommodate such requests. Persons with disabilities needing transportation to court should contact their local public transportation providers for information regarding transportation services.

Dated in Hillsborough County, Florida, this 18th day of July 2016.

Jennifer Komerak, Esq.
FL Bar # 117796

Public Information Dept., Pasco County Government Center, 7530 Little Rd., New Port Richey, FL 34654 Phone: 727.847.8110 (voice) in New Port Richey or 352.521.4274, ext 8110 (voice) in Dade City or 711 for the hearing impaired.

FIRST INSERTION

NOTICE OF FORECLOSURE SALE IN THE CIRCUIT COURT FOR THE SIXTH JUDICIAL CIRCUIT IN AND FOR PASCO COUNTY, FLORIDA CIVIL DIVISION

CASE NO.: 51-2016-CA-0073-WS DITECH FINANCIAL LLC F/K/A GREEN TREE SERVICING LLC 3000 Bayport Dr Ste 880 Tampa, FL 33607 Plaintiff(s), vs. LILA MACIAK; GARDENS OF BEACON SQUARE CONDOMINIUM NUMBER THREE, INCORPORATED; Defendant(s).

NOTICE IS HEREBY GIVEN THAT, pursuant to Plaintiff's Final Judgment of Foreclosure entered on July 6, 2016, in the above-captioned action, the Clerk of Court, Paula S. O'Neil, will sell to the highest and best bidder for cash at www.pasco.realforeclose.com in accordance with Chapter 45, Florida Statutes on the 31st day of August, 2016, at 11:00 A.M. on the following described property as set forth in said Final Judgment of Foreclosure, to wit:

UNIT C OF BUILDING 3027, GARDENS OF BEACON SQUARE CONDOMINIUM NO. 3, AS DESCRIBED IN THE DECLARATION OF CONDOMINIUM OF THE GARDENS OF BEACON SQUARE CONDOMINIUM NUMBER 3, RECORDED IN O.R. BOOK 539, PAGES 91, AND IN PLAT BOOK 10, PAGES 82-83, PUBLIC RECORDS OF PASCO COUNTY, FLORIDA, TOGETHER WITH ALL APPURTENANCES THERETO DESCRIBED IN THE AFORESAID DECLARATION OF CONDOMINIUM.

PROPERTY ADDRESS: 4221 TAMARGO DR., NEW PORT RICHEY, FL 34652

Any person claiming an interest in the surplus from the sale, if any, other than the property owner as of the date of the lis pendens, must file a claim within sixty (60) days after the sale.

If you are a person with a disability who needs an accommodation in order to participate in this proceeding, you are entitled, at no cost to you, to the provision of certain assistance. Please contact:

Public Information Dept., Pasco County Government Center, 7530 Little Rd., New Port Richey, FL 34654 Phone: 727.847.8110 (voice) in New Port Richey or 352.521.4274, ext 8110 (voice) in Dade City or 711 for the hearing impaired.

Contact should be initiated at least seven days before the scheduled court appearance, or immediately upon receiving this notification if the time before the scheduled appearance is less than seven days.

The court does not provide transportation and cannot accommodate such requests. Persons with disabilities needing transportation to court should contact their local public transportation providers for information regarding transportation services.

Dated in Hillsborough County, Florida, this 18th day of July 2016.

Jennifer Komerak, Esq.
FL Bar # 117796

Public Information Dept., Pasco County Government Center, 7530 Little Rd., New Port Richey, FL 34654 Phone: 727.847.8110 (voice) in New Port Richey or 352.521.4274, ext 8110 (voice) in Dade City or 711 for the hearing impaired.

Contact should be initiated at least seven days before the scheduled court appearance, or immediately upon receiving this notification if the time before the scheduled appearance is less than seven days.

The court does not provide transportation and cannot accommodate such requests. Persons with disabilities needing transportation to court should contact their local public transportation providers for information regarding transportation services.

Dated in Hillsborough County, Florida, this 18th day of July 2016.

Jennifer Komerak, Esq.
FL Bar # 117796

Public Information Dept., Pasco County Government Center, 7530 Little Rd., New Port Richey, FL 34654 Phone: 727.847.8110 (voice) in New Port Richey or 352.521.4274, ext 8110 (voice) in Dade City or 711 for the hearing impaired.

Contact should be initiated at least seven days before the scheduled court appearance, or immediately upon receiving this notification if the time before the scheduled appearance is less than seven days.

The court does not provide transportation and cannot accommodate such requests. Persons with disabilities needing transportation to court should contact their local public transportation providers for information regarding transportation services.

Dated in Hillsborough County, Florida, this 18th day of July 2016.

Jennifer Komerak, Esq.
FL Bar # 117796

Public Information Dept., Pasco County Government Center, 7530 Little Rd., New Port Richey, FL 34654 Phone: 727.847.8110 (voice) in New Port Richey or 352.521.4274, ext 8110 (voice) in Dade City or 711 for the hearing impaired.

Contact should be initiated at least seven days before the scheduled court appearance, or immediately upon receiving this notification if the time before the scheduled appearance is less than seven days.

The court does not provide transportation and cannot accommodate such requests. Persons with disabilities needing transportation to court should contact their local public transportation providers for information regarding transportation services.

Dated in Hillsborough County, Florida, this 18th day of July 2016.

Jennifer Komerak, Esq.
FL Bar # 117796

Public Information Dept., Pasco County Government Center, 7530 Little Rd., New Port Richey, FL 34654 Phone: 727.847.8110 (voice) in New Port Richey or 352.521.4274, ext 8110 (voice) in Dade City or 711 for the hearing impaired.

Contact should be initiated at least seven days before the scheduled court appearance, or immediately upon receiving this notification if the time before the scheduled appearance is less than seven days.

The court does not provide transportation and cannot accommodate such requests. Persons with disabilities needing transportation to court should contact their local public transportation providers for information regarding transportation services.

Pursuant to the Fla. R. Jud. Adm. 2.516, the above signed counsel for Plaintiff designates attorney@padgettlaw.net as its primary e-mail address for service, in the above styled matter, of all pleadings and documents required to be served on the parties.

AMERICANS WITH DISABILITIES ACT: IF YOU ARE A PERSON WITH A DISABILITY WHO NEEDS AN ACCOMMODATION IN ORDER TO PARTICIPATE IN THIS PROCEEDING, YOU ARE ENTITLED, AT NO COST TO YOU, TO THE PROVISION OF CERTAIN ASSISTANCE. PLEASE CONTACT: PUBLIC INFORMATION DEPT., PASCO COUNTY GOVERNMENT CENTER, 7530 LITTLE RD., NEW PORT RICHEY, FL 34654; PHONE: (727)847-8110 (VOICE) IN NEW PORT RICHEY, (352)521-4274, EXT 8110 (VOICE) IN DADE CITY, OR 711 FOR THE HEARING IMPAIRED. CONTACT SHOULD BE INITIATED AT LEAST SEVEN DAYS BEFORE THE SCHEDULED COURT APPEARANCE, OR IMMEDIATELY UPON RECEIVING THIS NOTIFICATION IF THE TIME BEFORE THE SCHEDULED APPEARANCE IS LESS THAN SEVEN DAYS. THE COURT DOES NOT PROVIDE TRANSPORTATION AND CANNOT ACCOMMODATE SUCH REQUESTS. PERSONS WITH DISABILITIES NEEDING TRANSPORTATION TO COURT SHOULD CONTACT THEIR LOCAL PUBLIC TRANSPORTATION PROVIDERS FOR INFORMATION REGARDING TRANSPORTATION SERVICES.

Respectfully submitted,
HARRISON SMALBACH, ESQ.
Florida Bar # 116255

TIMOTHY D. PADGETT, P.A.
6267 Old Water Oak Road, Suite 203
Tallahassee, FL 32312
(850) 422-2520 (telephone)
(850) 422-2567 (facsimile)
attorney@padgettlaw.net
Attorney for Plaintiff

TDP File No. 15-002410-2
July 22, 29, 2016 16-02074P

Public Information Dept., Pasco County Government Center, 7530 Little Rd., New Port Richey, FL 34654 Phone: 727.847.8110 (voice) in New Port Richey or 352.521.4274, ext 8110 (voice) in Dade City or 711 for the hearing impaired.

Contact should be initiated at least seven days before the scheduled court appearance, or immediately upon receiving this notification if the time before the scheduled appearance is less than seven days.

The court does not provide transportation and cannot accommodate such requests. Persons with disabilities needing transportation to court should contact their local public transportation providers for information regarding transportation services.

Dated in Hillsborough County, Florida, this 18th day of July 2016.

Jennifer Komerak, Esq.
FL Bar # 117796

Public Information Dept., Pasco County Government Center, 7530 Little Rd., New Port Richey, FL 34654 Phone: 727.847.8110 (voice) in New Port Richey or 352.521.4274, ext 8110 (voice) in Dade City or 711 for the hearing impaired.

Contact should be initiated at least seven days before the scheduled court appearance, or immediately upon receiving this notification if the time before the scheduled appearance is less than seven days.

The court does not provide transportation and cannot accommodate such requests. Persons with disabilities needing transportation to court should contact their local public transportation providers for information regarding transportation services.

Dated in Hillsborough County, Florida, this 18th day of July 2016.

Jennifer Komerak, Esq.
FL Bar # 117796

Public Information Dept., Pasco County Government Center, 7530 Little Rd., New Port Richey, FL 34654 Phone: 727.847.8110 (voice) in New Port Richey or 352.521.4274, ext 8110 (voice) in Dade City or 711 for the hearing impaired.

Contact should be initiated at least seven days before the scheduled court appearance, or immediately upon receiving this notification if the time before the scheduled appearance is less than seven days.

The court does not provide transportation and cannot accommodate such requests. Persons with disabilities needing transportation to court should contact their local public transportation providers for information regarding transportation services.

Dated in Hillsborough County, Florida, this 18th day of July 2016.

Jennifer Komerak, Esq.
FL Bar # 117796

Public Information Dept., Pasco County Government Center, 7530 Little Rd., New Port Richey, FL 34654 Phone: 727.847.8110 (voice) in New Port Richey or 352.521.4274, ext 8110 (voice) in Dade City or 711 for the hearing impaired.

Contact should be initiated at least seven days before the scheduled court appearance, or immediately upon receiving this notification if the time before the scheduled appearance is less than seven days.

The court does not provide transportation and cannot accommodate such requests. Persons with disabilities needing transportation to court should contact their local public transportation providers for information regarding transportation services.

Dated in Hillsborough County, Florida, this 18th day of July 2016.

Jennifer Komerak, Esq.
FL Bar # 117796

Public Information Dept., Pasco County Government Center, 7530 Little Rd., New Port Richey, FL 34654 Phone: 727.847.8110 (voice) in New Port Richey or 352.521.4274, ext 8110 (voice) in Dade City or 711 for the hearing impaired.

Contact should be initiated at least seven days before the scheduled court appearance, or immediately upon receiving this notification if the time before the scheduled appearance is less than seven days.

The court does not provide transportation and cannot accommodate such requests. Persons with disabilities needing transportation to court should contact their local public transportation providers for information regarding transportation services.

FIRST INSERTION

NOTICE OF FORECLOSURE SALE PURSUANT TO CHAPTER 45 IN THE CIRCUIT COURT OF THE SIXTH JUDICIAL CIRCUIT IN AND FOR PASCO COUNTY, FLORIDA

CASE NO.: 51-2014-CA-001126ES/GSMP'S MORTGAGE LOAN TRUST 2005-RP2, MORTGAGE PASS-THROUGH CERTIFICATES, SERIES 2005-RP2, U.S. BANK NATIONAL ASSOCIATION, AS TRUSTEE, SUCCESSOR-IN-INTEREST TO WACHOVIA BANK NATIONAL ASSOCIATION, AS TRUSTEE, Plaintiff, vs. LEONARD M. MALAVET A/K/A LEONARD MALAVET; BRANDI M. MALAVET A/K/A BRANDI MALAVET A/K/A BRANDI MICHELLE HAMBERG; et al., Defendant(s).

NOTICE IS HEREBY GIVEN that sale will be made pursuant to an Order or Final Judgment. Final Judgment was awarded on April 28, 2015 in Civil Case No. 51-2014-CA-001126ES, of the Circuit Court of the SIXTH Judicial Circuit in and for Pasco County, Florida, wherein, GSMP'S MORTGAGE LOAN TRUST 2005-RP2, MORTGAGE PASS-THROUGH CERTIFICATES, SERIES 2005-RP2, U.S. BANK NATIONAL ASSOCIATION, AS TRUSTEE, SUCCESSOR-IN-INTEREST TO WACHOVIA BANK NATIONAL ASSOCIATION, AS TRUSTEE, AS TRUSTEE, and LEONARD M MALAVET; BRANDI M MALAVET AKA BRANDI MICHELLE HAMBERG; SABLE RIDGE HOMEOWNERS ASSOCIATION, INC.; COLLIER PARKWAY MAINTENANCE ASSOCIATION, INC.; CLERK OF COURT OF PASCO COUNTY; STATE OF FLORIDA - DEPARTMENT OF REVENUE; TENANT 1 NKA THOMAS BALDWIN; TENANT 2 NKA ANAIS COLON; TENANT 3 NKA JEREMY COLON; ANY AND ALL UNKNOWN PARTIES CLAIMING BY, THROUGH, UNDER AND AGAINST THE HEREIN NAMED INDIVIDUAL DEFENDANT(S) WHO ARE NOT KNOWN TO BE DEAD OR ALIVE, WHETHER SAID UN-

KNOWN PARTIES MAY CLAIM AN INTEREST AS SPOUSES, HEIRS, DEVISEES, GRANTEEES, OR OTHER CLAIMANTS are Defendants.

The clerk of the court, Paula S. O'Neil Ph.D. will sell to the highest bidder for cash www.pasco.realforeclose.com on August 11, 2016 at 11:00 AM; the following described real property as set forth in said Final Judgment, to wit:

LOT 58, SABLE RIDGE, PHASE 6A1, ACCORDING TO MAP OR PLAT THEREOF RECORDED IN PLAT BOOK 38, PAGES 130 THROUGH 132, OF THE PUBLIC RECORDS OF PASCO COUNTY, FLORIDA.

ANY PERSON CLAIMING AN INTEREST IN THE SURPLUS FROM THE SALE, IF ANY, OTHER THAN THE PROPERTY OWNER AS OF THE DATE OF THE LIS PENDENS MUST FILE A CLAIM WITHIN 60 DAYS AFTER THE SALE.

IMPORTANT

AMERICANS WITH DISABILITIES ACT: If you are a person with a disability who needs an accommodation in order to participate in this proceeding, you are entitled, at no cost to you, to the provision of certain assistance. Please contact: Public Information Dept., Pasco County Government Center, 7530 Little Rd., New Port Richey, FL 34654; Phone: 727.847.8110 (voice) in New Port Richey, 352.521.4274, ext 8110 (voice) in Dade City, or 711 for the hearing impaired. Contact should be initiated at least seven days before the scheduled court appearance, or immediately upon receiving this notification if the time before the scheduled appearance is less than seven days.

Dated this 19 day of July, 2016.

By: Susan Sparks - FBN 33626
Primary E-Mail:

ServiceMail@aldridgepita.com

ALDRIDGE | PITE, LLP
Attorney for Plaintiff
1615 South Congress Avenue Suite 200
Delray Beach, FL 33445
Telephone: (844) 470-8804
Facsimile: (561) 392-6965
1468-148B
July 22, 29, 2016 16-02134P

FIRST INSERTION

NOTICE OF ACTION IN THE CIRCUIT COURT OF THE SIXTH JUDICIAL CIRCUIT IN AND FOR PASCO COUNTY, FLORIDA CIVIL ACTION

CASE NO.: 51-2016-CA-001402WS WELLS FARGO BANK, N.A., Plaintiff, vs. THE UNKNOWN HEIRS, DEVISEES, GRANTEEES, ASSIGNEES, LIENORS, CREDITORS, TRUSTEES, OR OTHER CLAIMANTS CLAIMING BY, THROUGH, UNDER, OR AGAINST, OSCAR DELGADO A/K/A OSCAR DELGADO RAMOS A/K/A OSCAR DELGADO-RAMOS, DECEASED, et al, Defendant(s).

To: THE UNKNOWN HEIRS, DEVISEES, GRANTEEES, ASSIGNEES, LIENORS, CREDITORS, TRUSTEES, OR OTHER CLAIMANTS CLAIMING BY, THROUGH, UNDER, OR AGAINST, OSCAR DELGADO A/K/A OSCAR DELGADO RAMOS A/K/A OSCAR DELGADO-RAMOS, DECEASED

Last Known Address: Unknown
Current Address: Unknown

ANY AND ALL UNKNOWN PARTIES CLAIMING BY, THROUGH

FIRST INSERTION

RE-NOTICE OF SALE
PURSUANT TO CHAPTER 45
IN THE CIRCUIT COURT OF THE
6th JUDICIAL CIRCUIT, IN AND
FOR PASCO COUNTY, FLORIDA.
CASE No.: 2013 CA 006401
**THE BANK OF NEW YORK
MELLON FKA THE BANK OF
NEW YORK, AS SUCCESSOR
IN INTEREST TO JPMORGAN
CHASE BANK, N.A., AS TRUSTEE
FOR NOVASTAR MORTGAGE
FUNDING TRUST, SERIES 2006-2,
NOVASTAR HOME EQUITY LOAN
ASSET - BACKED CERTIFICATES,
2006-2,**
Plaintiffs, vs.
**ANTHONY J. CLAYCOMB, ET AL.,
Defendants.**
NOTICE OF SALE IS HEREBY
GIVEN pursuant to a Uniform Final
Judgment of Foreclosure dated
March 2, 2016, and entered in Case
No. 2013 CA 006401 of the Circuit
Court of the 6th Judicial Circuit
in and for Pasco County, Florida,
wherein THE BANK OF NEW
YORK MELLON FKA THE BANK
OF NEW YORK, AS SUCCESSOR
IN INTEREST TO JPMORGAN
CHASE BANK, N.A., AS TRUSTEE
FOR NOVASTAR MORTGAGE
FUNDING TRUST, SERIES 2006-2,
NOVASTAR HOME EQUITY LOAN
ASSET - BACKED CERTIFICATES,
2006-2, is Plaintiff, and ANTHONY
J. CLAYCOMB, ET AL., are the Def-
endants, the Office of Paula S. O'Neil,
Pasco County Clerk of the Court will
sell to the highest and best bidder for
cash via online auction at [www.pasco.
realforeclose.com](http://www.pasco.realforeclose.com) at 11:00 A.M. on
the 18th day of August, 2016, the fol-
lowing described property as set forth

in said Final Judgment, to wit:
Lot Nine Hundred Ninety-
Eight, of the unrecorded plat of
Jasmine Lakes, Unit Seven: a
portion of the Southeast 1/4 of
Section 15, Township 25 South,
Range 16 East, Pasco County,
Florida, being further described
as follows:
Commence at the Southwest
corner of the Southeast 1/4 of
said Section 15; thence run along
the West line of the Southeast
1/4 of said Section 15, North 0
degree15'00" East, a distance
of 518.89 feet; thence South 89
degrees 43' 05" East, a distance
of 734.83 feet; thence North 0
degree16'55" East, a distance of
125.00 feet; thence South 89°43'
05" East, a distance of 975.00
feet; thence North 0 degree16'
55" East, a distance of 1030.00
feet for a Point of Beginning;
thence North 89 degrees 43'
05" West, a distance of 100
feet; thence North 0 degrees16'
55" East, a distance of 65 feet;
thence South 89 degrees 43'
05" East, a distance of 100 feet;
thence South 0 degree 16' 55"
West, a distance of 65 feet to the
Point of Beginning; the West 10
feet and the South 3 feet thereof
being subject to an easement for
Drainage and/or Utilities. This
being a description of Lot 998,
Unit 7-B, Plat Book 12, Page(s)
80, 81 and 82, of the Public Re-
cords of Pasco County, Florida,
the said Lot 998 being noted as
not being included in this plat.
Property Address: 10309 Garde-
nia Lane, Port Richey, FL 34668

and all fixtures and personal property
located therein or thereon, which are
included as security in Plaintiff's mort-
gage.
Any person claiming an interest in
the surplus funds from the sale, if any,
other than the property owner as of the
date of the lis pendens must file a claim
within 60 days after the sale.
If you are a person with a disabili-
ty who needs any accommodation in
order to participate in this proceed-
ing, you are entitled, at no cost to you,
to the provision of certain assistance.
Please contact the Public Information
Dept., Pasco County Government Cen-
ter, 7530 Little Rd., New Port Richey,
FL 34654; (727) 847-8110 (V) in New
Port Richey; (352) 521-4274, ext 8110
(V) in Dade City, at least 7 days before
your scheduled court appearance, or
immediately upon receiving this notifi-
cation if the time before the scheduled
appearance is less than 7 days; if you
are hearing impaired call 711. The court
does not provide transportation and
cannot accommodate for this service.
Persons with disabilities needing trans-
portation to court should contact their
local public transportation providers
for information regarding transporta-
tion services.
Dated this 18th day of July, 2016.
By: Jared Lindsey, Esq.
FBN: 081974
Clarfield, Okon, Salomone
& Pincus, P.L.
500 S. Australian Avenue,
Suite 730
West Palm Beach, FL 33401
Telephone: (561) 713-1400
Facsimile: (561) 713-1401
Email: pleadings@copslaw.com
July 22, 29, 2016 16-02115P

FIRST INSERTION

NOTICE OF ACTION
IN THE CIRCUIT COURT OF THE
SIXTH JUDICIAL CIRCUIT IN AND
FOR PASCO COUNTY, FLORIDA
CIVIL ACTION
CASE NO.:
2016CA001401CAAXWS
DIVISION: J3/J7
DITECH FINANCIAL LLC,
Plaintiff, vs.
**THE UNKNOWN HEIRS,
DEVISEES, GRANTEES,
ASSIGNEES, LIENORS,
CREDITORS, TRUSTEES, OR
OTHER CLAIMANTS CLAIMING
BY, THROUGH, UNDER, OR
AGAINST, ESTELLE PULLANO,
DECEASED, et al,
Defendant(s).**
To: THE UNKNOWN HEIRS, DE-
VISEES, GRANTEES, ASSIGNEES,
LIENORS, CREDITORS, TRUSTEES,
OR OTHER CLAIMANTS CLAIM-
ING BY, THROUGH, UNDER, OR
AGAINST, ESTELLE PULLANO, DE-
CEASED
Last Known Address: Unknown
Current Address: Unknown
ANY AND ALL UNKNOWN PAR-
TIES CLAIMING BY, THROUGH,
UNDER, AND AGAINST THE
HEREIN NAMED INDIVIDUAL
DEFENDANT(S) WHO ARE NOT
KNOWN TO BE DEAD OR ALIVE,
WHETHER SAID UNKNOWN PAR-
TIES MAY CLAIM AN INTEREST
AS SPOUSES, HEIRS, DEVISEES,
GRANTEES, OR OTHER CLAIM-
ANTS
Last Known Address: Unknown

Current Address: Unknown
YOU ARE NOTIFIED that an action
to foreclose a mortgage on the following
property in Pasco County, Florida:
UNIT 102, BUILDING 2, LAKE
KIMBERLY VILLAGE CON-
DOMINIUM, TOGETHER
WITH AN UNDIVIDED IN-
TEREST IN THE COMMON
ELEMENTS APPURTENANT
THERE TO, ACCORDING TO
THE MAP OR PLAT THERE-
OF, AS RECORDED IN CON-
DOMINIUM PLAT BOOK 3,
PAGE 11, AND BEING FUR-
THER DESCRIBED IN THAT
CERTAIN DECLARATION OF
CONDOMINIUM RECORD-
ED IN OFFICIAL RECORDS
BOOK 1557, PAGE 1763, ET
SEQ., AND ANY AMEND-
MENTS THERETO, OF THE
PUBLIC RECORDS OF PASCO
COUNTY, FLORIDA.
A/K/A 9016 SHALLOWFORD
LN 102, PORT RICHEY, FL
34668
has been filed against you and you are
required to serve a copy of your written
defenses within 30 days after the first
publication, if any, on Albertelli Law,
Plaintiff's attorney, whose address is
P.O. Box 23028, Tampa, FL 33623, and
file the original with this Court either
before 8/22/16 service on Plaintiff's at-
torney, or immediately thereafter; oth-
erwise, a default will be entered against
you for the relief demanded in the Com-
plaint or petition.
This notice shall be published once a

week for two consecutive weeks in the
Business Observer.
**See the Americans with Disabilities
Act
If you are a person with a disability
who needs an accommodation in order
to participate in this proceeding, you
are entitled, at no cost to you, to the
provision of certain assistance. Please
contact:
Public Information Dept., Pasco
County Government Center, 7530 Little
Rd., New Port Richey, FL 34654 Phone:
727.847.8110 (voice) in New Port Richey
352.521.4274, ext 8110 (voice) in Dade
City or 711 for the hearing impaired.
Contact should be initiated at least
seven days before the scheduled court
appearance, or immediately upon re-
ceiving this notification if the time be-
fore the scheduled appearance is less
than seven days.
The court does not provide trans-
portation and cannot accommodate
such requests. Persons with disabilities
needing transportation to court should
contact their local public transportation
providers for information regarding
transportation services.
WITNESS my hand and the seal of
this court on this 12 day of July, 2016.
Paula S. O'Neil, Ph.D.,
Clerk & Comptroller
By: Carmella Hernandez
Deputy Clerk
Albertelli Law
P.O. Box 23028
Tampa, FL 33623
EF - 16-001328
July 22, 29, 2016 16-02113P

FIRST INSERTION

NOTICE OF FORECLOSURE SALE
PURSUANT TO CHAPTER 45
IN THE CIRCUIT COURT OF THE
SIXTH JUDICIAL CIRCUIT IN AND
FOR PASCO COUNTY, FLORIDA
CASE NO.:
2013-CA-005702-WS
BANK OF AMERICA, N.A.,
Plaintiff, vs.
EVELYN PARKER; et al.,
Defendant(s).
NOTICE IS HEREBY GIVEN that sale
will be made pursuant to an Order or
Final Judgment. Final Judgment was
awarded on June 16, 2016 in Civil Case
No. 2013-CA-005702-WS, of the Cir-
cuit Court of the SIXTH Judicial Cir-
cuit in and for Pasco County, Florida,
wherein, BANK OF AMERICA, N.A.
is the Plaintiff, and EVELYN PARK-
ER; UNKNOWN TENANT #1 N/K/A
CRYSTAL CANOVAN; SPRINGCAS-
TLE AMERICA FUNDING TRUST,
THROUGH ITS TRUSTEE WILM-
INGTON NATIONAL ASSOCIATION;
WELLS FARGO BANK, NA, SUCCE-
SOR TO SOUTHTRUST BANK, NA-
TIONAL ASSOCIATION; AND ANY AND
ALL UNKNOWN PARTIES CLAIM-
ING BY, THROUGH, UNDER AND
AGAINST THE HEREIN NAMED
INDIVIDUAL DEFENDANT(S) WHO
ARE NOT KNOWN TO BE DEAD
OR ALIVE, WHETHER SAID UN-
KNOWN PARTIES MAY CLAIM AN
INTEREST AS SPOUSES, HEIRS,
DEVISEES, GRANTEES, OR OTHER
CLAIMANTS are Defendants.
The clerk of the court, Paula O'Neil,
Ph.D. will sell to the highest bidder for
cash at [www.pasco.
realforeclose.com](http://www.pasco.realforeclose.com) on
August 10, 2016 at 11:00 AM, the fol-
lowing described real property as set
forth in said Final Judgment, to wit:

TRACT 77 OF THE UNRE-
CORDED PLAT OF COLONY
VILLAGE UNIT TWO BEING
FURTHER DESCRIBED AS
FOLLOWS: COMMENCING
AT THE SW CORNER OF THE
SE 1/4 OF SECTION 32, TOWN-
SHIP 24 SOUTH, RANGE
17 EAST, PASCO COUNTY
FLORIDA, GO THENCE N 89
DEG 57' 21" E, A DISTANCE
OF 546.02 FEET; THENCE N
07 DEG 07'08"W, A DISTANCE
OF 916.41 FEET; THENCE N
54 DEG 59' 48" E, A DISTANCE
OF 785.00 FEET; THENCE N
06 DEG 51' 53" E, A DISTANCE
OF 618.30 FEET; THENCE N
89 DEG 54' 50" E, A DISTANCE
OF 78.85 FEET TO THE POINT
OF BEGINNING; THENCE
CONTINUE N 89 DEG 54'50" E,
A DISTANCE OF 310.17 FEET;
THENCE S 11 DEG 42'22" E, A
DISTANCE OF 379.74 FEET TO
A POINT ON A CURVE HAV-
ING A CENTRAL ANGLE OF
25 DEG 24' 31", A RADIUS OF
196.40 FEET, A TANGENT OF
44.27 FEET, A CHORD BEAR-
ING AND DISTANCE OF S
65 DEG 33' 22" W, AND 86.38
FEET, THENCE ALONG SAID
CURVE AN ARC DISTANCE
OF 87.09 FEET; THENCE
N 37 DEG 08' 53" W, A DIS-
TANCE OF 510.81 FEET TO
THE POINT OF BEGINNING.
TOGETHER WITH 1997 REGE
MOBILE HOMES VIN NUM-
BERS N16275A AND N16275B
ANY PERSON CLAIMING AN IN-
TEREST IN THE SURPLUS FROM
THE SALE, IF ANY, OTHER THAN

THE PROPERTY OWNER AS OF
THE DATE OF THE LIS PENDENS
MUST FILE A CLAIM WITHIN 60
DAYS AFTER THE SALE.
IMPORTANT
AMERICANS WITH DISABILI-
TIES ACT: If you are a person with a
disability who needs an accommodation
in order to participate in this proceed-
ing, you are entitled, at no cost to you,
to the provision of certain assistance.
Please contact: Public Information
Dept., Pasco County Government Cen-
ter, 7530 Little Rd., New Port Richey,
FL 34654; Phone: 727.847.8110 (voice)
in New Port Richey, 352.521.4274, ext
8110 (voice) in Dade City, Or 711 for the
hearing impaired. Contact should be
initiated at least seven days before the
scheduled court appearance, or immedi-
ately upon receiving this notification
if the time before the scheduled appear-
ance is less than seven days. The court
does not provide transportation and
cannot accommodate such requests.
Persons with disabilities needing trans-
portation to court should contact their
local public transportation providers
for information regarding transporta-
tion services.
Dated this 15 day of July, 2016.
By: Susan Sparks - FBN 33626
for Susan W. Findley, Esq.
FBN: 160600
Primary E-Mail:
ServiceMail@aldridgepate.com
ALDRIDGE | PITE, LLP
Attorney for Plaintiff
1615 South Congress Avenue Suite 200
Delray Beach, FL 33445
Telephone: (844) 470-8804
Facsimile: (561) 392-6965
1092-7452B
July 22, 29, 2016 16-02093P

FIRST INSERTION

NOTICE OF SALE
PURSUANT TO CHAPTER 45
IN THE CIRCUIT COURT OF THE
SIXTH JUDICIAL CIRCUIT IN AND
FOR PASCO COUNTY, FLORIDA
CIVIL ACTION
CASE NO.:
2015CA001229CAAXES
**DEUTSCHE BANK NATIONAL
TRUST COMPANY, AS TRUSTEE
UNDER THE POOLING AND
SERVICING AGREEMENT
RELATING TO IMPAC SECURED
ASSETS CORP., MORTGAGE
PASS-THROUGH CERTIFICATES,
SERIES 2007-2,**
Plaintiff, vs.
**NOURY, BRENT et al,
Defendant(s).**
NOTICE IS HEREBY GIVEN Pursuant
to a Final Judgment of Foreclosure
dated 6 April, 2016, and entered in
Case No. 2015CA001229CAAXES of
the Circuit Court of the Sixth Judicial
Circuit in and for Pasco County, Florida
in which Deutsche Bank National Trust
Company, As Trustee Under The Pool-
ing And Servicing Agreement Relating
To Impac Secured Assets Corp., Mort-
gage Pass-through Certificates, Series
2007-2, is the Plaintiff and Brent Noury
aka Brent A. Noury, Deutsche Bank Na-
tional Trust Company, as Trustee Under
the Pooling and Servicing Agreement
Relating to IMPAC Secured Assets
Corp., Mortgage Pass-Through Certifi-
cates, Series 2007-3, Florida Irrigation
Supply, Inc., IMPAC Funding Corpora-
tion, John Deere Landscapes, Inc., a
dissolved Delaware corporation, by and
through David P. Werning, its Presi-

dent, Unknown Party #1 nka Michelle
Lindsay, And Any and All Unknown
Parties Claiming By, Through, Under,
and Against The Herein Named In-
dividual Defendant(s) Who Are Not
Known to be Dead or Alive, Whether
Said Unknown Parties May Claim an
Interest in Spouses, Heirs, Devisees,
Grantees, or Other Claimants, are de-
fendants, the Pasco County Clerk of the
Circuit Court will sell to the highest and
best bidder for cash in/on held online
[www.pasco.
realforeclose.com](http://www.pasco.realforeclose.com): in Pasco
County, Florida, Pasco County, Florida
at 11:00 AM on the 15th of August,
2016, the following described property
as set forth in said Final Judgment of
Foreclosure:
THE EAST 1/2 OF TRACT 123,
IN SECTION 15, TOWNSHIP
26 SOUTH, RANGE 21 EAST,
ZEPHYRHILLS COLONY CLUB,
AS PER PLAT THEREOF, RE-
CORDED IN PLAT BOOK 1 PAGE
55 OF THE PUBLIC RECORDS
OF PASCO COUNTY, FLORIDA
TOGETHER WITH A MOBILE
HOME AS A PERMANENT FIX-
TURE AND APPURTENANCE
THERE TO, DESCRIBED AS: A
1978, MANUFACTURER, DIAM
SINGLEWIDE MOBILE HOME,
MOBILE HOME BEARING
IDENTIFICATION NUMBER
GDWTGA19762330 AND TITLE
NUMBER 15419959
37329 TUCKER ROAD, ZEPHY-
RHILLS, FL 33541
Any person claiming an interest in the
surplus from the sale, if any, other than
the property owner as of the date of the

Lis Pendens must file a claim within 60
days after the sale.
If you are a person with a disability
who needs an accommodation in order
to participate in this proceeding, you
are entitled, at no cost to you, to the
provision of certain assistance. Please
contact:
Public Information Dept., Pasco
County Government Center, 7530
Little Rd., New Port Richey, FL 34654
Phone: 727.847.8110 (voice) in New
Port Richey or 352.521.4274, ext 8110
(voice) in Dade City or 711 for the hear-
ing impaired.
Contact should be initiated at least
seven days before the scheduled court
appearance, or immediately upon re-
ceiving this notification if the time be-
fore the scheduled appearance is less
than seven days.
The court does not provide trans-
portation and cannot accommodate
such requests. Persons with disabilities
needing transportation to court should
contact their local public transportation
providers for information regarding
transportation services.
Dated in Hillsborough County, Flor-
ida this 13th day of July, 2016.
Andrea Alles, Esq.
FL Bar # 114757
Albertelli Law
Attorney for Plaintiff
P.O. Box 23028
Tampa, FL 33623
(813) 221-4743
(813) 221-9171 facsimile
eService: servealaw@albertellilaw.com
JR-14-166898
July 22, 29, 2016 16-02078P

FIRST INSERTION

NOTICE OF ACTION
IN THE CIRCUIT COURT OF THE
6TH JUDICIAL CIRCUIT, IN AND
FOR PASCO COUNTY, FLORIDA.
CASE No.
2016-CA-001266-CAAX-WS
21ST MORTGAGE CORPORATION,
Plaintiff vs.
**MARC A. RUIZ AKA MARC
ANTHONY RUIZ, et al.,**
Defendants
TO: MARC A. RUIZ AKA MARC AN-
THONY RUIZ
15910 WEST LAKE BURRELL DR
APT B
LUTZ, FL 33549 3592
MARC A. RUIZ AKA MARC ANTHONY
RUIZ
1734 ANNA ROAD
ODESSA, FL 33556
MARC A. RUIZ AKA MARC ANTHONY
RUIZ
5215 S WEST SHORE BLVD APT 65
TAMPA, FL 33611
MARC A. RUIZ AKA MARC ANTHONY
RUIZ
1734 E ANNONA AVE
TAMPA, FL 33612
STEPHANIE L. RUIZ AKA STEPHANIE
LYNN RUIZ
15203 TALL CEDAR DR
TAMPA, FL 33613
STEPHANIE L. RUIZ AKA STEPHANIE
LYNN RUIZ
1734 ANNA ROAD
ODESSA, FL 33556
STEPHANIE L. RUIZ AKA STEPHANIE
LYNN RUIZ
15910 WEST LAKE BURRELL DR
APT B
LUTZ, FL 33549 3592
STEPHANIE L. RUIZ AKA STEPHANIE
LYNN RUIZ
2564 W BIRD ST

TAMPA, FL 33614
STEPHANIE L. RUIZ AKA STEPHANIE
LYNN RUIZ
1290 WALL ST
LYNDHURST, NJ 07071
AND TO: All persons claiming an in-
terest by, through, under, or against the
aforesaid Defendant(s).
YOU ARE HEREBY NOTIFIED that
an action to foreclose a mortgage on the
following described property located in
Pasco County, Florida:
LOT 20:
THE SOUTH 131 FEET LESS
THE WEST 481.5 FEET
THEREOF, OF TRACT 5, IN
THE NORTHWEST 1/4 OF
SECTION 36, TOWNSHIP 26
SOUTH, RANGE 17 EAST, RE-
VISED MAP OF KEYSTONE
PARK COLONY, AS RECORDED
IN PLAT BOOK 1, PAGE 64,
OF THE PUBLIC RECORDS
OF PASCO COUNTY, FLORI-
DA.
SUBJECT TO AN EASEMENT
OVER AND ACROSS THE
WEST 15 FEET FOR RIGHT-
OF-WAY. LESS TEH SOUTH
10 FEET FOR ROAD RIGHT
OF WAY BEING SUBJECT TO
WARRANTY DEED DATED
4/2/1984, RECORDED IN
O.R. BOOK 1329, PAGE 384,
PUBLIC RECORDS OF PASCO
COUNTY, FLORIDA.
TOGETHER WITH A 2014
CHAMPION MANUFAC-
TURED HOME, CVSLV1000
MODEL, 60 X 32, WITH A
SERIAL NUMBER OF FL-
26100PHA100928A AND FL-
26100PHA100928B
has been filed against you, and you are

required to serve a copy of your writ-
ten defenses, if any, to this action, on
Greenspoon Marder, P.A., Default De-
partment, Attorneys for Plaintiff, whose
address is Trade Centre South, Suite
700, 100 West Cypress Creek Road,
Fort Lauderdale, FL 33309, and the file
original with the Clerk within 30 days
after the first publication of this notice,
in THE BUSINESS OBSERVER in the
on or before 8/22/16, 2016; otherwise
a default and a judgment may be entered
against you for the relief demanded in
the Complaint.
IMPORTANT
In accordance with the Americans
with Disabilities Act, persons needing
a reasonable accommodation to par-
ticipate in this proceeding should, no
later than seven (7) days prior, contact
the Clerk of the Court's disability coor-
dinator at PUBLIC INFORMATION
DEPARTMENT, PASCO COUNTY
GOVERNMENT CENTER, 7530
LITTLE ROAD, NEW PORT RICHEY,
FL 34654, 727-847-8110. If hear-
ing or voice impaired, contact (TDD)
(800)955-8771 via Florida Relay Sys-
tem.
WITNESS MY HAND AND SEAL
OF SAID COURT on this 12 day of July
2016.
Paula S. O'Neil, Ph.D.,
Clerk & Comptroller
By: Carmella Hernandez
As Deputy Clerk
Greenspoon Marder, P.A.
Default Department
Attorneys for Plaintiff
Trade Centre South, Suite 700
100 West Cypress Creek Road
Fort Lauderdale, FL 33309
(353)83.0341/DWagner)
July 22, 29, 2016 16-02124P

FIRST INSERTION

RE-NOTICE OF
FORECLOSURE SALE
IN THE CIRCUIT COURT OF THE
6TH JUDICIAL CIRCUIT, IN AND
FOR PASCO COUNTY, FLORIDA
CIVIL DIVISION:
CASE NO.:
51-2013-CA-002498-CAAX-ES
**FEDERAL NATIONAL MORTGAGE
ASSOCIATION,**
Plaintiff, vs.
**NANCY BATAILLE A/K/A NANCY
L. CRIST; UNKNOWN SPOUSE
OF NANCY BATAILLE A/K/A
NANCY L. CRIST; UNKNOWN
TENANT I; UNKNOWN TENANT
II; PASCO COUNTY, A POLITICAL
SUBDIVISION OF THE STATE OF
FLORIDA, and any unknown heirs,
devisees, grantees, creditors, and
other unknown persons or unknown
spouse claiming by, through and
under any of the above-named
Defendants.**
NOTICE IS HEREBY GIVEN pursuant
to an Order Resetting Foreclosure
Sale dated the 7th day of June 2016
and entered in Case No. 51-2013-CA-
002498-CAAX-ES, of the Circuit
Court of the 6TH Judicial Circuit in
and for Pasco County, Florida, where-
in FEDERAL NATIONAL MORT-
GAGE ASSOCIATION ("FNMA") is
the Plaintiff and NANCY BATAILLE
A/K/A NANCY L. CRIST; UN-
KNOWN SPOUSE OF NANCY BA-
TAILLE A/K/A NANCY L. CRIST;
PASCO COUNTY, A POLITICAL
SUBDIVISION OF THE STATE OF
FLORIDA; UNKNOWN SPOUSE
OF NANCY BATAILLE A/K/A
NANCY L. CRIST AND UNKNOWN
TENANT (S) IN POSSESSION OF
THE SUBJECT PROPERTY are
defendants. The Clerk of this Court
shall sell to the highest and best bid-
der for cash, on the 9th day of August
2016 at 11:00 AM on Pasco County's
Public Auction website: [www.pasco.
realforeclose.com](http://www.pasco.
realforeclose.com), pursuant to judg-
ment or order of the Court, in accor-

dance with Chapter 45, Florida Stat-
utes, the following described property
as set forth in said Final Judgment,
to wit:
PLEASE SEE ATTACHED
EXHIBIT "A"
PARCEL 20:
THE S-1/2 OF THE SE 1/4 OF
THE SW 1/4 OF THE NW 1/4
OF SECTION 34, TOWNSHIP
23 SOUTH, RANGE 21 EAST,
PASCO COUNTY, FLORIDA.
SUBJECT TO AN EASEMENT
FOR INGRESS-EGRESS
AND UTILITIES OVER THE
SOUTH 30.00 FEET AND THE
WEST 30.00 FEET OF THE
S-1/2 OF THE SE 1/4 OF THE
SW 1/4 OF THE NW 1/4; THE
NORTH 30.00 FEET OF THE
SOUTH 50.00 FEET OF THE
W-1/2 OF THE E-1/2 OF THE
W-1/2 OF THE NW 1/4; AND,
THE WEST 60.00 FEET OF
THE NORTH 30.00 FEET OF
THE SOUTH 60.00 FEET OF
THE E-1/2 OF THE E-1/2 OF
THE W-1/2 OF THE NW 1/4,
IN SECTION 34, TOWNSHIP
23 SOUTH, RANGE 21 EAST.
TOGETHER WITH AN EASE-
MENT FOR INGRESS-EGRESS
AND UTILITIES OVER THE
WEST 30.00 FEET OF THE
E-1/2 OF THE W-1/2 OF THE
NW 1/4; AND, THE EAST
30.00 FEET OF THE W-1/2 OF
THE W-1/2 OF THE NW 1/4, IN
SECTION 34, TOWNSHIP 23
SOUTH, RANGE 21 EAST.
AND, THE EAST 30.00 FEET
AND THE NORTH 30.00 FEET
OF THE W-1/2 OF THE W-1/2
OF THE S-3/4 OF THE SW 1/4;
THE WEST 30.00 FEET OF
THE E-1/2 OF THE W-1/2 OF
THE S-3/4 OF THE SW 1/4;
THE SOUTH 30.00 FEET OF
THE WEST 30.00 FEET OF
THE E-1/2 OF THE N-1/2 OF
THE NW 1/4 OF THE SW 1/4;
AND THE SOUTH 30.00 FEET

OF THE W-1/2 OF THE N-1/2
OF THE NW 1/4 OF THE SW
1/4, IN SECTION 27, TOWN-
SHIP 23 SOUTH, RANGE 21
EAST.
EXHIBIT A
ANY PERSON CLAIMING AN IN-
TEREST IN THE SURPLUS FROM
THE SALE, IF ANY, OTHER THAN
THE PROPERTY OWNER AS OF
THE DATE OF THE LIS PENDENS
MUST FILE A CLAIM WITHIN 60
DAYS AFTER THE SALE.
If you are a person with a disabili-
ty who needs any accommodation in
order to participate in this proceed-
ing, you are entitled, at no cost to you,
to the provision of certain assistance.
Please contact the Public Information
Dept., Pasco County Government Cen-
ter, 7530 Little Rd., New Port Richey,
FL 34654; (727) 847-8110 (V) in New
Port Richey; (352) 521-4274, ext 8110
(V) in Dade City, at least 7 days before
your scheduled court appearance, or
immediately upon receiving this notifi-
cation if the time before the scheduled
appearance is less than 7 days; if you
are hearing impaired call 711. The court
does not provide transportation and
cannot accommodate for this service.
Persons with disabilities needing trans-
portation to court should contact their
local public transportation providers
for information regarding transporta-
tion services.
Dated this 14 day of July, 2016.
By: Aamir Saeed, Esq.
Bar Number: 102826
Submitted by:
Choice Legal Group, P.A.
P.O. Box 9908
Fort Lauderdale, FL 33310-0908
Telephone: (954) 453-0365
Facsimile: (954) 771-6052
Toll Free: 1-800-441-2438
DESIGNATED PRIMARY E-MAIL
FOR SERVICE PURSUANT TO FLA.
R. JUD. ADMIN 2.516
eservice@clelegalgroup.com
15-01091
July 22, 29, 2016 16-02080P

FIRST INSERTION

NOTICE OF SALE
IN THE COUNTY COURT OF THE
SIXTH JUDICIAL CIRCUIT OF
FLORIDA IN AND FOR PASCO
COUNTY, FLORIDA
CIVIL DIVISION

**CASE NO. 2016-CC-0750-U
BRIAR PATCH VILLAGE OF
SEVEN SPRINGS HOMEOWNERS
ASSOCIATION, INC., a Florida
not-for-profit corporation,
Plaintiff, vs.
THE ESTATE OF CEASAR A.
CASTRO, ANY UNKNOWN HEIRS
AND BENEFICIARIES, FLORIDA
GOVERNMENTAL UTILITY
AUTHORITY and ANY UNKNOWN
OCCUPANTS IN POSSESSION,
Defendants.**

NOTICE IS HEREBY GIVEN that, pursuant to the Summary Final Judgment in this cause, in the County Court of Pasco County, Florida, I will sell all the property situated in Pasco County, Florida described as:

LOT 65, BRIAR PATCH VILLAGE OF SEVEN SPRINGS, PHASE 1, ACCORDING TO THE PLAT THEREOF AS RECORDED IN PLAT BOOK 40, PAGES 79-83, OF THE PUBLIC RECORDS OF PASCO COUNTY, FLORIDA. WITH THE FOLLOWING STREET ADDRESS: 2652 TOTTENHAM DRIVE, NEW PORT RICHEY, FLORIDA, 34655.

at public sale, to the highest and best bidder, for cash, at www.pasco.realforeclose.com, at 11:00 A.M. on August 22, 2016.

Any person claiming an interest in the surplus from the sale, if any, other than the property owner as of the date of the lis pendens must file a claim within 60 days after the sale.

If you are a person with a disability who needs any accommodation in order to participate in this proceeding, you are entitled, at no cost to you, to the provision of certain assistance. Please contact the Public Information Dept., Pasco County Government Center, 7530 Little Rd., New Port Richey, FL 34654; (727) 847-8110 (V) in New Port Richey; (352) 521-4274, ext 8110 (V) in Dade City, at least 7 days before your scheduled court appearance, or immediately upon receiving this notification if the time before the scheduled appearance is less than 7 days; if you are hearing impaired call 711. The court does not provide transportation and cannot accommodate for this service. Persons with disabilities needing transportation to court should contact their local public transportation providers for information regarding transportation services.

Dated this 14th day of July, 2016.

PAULA S. O'NEIL
CLERK OF THE CIRCUIT COURT
Joseph R. Cianfrone
(Joe@attorneyjoe.com)
Bar Number 248525

Attorney for Plaintiff Briar Patch Village of Seven Springs Village Homeowners Association, Inc. 1964 Bayshore Boulevard, Suite A Dunedin, Florida 34698 Telephone: (727) 738-1100 July 22, 29, 2016 16-02081P

FIRST INSERTION

NOTICE OF SALE
IN THE CIRCUIT COURT OF THE
SIXTH JUDICIAL CIRCUIT IN AND
FOR PASCO COUNTY FLORIDA

**CASE NO:
51-2013-CA-003457-CAAX-WS
INNOVA INVESTMENT GROUP,
LLC, and VIA LAM, LLC,
Plaintiff, vs.
BRYON WATSON, et al;
Defendants.**

NOTICE IS HEREBY GIVEN that pursuant to the Uniform Final Judgment of Foreclosure entered in the cause pending in the Circuit Court of the Sixth Judicial Circuit, in and for Pasco County, Florida, Case No: 2013-CA-003457-CAAX-WS, in which Innova Investment Group, LLC and Via Lam, LLC, is Plaintiff, and Bryon Watson; Carrie Watson; Unknown Tenant # 1; Unknown Tenant #2; are Defendants, the undersigned Clerk will sell the following described property situated in Pasco County, Florida:

LOT 117, COLONIAL MANOR 2, ACCORDING TO THE MAP OR PLAT THEREOF, AS RECORDED IN PLAT BOOK 8, PAGE(S) 30, OF THE PUBLIC RECORDS OF PASCO COUNTY, FLORIDA.
Property Address: 3642 Cantrell Street, New Port Richey, FL

Together with an undivided percentage interest in the common elements pertaining thereto at public sale, to the highest and best bidder for cash at 11:00 a.m. on the 18 day of August, 2016, in an online sale at www.pasco.realforeclose.com. Any person claiming

interest in the surplus from the sale, if any, other than the property owner as of the date of the Lis Pendens must file a claim within 60 days after the sale.

If you are a person with a disability who needs any accommodation in order to participate in this proceeding, you are entitled, at no cost to you, to the provision of certain assistance. Please contact the Public Information Dept., Pasco County Government Center, 7530 Little Rd., New Port Richey, FL 34654; (727) 847-8110 (V) in New Port Richey; (352) 521-4274, ext 8110 (V) in Dade City, at least 7 days before your scheduled court appearance, or immediately upon receiving this notification if the time before the scheduled appearance is less than 7 days; if you are hearing impaired call 711. The court does not provide transportation and cannot accommodate for this service. Persons with disabilities needing transportation to court should contact their local public transportation providers for information regarding transportation services

Dated this 14 day of July, 2016.

CAMERON H.P. WHITE
Florida Bar No. 021343
cwhite@southmilhausen.com
JASON R. HAWKINS
Florida Bar No. 011925
jhawkins@southmilhausen.com
South Milhausen, P.A.
1000 Legion Place, Suite 1200
Orlando, Florida 32801
Telephone: (407) 539-1638
Facsimile: (407) 539-2679
Attorneys for Plaintiff
July 22, 29, 2016 16-02087P

FIRST INSERTION

NOTICE OF FORECLOSURE SALE
IN THE CIRCUIT COURT OF
THE SIXTH JUDICIAL CIRCUIT
IN AND FOR PASCO COUNTY,
FLORIDA
GENERAL JURISDICTION
DIVISION

**Case No. 2015CA001605CAAXES
The Bank of New York Mellon fka
The Bank of New York as Trustee
for the Certificateholders of the
CWABS, Inc., Asset-Backed
Certificates, Series 2005-10,
Plaintiff, vs.
John Sepulveda, et al,
Defendants.**

NOTICE IS HEREBY GIVEN pursuant to a Final Judgment of Foreclosure dated June 29, 2016, entered in Case No. 2015CA001605CAAXES of the Circuit Court of the Sixth Judicial Circuit, in and for Pasco County, Florida, wherein The Bank of New York Mellon fka The Bank of New York as Trustee for the Certificateholders of the CWABS, Inc., Asset-Backed Certificates, Series 2005-10 is the Plaintiff and John Sepulveda; Olga Sepulveda; Suncoast Pointe Homeowners Association, Inc.; Heartwood 47, LLC are the Defendants, that Paula O'Neil, Pasco County Clerk of Court will sell to the highest and best bidder for cash by electronic sale at www.pasco.realforeclose.com, beginning at 11:00 AM on the 23rd day of August, 2016, the following described property as set forth in said Final Judgment, to wit:

LOT 20, BLOCK 6, SUNCOAST POINTE VILLAGES 1A AND 1B, AS PER PLAT THEREOF, RECORDED IN PLAT BOOK

48, PAGE 68 THROUGH 71, OF THE PUBLIC RECORDS OF PASCO COUNTY, FLORIDA.

Any person claiming an interest in the surplus from the sale, if any, other than the property owner as of the date of the lis pendens must file a claim within 60 days after the sale.

If you are a person with a disability who needs any accommodation in order to participate in this proceeding, you are entitled, at no cost to you, to the provision of certain assistance. Please contact the Public Information Dept., Pasco County Government Center, 7530 Little Rd., New Port Richey, FL 34654; (727) 847-8110 (V) in New Port Richey; (352) 521-4274, ext 8110 (V) in Dade City, at least 7 days before your scheduled court appearance, or immediately upon receiving this notification if the time before the scheduled appearance is less than 7 days; if you are hearing impaired call 711. The court does not provide transportation and cannot accommodate for this service. Persons with disabilities needing transportation to court should contact their local public transportation providers for information regarding transportation services.

By Jimmy Edwards, Esq.
Florida Bar No. 81855

BROCK & SCOTT, PLLC
Attorney for Plaintiff
1501 N.W. 49th Street, Suite 200
Pt. Lauderdale, FL 33309
Phone: (954) 618-6955, ext. 6209
Fax: (954) 618-6954
FLCourtDocs@brockandscott.com
File # 15-F00325
July 22, 29, 2016 16-02099P

FIRST INSERTION

NOTICE OF FORECLOSURE SALE
IN THE CIRCUIT COURT OF THE
6TH JUDICIAL CIRCUIT, IN AND
FOR PASCO COUNTY, FLORIDA
CIVIL DIVISION

**CASE NO.
2016CA000301CAAXWS
U.S. BANK NATIONAL
ASSOCIATION, AS TRUSTEE FOR
THE HOMEBANC MORTGAGE
TRUST 2005-1, MORTGAGE
BACKED NOTES
Plaintiff, vs.
WILLIAM J. FUNK; JANE E.
FUNK; WELLS FARGO BANK,
N.A. SUCCESSOR BY MERGER TO
WACHOVIA BANK, NATIONAL
ASSOCIATION; HUNTER'S RIDGE
HOMEOWNER'S ASSOCIATION,
INC.; UNKNOWN PERSON(S) IN
POSSESSION OF THE SUBJECT
PROPERTY;
Defendant(s)**

NOTICE IS HEREBY GIVEN pursuant to a Final Judgment of Foreclosure dated June 23, 2016, and entered in Case No. 2016CA000301CAAXWS, of the Circuit Court of the 6th Judicial Circuit in and for Pasco County, Florida, wherein U.S. BANK NATIONAL ASSOCIATION, AS TRUSTEE FOR THE HOMEBANC MORTGAGE TRUST 2005-1, MORTGAGE BACKED NOTES is Plaintiff and WILLIAM J. FUNK; JANE E. FUNK; UNKNOWN PERSON(S) IN POSSESSION OF THE SUBJECT PROPERTY; WELLS FARGO BANK, N.A. SUCCESSOR BY MERGER TO WACHOVIA BANK, NATIONAL ASSOCIATION; HUNTER'S RIDGE HOMEOWNER'S ASSOCIATION, INC.; are defendants. PAULA S. O'NEIL, the Clerk of the Circuit Court, will sell to the highest and best bidder for cash BY ELECTRONIC SALE AT: WWW.PASCO.REALFORECLOSE.COM, at 11:00 A.M., on the

17 day of August, 2016, the following described property as set forth in said Final Judgment, to wit:

LOT 381, HUNTER'S RIDGE UNIT THREE, ACCORDING TO THE PLAT THEREOF, AS RECORDED IN PLAT BOOK 26, PAGE(S) 120 - 121, OF THE PUBLIC RECORDS OF PASCO COUNTY, FLORIDA.

A person claiming an interest in the surplus from the sale, if any, other than the property owner as of the date of the lis pendens must file a claim within 60 days after the sale.

This notice is provided pursuant to Administrative Order 2010-045 PA/PI-CIR "If you are a person with disability who needs any accommodation in order to participate in this proceeding, you are entitled, at no cost to you the provision of certain assistance. Please contact Public Information Dept., Pasco County Government Center, 7530 Little Rd., New Port Richey, FL 34654; (727) 847-8110 (V) for proceedings in New Port Richey; (352) 521-4274, ext. 8110 (V) for proceedings in Dade City at least 7 days before your scheduled court appearance, or immediately upon receiving this notification if the time before the scheduled appearance is less than 7 days; if you are hearing or voice impaired, call 711."

Dated this 15 day of June, 2016

Eric M. Knopp, Esq.
Bar No.: 709921
Submitted by:
Kahane & Associates, P.A.
8201 Peters Road, Ste. 3000
Plantation, FL 33324
Telephone: (954) 382-3486
Telefacsimile: (954) 382-5380
Designated service email:
notice@kahaneandassociates.com
File No.: 15-03226 SPS
July 22, 29, 2016 16-02086P

FIRST INSERTION

RE-NOTICE OF
FORECLOSURE SALE
IN THE CIRCUIT COURT OF THE
6TH JUDICIAL CIRCUIT, IN AND
FOR PASCO COUNTY, FLORIDA
CIVIL DIVISION:

**CASE NO.:
51-2015-CA-002320-CAAX-WS
U.S. BANK NATIONAL
ASSOCIATION,
Plaintiff, vs.
DENISE M. ARNOLD AKA DENISE
M. TRETTEL; UNKNOWN SPOUSE
OF DENISE M. ARNOLD AKA
DENISE M. TRETTEL; BERTHE F.
KOEBERLE; UNKNOWN TENANT
#1; UNKNOWN TENANT #2,
Defendants.**

NOTICE IS HEREBY GIVEN pursuant to an Order Resetting Foreclosure Sale dated the 27th day of June 2016 and entered in Case No. 51-2015-CA-002320-CAAX-WS, of the Circuit Court of the 6TH Judicial Circuit in and for Pasco County, Florida, wherein U.S. BANK NATIONAL ASSOCIATION is the Plaintiff and DENISE M. ARNOLD A/K/A DENISE M. TRETTEL; BERTHE F. KOEBERLE; and UNKNOWN TENANT (S) IN POSSESSION OF THE SUBJECT PROPERTY are defendants. The Clerk of this Court shall sell to the highest and best bidder for cash, on the 18th day of August 2016 at 11:00 AM on Pasco County's Public Auction website: www.pasco.realforeclose.com, pursuant to judgment or order of the Court, in accordance with Chapter 45, Florida Statutes, the following described property as set forth in said Final Judgment, to wit:

LOTS 34, 35 AND 36, FOSSE HEIGHTS, ACCORDING TO THE MAP OR PLAT THEREOF, AS RECORDED IN PLAT BOOK 6, PAGE 62, OF THE PUBLIC RECORDS OF PASCO

COUNTY, FLORIDA
ANY PERSON CLAIMING AN INTEREST IN THE SURPLUS FROM THE SALE, IF ANY, OTHER THAN THE PROPERTY OWNER AS OF THE DATE OF THE LIS PENDENS MUST FILE A CLAIM WITHIN 60 DAYS AFTER THE SALE.

If you are a person with a disability who needs any accommodation in order to participate in this proceeding, you are entitled, at no cost to you, to the provision of certain assistance. Please contact the Public Information Dept., Pasco County Government Center, 7530 Little Rd., New Port Richey, FL 34654; (727) 847-8110 (V) in New Port Richey; (352) 521-4274, ext 8110 (V) in Dade City, at least 7 days before your scheduled court appearance, or immediately upon receiving this notification if the time before the scheduled appearance is less than 7 days; if you are hearing impaired call 711. The court does not provide transportation and cannot accommodate for this service. Persons with disabilities needing transportation to court should contact their local public transportation providers for information regarding transportation services.

Dated this 18 day of July, 2016.

By: Shane Fuller, Esq.
Bar Number: 100230
Submitted by:
Choice Legal Group, P.A.
P.O. Box 9908
Fort Lauderdale, FL 33310-0908
Telephone: (954) 453-0365
Facsimile: (954) 771-6052
Toll Free: 1-800-441-2438
DESIGNATED PRIMARY E-MAIL
FOR SERVICE PURSUANT TO FLA.
R. JUD. ADMIN 2.516
eservice@legalgroup.com
16-00782
July 22, 29, 2016 16-02105P

FIRST INSERTION

NOTICE OF ACTION
FORECLOSURE
PROCEEDINGS-PROPERTY
IN THE CIRCUIT COURT OF THE
SIXTH JUDICIAL CIRCUIT OF
FLORIDA, IN AND FOR PASCO
COUNTY

**Case #:
51-2016-CA-001984-ES/J4
Federal National Mortgage
Association ("Fannie Mae"), a
corporation organized and existing
under the laws of the United States
of America
Plaintiff, vs.-
Abel M. Cubero, Jr.
Defendant(s).**

TO: Unknown Heirs, Devisees, Grantees, Assignees, Creditors and Lienors of Dolores Cubero, and All Other Persons Claiming by and Through, Under, Against The Named Defendant (s), Whose Last Known Address is: ADDRESS UNKNOWN
Residence unknown, if living, including any unknown spouse of the said Defendants, if either has remarried and if either or both of said Defendants are dead, their respective unknown heirs, devisees, grantees, assignees, creditors, lienors, and trustees, and all other persons claiming by, through, under or against the named Defendant(s); and the aforementioned named Defendant(s) and such of the aforementioned unknown Defendants and such of the aforementioned unknown Defendants as may be infants, incompetents or otherwise not sui juris.

YOU ARE HEREBY NOTIFIED that an action has been commenced to foreclose a mortgage on the following real property, lying and being and situated in Pasco County, Florida, more particularly described as follows:

LOT 13, WILLOW BEND, UNIT D-3, ACCORDING TO THE

MAP OR PLAT THEREOF, AS RECORDED IN PLAT BOOK 34, PAGES 103 THROUGH 110, INCLUSIVE, OF THE PUBLIC RECORDS OF PASCO COUNTY, FLORIDA.

This action has been filed against you and you are required to serve a copy of your written defense, if any, upon SHAPIRO, FISHMAN & GACHÉ, LLP, Attorneys for Plaintiff, whose address is 4630 Woodland Corporate Blvd., Suite 100, Tampa, FL 33614 within thirty (30) days after the first publication of this notice and file the original with the clerk of this Court either before service on Plaintiff's attorney or immediately thereafter; otherwise a default will be entered against you for the relief demanded in the Complaint.

If you are a person with a disability who needs any accommodation in order to participate in this proceeding, you are entitled, at no cost to you, to the provision of certain assistance. Please contact the ADA Coordinator; 14250 49th Street North, Clearwater, Florida 33762 (727) 453-7163 at least 7 days before your scheduled court appearance, or immediately upon receiving this notification if the time before the scheduled appearance is less than 7 days. If you are hearing or voice impaired, call 711.

WITNESS my hand and seal of this Court on the 18th day of July, 2016.

Paula S. O'Neil, Ph.D.,
Clerk & Comptroller
Clerk of Circuit Court
By: Gerald Salgado
Deputy Clerk

SHAPIRO, FISHMAN & GACHÉ, LLP
Attorneys for Plaintiff
4630 Woodland Corporate Blvd.,
Suite 100
Tampa, FL 33614
14-279776
July 22, 29, 2016 16-02125P

FIRST INSERTION

NOTICE OF SALE
PURSUANT TO CHAPTER 45
IN THE CIRCUIT COURT OF THE
SIXTH JUDICIAL CIRCUIT IN AND
FOR PASCO COUNTY, FLORIDA
CIVIL ACTION

**CASE NO.:
2013CA000590CAAXWS
U.S. BANK NATIONAL
ASSOCIATION,
Plaintiff, vs.
STUMP, ANNA et al,
Defendant(s).**

NOTICE IS HEREBY GIVEN Pursuant to a Final Judgment of Foreclosure dated 14 April, 2016, and entered in Case No. 2013CA000590CAAXWS of the Circuit Court of the Sixth Judicial Circuit in and for Pasco County, Florida in which U.S. Bank National Association, is the Plaintiff and Donald L. Stump, Unknown Spouse of Donald L. Stump, Anna M. Stump, Unknown Spouse of Anna M. Stump, Sun Trust Bank, Beacon Woods Civic Association, Inc. Homeowners Association, And Any and All Unknown Parties Claiming By, Through, Under, and Against The Herein Named Individual Defendant(s) Who Are Not Known to be Dead or Alive, Whether Said Unknown Parties May Claim an Interest in Spouses, Heirs, Devisees, Grantees, or Other Claimants, are defendants, the Pasco County Clerk of the Circuit Court will sell to the highest and best bidder for cash in/on held online www.pasco.realforeclose.com: in Pasco County, Florida, Pasco County, Florida at 11:00 AM on the 15th of August, 2016, the following described property as set forth in said Final Judgment of Foreclosure:

LOT 22 GOLF CLUB VILLAGE BEACON WOODS VILLAGE 12B ACCORDING TO THE MAP OR PLAT THEREOF AS RECORDED IN PLAT BOOK 25 PAGES 133 THROUGH 135 OF THE

PUBLIC RECORDS OF PASCO COUNTY FLORIDA
8142 GOLF CLUB CT, BAYONET POINT, FL 34667

Any person claiming an interest in the surplus from the sale, if any, other than the property owner as of the date of the Lis Pendens must file a claim within 60 days after the sale.

If you are a person with a disability who needs an accommodation in order to participate in this proceeding, you are entitled, at no cost to you, to the provision of certain assistance. Please contact:

Public Information Dept., Pasco County Government Center, 7530 Little Rd., New Port Richey, FL 34654 Phone: 727.847.8110 (voice) in New Port Richey or 352.521.4274, ext 8110 (voice) in Dade City or 711 for the hearing impaired.

Contact should be initiated at least seven days before the scheduled court appearance, or immediately upon receiving this notification if the time before the scheduled appearance is less than seven days.

The court does not provide transportation and cannot accommodate such requests. Persons with disabilities needing transportation to court should contact their local public transportation providers for information regarding transportation services.

Dated in Hillsborough County, Florida this 13th day of July, 2016.

Nataija Brown, Esq.
FL Bar # 119491
Albertelli Law
Attorney for Plaintiff
P.O. Box 23028
Tampa, FL 33623
(813) 221-4743
(813) 221-9171 facsimile
eService: servealaw@albertelli.com
JR- 15-199599
July 22, 29, 2016 16-02079P

FIRST INSERTION

RE-NOTICE OF
FORECLOSURE SALE
IN THE CIRCUIT COURT OF THE
SIXTH JUDICIAL CIRCUIT, IN AND
FOR PASCO COUNTY, FLORIDA
CIVIL ACTION

**CASE NO.
51-2014-CA-003822-CAAX-ES
U.S. BANK NATIONAL
ASSOCIATION, AS TRUSTEE
FOR RESIDENTIAL FUNDING
MORTGAGE SECURITIES I, INC.,
MORTGAGE PASS-THROUGH
CERTIFICATES, SERIES 2007-56,
Plaintiff, vs.
JASON D. ALVIS, ET AL.
Defendants**

NOTICE IS HEREBY GIVEN pursuant to a Final Judgment of Foreclosure dated December 16, 2015, and entered in Case No. 51-2014-CA-003822-CAAX-ES, of the Circuit Court of the Sixth Judicial Circuit in and for Pasco County, Florida. U.S. BANK NATIONAL ASSOCIATION, AS TRUSTEE FOR RESIDENTIAL FUNDING MORTGAGE SECURITIES I, INC., MORTGAGE PASS-THROUGH CERTIFICATES, SERIES 2007-56 (hereafter "Plaintiff"), is Plaintiff and JASON D. ALVIS; KRISTIE L. ALVIS; THE INDEPENDENT SAVINGS PLAN COMPANY D/B/A ISPC; LEXINGTON OAKS OF PASCO COUNTY HOMEOWNERS ASSOCIATION, INC.; HOUSEHOLD FINANCE CORPORATION, III; UNITED STATES OF AMERICA, DEPARTMENT OF TREASURY-INTERNAL REVENUE SERVICE, are defendants. Paula S. O'Neil, Clerk of Court for PASCO, County Florida will sell to the highest and best bidder for cash via the Internet at www.pasco.realforeclose.com, at 11:00 a.m., on the 17th day of AUGUST, 2016, the following described property as set forth in said Final Judgment, to wit:

LOT 44, BLOCK 8, LEXING-

TON OAKS VILLAGE 8 AND VILLAGE 9, ACCORDING TO THE PLAT THEREOF IN PLAT BOOK 39, PAGES 73 THROUGH 76, INCLUSIVE, OF THE PUBLIC RECORDS OF PASCO COUNTY, FLORIDA.

Any person claiming an interest in the surplus from the sale, if any, other than the property owner as of the date of the Lis Pendens must file a claim within 60 days after the sale.

If you are a person with a disability who needs an accommodation in order to participate in this proceeding, you are entitled, at no cost to you, to the provision of certain assistance. Please contact: Public Information Dept., Pasco County Government Center, 7530 Little Rd., New Port Richey, FL 34654; Phone: 727.847.8110 (voice) in New Port Richey, 352.521.4274, ext 8110 (voice) in Dade City, Or 711 for the hearing impaired. Contact should be initiated at least seven days before the scheduled court appearance, or immediately upon receiving this notification if the time before the scheduled appearance is less than seven days. The court does not provide transportation and cannot accommodate such requests. Persons with disabilities needing transportation to court should contact their local public transportation providers for information regarding transportation services.

Morgan E. Long, Esq.
Florida Bar #: 99026
Email: MLong@vanlawfl.com
VAN NESS LAW FIRM, PLC
1239 E. Newport Center Drive,
Suite 110
Deerfield Beach, Florida 33442
Ph: (954) 571-2031
PRIMARY EMAIL:
Pleadings@vanlawfl.com
OC4918-13LP/to
July 22, 29, 2016 16-02096P

FIRST INSERTION

NOTICE OF ACTION
IN THE CIRCUIT COURT OF THE
SIXTH JUDICIAL CIRCUIT IN AND
FOR PASCO COUNTY, FLORIDA
CIVIL ACTION

**2016CA000943CAAXES/J4
WELLS FARGO BANK N.A.,
Plaintiff, vs.
UNKNOWN HEIRS,
BENEFICIARIES, DEVISEES,
SURVIVING SPOUSE, GRANTEEES,
ASSIGNEE, LIENORS,
CREDITORS, TRUSTEES, AND
ALL OTHER PARTIES CLAIMING
AN INTEREST BY THROUGH
UNDER OR AGAINST THE
ESTATE OF MARIA JAIME,
DECEASED; et al.,
Defendant(s).**

TO: Unknown Heirs, Beneficiaries, Devisees, Surviving Spouse, Grantees, Assignee, Lienors, Creditors, Trustee, and all Other Parties Claiming and Interest By Through Under or Against the Estate of Maria Jaime, Deceased Unknown Heirs, Beneficiaries, Devisees, Surviving Spouse, Grantees, Assignee, Lienors, Creditors, Trustee, and all Other Parties Claiming and Interest By Through Under or Against the Estate of Manuel Jaime, Deceased Last Known Residence: UNKNOWN

YOU ARE HEREBY NOTIFIED that an action to foreclose a mortgage on the following property in PASCO County, Florida:

LOT(S) 84, BLOCK 1 OF MEADOW POINTE PARCEL 9, UNIT 2 AS RECORDED IN PLAT BOOK 34, PAGE 132-136, ET SEQ., OF THE PUBLIC RECORDS OF PASCO COUNTY, FLORIDA
has been filed against you and you are required to serve a copy of your written defenses, if any, to it on ALDRIDGE | PITE, LLP, Plaintiff's attorney, at 1615

South Congress Avenue, Suite 200, Delray Beach, FL 33445 (Phone Number: (561) 392-6391), within 30 days of the first date of publication of this notice, and file the original with the clerk of this court either before AUG 22 2016 on Plaintiff's attorney or immediately thereafter; otherwise a default will be entered against you for the relief demanded in the complaint or petition.

If you are a person with a disability who needs any accommodation in order to participate in this proceeding, you are entitled, at no cost to you, to the provision of certain assistance. Please contact the Public Information Dept., Pasco County Government Center, 7530 Little Rd., New Port Richey, FL 34654; (727) 847-8110 (V) in New Port Richey; (352) 521-4274, ext 8110 (V) in Dade City, at least 7 days before your scheduled court appearance, or immediately upon receiving this notification if the time before the scheduled appearance is less than 7 days; if you are hearing impaired call 711. The court does not provide transportation and cannot accommodate for this service. Persons with disabilities needing transportation to court should contact their local public transportation providers for information regarding transportation services.

Dated on July 14, 2016.

Paula S. O'Neil, Ph.D.,
Clerk & Comptroller
As Clerk of the Court
By: Geraldo Salgado
As Deputy Clerk

ALDRIDGE | PITE, LLP
Plaintiff's attorney
1615 South Congress Avenue,
Suite 200
Delray Beach, FL 33445
(Phone Number: (561) 392-6391)
1113-752318B
July 22, 29, 2016 16-02117P

FIRST INSERTION

NOTICE OF FORECLOSURE SALE IN THE CIRCUIT COURT OF THE SIXTH JUDICIAL CIRCUIT IN AND FOR PASCO COUNTY, FLORIDA
GENERAL JURISDICTION DIVISION
Case No.

51-2012-CA-005556-WS
Ocwen Loan Servicing, LLC, Plaintiff, vs. Joseph Crocitto; Cypress Lakes Homeowners' Association, Inc.; et al. Defendants.

NOTICE IS HEREBY GIVEN pursuant to an Order dated June 15, 2016, entered in Case No. 51-2012-CA-005556-WS of the Circuit Court of the Sixth Judicial Circuit, in and for Pasco County, Florida, wherein Ocwen Loan Servicing, LLC is the Plaintiff and Joseph Crocitto; Cypress Lakes Homeowners' Association, Inc.; Cypress Lakes Homeowners' Association of Pasco, Inc.; Unknown Tenant #1; Unknown Tenant #2 are the Defendants, that Paula O'Neil, Pasco County Clerk of Court will sell to the highest and best bidder for cash by electronic sale at www.pasco.realforeclose.com, beginning at 11:00 AM on the 8th day of August, 2016, the following described property as set forth in said Final Judgment, to wit:

LOT 120, CYPRESS LAKES UNIT 3, PHASE 1, ACCORDING TO THE PLAT THEREOF, RECORDED IN PLAT BOOK 30, PAGES 59 THROUGH 61, INCLUSIVE, OF THE PUBLIC RECORDS OF PASCO COUNTY, FLORIDA.

TY, FLORIDA.

Any person claiming an interest in the surplus from the sale, if any, other than the property owner as of the date of the lis pendens must file a claim within 60 days after the sale.

If you are a person with a disability who needs any accommodation in order to participate in this proceeding, you are entitled, at no cost to you, to the provision of certain assistance. Please contact the Public Information Dept., Pasco County Government Center, 7530 Little Rd., New Port Richey, FL 34654; (727) 847-8110 (V) in New Port Richey; (352) 521-4274, ext 8110 (V) in Dade City, at least 7 days before your scheduled court appearance, or immediately upon receiving this notification if the time before the scheduled appearance is less than 7 days; if you are hearing impaired call 711. The court does not provide transportation and cannot accommodate for this service. Persons with disabilities needing transportation to court should contact their local public transportation providers for information regarding transportation services.

Dated this 19 day of July, 2016.
By Kathleen McCarthy, Esq., Florida Bar No. 72161

BROCK & SCOTT, PLLC
Attorney for Plaintiff
1501 N.W. 49th Street, Suite 200
Ft. Lauderdale, FL 33309
Phone: (954) 618-6955, ext. 6177
Fax: (954) 618-6954
FLCourtDocs@brockandscott.com
File # 14-F00815
July 22, 29, 2016 16-02130P

FIRST INSERTION

NOTICE OF FORECLOSURE SALE IN THE CIRCUIT COURT OF THE SIXTH JUDICIAL CIRCUIT OF FLORIDA IN AND FOR PASCO COUNTY
GENERAL JURISDICTION DIVISION
CASE NO.

51-2011-CA-000650WS
CU MEMBERS MORTGAGE, A DIVISION OF COLONIAL SAVINGS, F.A., Plaintiff, vs. ROBERT A ALLEN, ET AL., Defendants.

NOTICE IS HEREBY GIVEN pursuant to a Summary Final Judgment of Foreclosure entered April 1, 2016 in Civil Case No. 51-2011-CA-000650WS of the Circuit Court of the SIXTH Judicial Circuit in and for Pasco County, Dade City, Florida, wherein CU MEMBERS MORTGAGE, A DIVISION OF COLONIAL SAVINGS, F.A. is Plaintiff and ROBERT A ALLEN, ET AL., are Defendants, the Clerk of Court will sell to the highest and best bidder for cash electronically at www.pasco.realforeclose.com in accordance with Chapter 45, Florida Statutes on the 17TH day of August, 2016 at 11:00 AM on the following described property as set forth in said Summary Final Judgment, to wit:

Lot 10, Block 5, Magnolia Valley, Unit Three, according to the plat thereof, as recorded in Plat Book 9, Pages 150 and 151, of the Public Records of Pasco County, Florida.

Any person claiming an interest in the surplus from the sale, if any, other than the property owner as of the date of the lis pendens, must file a claim within 60 days after the sale.

If you are a person with a disability who needs any accommodation in order to participate in this proceeding, you are entitled, at no cost to you to the provision of certain assistance. Within two (2) working days of your receipt of this (describe notice/order) please contact the Public Information Dept., Pasco County Government Center, 7530 Little Rd., New Port Richey, FL 34654; (727) 847-8110 (V) in New Port Richey; (352) 521-4274, ext. 8110 (V) in Dade City; via 1-800-955-8771 if you are hearing impaired. The court does not provide transportation and cannot accommodate for this service. Persons with disabilities needing transportation to court should contact their local public transportation providers for information regarding disabled transportation services.

Lisa Woodburn, Esq.
Fla. Bar No.: 11003

McCalla Raymer Pierce, LLC
Attorney for Plaintiff
225 E. Robinson St.
Suite 155
Orlando, FL 32801
Phone: (407) 674-1850
Fax: (321) 248-0420
Email:
MRSservice@mccallaraymer.com
5056007
15-04955-3
July 22, 29, 2016 16-02129P

FIRST INSERTION

NOTICE OF FORECLOSURE SALE IN THE CIRCUIT COURT OF THE SIXTH JUDICIAL CIRCUIT, IN AND FOR PASCO COUNTY, FLORIDA
CIVIL DIVISION
CASE NO.:

2015CA002102CAAXWS
SANTANDER BANK, N.A. F/K/A SOVEREIGN BANK, N.A. F/K/A SOVEREIGN BANK Plaintiff, vs. EARLE HUSSEY A/K/A EARLE M. HUSSEY, et al Defendants.

NOTICE IS HEREBY GIVEN pursuant to a Final Judgment of foreclosure dated June 23, 2016, and entered in Case No. 2015CA002102CAAXWS of the Circuit Court of the SIXTH Judicial Circuit in and for PASCO COUNTY, Florida, wherein SANTANDER BANK, N.A. F/K/A SOVEREIGN BANK, N.A. F/K/A SOVEREIGN BANK, is Plaintiff, and EARLE HUSSEY A/K/A EARLE M. HUSSEY, et al are Defendants, the clerk, Paula S. O'Neil, will sell to the highest and best bidder for cash, beginning at 11:00 AM www.pasco.realforeclose.com, in accordance with Chapter 45, Florida Statutes, on the 24 day of August, 2016, the following described property as set forth in said Final Judgment, to wit:

Lot 24, 4-Lakes Estates, according to the plat thereof, as recorded in Plat Book 5, Page 162 of the Public Records of Pasco County, Florida.
Any person claiming an interest in the surplus funds from the sale, if any, other

than the property owner as of the date of the lis pendens must file a claim within 60 days after the sale.

If you are a person with a disability who needs any accommodation to participate in this proceeding, you are entitled, at no cost to you, to the provision of certain assistance. Please contact the Public Information Dept., Pasco County Government Center, 7530 Little Rd., New Port Richey, FL 34654; (727) 847-8110 (V) in New Port Richey; (352) 521-4274, ext 8110 (V) in Dade City, at least 7 days before your scheduled court appearance, or immediately upon receiving this notification if the time before the scheduled appearance is less than seven (7) days; if you are hearing or voice impaired, call 711.

The court does not provide transportation and cannot accommodate for this service. Persons with disabilities needing transportation to court should contact their local public transportation providers for information regarding transportation services.

Dated: July 15, 2016

By: Heather J. Koch, Esq., Florida Bar No. 89107

Phelan Hallinan
Diamond & Jones, PLLC
Attorneys for Plaintiff
2727 West Cypress Creek Road
Ft. Lauderdale, FL 33309
Tel: 954-462-7000
Fax: 954-462-7001
Service by email:
FL.Service@PhelanHallinan.com
PH # 49432
July 22, 29, 2016 16-02090P

FIRST INSERTION

NOTICE OF FORECLOSURE SALE IN THE CIRCUIT COURT OF THE SIXTH JUDICIAL CIRCUIT, IN AND FOR PASCO COUNTY, FLORIDA
CIVIL DIVISION
CASE NO.:

2015CA002571CAAXWS
BANK OF AMERICA, N.A., SUCCESSOR BY MERGER TO BAC HOME LOANS SERVICING, LP Plaintiff, vs. THE UNKNOWN HEIRS OR BENEFICIARIES OF THE ESTATE OF TERRY LYNN FRAWLEY A/K/A TERRY L. CRUSE-FRAWLEY A/K/A TERRY LYNN CRUSE-FRAWLEY, DECEASED, et al Defendants.

NOTICE IS HEREBY GIVEN pursuant to a Final Judgment of foreclosure dated June 30, 2016, and entered in Case No. 2015CA002571CAAXWS of the Circuit Court of the SIXTH Judicial Circuit in and for PASCO COUNTY, Florida, wherein BANK OF AMERICA, N.A., SUCCESSOR BY MERGER TO BAC HOME LOANS SERVICING, LP, is Plaintiff, and THE UNKNOWN HEIRS OR BENEFICIARIES OF THE ESTATE OF TERRY LYNN FRAWLEY A/K/A TERRY L. CRUSE-FRAWLEY A/K/A TERRY LYNN CRUSE-FRAWLEY, DECEASED, et al are Defendants, the clerk, Paula S. O'Neil, will sell to the highest and best bidder for cash, beginning at 11:00 AM www.pasco.realforeclose.com, in accordance with Chapter 45, Florida Statutes, on the 15 day of August, 2016, the following described property as set forth in said Final Judgment, to wit:

Lot 9, GRACEWOOD AT RIVER RIDGE, according to the plat thereof, as recorded in Plat Book

25, Page 75-77 of the Public Records of Pasco County, Florida.

Any person claiming an interest in the surplus funds from the sale, if any, other than the property owner as of the date of the lis pendens must file a claim within 60 days after the sale.

If you are a person with a disability who needs any accommodation to participate in this proceeding, you are entitled, at no cost to you, to the provision of certain assistance. Please contact the Public Information Dept., Pasco County Government Center, 7530 Little Rd., New Port Richey, FL 34654; (727) 847-8110 (V) in New Port Richey; (352) 521-4274, ext 8110 (V) in Dade City, at least 7 days before your scheduled court appearance, or immediately upon receiving this notification if the time before the scheduled appearance is less than seven (7) days; if you are hearing or voice impaired, call 711.

The court does not provide transportation and cannot accommodate for this service. Persons with disabilities needing transportation to court should contact their local public transportation providers for information regarding transportation services.

Dated: July 14, 2016
By: Heather J. Koch, Esq., Florida Bar No. 89107

Phelan Hallinan
Diamond & Jones, PLLC
Attorneys for Plaintiff
2727 West Cypress Creek Road
Ft. Lauderdale, FL 33309
Tel: 954-462-7000
Fax: 954-462-7001
Service by email:
FL.Service@PhelanHallinan.com
PH # 66733
July 22, 29, 2016 16-02083P

FIRST INSERTION

RE-NOTICE OF SALE PURSUANT TO CHAPTER 45 IN THE CIRCUIT COURT OF THE 6TH JUDICIAL CIRCUIT, IN AND FOR PASCO COUNTY, FLORIDA.
CASE NO.: 51-2008-CA-008127-ES

DEUTSCHE BANK NATIONAL TRUST COMPANY, AS TRUSTEE FOR AMERICAN HOME MORTGAGE ASSETS TRUST 2006-5, MORTGAGE-BACKED PASS-THROUGH CERTIFICATES SERIES 2006-5, Plaintiff, vs. IRENE T. POTTHAST, ET AL., Defendants.

NOTICE OF SALE IS HEREBY GIVEN pursuant to a Uniform Final Judgment of Foreclosure dated February 17 2016, and entered in Case No. 2008-CA-008127 of the Circuit Court of the 6th Judicial Circuit in and for Pasco County, Florida, wherein DEUTSCHE BANK NATIONAL TRUST COMPANY, AS TRUSTEE FOR AMERICAN HOME MORTGAGE ASSETS TRUST 2006-5, MORTGAGE-BACKED PASS-THROUGH CERTIFICATES SERIES 2006-5, is Plaintiff, and IRENE T. POTTHAST, ET AL., are the Defendants, the Office of Paula S. O'Neil, Pasco County Clerk of the Court will sell to the highest and best bidder for cash via online auction at www.pasco.realforeclose.com at 11:00 A.M. on the 16th day of August 2016, the following described property as set forth in said Final Judgment, to wit:

LOT 24, BLOCK 51, SEVEN OAKS PARCEL S-4A/S-4B/S-5B, ACCORDING TO THE MAP OR PLAT THEREOF AS RECORDED IN PLAT BOOK 51, PAGE 100, PUBLIC RECORDS OF PASCO COUNTY, FLORIDA.

FLORIDA.
Property Address: 3523 Hickory Hammock Loop Wesley Chapel FL 33543

and all fixtures and personal property located therein or thereon, which are included as security in Plaintiff's mortgage.

Any person claiming an interest in the surplus funds from the sale, if any, other than the property owner as of the date of the lis pendens must file a claim within 60 days after the sale.

If you are a person with a disability who needs any accommodation in order to participate in this proceeding, you are entitled, at no cost to you, to the provision of certain assistance. Please contact the Public Information Dept., Pasco County Government Center, 7530 Little Rd., New Port Richey, FL 34654; (727) 847-8110 (V) in New Port Richey; (352) 521-4274, ext 8110 (V) in Dade City, at least 7 days before your scheduled court appearance, or immediately upon receiving this notification if the time before the scheduled appearance is less than 7 days; if you are hearing impaired call 711. The court does not provide transportation and cannot accommodate for this service. Persons with disabilities needing transportation to court should contact their local public transportation providers for information regarding transportation services.

Dated this 18th day of July, 2016.

By: Jared Lindsey, Esq. FBN: 081974

Clarfield, Okon, Salomone & Pincus, P.L.
500 S. Australian Avenue, Suite 730
West Palm Beach, FL 33401
Telephone: (561) 713-1400
Facsimile: (561) 713-1401
Email: pleadings@copslaw.com
July 22, 29, 2016 16-02098P

FIRST INSERTION

NOTICE OF RESCHEDULED SALE IN THE CIRCUIT COURT OF THE SIXTH JUDICIAL CIRCUIT IN AND FOR PASCO COUNTY, FLORIDA
CIVIL ACTION
CASE NO.:

51-2008-CA-008002-ES
WACHOVIA MORTGAGE, FSB, F.K.A. WORLD SAVINGS BANK, Plaintiff, vs. SAYEF, MOHAMMAD et al, Defendant(s).

NOTICE IS HEREBY GIVEN Pursuant to an Order Rescheduling Foreclosure Sale dated June 10th, 2016, and entered in Case No. 51-2008-CA-008002-ES of the Circuit Court of the Sixth Judicial Circuit in and for Pasco County, Florida in which Wachovia Mortgage, FSB, f.k.a. World Savings Bank, is the Plaintiff and Mohammed Sayef, Sayida Bari, The Unknown Spouse of Mohammed Sayef, The Unknown Spouse of Sayida Bari, And Any and All Unknown Parties Claiming By, Through, Under, and Against The Herein Named Individual Defendant(s) Who Are Not Known to be Dead or Alive, Whether Said Unknown Parties May Claim an Interest in Spouses, Heirs, Devisees, Grantees, or Other Claimants, are defendants, the Pasco County Clerk of the Circuit Court will sell to the highest and best bidder for cash held online www.pasco.realforeclose.com in Pasco County, Florida, Pasco County, Florida at 11:00 AM on the 16th day of August, 2016, the following described property as set forth in said Final Judgment of Foreclosure:

LOT 3, BLOCK 32, LEXINGTON OAKS VILLAGE 32A AND VILLAGE 33, ACCORDING TO THE PLAT THEREOF AS RECORDED IN PLAT BOOK 40, PAGES 132 AND 133, OF THE PUBLIC RECORDS OF PASCO COUNTY, FLORIDA

5408 War Admiral Drive, Wesley Chapel, Florida 33544

Any person claiming an interest in the surplus from the sale, if any, other than the property owner as of the date of the Lis Pendens must file a claim within 60 days after the sale.

If you are a person with a disability who needs an accommodation in order to participate in this proceeding, you are entitled, at no cost to you, to the provision of certain assistance. Please contact: Public Information Dept., Pasco County Government Center, 7530 Little Rd., New Port Richey, FL 34654 Phone: 727.847.8110 (voice) in New Port Richey or 352.521.4274, ext 8110 (voice) in Dade City or 711 for the hearing impaired.

Contact should be initiated at least seven days before the scheduled court appearance, or immediately upon receiving this notification if the time before the scheduled appearance is less than seven days.

The court does not provide transportation and cannot accommodate such requests. Persons with disabilities needing transportation to court should contact their local public transportation providers for information regarding transportation services.

Dated in Hillsborough County, Florida, this 15th day of June, 2016.

David Osborne, Esq. Florida Bar # 70182

Albertelli Law
Attorney for Plaintiff
P.O. Box 23028
Tampa, FL 33623
(813) 221-4743
(813) 221-9171 facsimile
eService: servealaw@albertellilaw.com
AH-08-09298
July 22, 29, 2016 16-02103P

FIRST INSERTION

NOTICE OF FORECLOSURE SALE PURSUANT TO CHAPTER 45 IN THE CIRCUIT COURT OF THE SIXTH JUDICIAL CIRCUIT IN AND FOR PASCO COUNTY, FLORIDA
CASE NO.:

51-2012-CA-003769ES
WELLS FARGO BANK, NA, Plaintiff, vs. GEORGE BUDULANOVIC; ANNA SAKIBA BUDULANOVIC; et al., Defendant(s).

NOTICE IS HEREBY GIVEN that sale will be made pursuant to an Order or Final Judgment. Final Judgment was awarded on April 1, 2015 in Civil Case No. 51-2012-CA-003769ES, of the Circuit Court of the SIXTH Judicial Circuit in and for Pasco County, Florida, wherein, WELLS FARGO BANK, NA is the Plaintiff, and GEORGE BUDULANOVIC; ANNA SAKIBA BUDULANOVIC; UNKNOWN TENANT #1 N/K/A MICHAEL BUDULANOVIC; UNKNOWN TENANT #2 N/K/A ZINA BUDULANOVIC; PLANTATION PALMS HOMEOWNERS ASSOCIATION, INC.; SUNTRUST BANK; UNKNOWN TENANT #3 NKA LILJANA BUDULANOVIC; ANY AND ALL UNKNOWN PARTIES CLAIMING BY, THROUGH, UNDER AND AGAINST THE HEREIN NAMED INDIVIDUAL DEFENDANT(S) WHO ARE NOT KNOWN TO BE DEAD OR ALIVE, WHETHER SAID UNKNOWN PARTIES MAY CLAIM AN INTEREST AS SPOUSES, HEIRS, DEVISEES, GRANTEEES, OR OTHER CLAIMANTS are Defendants.

The clerk of the court, Paula O'Neil will sell to the highest bidder for cash www.pasco.realforeclose.com on August 9, 2016 at 11:00 AM; the following described real property as set forth in said Final Judgment, to wit:

LOT 593 OF PLANTATION PALMS, PHASE 5, ACCORDING TO THE PLAT THEREOF AS RECORDED

IN PLAT BOOK 47, PAGE(S) 133 THROUGH 136, OF THE PUBLIC RECORDS OF PASCO COUNTY, FLORIDA.

ANY PERSON CLAIMING AN INTEREST IN THE SURPLUS FROM THE SALE, IF ANY, OTHER THAN THE PROPERTY OWNER AS OF THE DATE OF THE LIS PENDENS MUST FILE A CLAIM WITHIN 60 DAYS AFTER THE SALE.

IMPORTANT AMERICANS WITH DISABILITIES ACT: If you are a person with a disability who needs an accommodation in order to participate in this proceeding, you are entitled, at no cost to you, to the provision of certain assistance. Please contact: Public Information Dept., Pasco County Government Center, 7530 Little Rd., New Port Richey, FL 34654; Phone: 727.847.8110 (voice) in New Port Richey, 352.521.4274, ext 8110 (voice) in Dade City, Or 711 for the hearing impaired. Contact should be initiated at least seven days before the scheduled court appearance, or immediately upon receiving this notification if the time before the scheduled appearance is less than seven days. The court does not provide transportation and cannot accommodate such requests. Persons with disabilities needing transportation to court should contact their local public transportation providers for information regarding transportation services.

Dated this 14 day of July, 2016.
By: Andrew Scolaro FBN 44927 for Susan W. Findley FBN: 160600

Primary E-Mail: ServiceMail@aldridgepите.com
ALDRIDGE | PITE, LLP
Attorney for Plaintiff
1615 South Congress Avenue
Suite 200
Delray Beach, FL 33445
Telephone: (844) 470-8804
Facsimile: (561) 392-6965
1175-967
July 22, 29, 2016 16-02077P

FIRST INSERTION

NOTICE OF FORECLOSURE SALE PURSUANT TO CHAPTER 45 IN THE CIRCUIT COURT OF THE SIXTH JUDICIAL CIRCUIT IN AND FOR PASCO COUNTY, FLORIDA
CASE NO.:

2015CA001852CAAXWS
HSBC BANK USA, NATIONAL ASSOCIATION AS TRUSTEE FOR J.P. MORGAN ALTERNATIVE LOAN TRUST 2006-A5 MORTGAGE PASS-THROUGH CERTIFICATES, Plaintiff, vs. KENNETH G DEMPSEY; et al., Defendant(s).

NOTICE IS HEREBY GIVEN that sale will be made pursuant to an Order or Final Judgment. Final Judgment was awarded on June 16, 2016 in Civil Case No. 2015CA001852CAAXWS, of the Circuit Court of the SIXTH Judicial Circuit in and for Pasco County, Florida, wherein, HSBC BANK USA, NATIONAL ASSOCIATION AS TRUSTEE FOR J.P. MORGAN ALTERNATIVE LOAN TRUST 2006-A5 MORTGAGE PASS-THROUGH CERTIFICATES is the Plaintiff, and KENNETH G DEMPSEY; MORTGAGE ELECTRONIC REGISTRATION SYSTEMS, INC., AS NOMINEE FOR GREENPOINT MORTGAGE FUNDING, INC ANY AND ALL UNKNOWN PARTIES CLAIMING BY, THROUGH, UNDER AND AGAINST THE HEREIN NAMED INDIVIDUAL DEFENDANT(S) WHO ARE NOT KNOWN TO BE DEAD OR ALIVE, WHETHER SAID UNKNOWN PARTIES MAY CLAIM AN INTEREST AS SPOUSES, HEIRS, DEVISEES, GRANTEEES, OR OTHER CLAIMANTS are Defendants.

The clerk of the court, Paula O'Neil, Ph.D. will sell to the highest bidder for cash at www.pasco.realforeclose.com on August 10, 2016 at 11:00 AM, the following described real property as set forth in said Final Judgment, to wit:

LOT 920, THE LAKES UNIT 5, ACCORDING TO THE MAP OR PLAT THEREOF, AS RE-

CORDED IN PLAT BOOK 18, PAGES 89 THROUGH 91, OF THE PUBLIC RECORDS OF PASCO COUNTY, FLORIDA.

ANY PERSON CLAIMING AN INTEREST IN THE SURPLUS FROM THE SALE, IF ANY, OTHER THAN THE PROPERTY OWNER AS OF THE DATE OF THE LIS PENDENS MUST FILE A CLAIM WITHIN 60 DAYS AFTER THE SALE.

IMPORTANT AMERICANS WITH DISABILITIES ACT: If you are a person with a disability who needs an accommodation in order to participate in this proceeding, you are entitled, at no cost to you, to the provision of certain assistance. Please contact: Public Information Dept., Pasco County Government Center, 7530 Little Rd., New Port Richey, FL 34654; Phone: 727.847.8110 (voice) in New Port Richey, 352.521.4274, ext 8110 (voice) in Dade City, Or 711 for the hearing impaired. Contact should be initiated at least seven days before the scheduled court appearance, or immediately upon receiving this notification if the time before the scheduled appearance is less than seven days. The court does not provide transportation and cannot accommodate such requests. Persons with disabilities needing transportation to court should contact their local public transportation providers for information regarding transportation services.

Dated this 15 day of July, 2016.
By: Susan Sparks - FBN 33626 for Susan W. Findley, Esq. FBN: 160600

Primary E-Mail: ServiceMail@aldridgepите.com
ALDRIDGE | PITE, LLP
Attorney for Plaintiff
1615 South Congress Avenue Suite 200
Delray Beach, FL 33445
Telephone: (844) 470-8804
Facsimile: (561) 392-6965
11221-11905B
July 22, 29, 2016 16-02094P

FIRST INSERTION

NOTICE OF ACTION IN THE CIRCUIT COURT OF THE SIXTH JUDICIAL CIRCUIT IN AND FOR PASCO COUNTY, FLORIDA
CIVIL ACTION
CASE NO.:

51-2016-CA-001071-ES/J4
U.S. BANK NATIONAL ASSOCIATION, AS TRUSTEE FOR LEHMAN XS TRUST MORTGAGE PASS-THROUGH CERTIFICATES, SERIES 2007-7N, Plaintiff, vs. YAK, LLC, et al, Defendant(s).

To: DIXIE D. WILLIAMS A/K/A DIXIE WILLIAMS
Last Known Address:
16650 Fairholt Way
Odessa, FL 33556
Current Address: Unknown
ANY AND ALL UNKNOWN PARTIES CLAIMING BY, THROUGH, UNDER, AND AGAINST THE HEREIN NAMED INDIVIDUAL DEFENDANT(S) WHO ARE NOT KNOWN TO BE DEAD OR ALIVE, WHETHER SAID UNKNOWN PARTIES MAY CLAIM AN INTEREST AS SPOUSES, HEIRS, DEVISEES, GRANTEEES, OR OTHER CLAIMANTS

Last Known Address: Unknown
Current Address: Unknown
YOU ARE NOTIFIED that an action to foreclose a mortgage on the following property in Pasco County, Florida:
LOT 16, COUNTRY WALK SUBDIVISION, INCREMENT B, PHASE 1, ACCORDING TO THE PLAT THEREOF RECORDED IN PLAT BOOK 55, PAGES 12-17, OF THE PUBLIC RECORDS OF PASCO COUNTY, FLORIDA.
A/K/A 4347 YANS CT, WESLEY CHAPEL, FL 33543
has been filed against you and you are required to serve a copy of your written defenses within 30 days after the first publication, if any, on Albertelli

Law, Plaintiff's attorney, whose address is P.O. Box 23028, Tampa, FL 33623, and file the original with this Court either before AUG 22 2016 service on Plaintiff's attorney, or immediately thereafter; otherwise, a default will be entered against you for the relief demanded in the Complaint or petition.

This notice shall be published once a week for two consecutive weeks in the Business Observer.
**See the Americans with Disabilities Act

If you are a person with a disability who needs an accommodation in order to participate in this proceeding, you are entitled, at no cost to you, to the provision of certain assistance. Please contact:

Public Information Dept., Pasco County Government Center, 7530 Little Rd., New Port Richey, FL 34654 Phone: 727.847.8110 (voice) in New Port Richey 352.521.4274, ext 8110 (voice) in Dade City or 711 for the hearing impaired.

Contact should be initiated at least seven days before the scheduled court appearance, or immediately upon receiving this notification if the time before the scheduled appearance is less than seven days.

The court does not provide transportation and cannot accommodate such requests. Persons with disabilities needing transportation to court should contact their local public transportation providers for information regarding transportation services.

WITNESS my hand and the seal of this court on this 15th day of July, 2016.
Paula S. O'Neil, Ph.D., Clerk & Comptroller
Clerk of the Circuit Court
By: Gerald Salgado Deputy Clerk

Albertelli Law
P.O. Box 23028
Tampa, FL 33623
EF - 15-205357
July 22, 29, 2016 16-02128P

FIRST INSERTION

NOTICE OF FORECLOSURE SALE PURSUANT TO CHAPTER 45 IN THE CIRCUIT COURT OF THE SIXTH JUDICIAL CIRCUIT IN AND FOR PASCO COUNTY, FLORIDA

CASE NO.: 2014-CA-000243-WS CITIBANK, N.A., NOT IN ITS INDIVIDUAL CAPACITY, BUT SOLELY AS TRUSTEE OF NRZ PASS-THROUGH TRUST VI, Plaintiff, vs.

DAVID E. KOLBAS; et al., Defendant(s).

NOTICE IS HEREBY GIVEN that sale will be made pursuant to an Order or Final Judgment. Final Judgment was awarded on June 16, 2016 in Civil Case No. 2014-CA-000243-WS, of the Circuit Court of the SIXTH Judicial Circuit in and for Pasco County, Florida, wherein, CITIBANK, N.A., NOT IN ITS INDIVIDUAL CAPACITY, BUT SOLELY AS TRUSTEE OF NRZ PASS-THROUGH TRUST VI is the Plaintiff, and DAVID E. KOLBAS; WILLIAM J. FETZNER; UNKNOWN TENANT 1 N/K/A MIKAEL ARDORINTANZA; CLERK OF THE CIRCUIT COURT IN AND FOR PASCO COUNTY; UNKNOWN SPOUSE OF WILLIAM J. FETZNER N/K/A AMY FETZNER; UNKNOWN TENANT 2 N/K/A DESTINY KEY; UNKNOWN SPOUSE OF DAVID E. KOLBAS N/K/A TINA KOLBAS;

ANY AND ALL UNKNOWN PARTIES CLAIMING BY, THROUGH, UNDER AND AGAINST THE HEREIN NAMED INDIVIDUAL DEFENDANT(S) WHO ARE NOT KNOWN TO BE DEAD OR ALIVE, WHETHER SAID UNKNOWN PARTIES MAY CLAIM AN INTEREST AS SPOUSES, HEIRS, DEVISEES, GRANTEES, OR OTHER CLAIMANTS are Defendants.

The clerk of the court, Paula O'Neil, Ph.D. will sell to the highest bidder for cash at www.pasco.realforeclose.com on August 10, 2016 at 11:00 AM, the following described real property as set forth in said Final Judgment, to wit:

LOT 93, JASMINE LAKES UNIT 2-A, ACCORDING TO THE MAP OR PLAT THEREOF AS RECORDED IN PLAT BOOK 7, PAGE 62, OF THE PUBLIC RECORDS OF PASCO COUNTY, FLORIDA.

ANY PERSON CLAIMING AN INTEREST IN THE SURPLUS FROM THE SALE, IF ANY, OTHER THAN THE PROPERTY OWNER AS OF THE DATE OF THE LIS PENDENS MUST FILE A CLAIM WITHIN 60 DAYS AFTER THE SALE.

IMPORTANT AMERICANS WITH DISABILITIES ACT: If you are a person with a disability who needs an accommodation in order to participate in this proceed-

ing, you are entitled, at no cost to you, to the provision of certain assistance. Please contact: Public Information Dept., Pasco County Government Center, 7530 Little Rd., New Port Richey, FL 34654; Phone: 727.847.8110 (voice) in New Port Richey, 352.521.4274, ext 8110 (voice) in Dade City, Or 711 for the hearing impaired. Contact should be initiated at least seven days before the scheduled court appearance, or immediately upon receiving this notification if the time before the scheduled appearance is less than seven days. The court does not provide transportation and cannot accommodate such requests. Persons with disabilities needing transportation to court should contact their local public transportation providers for information regarding transportation services.

Dated this 15 day of July, 2016.

By: Susan Sparks - FBN 33626 for Susan W. Findley, Esq. FBN: 160600

Primary E-Mail: ServiceMail@aldridgepите.com

ALDRIDGE | PITE, LLP Attorney for Plaintiff 1615 South Congress Avenue Suite 200

Delray Beach, FL 33445 Telephone: (844) 470-8804

Facsimile: (561) 392-6965 1092-7347B

July 22, 29, 2016 16-02095P

NOTICE OF SALE PURSUANT TO CHAPTER 45 IN THE CIRCUIT COURT OF THE SIXTH JUDICIAL CIRCUIT IN AND FOR PASCO COUNTY, FLORIDA

CIVIL ACTION CASE NO.: 51-2015-CA-003485-WS THE BANK OF NEW YORK MELLON FKA THE BANK OF NEW YORK, AS TRUSTEE FOR THE CERTIFICATEHOLDERS OF THE CWABS INC., ASSET-BACKED CERTIFICATES, SERIES 2006-26, Plaintiff, vs.

SISSON, SUSAN et al, Defendant(s).

NOTICE IS HEREBY GIVEN Pursuant to a Final Judgment of Foreclosure dated June 23rd, 2016, and entered in Case No. 51-2015-CA-003485-WS of the Circuit Court of the Sixth Judicial Circuit in and for Pasco County, Florida in which THE BANK OF NEW YORK MELLON FKA THE BANK OF NEW YORK, AS TRUSTEE FOR THE CERTIFICATEHOLDERS OF THE CWABS INC., ASSET-BACKED CERTIFICATES, SERIES 2006-26, is the Plaintiff and Beacon Woods Civic Association, Inc., Branch Banking and Trust Co., Susan K. Sisson a/k/a Susan Sisson, William W. Sisson a/k/a William Sisson, Any And All Unknown Parties Claiming by, Through, Un-

der, And Against The Herein named Individual Defendant(s) Who are not Known To Be Dead Or Alive, Whether Said Unknown Parties May Claim An Interest in Spouses, Heirs, Devisees, Grantees, Or Other Claimants, Unknown Party#1, Unknown Party#2, Unknown Party#3, Unknown Party#4, are defendants, the Pasco County Clerk of the Circuit Court will sell to the highest and best bidder for cash in/on held online www.pasco.realforeclose.com: in Pasco County, Florida, at 11:00 AM on the 17th day of August, 2016, the following described property as set forth in said Final Judgment of Foreclosure:

LOT 458, BEACON WOODS VILLAGE FOUR, ACCORDING TO THE PLAT THEREOF, RECORDED IN PLAT BOOK 11, PAGE(S) 63, 64 AND 65 OF THE PUBLIC RECORDS OF PASCO COUNTY, FLORIDA. 12506 Foxcroft Lane, Hudson, FL 34667

Any person claiming an interest in the surplus from the sale, if any, other than the property owner as of the date of the Lis Pendens must file a claim within 60 days after the sale.

If you are a person with a disability who needs an accommodation in order to participate in this proceeding, you are entitled, at no cost to you, to the provision of certain assistance. Please

contact: Public Information Dept., Pasco County Government Center, 7530 Little Rd., New Port Richey, FL 34654 Phone: 727.847.8110 (voice) in New Port Richey or 352.521.4274, ext 8110 (voice) in Dade City or 711 for the hearing impaired.

Contact should be initiated at least seven days before the scheduled court appearance, or immediately upon receiving this notification if the time before the scheduled appearance is less than seven days.

The court does not provide transportation and cannot accommodate such requests. Persons with disabilities needing transportation to court should contact their local public transportation providers for information regarding transportation services.

Dated in Hillsborough County, Florida, this 15th day of July, 2016.

Jennifer Komerak, Esq. FL Bar # 117796

Albertelli Law Attorney for Plaintiff P.O. Box 23028 Tampa, FL 33623 (813) 221-4743 (813) 221-9171 facsimile eService: servealaw@albertellilaw.com AH-15-175435

July 22, 29, 2016 16-02104P

FIRST INSERTION

NOTICE OF FORECLOSURE SALE IN THE CIRCUIT COURT OF THE SIXTH JUDICIAL CIRCUIT IN AND FOR PASCO COUNTY, FLORIDA

UCN: 512015CA002491CAAXWS CARRINGTON MORTGAGE SERVICES, LLC, Plaintiff, vs.

DAVID G MITCHELL, et al., Defendants.

NOTICE IS HEREBY GIVEN that pursuant the Final Judgment of Foreclosure dated July 6, 2015, and entered in Case No. 512015CA002491CAAXWS of the Circuit Court of the Sixth Judicial Circuit in and for Pasco County, Florida wherein CARRINGTON MORTGAGE SERVICES, LLC, is the Plaintiff and DAVID G MITCHELL, UNKNOWN SPOUSE OF DAVID G MITCHELL, STATE OF FLORIDA, PASCO COUNTY CLERK OF THE CIRCUIT COURT, UNKNOWN TENANT #1, UNKNOWN TENANT #2 are Defendants, Paula S. O'Neil, Ph.D., Clerk & Comptroller will sell to the highest and best bidder for cash www.pasco.realforeclose.com at 11:00 AM on the 22nd day of AUGUST, 2016, the following described property set forth in said Final Judgment, to wit:

LOT 1125, ALOHA GARDENS UNIT TEN, ACCORDING TO THE MAP OR PLAT THEREOF AS RECORDED IN PLAT BOOK 11, PAGE 80, PUBLIC RECORDS OF PASCO COUNTY, FLORIDA

Property Address: 3446 HOOVER DRIVE HOLIDAY, FL 34691

Any person or entity claiming an inter-

est in the surplus, if any, resulting from the Foreclosure Sale, other than the property owner as of the date of the Lis Pendens, must file a claim on same with the Clerk of Court within sixty (60) days after the Foreclosure Sale.

If you are a person with a disability who needs any accommodation in order to participate in this proceeding, you are entitled, at no cost to you, to the provision of certain assistance. Please contact the Public Information Dept., Pasco County Government Center, 7530 Little Rd., New Port Richey, FL 34654; (727) 847-8110 (V) in New Port Richey; (352) 521-4274, ext 8110 (V) in Dade City, at least 7 days before your scheduled court appearance, or immediately upon receiving this notification if the time before the scheduled appearance is less than 7 days; if you are hearing impaired call 711. The court does not provide transportation and cannot accommodate for this service. Persons with disabilities needing transportation to court should contact their local public transportation providers for information regarding transportation services.

DATED this, 14 day of July, 2016.

Morgan Swenk, Esq. Florida Bar No. 55454

Lender Legal Services, LLC 201 East Pine Street, Suite 730

Orlando, Florida 32801 Tel: (407) 730-4644

Fax: (888) 337-3815 Attorney for Plaintiff

Service Emails: MSwenk@LenderLegal.com

LLS@LenderLegal.com ELS04502

July 22, 29, 2016 16-02092P

NOTICE OF FORECLOSURE SALE IN THE CIRCUIT COURT OF THE SIXTH JUDICIAL CIRCUIT OF FLORIDA IN AND FOR PASCO COUNTY

GENERAL JURISDICTION DIVISION CASE NO.

51-2012-CA-007180-XXXX-ES DEUTSCHE BANK NATIONAL TRUST COMPANY AS TRUSTEE FOR HOLDERS OF THE HARBORVIEW 2006-5 TRUST, Plaintiff, vs.

EBONY WINDOM A/K/A EBONY BROWN WINDOM, ET AL., Defendants.

NOTICE IS HEREBY GIVEN pursuant to a Summary Final Judgment of Foreclosure entered June 3, 2016 in Civil Case No. 51-2012-CA-007180-XXXX-ES of the Circuit Court of the SIXTH Judicial Circuit in and for Pasco County, Dade City, Florida, wherein DEUTSCHE BANK NATIONAL TRUST COMPANY AS TRUSTEE FOR HOLDERS OF THE HARBORVIEW 2006-5 TRUST is Plaintiff and EBONY WINDOM A/K/A EBONY BROWN WINDOM, ET AL., are Defendants, the Clerk of Court will sell to the highest and best bidder for cash electronically at www.pasco.realforeclose.com in accordance with Chapter 45, Florida Statutes on the 15TH day of August, 2016 at 11:00 AM on the following described property as set forth in said Summary Final Judgment, to-wit:

Lot 6, Block 46, MEADOW POINTE IV PARCEL "J", according to the plat thereof, as recorded in Plat Book 53, Page 87,

of the Public Records of Pasco County, Florida.

Any person claiming an interest in the surplus from the sale, if any, other than the property owner as of the date of the lis pendens, must file a claim within 60 days after the sale.

If you are a person with a disability who needs any accommodation in order to participate in this proceeding, you are entitled, at no cost to you to the provision of certain assistance. Within two (2) working days of your receipt of this (describe notice/order) please contact the Public Information Dept., Pasco County Government Center, 7530 Little Rd., New Port Richey, FL 34654; (727) 847-8110 (V) in New Port Richey; (352) 521-4274, ext. 8110 (V) in Dade City; via 1-800-955-8771 if you are hearing impaired. The court does not provide transportation and cannot accommodate for this service. Persons with disabilities needing transportation to court should contact their local public transportation providers for information regarding disabled transportation services.

Lisa Woodburn, Esq. Fla. Bar No.: 11003

McCalla Raymer Pierce, LLC Attorney for Plaintiff

225 E. Robinson St. Suite 155

Orlando, FL 32801 Phone: (407) 674-1850

Fax: (321) 248-0420 Email: MRService@mccallaraymer.com

5049280 14-01858-3

July 22, 29, 2016 16-02084P

FIRST INSERTION

NOTICE OF ACTION IN THE CIRCUIT COURT OF THE SIXTH JUDICIAL CIRCUIT IN AND FOR PASCO COUNTY, FLORIDA

CIRCUIT CIVIL DIVISION CASE NO.: 2016CA001261CAAXWS WELLS FARGO BANK, N.A. Plaintiff, v.

THE UNKNOWN HEIRS OR BENEFICIARIES OF THE ESTATE OF DANIEL E. MCCARTHY A/K/A DANIEL EDWARD MCCARTHY A/K/A DANIEL MCCARTHY, DECEASED, et al Defendant(s).

TO: THE UNKNOWN HEIRS OR BENEFICIARIES OF THE ESTATE OF DANIEL E. MCCARTHY A/K/A DANIEL EDWARD MCCARTHY A/K/A DANIEL MCCARTHY, DECEASED; THERESA ANNE KRANKKA A/K/A TERRI ANNE MCCARTHY A/K/A THERESA AN MCCARTHY AND KEVIN ANTHONY MCCARTHY A/K/A KEVIN MCCARTHY

RESIDENT: Unknown

LAST KNOWN ADDRESS: 8441 NATIONAL DRIVE, PORT RICHEY, FL 34668-3333

TO: THERESA ANNE KRANKKA A/K/A TERRI ANNE MCCARTHY A/K/A THERESA AN MCCARTHY

RESIDENT: Unknown

LAST KNOWN ADDRESS: 603 HIGHFIELD DRIVE, SAINT CHARLES, MO 63304-7162

TO: KEVIN ANTHONY MCCARTHY A/K/A KEVIN MCCARTHY

RESIDENT: Unknown

LAST KNOWN ADDRESS: 1119 ERATO ST, APT 6, NEW ORLEANS, LA 70130-4200

YOU ARE HEREBY NOTIFIED that an action to foreclose a mortgage on the following described property located in Pasco County, Florida:

Lot 3, Block 6, JASMINE TRAILS, PHASE 2, according to the map or plat thereof, as recorded in Plat Book 25, Pages 109 through 111, Public Records of Pasco County, Florida.

has been filed against you, and you are required to serve a copy to your writ-

ten defenses, if any, to this action on Phelan Hallinan Diamond & Jones, PLLC, attorneys for plaintiff, whose address is 2727 West Cypress Creek Road, Ft. Lauderdale, FL 33309, and file the original with the Clerk of the Court, within 30 days after the first publication of this notice, either before or immediately thereafter, 8/22/16 otherwise a default may be entered against you for the relief demanded in the Complaint.

This notice shall be published once a week for two consecutive weeks in the Business Observer.

Movant counsel certifies that a bona fide effort to resolve this matter on the motion noticed has been made or that, because of time consideration, such effort has not yet been made but will be made prior to the scheduled hearing.

If you are a person with a disability who needs any accommodation to participate in this proceeding, you are entitled, at no cost to you, to the provision of certain assistance. Please contact the Public Information Dept., Pasco County Government Center, 7530 Little Rd., New Port Richey, FL 34654; (727) 847-8110 (V) in New Port Richey; (352) 521-4274, ext 8110 (V) in Dade City, at least 7 days before your scheduled court appearance, or immediately upon receiving this notification if the time before the scheduled appearance is less than seven (7) days; if you are hearing or voice impaired, call 711.

The court does not provide transportation and cannot accommodate for this service. Persons with disabilities needing transportation to court should contact their local public transportation providers for information regarding transportation services.

DATED: July 12, 2016

Paula S. O'Neil, Ph.D., Clerk & Comptroller By Carmella Hernandez Deputy Clerk of the Court

Phelan Hallinan Diamond & Jones, PLLC 2727 West Cypress Creek Road Ft. Lauderdale, FL 33309

PH # 71579

July 22, 29, 2016 16-02116P

NOTICE OF FORECLOSURE SALE IN THE CIRCUIT COURT OF THE SIXTH JUDICIAL CIRCUIT IN AND FOR PASCO COUNTY, FLORIDA

GENERAL JURISDICTION DIVISION Case No.

2015CA003909CAAXES Deutsche Bank National Trust Company as Trustee for IndyMac INDX Mortgage Loan Trust 2006-AR37, Mortgage Pass-Through Certificates Series 2006-AR37, Plaintiff, vs.

Ronald R. Radford, et al, Defendants.

NOTICE IS HEREBY GIVEN pursuant to a Final Judgment of Foreclosure dated June 29, 2016, entered in Case No. 2015CA003909CAAXES of the Circuit Court of the Sixth Judicial Circuit, in and for Pasco County, Florida, wherein Deutsche Bank National Trust Company as Trustee for IndyMac INDX Mortgage Loan Trust 2006-AR37, Mortgage Pass-Through Certificates Series 2006-AR37 is the Plaintiff and Ronald R. Radford; Robin M. Radford; Indian Lakes Property Association, Inc. are the Defendants, that Paula O'Neil, Pasco County Clerk of Court will sell to the highest and best bidder for cash by electronic sale at www.pasco.realforeclose.com, beginning at 11:00 AM on the 23rd day of August, 2016, the following described property as set forth in said Final Judgment, to wit:

LOT 82, INDIAN LAKES, ACCORDING TO THE PLAT THEREOF AS RECORDED

IN PLAT BOOK 41, PAGES 93 THROUGH 98 OF THE PUBLIC RECORDS OF PASCO COUNTY, FLORIDA.

Any person claiming an interest in the surplus from the sale, if any, other than the property owner as of the date of the lis pendens must file a claim within 60 days after the sale.

If you are a person with a disability who needs any accommodation in order to participate in this proceeding, you are entitled, at no cost to you, to the provision of certain assistance. Please contact the Public Information Dept., Pasco County Government Center, 7530 Little Rd., New Port Richey, FL 34654; (727) 847-8110 (V) in New Port Richey; (352) 521-4274, ext 8110 (V) in Dade City, at least 7 days before your scheduled court appearance, or immediately upon receiving this notification if the time before the scheduled appearance is less than 7 days; if you are hearing impaired call 711. The court does not provide transportation and cannot accommodate for this service. Persons with disabilities needing transportation to court should contact their local public transportation providers for information regarding transportation services.

By Jimmy Edwards, Esq. Florida Bar No. 81855

BROCK & SCOTT, PLLC Attorney for Plaintiff

1501 N.W. 49th Street, Suite 200 Ft. Lauderdale, FL 33309

Phone: (954) 618-6955, ext. 6209 Fax: (954) 618-6954

FLCourtDocs@brockandscott.com File # 14-F06966

July 22, 29, 2016 16-02100P

FIRST INSERTION

NOTICE OF SALE PURSUANT TO CHAPTER 45 IN THE CIRCUIT COURT OF THE 6TH JUDICIAL CIRCUIT IN AND FOR PASCO COUNTY, FLORIDA

CASE NO. 51-2015-CA-002246-WS U.S. BANK TRUST, N.A., AS TRUSTEE FOR LSF9 MASTER PARTICIPATION TRUST, Plaintiff, vs.

ROBERT LOCHEAD A/K/A ROBERT D. LOCHEAD A/K/A ROBERT DUNCAN LOCHEAD, ET AL., Defendants.

NOTICE OF SALE IS HEREBY GIVEN pursuant to a Uniform Final Judgment of Foreclosure dated June 30, 2016, and entered in Case No. 51-2015-CA-002246-WS of the Circuit Court of the 6th Judicial Circuit in and for Pasco County, Florida, wherein U.S. BANK TRUST, N.A., AS TRUSTEE FOR LSF9 MASTER PARTICIPATION TRUST, is Plaintiff, and ROBERT LOCHEAD A/K/A ROBERT D. LOCHEAD A/K/A ROBERT DUNCAN LOCHEAD, ET AL., are the Defendants, the Office of Paula S. O'Neil, Pasco County Clerk of the Court will sell to the highest and best bidder for cash via online auction at www.pasco.realforeclose.com at 11:00 A.M. on the 15th day of August, 2016, the following described property as set forth in said Final Judgment, to wit:

PARCEL 13 of the Unrecorded plat of FRANCES LANE is further described as follows: A portion of fractional Section 33, Township 24 South, Range 16 East, Pasco County, Florida, further described as follows: Commence at the NW corner of Lot 68 of SEA RANCH ON THE GULF, as shown on the plat recorded in Plat Book 4, Page 113 of the Public Records of Pasco County, Florida; Thence S 89°56'40" W., 295.00 feet; thence N 00°03'20" W., 160.00 feet for a Point of Beginning; thence continue N 00°03'20" W., 50.00 feet; thence N 89°56'40"

E., 147.50 feet; thence S 00°03'20" E., 50.00 feet; thence S 89°56'40" W., 147.50 feet to the Point of Beginning. The East 10 feet being reserved as road right of way and the West 5 feet of the East 15 feet being reserved as an utility easement and the West 37.5 feet being reserved for right of way purposes.

Property Address: 13527 Outboard Ct, Hudson, FL 34667 and all fixtures and personal property located therein or thereon, which are included as security in Plaintiff's mortgage.

Any person claiming an interest in the surplus funds from the sale, if any, other than the property owner as of the date of the lis pendens must file a claim within 60 days after the sale.

If you are a person with a disability who needs any accommodation in order to participate in this proceeding, you are entitled, at no cost to you, to the provision of certain assistance. Please contact the Public Information Dept., Pasco County Government Center, 7530 Little Rd., New Port Richey, FL 34654; (727) 847-8110 (V) in New Port Richey; (352) 521-4274, ext 8110 (V) in Dade City, at least 7 days before your scheduled court appearance, or immediately upon receiving this notification if the time before the scheduled appearance is less than 7 days; if you are hearing impaired call 711. The court does not provide transportation and cannot accommodate for this service. Persons with disabilities needing transportation to court should contact their local public transportation providers for information regarding transportation services.

Dated this 18th day of July, 2016.

By: Jared Lindsey, Esq. FBN: 081974

Clarfield, Okon, Salomone & Pincus, P.L.

500 S. Australian Avenue, Suite 730 West Palm Beach, FL 33401

Telephone: (561) 713-1400 Facsimile: (561) 713-1401

Email: pleadings@copslaw.com July 22, 29, 2016 16-02097P

FIRST INSERTION

NOTICE OF FORECLOSURE SALE IN THE CIRCUIT COURT OF THE SIXTH JUDICIAL CIRCUIT, IN AND FOR PASCO COUNTY, FLORIDA

CIVIL DIVISION CASE NO.: 2015CA003166CAAXWS BRANCH BANKING AND TRUST COMPANY Plaintiff, vs.

VINNY GALATI A/K/A VINCENZO F. GALATI, et al Defendants.

NOTICE IS HEREBY GIVEN pursuant to a Final Judgment of foreclosure dated June 30, 2016, and entered in Case No. 2015CA003166CAAXWS of the Circuit Court of the SIXTH Judicial Circuit in and for PASCO COUNTY, Florida, wherein BRANCH BANKING AND TRUST COMPANY, is Plaintiff, and VINNY GALATI A/K/A VINCENZO F. GALATI, et al are Defendants, the clerk, Paula S. O'Neil, will sell to the highest and best bidder for cash, beginning at 11:00 AM www.pasco.realforeclose.com, in accordance with Chapter 45, Florida Statutes, on the 18 day of August, 2016, the following described property as set forth in said Final Judgment, to wit:

THE EAST 125 FEET OF THE SOUTH 40 FEET OF LOT NINE (9), CITRUS TERRACE SUBDIVISION, SAID PORTION OF LOT AND SUBDIVISION BEING NUMBERED AND DESIGNATED IN ACCORDANCE WITH THE PLAT OF SAID SUBDIVISION AS THE SAME APPEAR OF RECORD IN PLAT BOOK 5 AT PAGE 155, PUBLIC RECORDS OF PASCO COUNTY, FLORIDA AND ALSO

THE WEST 25 FEET OF THE EAST 150 FEET OF THE SOUTH 40 FEET OF LOT NINE (9), CITRUS TERRACE AS SHOWN ON PLAT RECORDED IN PLAT BOOK 5, PAGE 155 OF THE PUBLIC RECORDS OF PASCO COUNTY FLORIDA AND ALSO

AN EASEMENT OVER THAT PORTION OF LOT NINE (9) OF CITRUS TERRACE AS SHOWN ON THE PLAT RECORDED IN PLAT BOOK 5, PAGE 155 OF THE PUBLIC RECORDS OF PASCO COUNTY FLORIDA LYING EAST OF THE SOUTHERLY EXTENSION OF THE EAST LINE OF LOT TEN (10) OF SAID CITRUS TERRACE, LESS THE SOUTH 40 FEET THEREOF.

Any person claiming an interest in the surplus funds from the sale, if any, other than the property owner as of the date of the lis pendens must file a claim within 60 days after the sale.

If you are a person with a disability who needs any accommodation to participate in this proceeding, you are entitled, at no cost to you, to the provision of certain assistance. Please contact the Public Information Dept., Pasco County Government Center, 7530 Little Rd., New Port Richey, FL 34654; (727) 847-8110 (V) in New Port Richey; (352) 521-4274, ext 8110 (V) in Dade City, at least 7 days before your scheduled court appearance, or immediately upon receiving this notification if the time before the scheduled appearance is less than seven (7) days; if you are hearing or voice impaired, call 711.

The court does not provide transportation and cannot accommodate for this service. Persons with disabilities needing transportation to court should contact their local public transportation providers for information regarding transportation services.

Dated: July 14, 2016

By: Heather J. Koch, Esq., Florida Bar No. 89107

Phelan Hallinan Diamond & Jones, PLLC Attorneys for Plaintiff

2727 West Cypress Creek Road Ft. Lauderdale, FL 33309

Tel: 954-462-7000 Fax: 954-462-7001

FIRST INSERTION

NOTICE OF SALE IN THE CIRCUIT COURT OF THE SIXTH JUDICIAL CIRCUIT, IN AND FOR PASCO COUNTY, FLORIDA CIVIL DIVISION

Case No. 2010-CA-8028-WS
WELLS FARGO BANK N.A., AS TRUSTEE, FOR CARRINGTON MORTGAGE LOAN TRUST, SERIES 2006-NC4 ASSET-BACKED PASS-THROUGH CERTIFICATES; Plaintiff, vs- NICHOLAS MOUNDROS, ET AL; Defendants, NOTICE IS GIVEN that, in accordance with the Order to Reschedule Foreclosure Sale dated June 14, 2016, in the above-styled cause, The Clerk of Court will sell to the highest and best bidder for cash at www.pasco.realforeclose.com, on August 8, 2016 at 11:00 am the following described property:

LOT 133, TANGLEWOOD TERRACE UNIT ONE: SAID LOT AND SUBDIVISION BEING NUMBERED AND DESIGNATED IN ACCORDANCE WITH THE PLAT OF SAID SUBDIVISION AS THE SAME APPEARS OF RECORD IN PLAT BOOK 10, PAGES 124, 125 AND 126 OF THE PUBLIC RECORDS OF PASCO COUNTY, FLORIDA. Address: 5015 IDLEWILD STREET, NEW PORT RICHEY, FL 34653 ANY PERSON CLAIMING AN INTEREST IN THE SURPLUS FROM

THE SALE, IF ANY, OTHER THAN THE PROPERTY OWNER AS OF THE DATE OF THE LIS PENDENS MUST FILE A CLAIM WITHIN 60 DAYS AFTER THE SALE.

If you are a person with a disability who needs any accommodation in order to participate in this proceeding, you are entitled, at no cost to you, to the provision of certain assistance. Please contact the Public Information Dept., Pasco County Government Center, 7530 Little Rd., New Port Richey, FL 34654; (727) 847-8110 (V) in New Port Richey; (352) 521-4274, ext 8110 (V) in Dade City, at least 7 days before your scheduled court appearance, or immediately upon receiving this notification if the time before the scheduled appearance is less than 7 days; if you are hearing impaired call 711. The court does not provide transportation and cannot accommodate for this service. Persons with disabilities needing transportation to court should contact their local public transportation providers for information regarding transportation services.

WITNESS my hand on July 18, 2016

Keith Lehman, Esq. FBN. 85111
Attorneys for Plaintiff
Marinosci Law Group, P.C.
100 West Cypress Creek Road, Suite 1045
Fort Lauderdale, FL 33309
Phone: (954)-644-8704;
Fax (954) 772-9601
ServiceFL@mlg-defaultlaw.com
ServiceFL2@mlg-defaultlaw.com
10-06049FC-1
July 22, 29, 2016 16-02122P

FIRST INSERTION

NOTICE OF SALE IN THE CIRCUIT COURT OF THE SIXTH JUDICIAL CIRCUIT IN AND FOR PASCO COUNTY, FLORIDA CASE NO.

51-2014-CA-002879 ES
WELLS FARGO BANK, N.A. Plaintiff, v. CECILIA PENNISI A/K/A CECILIA F. PENNISI; CATHRINE SHOEMAKER F/K/A CATHRINE M. PENNISI INDIV AND AS PERSONAL REPRESENTATIVE OF THE ESTATE OF CECILIA PENNISI A/K/A CECILIA F. PENNISI; UNKNOWN SPOUSE OF CATHRINE SHOEMAKER F/K/A CATHRINE M. PENNISI; SEBASTIAN P. PENNISI; UNKNOWN SPOUSE OF CECILIA PENNISI; UNKNOWN TENANT 1; UNKNOWN TENANT 2; AND ALL UNKNOWN PARTIES CLAIMING BY, THROUGH, UNDER OR AGAINST THE ABOVE NAMED DEFENDANT(S), WHO (IS/ARE) NOT KNOWN TO BE DEAD OR ALIVE, WHETHER SAID UNKNOWN PARTIES CLAIM AS HEIRS, DEVISEES, GRANTEES, ASSIGNEES, LIENORS, CREDITORS, TRUSTEES, SPOUSES, OR OTHER CLAIMANTS; LAKE HERON HOMEOWNERS' ASSOCIATION, INC.; UNITED STATES OF AMERICA, DEPARTMENT OF HOUSING AND URBAN DEVELOPMENT Defendants.

Notice is hereby given that, pursuant to the In Rem Final Judgment of Foreclosure entered on June 15, 2016, in this cause, in the Circuit Court of Pasco

County, Florida, the office of Paula S. O'Neil - AES, Clerk of the Circuit Court, shall sell the property situated in Pasco County, Florida, described as:

LOT 10, LAKE HERON PHASE 1, ACCORDING TO THE PLAT THEREOF, AS RECORDED IN PLAT BOOK 30, PAGE 141, OF THE PUBLIC RECORDS OF PASCO COUNTY, FLORIDA. a/k/a 21331 AARON CT., LUTZ, FL 33549-8721

at public sale, to the highest and best bidder, for cash, online at www.pasco.realforeclose.com, on August 10, 2016 beginning at 11:00 AM.

If you are a person claiming a right to funds remaining after the sale, you must file a claim with the clerk no later than 60 days after the sale. If you fail to file a claim you will not be entitled to any remaining funds.

ANY PERSONS WITH A DISABILITY REQUIRING REASONABLE ACCOMMODATIONS SHOULD CALL NEW PORT RICHEY (813) 847-8110; DADE CITY (352) 521-4274 EXT 8110; TDD 1-800-955-8771 VIA FLORIDA RELAY SERVICE, NO LATER THAN SEVEN (7) DAYS PRIOR TO ANY PROCEEDING.

Dated at St. Petersburg, Florida, this 14th day of July, 2016.

By: DAVID REIDER BAR #95719
eXL Legal, PLLC
Designated Email Address: efling@exllegal.com
12425 28th Street North, Suite 200
St. Petersburg, FL 33716
Telephone No. (727) 536-4911
Attorney for the Plaintiff
888140574
July 22, 29, 2016 16-02085P

FIRST INSERTION

NOTICE OF FORECLOSURE SALE IN THE CIRCUIT COURT OF THE SIXTH JUDICIAL CIRCUIT IN AND FOR PASCO COUNTY, FLORIDA GENERAL JURISDICTION DIVISION

Case No. 51-2014-CA-003357-CAAX-WS
Ventures Trust 2013-I-H-R by MCM Capital Partners, LLC, its trustee, Plaintiff, vs. Regina M. Carnell a/k/a Regina M. Allen a/k/a Regina M. Staples, et al, Defendants.

NOTICE IS HEREBY GIVEN pursuant to a Final Judgment of Foreclosure dated June 22, 2016, entered in Case No. 51-2014-CA-003357-CAAX-WS of the Circuit Court of the Sixth Judicial Circuit, in and for Pasco County, Florida, wherein Ventures Trust 2013-I-H-R by MCM Capital Partners, LLC, its trustee is the Plaintiff and Regina M. Carnell a/k/a Regina M. Allen a/k/a Regina M. Staples; Villas of Holiday Homeowners Association, Inc.; Board of County Commissioners of Pasco County, Florida; The Unknown Spouse of Regina M. Carnell a/k/a Regina M. Allen a/k/a Regina M. Staples; Any and All Unknown Parties Claiming By, Through, Under or Against the Herein Named Individual Defendant(s) who are not known to be dead or Alive, Whether said Unknown Parties may Claim an interest as Spouses, Heirs, Devisees, Grantees, of Other Claimants; Unknown Tenant(s) whose name is fictitious to account for parties in possession are the Defendants, that Paula O'Neil, Pasco County Clerk of Court will sell to the highest and best bidder for cash by electronic sale at www.pasco.realforeclose.com, beginning at 11:00 AM on the 11th day of August, 2016, the following described property as set forth in said Final Judgment

ment, to wit:

LOT 61, LESS THE SOUTH 0.7 FEET THEREOF, TOGETHER WITH THE SOUTH 0.7 FEET OF LOT 62, PINWOOD VILLAS, PHASE II, ACCORDING TO THE PLAT THEREOF RECORDED IN PLAT BOOK 18, PAGE 101, PUBLIC RECORDS OF PASCO COUNTY, FLORIDA.

Any person claiming an interest in the surplus from the sale, if any, other than the property owner as of the date of the lis pendens must file a claim within 60 days after the sale.

If you are a person with a disability who needs any accommodation in order to participate in this proceeding, you are entitled, at no cost to you, to the provision of certain assistance. Please contact the Public Information Dept., Pasco County Government Center, 7530 Little Rd., New Port Richey, FL 34654; (727) 847-8110 (V) in New Port Richey; (352) 521-4274, ext 8110 (V) in Dade City, at least 7 days before your scheduled court appearance, or immediately upon receiving this notification if the time before the scheduled appearance is less than 7 days; if you are hearing impaired call 711. The court does not provide transportation and cannot accommodate for this service. Persons with disabilities needing transportation to court should contact their local public transportation providers for information regarding transportation services.

By Jimmy Edwards, Esq. Florida Bar No. 81855
BROCK & SCOTT, PLLC
Attorney for Plaintiff
1501 N.W. 49th Street, Suite 200
Ft. Lauderdale, FL 33309
Phone: (954) 618-6955, ext. 6209
Fax: (954) 618-6954
FLCourtDocs@brockandscott.com
File # 15-F00980
July 22, 29, 2016 16-02102P

FIRST INSERTION

NOTICE OF ACTION IN THE CIRCUIT COURT OF THE SIXTH JUDICIAL CIRCUIT IN AND FOR PASCO COUNTY, FLORIDA CASE NO.:

2015CA002555CAAXWS
GREEN TREE SERVICING, LLC, Plaintiff, vs. UNKNOWN HEIRS, BENEFICIARIES, DEVISEES AND ALL OTHER PARTIES CLAIMING AN INTEREST BY, THROUGH, UNDER OF THE ESTATE OF GLORIA ORTIZ AKA GLORIA M. ORTIZ, DECEASED; et al., Defendant(s).

TO: Unknown Heirs, Beneficiaries, Devisees and All Other Parties Claiming an Interest By, Through, Under of the Estate of Gloria Ortiz aka Gloria M. Ortiz, Deceased
Last Known Residence: UNKNOWN
YOU ARE HEREBY NOTIFIED that an action to foreclose a mortgage on the following property in Pasco County, Florida:

LOT 1087, THE LAKES UNIT SIX, ACCORDING TO THE PLAT THEREOF, AS RECORDED IN PLAT BOOK 20, PAGES 129 THROUGH 131, INCLUSIVE, OF THE PUBLIC RECORDS OF PASCO COUNTY, FLORIDA.

has been filed against you and you are required to serve a copy of your written defenses, if any, to it on ALDRIDGE | PITE, LLP, Plaintiff's attorney, at 1615 South Congress Avenue, Suite 200, Delray Beach, FL 33445 (Phone Number: (561) 392-6391), within 30 days of the first date of publication of this

notice, and file the original with the clerk of this court either before 8/22/16 on Plaintiff's attorney or immediately thereafter; otherwise a default will be entered against you for the relief demanded in the complaint or petition.

If you are a person with a disability who needs any accommodation in order to participate in this proceeding, you are entitled, at no cost to you, to the provision of certain assistance. Please contact the Public Information Dept., Pasco County Government Center, 7530 Little Rd., New Port Richey, FL 34654; (727) 847-8110 (V) in New Port Richey; (352) 521-4274, ext 8110 (V) in Dade City, at least 7 days before your scheduled court appearance, or immediately upon receiving this notification if the time before the scheduled appearance is less than 7 days; if you are hearing impaired call 711. The court does not provide transportation and cannot accommodate for this service. Persons with disabilities needing transportation to court should contact their local public transportation providers for information regarding transportation services.

Dated on July 12, 2016.

Paula S. O'Neil, Ph.D., Clerk & Comptroller
By: Carmella Hernandez As Deputy Clerk
ALDRIDGE | PITE, LLP
Plaintiff's attorney
1615 South Congress Avenue, Suite 200
Delray Beach, FL 33445
(Phone Number: (561) 392-6391)
1382-662B
July 22, 29, 2016 16-02118P

FIRST INSERTION

NOTICE OF ACTION IN THE CIRCUIT COURT OF THE SIXTH JUDICIAL CIRCUIT, IN AND FOR PASCO COUNTY, FLORIDA.

CASE NO.: 2015CA002214
HSBC BANK USA, NATIONAL ASSOCIATION, AS INDENTURE TRUSTEE FOR THE REGISTERED NOTEHOLDERS OF RENAISSANCE HOME EQUITY LOAN TRUST 2006-4, Plaintiff, vs.

Estate of Esther Titus; The unknown spouse, heirs, beneficiaries, devisees, grantees, assignees, lienors, creditors, trustees and all other parties claiming an interest by, through, under or against the Estate of Esther Titus; Unknown Tenant #1; Unknown Tenant #2; Defendants.

TO: Diane Furguson
Residence Unknown
If living; if dead, all unknown parties claiming interest by, through, under or against the above named defendant(s), whether said unknown parties claim as heirs, devisees, grantees, creditors, or other claimants; and all parties having or claiming to have any right, title or interest in the property herein described.
YOU ARE NOTIFIED that an action to foreclose a mortgage on the following described property in Pasco County, Florida:

Lot 5, Casson Heights, according to the plat thereof, recorded in Plat Book 4, Page 95, Public Records of Pasco County, Florida. Street Address: 6027 Antrim St, New Port Richey, Florida 34653 *on or before 8/22/16

has been filed against you and you are required to serve a copy of your written

defenses, if any, to it on Clarfield, Okon, Salomone & Pincus, P.L., Plaintiff's attorney, whose address is 500 Australian Avenue South, Suite 730, West Palm Beach, FL 33401, within 30 days after the date of the first publication of this notice and file the original with the Clerk of this Court, otherwise, a default will be entered against you for the relief demanded in the complaint or petition.

If you are a person with a disability who needs any accommodation in order to participate in this proceeding, you are entitled, at no cost to you, to the provision of certain assistance. Please contact the Public Information Dept., Pasco County Government Center, 7530 Little Rd., New Port Richey, FL 34654; (727) 847-8110 (V) in New Port Richey; (352) 521-4274, ext 8110 (V) in Dade City, at least 7 days before your scheduled court appearance, or immediately upon receiving this notification if the time before the scheduled appearance is less than 7 days; if you are hearing impaired call 711. The court does not provide transportation and cannot accommodate for this service. Persons with disabilities needing transportation to court should contact their local public transportation providers for information regarding transportation services.

DATED on 7/12, 2016.
Paula S. O'Neil, Ph.D., Clerk & Comptroller
By: Carmella Hernandez As Deputy Clerk

Clarfield, Okon, Salomone & Pincus, P.L., Attorney for Plaintiff
500 Australian Avenue South, Suite 730
West Palm Beach, FL 33401
Telephone: (561) 713-1400
July 22, 29, 2016 16-02119P

FIRST INSERTION

NOTICE OF SALE PURSUANT TO CHAPTER 45 IN THE CIRCUIT COURT OF THE SIXTH JUDICIAL CIRCUIT IN AND FOR PASCO COUNTY, FLORIDA CIVIL ACTION

CASE NO.: 51-2015-CA-003024-WS
DEUTSCHE BANK NATIONAL TRUST COMPANY, AS TRUSTEE, IN TRUST FOR REGISTERED HOLDERS OF LONG BEACH MORTGAGE LOAN TRUST 2006-6, ASSET-BACKED CERTIFICATES, SERIES 2006-6, Plaintiff, vs. MAKOWSKI, DOREEN et al, Defendant(s).

NOTICE IS HEREBY GIVEN Pursuant to a Final Judgment of Foreclosure dated June 23rd, 2016, and entered in Case No. 51-2015-CA-003024-WS of the Circuit Court of the Sixth Judicial Circuit in and for Pasco County, Florida in which Deutsche Bank National Trust Company, as Trustee, In trust for registered Holders of Long Beach Mortgage Loan Trust 2006-6, Asset-Backed Certificates, Series 2006-6, is the Plaintiff and Doreen Makowski, Any And All Unknown Parties Claiming by, Through, Under, And Against The Herein named Individual Defendant(s) Who are not Known To Be Dead Or Alive, Whether Said Unknown Parties May Claim An Interest in Spouses, Heirs, Devisees, Grantees, Or Other Claimants, are defendants, the Pasco County Clerk of the Circuit Court will sell to the highest and best bidder for cash in/on held online www.pasco.realforeclose.com: in Pasco County, Florida, Pasco County, Florida at 11:00 AM on the 17th day of August, 2016, the following described property as set forth in said Final Judgment of Foreclosure:

LOT 119, WEST PORT SUBDIVISION, UNIT SIX, AS PER PLAT RECORDED IN PLAT BOOK 16,

PAGES 124 AND 125, PUBLIC RECORDS OF PASCO COUNTY, FLORIDA.

9731 San Vicente Way, Port Richey, FL 34668
Any person claiming an interest in the surplus from the sale, if any, other than the property owner as of the date of the Lis Pendens must file a claim within 60 days after the sale.

If you are a person with a disability who needs an accommodation in order to participate in this proceeding, you are entitled, at no cost to you, to the provision of certain assistance. Please contact:

Public Information Dept., Pasco County Government Center, 7530 Little Rd., New Port Richey, FL 34654 Phone: 727.847.8110 (voice) in New Port Richey or 352.521.4274, ext 8110 (voice) in Dade City or 711 for the hearing impaired.

Contact should be initiated at least seven days before the scheduled court appearance, or immediately upon receiving this notification if the time before the scheduled appearance is less than seven days.

The court does not provide transportation and cannot accommodate such requests. Persons with disabilities needing transportation to court should contact their local public transportation providers for information regarding transportation services.

Dated in Hillsborough County, Florida, this 18th day of July 2016.

Grant Dostie, Esq. FL Bar # 119886
Albertelli Law
Attorney for Plaintiff
P.O. Box 23028
Tampa, FL 33623
(813) 221-4743
(813) 221-9171 facsimile
eService: servealaw@albertellilaw.com
AH-15-188427
July 22, 29, 2016 16-02111P

FIRST INSERTION

NOTICE OF ACTION IN THE CIRCUIT COURT OF THE SIXTH JUDICIAL CIRCUIT IN AND FOR PASCO COUNTY, FLORIDA CIVIL ACTION

CASE NO.: 51-2016-CA-001402WS
WELLS FARGO BANK, N.A., Plaintiff, vs. THE UNKNOWN HEIRS, DEVISEES, GRANTEES, ASSIGNEES, LIENORS, CREDITORS, TRUSTEES, OR OTHER CLAIMANTS CLAIMING BY, THROUGH, UNDER, OR AGAINST, OSCAR DELGADO A/K/A OSCAR DELGADO RAMOS A/K/A OSCAR DELGADO-RAMOS, DECEASED , et al, Defendant(s).

TO: THE UNKNOWN HEIRS, DEVISEES, GRANTEES, ASSIGNEES, LIENORS, CREDITORS, TRUSTEES, OR OTHER CLAIMANTS CLAIMING BY, THROUGH, UNDER, OR AGAINST, OSCAR DELGADO A/K/A OSCAR DELGADO RAMOS A/K/A OSCAR DELGADO-RAMOS, DECEASED

Last Known Address: Unknown
Current Address: Unknown

ANY AND ALL UNKNOWN PARTIES CLAIMING BY, THROUGH, UNDER, AND AGAINST THE HEREIN NAMED INDIVIDUAL DEFENDANT(S) WHO ARE NOT KNOWN TO BE DEAD OR ALIVE, WHETHER SAID UNKNOWN PARTIES MAY CLAIM AN INTEREST AS SPOUSES, HEIRS, DEVISEES, GRANTEES, OR OTHER CLAIMANTS

Last Known Address: Unknown
Current Address: Unknown

YOU ARE NOTIFIED that an action to foreclose a mortgage on the following property in Pasco County, Florida:

LOT 20 AND THE SOUTH 10 FEET OF LOT 19, COLONIAL HILLS, UNIT ONE, ACCORDING TO THE PLAT THEREOF AS RECORDED IN PLAT BOOK 9, PAGE 9, OF THE PUBLIC RECORDS OF PASCO COUNTY, FLORIDA. A/K/A 3507 COLONIAL HILLS

DR, NEW PORT RICHEY, FL 34652

has been filed against you and you are required to serve a copy of your written defenses within 30 days after the first publication, if any, on Albertelli Law, Plaintiff's attorney, whose address is P.O. Box 23028, Tampa, FL 33623, and file the original with this Court either before 8/22/16 service on Plaintiff's attorney, or immediately thereafter; otherwise, a default will be entered against you for the relief demanded in the Complaint or petition.

This notice shall be published once a week for two consecutive weeks in the Business Observer.

**See the Americans with Disabilities Act

If you are a person with a disability who needs an accommodation in order to participate in this proceeding, you are entitled, at no cost to you, to the provision of certain assistance. Please contact:

Public Information Dept., Pasco County Government Center, 7530 Little Rd., New Port Richey, FL 34654 Phone: 727.847.8110 (voice) in New Port Richey 352.521.4274, ext 8110 (voice) in Dade City or 711 for the hearing impaired.

Contact should be initiated at least seven days before the scheduled court appearance, or immediately upon receiving this notification if the time before the scheduled appearance is less than seven days.

The court does not provide transportation and cannot accommodate such requests. Persons with disabilities needing transportation to court should contact their local public transportation providers for information regarding transportation services.

WITNESS my hand and the seal of this court on this 12 day of July, 2016.

Paula S. O'Neil, Ph.D., Clerk & Comptroller
By: Carmella Hernandez Deputy Clerk

Albertelli Law
P.O. Box 23028
Tampa, FL 33623
EF - 16-003525
July 22, 29, 2016 16-02114P

FIRST INSERTION

RE-NOTICE OF FORECLOSURE SALE IN THE CIRCUIT COURT OF THE 6TH JUDICIAL CIRCUIT, IN AND FOR PASCO COUNTY, FLORIDA CIVIL DIVISION:

CASE NO.: 51-2014-CA-000364-ES - U.S. BANK NATIONAL ASSOCIATION, AS TRUSTEE, ON BEHALF OF THE HOLDERS OF THE STRUCTURED ASSET INVESTMENT LOAN TRUST MORTGAGE PASS-THROUGH CERTIFICATES, SERIES 2006-3, Plaintiff, vs.

BARBARA HUCKABAY A/K/A BARBARA LEE HUCKABAY AKA BARBARA L. HUCKABAY; WILLIAM D. HOLTZHOWER; SUMMER L. HOLTZHOWER; UNKNOWN SPOUSE OF BARBARA HUCKABAY A/K/A BARBARA LEE HUCKABAY A/K/A BARBARA L. HUCKABAY; UNKNOWN TENANT IN POSSESSION OF THE SUBJECT PROPERTY, Defendants.

NOTICE IS HEREBY GIVEN pursuant to an Order Resetting Foreclosure Sale dated the 16th day of June 2016 and entered in Case No. 51-2014-CA-000364-ES -, of the Circuit Court of the 6TH Judicial Circuit in and for Pasco County, Florida, wherein U.S. BANK NATIONAL ASSOCIATION, AS TRUSTEE, ON BEHALF OF THE HOLDERS OF THE STRUCTURED ASSET INVESTMENT LOAN TRUST MORTGAGE PASS-THROUGH CERTIFICATES, SERIES 2006-3 is the Plaintiff and BARBARA HUCKABAY A/K/A BARBARA LEE HUCKABAY AKA BARBARA L. HUCKABAY; WILLIAM D. HOLTZHOWER; SUMMER L. HOLTZHOWER; and UNKNOWN TENANT(S) IN POSSESSION OF THE SUBJECT PROPERTY are defendants. The Clerk of this Court shall sell to the highest and best bidder for cash, on the 22nd day of August 2016 at 11:00 AM on Pasco County's Public Auction website: www.pasco.realforeclose.com, pursuant to judgment or order of the Court, in accordance with

Chapter 45, Florida Statutes, the following described property as set forth in said Final Judgment, to wit:

THE SOUTH 308 FEET OF THE NORTH 333 FEET OF THE EAST 1/2 OF THE NORTHEAST 1/4 OF THE SOUTHWEST 1/4 OF THE SOUTHEAST 1/4 OF SECTION 28, TOWNSHIP 24 SOUTH, RANGE 21 EAST, PASCO COUNTY, FLORIDA.

ANY PERSON CLAIMING AN INTEREST IN THE SURPLUS FROM THE SALE, IF ANY, OTHER THAN THE PROPERTY OWNER AS OF THE DATE OF THE LIS PENDENS MUST FILE A CLAIM WITHIN 60 DAYS AFTER THE SALE.

If you are a person with a disability who needs any accommodation in order to participate in this proceeding, you are entitled, at no cost to you, to the provision of certain assistance. Please contact the Public Information Dept., Pasco County Government Center, 7530 Little Rd., New Port Richey, FL 34654; (727) 847-8110 (V) in New Port Richey; (352) 521-4274, ext 8110 (V) in Dade City, at least 7 days before your scheduled court appearance, or immediately upon receiving this notification if the time before the scheduled appearance is less than 7 days; if you are hearing impaired call 711. The court does not provide transportation and cannot accommodate for this service. Persons with disabilities needing transportation to court should contact their local public transportation providers for information regarding transportation services.

Dated this 19 day of July, 2016.
By: Richard Thomas Vendetti, Esq. Bar Number: 112255

Submitted by:
Choice Legal Group, P.A.
P.O. Box 9908
Fort Lauderdale, FL 33310-0908
Telephone: (954) 453-0365
Facsimile: (954) 771-6052
Toll Free: 1-800-441-2438
DESIGNATED PRIMARY E-MAIL FOR SERVICE PURSUANT TO FLA. R. JUD. ADMIN 2.516
eservice@legalgroup.com
12-09876
July 22, 29, 2016 16-02121P

OFFICIAL COURTHOUSE WEBSITES:

MANATEE COUNTY: manateeclerk.com | SARASOTA COUNTY: sarasotaclerk.com

CHARLOTTE COUNTY: charlotte.realforeclose.com | LEE COUNTY: leeclerk.org

COLLIER COUNTY: collierclerk.com | HILLSBOROUGH COUNTY: hillsclerk.com

PASCO COUNTY: pasco.realforeclose.com | PINELLAS COUNTY: pinellasclerk.org

POLK COUNTY: polkcountyclerk.net | ORANGE COUNTY: myorangeclerk.com

Check out your notices on:
www.floridapublicnotices.com

Business Observer

SUBSEQUENT INSERTIONS

SECOND INSERTION

NOTICE OF SALE
NOTICE IS HEREBY GIVEN that Gordon Harbaugh, d/b/a G's Performance Cycle, Inc. (Owner) shall sell certain property as per FS 83.806 described as that certain 1972 Triumph Chopper with the serial number of 52RT40203 and engine number C092017575 in the amount of \$98,022.00 incurred for storage and mechanic's work since January 24, 2004, AND that certain, 1965 Triumph 650 Tiger with serial number of T12ORDU15087 in the amount of \$110,628.00 incurred for storage and mechanic's work since February 7, 2002 at owner's storage facility at 4131 Louis Avenue #11, Holiday, FL 34691.(727)939-0880. Unless said claim is paid by July 1, 2016 said property will be advertised for sale and sold on August 1, 2016. The sale shall be conducted at 10:00 a.m. on that date at G's Performance Cycle, Inc., 4131 Louis Avenue #11, Holiday, FL 34691.

Larry Crow
Attorney for G. Harbaugh
1247 S. Pinellas Ave.
Tarpon Springs, FL 34689
Ph.: 727-945-1112
Fax: 727-945-9224
July 15, 22, 2016 16-02015P

THIRD INSERTION

NOTICE OF ACTION
STATE OF FLORIDA
FLORIDA BOARD OF
PROFESSIONAL ENGINEERS
FEMC Case No.: 2015023010
FLORIDA BOARD OF
PROFESSIONAL ENGINEERS,
Petitioner, vs.
DWR ARCHITECTURE AND
ENGINEERING, INC.,
Respondent

TO: DWR Architecture and Engineering, Inc.
7451 Osteen Road
New Port Richey, Florida 34653
UNLICENSED ACTIVITY
The Florida Board of Professional Engineers has filed an Administrative Complaint against you, a copy of which may be obtained by contacting, Rebecca Valentine, Legal Department, Florida Board of Professional Engineers, 2639 N. Monroe Street, Suite 112, Tallahassee, Florida 32303, (850) 521-0500 ext. 106.

If no contact has been made by you concerning the above by August 08, 2016, the matter of the Administrative Complaint will be presented at a hearing pursuant to 120.57(2), F.S. before the Florida Board of Professional Engineers.

In accordance with the Americans with Disabilities Act, persons needing a special accommodation to participate in this proceeding should contact the individual or agency sending notice not later than seven days prior to the proceeding at the address given on the notice. Telephone: (850) 257-6097; 1-800-955-8771 (TDD) or 1-800-955-8770 (v), via Florida Relay Service.

July 8, 15, 22, 29, 2016 16-01952P

SECOND INSERTION

NOTICE TO CREDITORS
IN THE CIRCUIT COURT OF THE
SIXTH JUDICIAL CIRCUIT IN AND
FOR PASCO COUNTY, FLORIDA
PROBATE DIVISION
Case No.: 51-2016-CP-000342-W.
In Re the Estate of
WILLIAM S. HOLUBIAK,
Deceased.

The administration of the estate of WILLIAM S. HOLUBIAK, deceased, whose date of death was November 3, 2015, is pending in the Circuit Court for Pasco County, Florida, Probate Division, the address of which is 7530 Little Road New Port Richey, Florida 34654. The names and addresses of the personal representative and the personal representative's attorney are set forth below.

All creditors of the decedent and other persons having claims or demands against decedent's estate on whom a copy of this notice is required to be served must file their claims with this court ON OR BEFORE THE LATER OF 3 MONTHS AFTER THE TIME OF THE FIRST PUBLICATION OF THIS NOTICE OR 30 DAYS AFTER THE DATE OF SERVICE OF A COPY OF THIS NOTICE ON THEM.

All other creditors of the decedent and other persons having claims or demands against decedent's estate must file their claims with this court WITHIN 3 MONTHS AFTER THE DATE OF THE FIRST PUBLICATION OF THIS NOTICE.

ALL CLAIMS NOT FILED WITHIN THE TIME PERIODS SET FORTH IN FLORIDA STATUTES SECTION 733.702 WILL BE FOREVER BARRED.

NOTWITHSTANDING THE TIME PERIODS SET FORTH ABOVE, ANY CLAIM FILED TWO (2) YEARS OR MORE AFTER THE DECEDENT'S DATE OF DEATH IS BARRED.

The date of first publication of this notice is July 15, 2016.

Personal Representative:
THOMAS M. HOLUBIAK
Attorney for Personal Representative:
Christopher W. Boss, Esq.
Florida Bar No. 13183
Boss Law
9887 4th Street North
St. Petersburg, Florida 33702
Phone: (727) 471-0039
Fax: (727) 471-1206
CWBSservice@protectyourfuture.com
July 15, 22, 2016 16-02012P

SECOND INSERTION

NOTICE TO CREDITORS
IN THE CIRCUIT COURT FOR
PASCO COUNTY, FLORIDA
PROBATE DIVISION
File No.
2016-CP-757
Division PROBATE
IN RE: ESTATE OF
RUTH B. NEWMAN
Deceased.

The administration of the estate of Ruth B. Newman, deceased, whose date of death was April 24, 2016, is pending in the Circuit Court for Pasco County, Florida, Probate Division, the address of which is 7530 Little Road, New Port Richey, Florida 34654. The names and addresses of the personal representative and the personal representative's attorney are set forth below.

All creditors of the decedent and other persons having claims or demands against decedent's estate on whom a copy of this notice is required to be served must file their claims with this court ON OR BEFORE THE LATER OF 3 MONTHS AFTER THE TIME OF THE FIRST PUBLICATION OF THIS NOTICE OR 30 DAYS AFTER THE DATE OF SERVICE OF A COPY OF THIS NOTICE ON THEM.

All other creditors of the decedent and other persons having claims or demands against decedent's estate must file their claims with this court WITHIN 3 MONTHS AFTER THE DATE OF THE FIRST PUBLICATION OF THIS NOTICE.

ALL CLAIMS NOT FILED WITHIN THE TIME PERIODS SET FORTH IN FLORIDA STATUTES SECTION 733.702 WILL BE FOREVER BARRED.

NOTWITHSTANDING THE TIME PERIODS SET FORTH ABOVE, ANY CLAIM FILED TWO (2) YEARS OR MORE AFTER THE DECEDENT'S DATE OF DEATH IS BARRED.

The date of first publication of this notice is July 15, 2016.

Personal Representative:
Arthur W. Galiardo, Jr.
4810 Dundee Dr.
Brandenton, Florida 34210
Attorney for Personal Representative:
Melanie DeLeon-Thompson, Esq.
Attorney
Florida Bar Number: 0091546
SCHOFIELD & SPENCER PA
1429 60th Avenue W,
Suite 300
Bradenton, FL 34207
Telephone: (941) 755-2674
Fax: (941) 756-0981
E-Mail: melanie@sspa.legal
Secondary E-Mail: grace@sspa.legal
July 15, 22, 2016 16-02003P

SECOND INSERTION

NOTICE OF FORECLOSURE SALE
IN THE CIRCUIT COURT
FOR THE SIXTH JUDICIAL
CIRCUIT IN AND FOR
PASCO COUNTY, FLORIDA
CIRCUIT CIVIL DIVISION
CASE No.:
2016CA000023CAAXES
CITIFINANCIAL SERVICES, INC.
3000 Bayport Drive, Suite 880
Tampa, FL 33607

Plaintiff, vs.
DELIA J. COX A/K/A DELIA J. BABCOCK; DAVID COX;
Defendant(s).
NOTICE IS HEREBY GIVEN THAT, pursuant to Plaintiff's Final Judgment of Foreclosure entered on June 29, 2016, in the above-captioned action, the Clerk of Court, Paula S. O'Neil, will sell to the highest and best bidder for cash at www.pasco.realforeclose.com in accordance with Chapter 45, Florida Statutes on the 23rd day of August, 2016, at 11:00 A.M. on the following described property as set forth in said Final Judgment of Foreclosure, to wit:

THE FOLLOWING DESCRIBED LOT, PIECE OR PARCEL OF LAND, SITUATE, LYING AND BEING IN THE COUNTY OF PASCO, STATE OF FLORIDA, TO WIT: COMMENCE AT THE NORTHWEST CORNER OF TRACT 20 IN SECTION 15, TOWNSHIP 26 SOUTH, RANGE 21 EAST, AS PER PLAT OF ZEPHYRHILLS COLONY COMPANY LANDS, AS FILED IN PLAT BOOK 1 PAGE 55, PUBLIC RECORDS OF PASCO COUNTY, FLORIDA, AND THENCE RUN SOUTH 130 FEET FOR POINT OF BEGINNING; THENCE RUN EAST 165 FEET, THENCE SOUTH 65 FEET, THENCE WEST 165 FEET, THENCE NORTH 65 FEET TO POINT OF BEGINNING; LESS AND EXCEPT ROAD RIGHT OF WAY. PROPERTY ADDRESS: 4824 LANE RD, ZEPHYRHILLS, FL 33541

Any person claiming an interest in the surplus from the sale, if any, other than the property owner as of

the date of the lis pendens, must file a claim within sixty (60) days after the sale.

Pursuant to the Fla. R. Jud. Admin. 2.516, the above signed counsel for Plaintiff designates attorney@padgetlaw.net as its primary e-mail address for service, in the above styled matter, of all pleadings and documents required to be served on the parties.

AMERICANS WITH DISABILITIES ACT: IF YOU ARE A PERSON WITH A DISABILITY WHO NEEDS AN ACCOMMODATION IN ORDER TO PARTICIPATE IN THIS PROCEEDING, YOU ARE ENTITLED, AT NO COST TO YOU, TO THE PROVISION OF CERTAIN ASSISTANCE. PLEASE CONTACT: PUBLIC INFORMATION DEPT., PASCO COUNTY GOVERNMENT CENTER, 7530 LITTLE RD., NEW PORT RICHEY, FL 34654; PHONE: (727)847-8110 (VOICE) IN NEW PORT RICHEY, (352)521-4274, EXT 8110 (VOICE) IN DADE CITY, OR 711 FOR THE HEARING IMPAIRED. CONTACT SHOULD BE INITIATED AT LEAST SEVEN DAYS BEFORE THE SCHEDULED COURT APPEARANCE, OR IMMEDIATELY UPON RECEIVING THIS NOTIFICATION IF THE TIME BEFORE THE SCHEDULED APPEARANCE IS LESS THAN SEVEN DAYS. THE COURT DOES NOT PROVIDE TRANSPORTATION AND CANNOT ACCOMMODATE SUCH REQUESTS. PERSONS WITH DISABILITIES NEEDING TRANSPORTATION TO COURT SHOULD CONTACT THEIR LOCAL PUBLIC TRANSPORTATION PROVIDERS FOR INFORMATION REGARDING TRANSPORTATION SERVICES.

Respectfully submitted,
HARRISON SMALBACH, ESQ.
Florida Bar # 116255
TIMOTHY D. PADGETT, P.A.
6267 Old Water Oak Road,
Suite 203
Tallahassee, FL 32312
(850) 422-2520 (telephone)
(850) 422-2567 (facsimile)
attorney@padgetlaw.net
Attorney for Plaintiff
TDP File No.
17002013-2701L-3
July 15, 22, 2016 16-01983P

SECOND INSERTION

NOTICE OF ACTION
IN THE CIRCUIT COURT
OF THE 6TH JUDICIAL
CIRCUIT, IN AND FOR
PASCO COUNTY,
FLORIDA.
CASE No.:
51-2012-CA-006384-WS J2
DEUTSCHE BANK NATIONAL
TRUST COMPANY, AS TRUSTEE
FOR GSAMP TRUST 2006-FM 2,
MORTGAGE PASS-THROUGH
CERTIFICATES, SERIES
2006-FM2,
Plaintiff, vs.
Christopher C. Cafaro; Unknown
Spouse of Christopher C. Cafaro;
Beacon Woods Civic Association,
Inc.; Unknown Tenant #1; Unknown
Tenant #2;
Defendants.

TO: Unknown Parties claiming by through, under or against the Estate of Christopher C. Cafaro, deceased, whether said Unknown Parties claim as spouses, heirs, devisees, grantees, assignees, lienors, creditors, trustees or other claimants, may have or claim some right, title or interest in the to the property sought to be foreclosed 8514 Lincolnshire Drive Hudson, FL 3466

If living: if dead, all unknown parties claiming interest by, through, under or against the above named defendant(s), whether said unknown parties claim as heirs, devisees, grantees, creditors, or other claimants; and all parties having or claiming to have any right, title or interest in the property herein described.

YOU ARE NOTIFIED that an action to foreclose a mortgage on the following described property in Pasco County, Florida:

Lot 2080, Beacon Woods Village 11-C, according to the plat thereof recorded in the Office of the Clerk of the Circuit Court, Pasco County, Florida, Plat Book 15, Pages 42-43-44.
Street Address: 8514 Lincolnshire Drive; Hudson, FL 34667
*on or before 8/15/16

has been filed against you and you are required to serve a copy of your writ-

ten defenses, if any, to it on Clarfield, Okon, Salomone & Pincus, P.L., Plaintiff's attorney, whose address is 500 Australian Avenue South, Suite 825, West Palm Beach, FL 33401, within 30 days after the date of the first publication of this notice and file the original with the Clerk of this Court, otherwise, a default will be entered against you for the relief demanded in the complaint or petition.

If you are a person with a disability who needs any accommodation in order to participate in this proceeding, you are entitled, at no cost to you, to the provision of certain assistance. Please contact the Public Information Dept., Pasco County Government Center, 7530 Little Rd., New Port Richey, FL 34654; (727) 847-8110 (V) in New Port Richey; (352) 521-4274, ext 8110 (V) in Dade City, at least 7 days before your scheduled court appearance, or immediately upon receiving this notification if the time before the scheduled appearance is less than 7 days; if you are hearing impaired call 711. The court does not provide transportation and cannot accommodate for this service. Persons with disabilities needing transportation to court should contact their local public transportation providers for information regarding transportation services.

DATED on July 5, 2016.
Paula S. O'Neil, Ph.D.,
Clerk & Comptroller
BY: Carmella Hernandez
As Deputy Clerk

Clarfield, Okon, Salomone & Pincus, P.L.,
Attorney for Plaintiff
500 Australian Avenue South,
Suite 825
West Palm Beach, FL 33401
Telephone: (561) 713-1400-
pleadings@cosplaw.com
July 15, 22, 2016 16-01987P

SECOND INSERTION

NOTICE TO CREDITORS
IN THE CIRCUIT COURT FOR
PASCO COUNTY, FLORIDA
PROBATE DIVISION
File No.
51-2016-CP-000784-CPAXWS
Division I
IN RE:
ESTATE OF
MARY CRAIB
Deceased.

The administration of the estate of MARY CRAIB, deceased, whose date of death was June 1, 2016, is pending in the Circuit Court for Pasco County, Florida, Probate Division, the address of which is PO Box 338, New Port Richey, Florida 34656-0338. The names and addresses of the personal representative and the personal representative's attorney are set forth below.

All creditors of the decedent and other persons having claims or demands against decedent's estate on whom a copy of this notice is required to be served must file their claims with this court ON OR BEFORE THE LATER OF 3 MONTHS AFTER THE TIME OF THE FIRST PUBLICATION OF THIS NOTICE OR 30 DAYS AFTER THE DATE OF SERVICE OF A COPY OF THIS NOTICE ON THEM.

All other creditors of the decedent and other persons having claims or demands against decedent's estate must file their claims with this court WITHIN 3 MONTHS AFTER THE DATE OF THE FIRST PUBLICATION OF THIS NOTICE.

ALL CLAIMS NOT FILED WITHIN THE TIME PERIODS SET FORTH IN FLORIDA STATUTES SECTION 733.702 WILL BE FOREVER BARRED.

NOTWITHSTANDING THE TIME PERIODS SET FORTH ABOVE, ANY CLAIM FILED TWO (2) YEARS OR MORE AFTER THE DECEDENT'S DATE OF DEATH IS BARRED.

The date of first publication of this notice is July 15, 2016.

Personal Representative:
JENNY S. SIEG
3030 Starkey Boulevard,
Ste. 190
Trinity, Florida 34655

Attorney for Personal Representative:
JENNY SCAVINO SIEG, ESQ.
Attorney
Florida Bar Number: 0117285
Sieg & Cole, P.A.
3030 Starkey Boulevard,
Ste. 190
Trinity, Florida 34655
Mailing Address: P.O. Box 819,
New Port Richey, FL 34656-0819
Telephone: (727) 842-2237
Fax: (727) 264-0610
E-Mail: jenny@sieglelaw.com
Secondary E-Mail:
eservice@sieglelaw.com
July 15, 22, 2016 16-01993P

SECOND INSERTION

NOTICE TO CREDITORS
(Summary Administration)
IN THE CIRCUIT COURT FOR
PASCO COUNTY, FLORIDA
PROBATE DIVISION
Case No.
512016CP000702CPAXES
IN RE: ESTATE OF
DOROTHY HAIDUVEN
Deceased.

TO ALL PERSONS HAVING CLAIMS OR DEMANDS AGAINST THE ABOVE ESTATE:

You are hereby notified that an Order of Summary Administration has been entered in the Estate of Dorothy Haiduven, deceased, Case No. 512016CP000702CPAXES; by the Circuit Court for Pasco County, Florida, Probate Division, the address of which is 38053 Live Oak Avenue, Suite 207, Dade City, FL 33523-3894; that the decedent's date of death was December 21, 2015; that the total value of the estate is \$16,000 and that the names and addresses of those to whom it has been assigned by such order are:

NAME
Debra E. Haiduven
ADDRESS
501 Old Country Road
Pittsboro, NC 27312
Donna Haiduven, Ph.D.
1406 Whitaker Road
Lutz, FL 33549
Richard G. Haiduven, Jr.
11725 SW 81 Road
Miami, FL 33156

ALL INTERESTED PERSONS ARE NOTIFIED THAT:

All creditors of the estate of decedent and persons having claims or demands against the estate of decedent other than those for whom provision for full payment was made in the Order of Summary Administration must file their claims with this court WITHIN THE TIME PERIODS SET FORTH IN FLORIDA STATUTES SECTION 733.702. ALL CLAIMS AND DEMANDS NOT SO FILED WILL BE FOREVER BARRED. NOTWITHSTANDING ANY OTHER APPLICABLE TIME PERIOD, ANY CLAIM FILED TWO (2) YEARS OR MORE AFTER DECEDENT'S DATE OF DEATH IS BARRED.

The date of first publication of this Notice is July 15, 2016.

Personal Giving Notice:
Debra E. Haiduven
501 Old Country Road
Pittsboro, NC 27312
Attorney for Personal Giving Notice:
Thomas H. Courtney, Esq.
FL Bar No.: 0098795
J. PATRICK FITZGERALD &
ASSOCIATES, P.A.
110 Merrick Way, Suite 3-B
Coral Gables, FL 33134
Telephone: 305-443-9162 ext. 15
Facsimile: 305-443-6613
thc@jpfitzlaw.com
July 15, 22, 2016 16-02011P

OFFICIAL
COURT
HOUSE
WEBSITES:

MANATEE COUNTY:

manateecounty.com

SUNBURG COUNTY:

sunburgcounty.com

CHARLOTTE COUNTY:

charlottecounty.com

LEE COUNTY:

lee-county.com

COLLIER COUNTY:

colliercounty.com

HILLSBOROUGH COUNTY:

hillsboroughcounty.com

PINELAS COUNTY:

pinellascounty.com

PINELLAS COUNTY:

pinellascounty.com

POLK COUNTY:

polk-county.com

ORANGE COUNTY:

orange-county.com

Check out your nation's
leading real estate website

**Business
Observer**

SECOND INSERTION

NOTICE OF ACTION IN THE CIRCUIT COURT OF THE SIXTH JUDICIAL CIRCUIT, IN AND FOR PASCO COUNTY, FLORIDA. CASE NO. 2016CA001850CAAXWS BANK OF AMERICA, N.A., PLAINTIFF, VS. THE UNKNOWN HEIRS, BENEFICIARIES, DEVEISEES, GRANTEES, ASSIGNORS, CREDITORS AND TRUSTEES OF THE ESTATE OF LAURENCE A. RIX A/K/A LAURENCE RIX A/K/A LAWRENCE A. RIX, DECEASED, ET AL. DEFENDANT(S).

To: The Unknown Heirs, Beneficiaries, Devises, Grantees, Assignees, Creditors and Trustees of the Estate of Laurence A. Rix a/k/a Laurence Rix a/k/a Lawrence A. Rix, Deceased RESIDENCE: UNKNOWN LAST KNOWN ADDRESS: 6149 7th Avenue, New Port Richey, FL 34653

YOU ARE HEREBY NOTIFIED that an action to foreclose a mortgage on the following described property located in Pasco County, Florida:

Lot 632, Holiday Garden Estates, Unit Three, according to the Plat thereof, as recorded in Plat Book 11, at Page 13, of the Public Records of Pasco County, Florida

has been filed against you, and you are required to serve a copy of your written defenses, if any, to this action, on Gladstone Law Group, P.A., attorneys for plaintiff, whose address is 1499 W. Palmetto Park Road, Suite 300, Boca Raton, FL 33486, and file the original with the Clerk of the Court, within 30

days after the first publication of this notice, either before 8/15/16 or immediately thereafter, otherwise a default may be entered against you for the relief demanded in the Complaint.

This notice shall be published once a week for two consecutive weeks in the Business Observer.

If you are a person with a disability who needs any accommodation in order to participate in this proceeding, you are entitled, at no cost to you, to the provision of certain assistance. Please contact the Public Information Department at 727-847-8110 in New Port Richey or 352-521-4274, extension 8110 in Dade City or at Pasco County Government Center, 7530 Little Road, New Port Richey, FL 34654 at least 7 days before your scheduled court appearance, or immediately upon receiving this notification if the time before the scheduled appearance is less than 7 days; if you are hearing or voice impaired, call 711.

The court does not provide transportation and cannot accommodate such requests. Persons with disabilities needing transportation to court should contact their local public transportation providers for information regarding transportation services.

DATED: July 7, 2016

Paula S. O'Neil, Ph.D., Clerk & Comptroller
By: Carmella Hernandez
Deputy Clerk of the Court
Gladstone Law Group, P.A.
1499 W. Palmetto Park Road,
Suite 300,
Boca Raton, FL 33486
Our Case #: 16-000533-FHLMC-F
July 15, 22, 2016 16-02008P

SECOND INSERTION

NOTICE OF ACTION - CONSTRUCTIVE SERVICE IN THE CIRCUIT COURT OF THE SIXTH JUDICIAL CIRCUIT IN AND FOR PASCO COUNTY, FLORIDA GENERAL JURISDICTION DIVISION Case No. 2016CA001442CAAXWS Pynnmac Loan Services, LLC Plaintiff, vs. Michelle Ragans; Unknown Spouse of Michelle Ragans; Pasco County Board of County Commissioners (Community Development Division); United States of America on behalf of the Secretary of Housing and Urban Development Defendants.

TO: Unknown Spouse of Michelle Ragans and Michelle Ragans Last Known Address: 3549 Blayton St, New Port Richey, FL 34652

YOU ARE HEREBY NOTIFIED that an action to foreclose a mortgage on the following property in Pasco County, Florida:

LOT 144, COLONIAL MANOR UNIT THREE, ACCORDING TO THE MAP OR PLAT THEREOF AS RECORDED IN PLAT BOOK 8, PAGE 63, OF THE PUBLIC RECORDS OF PASCO COUNTY, FLORIDA.

has been filed against you and you are required to serve a copy of your written defenses, if any, to it on Elizabeth Kim, Esquire, Brock & Scott, PLLC., the Plaintiff's attorney, whose address is 1501 N.W. 49th Street, Suite 200, Ft. Lauderdale, FL 33309, within thirty (30) days of the first date of publication on or before 8/15/16, and file the origi-

nal with the Clerk of this Court either before service on the Plaintiff's attorney or immediately thereafter; otherwise a default will be entered against you for the relief demanded in the complaint or petition.

THIS NOTICE SHALL BE PUBLISHED ONCE A WEEK FOR TWO (2) CONSECUTIVE WEEKS

If you are a person with a disability who needs any accommodation in order to participate in this proceeding, you are entitled, at no cost to you, to the provision of certain assistance. Please contact the Public Information Dept., Pasco County Government Center, 7530 Little Rd., New Port Richey, FL 34654; (727) 847-8110 (V) in New Port Richey; (352) 521-4274, ext 8110 (V) in Dade City, at least 7 days before your scheduled court appearance, or immediately upon receiving this notification if the time before the scheduled appearance is less than 7 days; if you are hearing impaired call 711. The court does not provide transportation and cannot accommodate for this service. Persons with disabilities needing transportation to court should contact their local public transportation providers for information regarding transportation services.

DATED on July 5, 2016.

Paula S. O'Neil, Ph.D., Clerk & Comptroller
By Carmella Hernandez
As Deputy Clerk
Elizabeth Kim, Esquire
Brock & Scott, PLLC.
the Plaintiff's attorney,
1501 N.W. 49th Street, Suite 200
Ft. Lauderdale, FL 33309
File # 16-F03986
July 15, 22, 2016 16-01996P

SECOND INSERTION

NOTICE OF SALE IN THE COUNTY COURT OF THE 6th JUDICIAL CIRCUIT IN AND FOR PASCO COUNTY, FLORIDA UCN: 512015CC002556CCAXES CASE NO: 2015-CC-002556-ES SECTION: D COUNTRY WALK HOMEOWNERS' ASSOCIATION, INC., a not-for-profit Florida corporation, Plaintiff, vs. BRIAN L. GAIEFSKY; UNKNOWN SPOUSE OF BRIAN L. GAIEFSKY; SHARI S. GAIEFSKY; UNKNOWN SPOUSE OF SHARI S. GAIEFSKY; AND UNKNOWN TENANT(S), Defendants.

NOTICE IS HEREBY GIVEN that, pursuant to the Final Judgment entered in this cause, in the County Court of Pasco County, Florida, Paula S. O'Neil, Clerk of Court, will sell all the property situated in Pasco County, Florida described as:

Lot 105, COUNTRY WALK, INCREMENT F, PHASE 1, according to the Plat thereof as recorded in Plat Book 55, Pages 1-11, of the Public Records of Pasco County, Florida, and any subsequent amendments to the aforesaid.

at public sale, to the highest and best bidder, for cash, via the Internet at www.pasco.realforeclose.com at 11:00 A.M. on July 26, 2016.

IF THIS PROPERTY IS SOLD AT PUBLIC AUCTION, THERE MAY BE ADDITIONAL MONEY FROM THE SALE AFTER PAYMENT OF PERSONS WHO ARE ENTITLED TO BE PAID FROM THE SALE PROCEEDS PURSUANT TO THIS FINAL JUDG-

MENT. IF YOU ARE A SUBORDINATE LIENHOLDER CLAIMING A RIGHT TO FUNDS REMAINING AFTER THE SALE, YOU MUST FILE A CLAIM WITH THE CLERK NO LATER THAN 60 DAYS AFTER THE SALE. IF YOU FAIL TO FILE A CLAIM, YOU WILL NOT BE ENTITLED TO ANY REMAINING FUNDS.

If you are a person with a disability who needs any accommodation in order to participate in this proceeding, you are entitled, at no cost to you, to the provision of certain assistance. Please contact the Public Information Dept., Pasco County Government Center, 7530 Little Rd., New Port Richey, FL 34654; (727) 847-8110 (V) in New Port Richey; (352) 521-4274, ext 8110 (V) in Dade City, at least 7 days before your scheduled court appearance, or immediately upon receiving this notification if the time before the scheduled appearance is less than 7 days; if you are hearing impaired call 711. The court does not provide transportation and cannot accommodate for this service. Persons with disabilities needing transportation to court should contact their local public transportation providers for information regarding transportation services.

By BRANDON K. MULLIS, ESQ. FBN: 23217

MANKIN LAW GROUP
Attorney for Plaintiff
E-mail: Service@MankinLawGroup.com
2535 Landmark Drive,
Suite 212
Clearwater, FL 33761
(727) 725-0559
July 15, 22, 2016 16-01997P

SECOND INSERTION

NOTICE OF ACTION IN THE CIRCUIT COURT OF THE SIXTH JUDICIAL CIRCUIT IN AND FOR PASCO COUNTY, FLORIDA CASE NO.: 2015CA002335CAAXWS WELLS FARGO BANK, N.A., Plaintiff, VS. UNKNOWN HEIRS, BENEFICIARIES, DEVEISEES, SURVIVING SPOUSE, GRANTEES, ASSIGNEES, LIENORS, CREDITORS, TRUSTEES, AND ALL OTHER PARTIES CLAIMING AN INTEREST BY, THROUGH, UNDER, OR AGAINST THE ESTATE OF MICHAEL R. POWELL A/K/A MICHAEL RICHARD POWELL, DECEASED; et al., Defendant(s).

TO: Unknown Heirs, Beneficiaries, Devises, Surviving Spouse, Grantees, Assignees, Lienors, Creditors, Trustees, and all Other Parties Claiming an Interest By, Through, Under, or Against the Estate of Michael R. Powell a/k/a Michael Richard Powell, Deceased Last Known Residence: UNKNOWN

YOU ARE HEREBY NOTIFIED that an action to foreclose a mortgage on the following property in Pasco County, Florida:

LOT 71, OF TANGLEWOOD EAST, UNIT ONE ACCORDING TO THE MAP OR PLAT THEREOF AS RECORDED IN PLAT BOOK 10, PAGE 145 AND 146 OF THE PUBLIC RECORDS OF PASCO COUNTY, FLORIDA.

has been filed against you and you are required to serve a copy of your written defenses, if any, to it on ALDRIDGE | PITE, LLP, Plaintiff's attorney, at 1615 South Congress Avenue, Suite 200,

Delray Beach, FL 33445 (Phone Number: (561) 392-6391), within 30 days of the first date of publication of this notice, and file the original with the clerk of this court either before 8/15/16 on Plaintiff's attorney or immediately thereafter; otherwise a default will be entered against you for the relief demanded in the complaint or petition.

If you are a person with a disability who needs any accommodation in order to participate in this proceeding, you are entitled, at no cost to you, to the provision of certain assistance. Please contact the Public Information Dept., Pasco County Government Center, 7530 Little Rd., New Port Richey, FL 34654; (727) 847-8110 (V) in New Port Richey; (352) 521-4274, ext 8110 (V) in Dade City, at least 7 days before your scheduled court appearance, or immediately upon receiving this notification if the time before the scheduled appearance is less than 7 days; if you are hearing impaired call 711. The court does not provide transportation and cannot accommodate for this service. Persons with disabilities needing transportation to court should contact their local public transportation providers for information regarding transportation services.

Dated on July 5, 2016.

Paula S. O'Neil, Ph.D., Clerk & Comptroller
By: Carmella Hernandez
As Deputy Clerk
ALDRIDGE | PITE, LLP
Plaintiff's attorney
1615 South Congress Avenue,
Suite 200
Delray Beach, FL 33445
(Phone Number: (561) 392-6391)
1113-751977B
July 15, 22, 2016 16-01990P

SECOND INSERTION

NOTICE OF ACTION IN THE CIRCUIT COURT OF THE SIXTH JUDICIAL CIRCUIT IN AND FOR PASCO COUNTY, FLORIDA CASE NO.: 2015CA002192CAAXES/J1 FREEDOM MORTGAGE CORPORATION, Plaintiff, VS. ESTATE OF CAROLINE CHECHE A/K/A CAROLINE C. CHECHE A/K/A CAROLINE COLLEEN CHECHE, DECEASED; et al., Defendant(s).

TO: The Estate of Caroline Cheche a/k/a Caroline C. Cheche a/k/a Caroline Colleen Cheche, Deceased Last Known Residence: UNKNOWN

YOU ARE HEREBY NOTIFIED that an action to foreclose a mortgage on the following property in Pasco County, Florida:

LOT 50 AND 51, TERRACE PARK PHASE III, ACCORDING TO THE PLAT THEREOF, AS RECORDED IN PLAT BOOK 40, PAGE 138, OF THE PUBLIC RECORDS OF PASCO COUNTY, FLORIDA. TOGETHER WITH A 2002 FLEETWOOD DOUBLEWIDE MOBILE HOME, FLORIDA TITLE #85936759, IDENTIFICATION #GAFLL234A75193AV21; RP DECAL #12100876 AND FLORIDA TITLE #85963850, IDENTIFICATION #GAFLL-234B75193AV21; RP DECAL #12100878.

has been filed against you and you are required to serve a copy of your written defenses, if any, to it on ALDRIDGE | PITE, LLP, Plaintiff's attorney, at 1615 South Congress Avenue, Suite 200, Delray Beach, FL 33445 (Phone Number:

(561) 392-6391), within 30 days of the first date of publication of this notice, and file the original with the clerk of this court either before AUG 15 2016 on Plaintiff's attorney or immediately thereafter; otherwise a default will be entered against you for the relief demanded in the complaint or petition.

If you are a person with a disability who needs any accommodation in order to participate in this proceeding, you are entitled, at no cost to you, to the provision of certain assistance. Please contact the Public Information Dept., Pasco County Government Center, 7530 Little Rd., New Port Richey, FL 34654; (727) 847-8110 (V) in New Port Richey; (352) 521-4274, ext 8110 (V) in Dade City, at least 7 days before your scheduled court appearance, or immediately upon receiving this notification if the time before the scheduled appearance is less than 7 days; if you are hearing impaired call 711. The court does not provide transportation and cannot accommodate for this service. Persons with disabilities needing transportation to court should contact their local public transportation providers for information regarding transportation services.

Dated on July 11, 2016.

PAULA O'NEIL
As Clerk of the Court
By: Geraldo Salgado
As Deputy Clerk
ALDRIDGE | PITE, LLP
Plaintiff's attorney
1615 South Congress Avenue,
Suite 200
Delray Beach, FL 33445
(Phone Number: (561) 392-6391)
1221-11792B
July 15, 22, 2016 16-02027P

SECOND INSERTION

NOTICE OF ACTION IN THE CIRCUIT COURT OF THE SIXTH JUDICIAL CIRCUIT IN AND FOR PASCO COUNTY, FLORIDA CASE NO.: 2014CA001445CAAXWS BRANCH BANKING AND TRUST COMPANY, Plaintiff, VS. UNKNOWN HEIRS, BENEFICIARIES, DEVEISEES AND ALL OTHER PARTIES CLAIMING AN INTEREST BY, THROUGH, UNDER OR AGAINST THE ESTATE OF HELEN STALEY A/K/A HELEN B. STALEY, DECEASED; et al., Defendant(s).

TO: Lark Crockford Cardoso Eddie Crockford Jeffrey Crockford Last Known Residence: Port Sydney, On POB 110 Jennifer LeBlanc Last Known Residence: 4645 Gazania St, New Port Richey, FL 34652

YOU ARE HEREBY NOTIFIED that an action to foreclose a mortgage on the following property in PASCO County, Florida:

THE SOUTHWEST 1/4 OF LOT 12, PALM LAKES TERRACE, ACCORDING TO MAP OR PLAT THEREOF AS RECORDED IN PLAT BOOK 5, PAGES 140, OF THE PUBLIC RECORDS OF PASCO COUNTY, FLORIDA.

has been filed against you and you are required to serve a copy of your written defenses, if any, to it on ALDRIDGE | PITE, LLP, Plaintiff's attorney, at 1615 South Congress Avenue, Suite 200, Delray Beach, FL 33445 (Phone Number: (561) 392-6391), within 30

days of the first date of publication of this notice, and file the original with the clerk of this court either before 8/15/16 on Plaintiff's attorney or immediately thereafter; otherwise a default will be entered against you for the relief demanded in the complaint or petition.

If you are a person with a disability who needs any accommodation in order to participate in this proceeding, you are entitled, at no cost to you, to the provision of certain assistance. Please contact the Public Information Dept., Pasco County Government Center, 7530 Little Rd., New Port Richey, FL 34654; (727) 847-8110 (V) in New Port Richey; (352) 521-4274, ext 8110 (V) in Dade City, at least 7 days before your scheduled court appearance, or immediately upon receiving this notification if the time before the scheduled appearance is less than 7 days; if you are hearing impaired call 711. The court does not provide transportation and cannot accommodate for this service. Persons with disabilities needing transportation to court should contact their local public transportation providers for information regarding transportation services.

Dated on July 5, 2016.

Paula S. O'Neil, Ph.D., Clerk & Comptroller
By: Carmella Hernandez
As Deputy Clerk
ALDRIDGE | PITE, LLP
Plaintiff's attorney
1615 South Congress Avenue,
Suite 200
Delray Beach, FL 33445
(Phone Number: (561) 392-6391)
1212-749B
July 15, 22, 2016 16-01989P

SECOND INSERTION

NOTICE OF ACTION FORECLOSURE PROCEEDINGS-PROPERTY IN THE CIRCUIT COURT OF THE SIXTH JUDICIAL CIRCUIT OF FLORIDA, IN AND FOR PASCO COUNTY Case #: 51-2012-CA-005295-ES DIVISION: J1 JPMorgan Chase Bank, National Association Plaintiff, -vs- Rosa Maria Smith a/k/a Rosa M. Smith Defendant(s).

TO: Unknown Spouse of Angelika A. Ross and Unknown Spouse of Rosa Maria Smith a/k/a Rosa M. Smith, Whose Last Known Address is: 24811 Gun Smoke Drive, Land O Lakes, FL 34639 Residence unknown, if living, including any unknown spouse of the said Defendants, if either has remarried and if either or both of said Defendants are dead, their respective unknown heirs, devisees, grantees, assignees, creditors, lienors, and trustees, and all other persons claiming by, through, under or against the named Defendant(s); and the aforementioned named Defendant(s) and such of the aforementioned unknown Defendants and such of the aforementioned unknown Defendants as may be infants, incompetents or otherwise not sui juris.

YOU ARE HEREBY NOTIFIED that an action has been commenced to foreclose a mortgage on the following real property, lying and being and situated in Pasco County, Florida, more particularly described as follows:

LOT 14 BLOCK 2, STAGE-COACH VILLAGE PARCEL 4, PHASE 2, ACCORDING TO THE PLAT THEREOF, AS RE-

CORDED IN PLAT BOOK 36 AT PAGE 133 THROUGH 135, OF THE PUBLIC RECORDS OF PASCO COUNTY, FLORIDA.

This action has been filed against you and you are required to serve a copy of your written defense, if any, upon SHAPIRO, FISHMAN & GACHÉ, LLP, Attorneys for Plaintiff, whose address is 4630 Woodland Corporate Blvd., Suite 100, Tampa, FL 33614 within thirty (30) days after the first publication of this notice and file the original with the clerk of this Court either before service on Plaintiff's attorney or immediately thereafter; otherwise a default will be entered against you for the relief demanded in the Complaint.

If you are a person with a disability who needs any accommodation in order to participate in this proceeding, you are entitled, at no cost to you, to the provision of certain assistance. Please contact the ADA Coordinator; 14250 49th Street North, Clearwater, Florida 33762 (727) 453-7163 at least 7 days before your scheduled court appearance, or immediately upon receiving this notification of the time before the scheduled appearance is less than 7 days. If you are hearing or voice impaired, call 711.

WITNESS my hand and seal of this Court on the 11th day of July, 2016.

Paula S. O'Neil
Clerk of Circuit Court
By: Gerald Salgado
Deputy Clerk
SHAPIRO, FISHMAN & GACHÉ, LLP
Attorneys for Plaintiff
4630 Woodland Corporate Blvd.,
Suite 100
Tampa, FL 33614
15-286322
July 15, 22, 2016 16-02043P

SECOND INSERTION

NOTICE OF FORECLOSURE SALE PURSUANT TO CHAPTER 45 IN THE CIRCUIT COURT OF THE SIXTH JUDICIAL CIRCUIT IN AND FOR PASCO COUNTY, FLORIDA CASE NO.: 2015CA003381CAAXWS PINGORA LOAN SERVICING, LLC, Plaintiff, VS. RYAN R. FERGUSON; et al., Defendant(s).

NOTICE IS HEREBY GIVEN that sale will be made pursuant to an Order or Final Judgment. Final Judgment was awarded on June 16, 2016 in Civil Case No. 2015CA003381CAAXWS, of the Circuit Court of the SIXTH Judicial Circuit in and for Pasco County, Florida, wherein, PINGORA LOAN SERVICING, LLC is the Plaintiff, and RYAN R. FERGUSON; AMANDA S. FERGUSON; ANY AND ALL UNKNOWN PARTIES CLAIMING BY, THROUGH, UNDER AND AGAINST THE HEREIN NAMED INDIVIDUAL DEFENDANT(S) WHO ARE NOT KNOWN TO BE DEAD OR ALIVE, WHETHER SAID UNKNOWN PARTIES MAY CLAIM AN INTEREST AS SPOUSES, HEIRS, DEVEISEES, GRANTEES, OR OTHER CLAIMANTS are Defendants.

The clerk of the court, Paula S. O'Neil, Ph.D. will sell to the highest bidder for cash at www.pasco.realforeclose.com on August 8, 2016 at 11:00 AM, the following described real property as set forth in said Final Judgment, to wit:

LOT 235, OF TANGLEWOOD EAST, UNIT FOUR, ACCORDING TO THE PLAT THEREOF, AS RECORDED IN PLAT BOOK 12, PAGE 37, OF THE PUBLIC RECORDS OF PASCO COUNTY, FLORIDA.

ANY PERSON CLAIMING AN INTEREST IN THE SURPLUS FROM

THE SALE, IF ANY, OTHER THAN THE PROPERTY OWNER AS OF THE DATE OF THE LIS PENDENS MUST FILE A CLAIM WITHIN 60 DAYS AFTER THE SALE.

IMPORTANT AMERICANS WITH DISABILITIES ACT: If you are a person with a disability who needs an accommodation in order to participate in this proceeding, you are entitled, at no cost to you, to the provision of certain assistance. Please contact: Public Information Dept., Pasco County Government Center, 7530 Little Rd., New Port Richey, FL 34654; Phone: 727.847.8110 (voice) in New Port Richey, 352.521.4274, ext 8110 (voice) in Dade City, Or 711 for the hearing impaired. Contact should be initiated at least seven days before the scheduled court appearance, or immediately upon receiving this notification if the time before the scheduled appearance is less than seven days. The court does not provide transportation and cannot accommodate such requests. Persons with disabilities needing transportation to court should contact their local public transportation providers for information regarding transportation services.

Dated this 12 day of July, 2016.

By: Susan Sparks
FBN: 33626
for Susan W. Findley, Esq.
FBN: 160600
Primary E-Mail:
ServiceMail@aldridgepите.com
ALDRIDGE | PITE, LLP
Attorney for Plaintiff
1615 South Congress Avenue Suite 200
Delray Beach, FL 33445
Telephone: (844) 470-8804
Facsimile: (561) 392-6965
1454-102B
July 15, 22, 2016 16-02036P

SECOND INSERTION

NOTICE OF FORECLOSURE SALE IN THE CIRCUIT COURT OF THE SIXTH JUDICIAL CIRCUIT, IN AND FOR PASCO COUNTY, FLORIDA CIVIL DIVISION CASE NO. : 51-2009-CA-011739ES THE BANK OF NEW YORK MELLON FKA THE BANK OF NEW YORK, AS TRUSTEE FOR THE CERTIFICATEHOLDERS OF THE CWALT, INC., ALTERNATIVE LOAN TRUST2007-OA10 MORTGAGE PASS-THROUGH CERTIFICATES, SERIES 2007-OA10 Plaintiff, vs. YVETTE SANTACRUZ AKA YVETTE C SANTACRUZ JOSE SANTACRUZ, et al., Defendants.

NOTICE IS HEREBY GIVEN pursuant to an Order of Final Judgment entered in Case No. 51-2009-CA-011739ES in the Circuit Court of the SIXTH Judicial Circuit in and for PASCO County, Florida, wherein, THE BANK OF NEW YORK MELLON FKA THE BANK OF NEW YORK, AS TRUSTEE FOR THE CERTIFICATEHOLDERS OF THE CWALT, INC., ALTERNATIVE LOAN TRUST2007-OA10 MORTGAGE PASS-THROUGH CERTIFICATES, SERIES 2007-OA10, Plaintiff, and, YVETTE SANTACRUZ AKA YVETTE C SANTACRUZ JOSE SANTACRUZ, et al., are Defendants. The Clerk of Court will sell to the highest bidder for cash www.pasco.realforeclose.com at the hour of 11:00AM, on the 11th day of August, 2016, the following described property:

LOT 103, COUNTRY WALK INCREMENT E PHASE 1, ACCORDING TO THE PLAT

THEREOF RECORDED IN PLAT BOOK 55, PAGES 75 TO 83, INCLUSIVE, OF THE PUBLIC RECORDS OF PASCO COUNTY, FLORIDA.

Any person claiming an interest in the surplus from the sale, if any, other than the property owner as of the date of the Lis Pendens must file a claim within 60 days after the sale.

IMPORTANT If you are a person with a disability who needs any accommodation in order to participate in this proceeding, you are entitled, at no cost to you, to the provision of certain assistance. Within two (2) working days of your receipt of this (describe notice/order) please contact the Public Information Dept., Pasco County Government Center, 7530 Little Rd., New Port Richey, FL 34654; (727) 8478110 (V) in New Port Richey; (352) 521-4274, ext. 8110 (V) in Dade City; via 1-800-955-8771 if you are hearing impaired. The court does not provide transportation and cannot accommodate for this service. Persons with disabilities needing transportation to court should contact their local public transportation providers for information regarding disabled transportation services.

DATED this 6 day of July, 2016.

Matthew Klein
FBN: 73529
MILLENNIUM PARTNERS
Attorneys for Plaintiff
Primary E-Mail Address:
service@millenniumpartners.net
21500 Biscayne Blvd.,
Suite 600
Aventura, FL 33180
Telephone: (305) 698-5839
Facsimile: (305) 698-5840
MP # 11-002279-1
July 15, 22, 2016 16-02046P

SECOND INSERTION

NOTICE OF RESCHEDULED FORECLOSURE SALE IN THE CIRCUIT COURT OF THE SIXTH JUDICIAL CIRCUIT IN AND FOR PASCO COUNTY, FLORIDA
GENERAL JURISDICTION DIVISION

Case No. 51-2009-CA-011275-WS
WELLS FARGO BANK, NA, Plaintiff, vs. Robert Nigro, et al, Defendants.

NOTICE IS HEREBY GIVEN pursuant to an order on Motion to Cancel and Reset Foreclosure Sale, dated June 13, 2016, entered in Case No. 51-2009-CA-011275-WS of the Circuit Court of the Sixth Judicial Circuit, in and for Pasco County, Florida, wherein WELLS FARGO BANK, NA is the Plaintiff and Robert Nigro; The Unknown Spouse of Robert T. Nigro; Any and All Unknown Parties Claiming by, Through, Under and Against the Herein Named Individual Defendant(s) who are not Known to be Dead or Alive, Whether said Unknown Parties may Claim an Interest as Spouses, Heirs, Devisees, Grantees, or other Claimants; Tenant #1; Tenant #2; Unknown Tenant(s) In Possession are the Defendants, that Paula O'Neil, Pasco County Clerk of Court will sell to the highest and best bidder for cash by electronic sale at www.pasco.realforeclose.com, beginning at 11:00 AM on the 4th day of August, 2016, the following described property as set forth in said Final Judgment, to wit:

LOT 19, WOOD TRAIL VILLAGE UNIT 2-B, ACCORDING TO THE PLAT THEREOF RE-

CORDED IN PLAT BOOK 23, PAGES 101 THROUGH 103, OF THE PUBLIC RECORDS OF PASCO COUNTY, FLORIDA

Any person claiming an interest in the surplus from the sale, if any, other than the property owner as of the date of the lis pendens must file a claim within 60 days after the sale.

If you are a person with a disability who needs any accommodation in order to participate in this proceeding, you are entitled, at no cost to you, to the provision of certain assistance. Please contact the Public Information Dept., Pasco County Government Center, 7530 Little Rd., New Port Richey, FL 34654; (727) 847-8110 (V) in New Port Richey; (352) 521-4274, ext 8110 (V) in Dade City, at least 7 days before your scheduled court appearance, or immediately upon receiving this notification if the time before the scheduled appearance is less than 7 days; if you are hearing impaired call 711. The court does not provide transportation and cannot accommodate for this service. Persons with disabilities needing transportation to court should contact their local public transportation providers for information regarding transportation services.

By Jimmy Edwards, Esq.
Florida Bar No. 81855

BROCK & SCOTT, PLLC
Attorney for Plaintiff
1501 N.W. 49th Street, Suite 200
Ft. Lauderdale, FL 33309
Phone: (954) 618-6955, ext. 6209
Fax: (954) 618-6954
FLCourtDocs@brockandscott.com
File # 15-F09442
July 15, 22, 2016 16-02030P

SECOND INSERTION

NOTICE OF RESCHEDULED SALE IN THE CIRCUIT COURT OF THE SIXTH JUDICIAL CIRCUIT IN AND FOR PASCO COUNTY, FLORIDA
CIVIL ACTION
CASE NO.:

51-2009-CA-005122WS
BANK OF AMERICA, N.A., Plaintiff, vs. TSOULEAS, VASILIOS et al, Defendant(s).

NOTICE IS HEREBY GIVEN Pursuant to an Order Rescheduling Foreclosure Sale dated June 24, 2016, and entered in Case No. 51-2009-CA-005122WS of the Circuit Court of the Sixth Judicial Circuit in and for Pasco County, Florida in which Bank Of America, N.A., is the Plaintiff and Elenie Tsoules, Mortgage Electronic Registration Systems, Incorporated as Nominee for Contrywide Home Loans, Inc., Vasiliios Tsoules, are defendants, the Pasco County Clerk of the Circuit Court will sell to the highest and best bidder for cash in/on held online www.pasco.realforeclose.com in Pasco County, Florida at 11:00AM on the 11th day of August, 2016, the following described property as set forth in said Final Judgment of Foreclosure:

LOT 48, BLOCK 1, FLORE-A-MAR, SECTION 17-B, ACCORDING TO THE MAP OR PLAT THEREOF AS RECORDED IN PLAT BOOK 10, PAGE 131, OF THE PUBLIC RECORDS OF PASCO COUNTY, FLORIDA.
A/K/A 4814 SHELL STREAM BOULEVARD, NEW PORT RICHEY, FL 34652

Any person claiming an interest in the surplus from the sale, if any, other than

the property owner as of the date of the Lis Pendens must file a claim within 60 days after the sale.

If you are a person with a disability who needs an accommodation in order to participate in this proceeding, you are entitled, at no cost to you, to the provision of certain assistance. Please contact:

Public Information Dept., Pasco County Government Center, 7530 Little Rd., New Port Richey, FL 34654
Phone: 727.847.8110 (voice) in New Port Richey or 352.521.4274, ext 8110 (voice) in Dade City or 711 for the hearing impaired.

Contact should be initiated at least seven days before the scheduled court appearance, or immediately upon receiving this notification if the time before the scheduled appearance is less than seven days.

The court does not provide transportation and cannot accommodate such requests. Persons with disabilities needing transportation to court should contact their local public transportation providers for information regarding transportation services.

Dated in Hillsborough County, Florida this 12th day of July, 2016.

Brian Gilbert, Esq.
FL Bar # 116697

Albertelli Law
Attorney for Plaintiff
P.O. Box 23028
Tampa, FL 33623
(813) 221-4743
(813) 221-9171 facsimile
eService: servealaw@albertellilaw.com
JR - 12-109696
July 15, 22, 2016 16-02033P

SECOND INSERTION

NOTICE OF FORECLOSURE SALE IN THE CIRCUIT COURT OF THE SIXTH JUDICIAL CIRCUIT IN AND FOR PASCO COUNTY, FLORIDA
GENERAL JURISDICTION DIVISION

Case No. 2015CA004056CAAXES
The Bank of New York Mellon FKA The Bank of New York as Trustee for the Certificateholders of the CWABS, Inc., Asset-Backed Certificates, Series 2005-8, Plaintiff, vs. Patrick Maender a/k/a Patrick J. Maender, et al, Defendants.

NOTICE IS HEREBY GIVEN pursuant to an order Granting Motion to Reset Foreclosure Sale, dated June 7, 2016, entered in Case No. 2015CA004056CAAXES of the Circuit Court of the Sixth Judicial Circuit, in and for Pasco County, Florida, wherein The Bank of New York Mellon FKA The Bank of New York as Trustee for the Certificateholders of the CWABS, Inc., Asset-Backed Certificates, Series 2005-8 is the Plaintiff and Patrick Maender a/k/a Patrick J. Maender; Cheryl Maender; Grand Oaks Master Association, Inc.; Grand Oaks Association, Inc. are the Defendants, that Paula O'Neil, Pasco County Clerk of Court will sell to the highest and best bidder for cash by electronic sale at www.pasco.realforeclose.com, beginning at 11:00 AM on the 9th day of August, 2016, the following described property as set forth in said Final Judgment, to wit:

LOT 18, BLOCK 1, OF GRAND OAKS PHASE 3, ACCORDING TO THE PLAT THEREOF, RE-

CORDED IN PLAT BOOK 50, PAGE 112, OF THE PUBLIC RECORDS OF PASCO COUNTY, FLORIDA.

Any person claiming an interest in the surplus from the sale, if any, other than the property owner as of the date of the lis pendens must file a claim within 60 days after the sale.

If you are a person with a disability who needs any accommodation in order to participate in this proceeding, you are entitled, at no cost to you, to the provision of certain assistance. Please contact the Public Information Dept., Pasco County Government Center, 7530 Little Rd., New Port Richey, FL 34654; (727) 847-8110 (V) in New Port Richey; (352) 521-4274, ext 8110 (V) in Dade City, at least 7 days before your scheduled court appearance, or immediately upon receiving this notification if the time before the scheduled appearance is less than 7 days; if you are hearing impaired call 711. The court does not provide transportation and cannot accommodate for this service. Persons with disabilities needing transportation to court should contact their local public transportation providers for information regarding transportation services.

By Jimmy Edwards, Esq.
Florida Bar No. 81855

BROCK & SCOTT, PLLC
Attorney for Plaintiff
1501 N.W. 49th Street, Suite 200
Ft. Lauderdale, FL 33309
Phone: (954) 618-6955, ext. 6209
Fax: (954) 618-6954
FLCourtDocs@brockandscott.com
File # 15-F02795
July 15, 22, 2016 16-02031P

SECOND INSERTION

NOTICE OF SALE Pursuant to Chapter 45 IN THE CIRCUIT COURT OF THE 6TH JUDICIAL CIRCUIT IN AND FOR PASCO COUNTY, FLORIDA
GENERAL JURISDICTION DIVISION
CASE NO.:

2016CA000191CAAXES
Concord Station Community Association, Inc., a Florida Non Profit Corporation, Plaintiff, v. Hector Vega, Defendant(s).

NOTICE OF SALE IS HEREBY GIVEN pursuant to an Order of Final Judgment of Foreclosure dated June 29, 2016 and entered in Case No. 2016CA000191CAAXES of the Circuit Court of the Sixth Judicial Circuit in and for Pasco County, Florida wherein Concord Station Community Association, Inc., is Plaintiff, and Hector Vega, is the Defendant, the Clerk of Court will sell to the highest and best bidder for cash on www.pasco.realforeclose.com at 11:00 o'clock A.M. on the 11th day of August, 2016, the following described property as set forth in said Order of Final Judgment to wit:

LOT 31, IN BLOCK F, OF CONCORD STATION PHASE 4 UNITS A&B, ACCORDING TO THE PLAT THEREOF, AS RECORDED IN PLAT BOOK 60, PAGE 110, OF THE PUBLIC RECORDS OF PASCO COUNTY, FLORIDA.
Property Address: 18305 Holland House Loop, Land O' Lakes, FL 34638.

Any person claiming an interest in the surplus from the sale, if any, other than the property owner as of the date of the Lis Pendens must file a claim within sixty (60) Days after the sale.

AMERICANS WITH DISABILITIES ACT ASSISTANCE If you are a person with a disability who needs any accommodation in order to participate in this proceeding, you are entitled, at no cost to you, to the provision of certain assistance. Please contact the Public Information Dept., Pasco County Government Center, 7530 Little Rd., New Port Richey, FL 34654; (727) 847-8110 (V) in New Port Richey; (352) 521-4274, ext 8110 (V) in Dade City, at least 7 days before your scheduled court appearance, or immediately upon receiving this notification if the time before the scheduled appearance is less than 7 days; if you are hearing impaired call 711. The court does not provide transportation and cannot accommodate for this service. Persons with disabilities needing transportation to court should contact their local public transportation providers for information regarding transportation services.

Dated this 7 day of July, 2016.
ASSOCIATION LAW GROUP, P.L.
Attorney for the Plaintiff
By: David W. Krempa, Esq.,
Florida Bar No. 59139
Primary Email: luis@algpl.com
Secondary Email: filings@algpl.com
Association Law Group, P.L.
Post Office Box 311059
Miami, Florida 33231
Phone: (305) 938-6922
Fax: (305) 938-6914
July 15, 22, 2016 16-02034P

SECOND INSERTION

NOTICE OF RESCHEDULED FORECLOSURE SALE IN THE CIRCUIT COURT OF THE SIXTH JUDICIAL CIRCUIT IN AND FOR PASCO COUNTY, FLORIDA
GENERAL JURISDICTION DIVISION
Case No.

51-2012-CA-008369-CAAX-ES
Owren Loan Servicing, LLC, Plaintiff, vs. Erik Peppers; Natalie Peppers, et al, Defendants.

NOTICE IS HEREBY GIVEN pursuant to an Order Granting Motion to Reset Foreclosure Sale, dated May 31, 2016, entered in Case No. 51-2012-CA-008369-CAAX-ES of the Circuit Court of the Sixth Judicial Circuit, in and for Pasco County, Florida, wherein Owren Loan Servicing, LLC is the Plaintiff and Erik Peppers; Natalie Peppers; Any and All Unknown Parties Claiming By Through Under and Against the Herein Named Individual Defendant(s) Who Are Not Known to be Dead or Alive, Whether Said Unknown Parties May Claim an Interest as Spouses, Heirs, Devisees, Grantees, or Other Claimants; John Tenant and Jane Tenant whose names are fictitious to account for parties in possession are the Defendants, that Paula O'Neil, Pasco County Clerk of Court will sell to the highest and best bidder for cash by electronic sale at www.pasco.realforeclose.com, beginning at 11:00 AM on the 3rd day of August, 2016, the following described property as set forth in said Final Judgment, to wit:

LOT 16, WHISPERING OAKS, AS PER MAP OR PLAT

THEREOF RECORDED IN PLAT BOOK 14, PAGES 86 AND 87, PUBLIC RECORDS OF PASCO COUNTY, FLORIDA.

Any person claiming an interest in the surplus from the sale, if any, other than the property owner as of the date of the lis pendens must file a claim within 60 days after the sale.

If you are a person with a disability who needs any accommodation in order to participate in this proceeding, you are entitled, at no cost to you, to the provision of certain assistance. Please contact the Public Information Dept., Pasco County Government Center, 7530 Little Rd., New Port Richey, FL 34654; (727) 847-8110 (V) in New Port Richey; (352) 521-4274, ext 8110 (V) in Dade City, at least 7 days before your scheduled court appearance, or immediately upon receiving this notification if the time before the scheduled appearance is less than 7 days; if you are hearing impaired call 711. The court does not provide transportation and cannot accommodate for this service. Persons with disabilities needing transportation to court should contact their local public transportation providers for information regarding transportation services.

By Jimmy Edwards, Esq.
Florida Bar No. 81855

BROCK & SCOTT, PLLC
Attorney for Plaintiff
1501 N.W. 49th Street, Suite 200
Ft. Lauderdale, FL 33309
Phone: (954) 618-6955, ext. 6209
Fax: (954) 618-6954
FLCourtDocs@brockandscott.com
File # 14-F01290
July 15, 22, 2016 16-02029P

SECOND INSERTION

NOTICE OF ACTION IN THE CIRCUIT COURT OF THE SIXTH JUDICIAL CIRCUIT IN AND FOR PASCO COUNTY, FLORIDA
CIVIL ACTION
CASE NO.

2015-CA-3357-WS
Division J-2

SUNCOAST CREDIT UNION Plaintiff, v.

GARY L. FOOTE; UNKNOWN SPOUSE OF GARY L. FOOTE, IF ANY; VALLEY WOOD HOMEOWNERS ASSOCIATION, INC.; and ANY UNKNOWN PERSONS IN POSSESSION, Defendants.

TO: GARY L. FOOTE, UNKNOWN HEIRS, DEVISEES AND BENEFICIARIES OF GARY L. FOOTE, deceased; UNKNOWN SPOUSES OF UNKNOWN HEIRS, DEVISEES AND BENEFICIARIES OF GARY L. FOOTE, deceased

YOU ARE NOTIFIED that an action to foreclose a mortgage on the following property in Pasco County, Florida:

Lot 61, Valley Wood Unit 32 Tall Pines at River Ridge, a subdivision according to the plat thereof recorded at Plat Book 31, Pages 148-149, in the Public Records of Pasco County, Florida.

has been filed against you and you are required to serve a copy of your written defenses, if any, to it Shannon M. Puopolo, Plaintiff's attorney, of the law firm of Henderson, Franklin, Starnes & Holt, P.A., whose address is Post Office Box 280, Fort Myers, Florida 33902, * on or before 8/15/16 within thirty (30) days after the first publication of the notice

and file the original with the Clerk of this court either before service on Plaintiff's attorney or immediately thereafter; otherwise a default will be entered against you for the relief demanded in the complaint or petition.

If you are a person with a disability who needs any accommodation in order to participate in this proceeding, you are entitled, at no cost to you, to the provision of certain assistance. Please contact the Public Information Dept., Pasco County Government Center, 7530 Little Rd., New Port Richey, FL 34654; (727) 847-8110 (V) in New Port Richey; (352) 521-4274, ext 8110 (V) in Dade City, at least 7 days before your scheduled court appearance, or immediately upon receiving this notification if the time before the scheduled appearance is less than 7 days; if you are hearing impaired call 711. The court does not provide transportation and cannot accommodate for this service. Persons with disabilities needing transportation to court should contact their local public transportation providers for information regarding transportation services.

WITNESS my hand and seal of this Court on the 5 day of July, 2016.

D.
Paula S. O'Neil, Ph.D.,
Clerk & Comptroller

By: Camella Hernandez
Deputy Clerk
Shannon M. Puopolo,
Plaintiff's attorney

Henderson, Franklin,
Starnes & Holt, P.A.
Post Office Box 280
Fort Myers, Florida 33902
July 15, 22, 2016 16-01992P

SECOND INSERTION

NOTICE OF SALE PURSUANT TO CHAPTER 45 IN THE CIRCUIT COURT OF THE 6TH JUDICIAL CIRCUIT IN AND FOR PASCO COUNTY, FLORIDA
CASE NO.

51-2014-CA-004491-WS
THE BANK OF NEW YORK MELLON TRUST COMPANY, N.A. AS SUCCESSOR IN INTEREST TO ALL PERMITTED SUCCESSORS AND ASSIGNS OF THE JPMORGAN CHASE BANK, AS TRUSTEE FOR SPECIALTY UNDERWRITING AND RESIDENTIAL FINANCE TRUST MORTGAGE LOAN ASSET-BACKED CERTIFICATES, SERIES 2003-BC3, Plaintiff, vs. CHRISTINE L. MIALE, ET AL., Defendants,

NOTICE OF SALE IS HEREBY GIVEN pursuant to a Uniform Final Judgment of Foreclosure dated June 9, 2016, and entered in Case No. 51-2014-CA-004491-WS of the Circuit Court of the 6th Judicial Circuit in and for Pasco County, Florida, wherein THE BANK OF NEW YORK MELLON TRUST COMPANY, N.A. AS SUCCESSOR IN INTEREST TO ALL PERMITTED SUCCESSORS AND ASSIGNS OF THE JPMORGAN CHASE BANK, AS TRUSTEE FOR SPECIALTY UNDERWRITING AND RESIDENTIAL FINANCE TRUST MORTGAGE LOAN ASSET-BACKED CERTIFICATES, SERIES 2003-BC3, is Plaintiff, and CHRISTINE L. MIALE, ET AL., are the Defendants, the Office of Paula S. O'Neil, Pasco County Clerk of the Court will sell to the highest and best bidder for cash via online auction at www.pasco.realforeclose.com at 11:00 A.M. on the 3rd day of August, 2016, the following described property as set forth in said Final Judgment, to wit:

Lot 150, Embassy Hills Unit 1,

according to the plat thereof recorded in Plat Book 11, Pages 86-88, of the Public Records of Pasco County, Florida.

Property Address: 9301 Crabtree Lane, Port Richey, Florida 34668 and all fixtures and personal property located therein or thereon, which are included as security in Plaintiff's mortgage.

Any person claiming an interest in the surplus funds from the sale, if any, other than the property owner as of the date of the lis pendens must file a claim within 60 days after the sale.

If you are a person with a disability who needs any accommodation in order to participate in this proceeding, you are entitled, at no cost to you, to the provision of certain assistance. Please contact the Public Information Dept., Pasco County Government Center, 7530 Little Rd., New Port Richey, FL 34654; (727) 847-8110 (V) in New Port Richey; (352) 521-4274, ext 8110 (V) in Dade City, at least 7 days before your scheduled court appearance, or immediately upon receiving this notification if the time before the scheduled appearance is less than 7 days; if you are hearing impaired call 711. The court does not provide transportation and cannot accommodate for this service. Persons with disabilities needing transportation to court should contact their local public transportation providers for information regarding transportation services.

Dated this 6th day of July, 2016.
By: Jared Lindsey, Esq.
FBN: 081974

Clarfield, Okon, Salomone & Pincus, P.L.
500 S. Australian Avenue,
Suite 730
West Palm Beach, FL 33401
Telephone: (561) 713-1400
Facsimile: (561) 713-1401
Email: pleadings@copslaw.com
July 15, 22, 2016 16-01986P

SECOND INSERTION

NOTICE OF ACTION - CONSTRUCTIVE SERVICE IN THE CIRCUIT COURT OF THE SIXTH JUDICIAL CIRCUIT IN AND FOR PASCO COUNTY, FLORIDA
GENERAL JURISDICTION DIVISION

Case No. 2016CA001197CAAXES/J1
Citizens Bank NA F/K/A RBS Plaintiff, vs.

Theodore E. Dubay; Paula J. Dubay; The Unknown Heirs, Devisees, Grantees, Assignees, Lienors, Creditors, Trustees, and all other parties claiming interest by, through, under or against the Estate of Patricia L. Guay, Deceased; Marc E. Guay a/k/a Marc Guay; Megahn M. Seremet f/k/a Meghan Michele Schaub; Patricia Regina Walynski f/k/a Patricia R. Schaub; Adele Alyse Faria a/k/a Adele A. Faria a/k/a Adele Faria; Paradise Lakes Condominium Association, Inc. Defendants.

TO: The Unknown Heirs, Devisees, Grantees, Assignees, Lienors, Creditors, Trustees, and all other parties claiming interest by, through, under or against the Estate of Patricia L. Guay, Deceased Last Known Address: Unknown
YOU ARE HEREBY NOTIFIED that an action to foreclose a mortgage on the following property in Pasco County, Florida:

UNIT 7, BUILDING U, OF PARADISE LAKE RESORT CONDOMINIUM, A CONDOMINIUM, ACCORDING TO THE DECLARATION OF CONDOMINIUM THEREOF, AS RECORDED IN OFFICIAL RECORDS BOOK 1159, PAGE 1382 AND RECORDED IN OFFICIAL RECORDS BOOK 1160, PAGE 296, AND ANY AMENDMENTS THERETO, AND ACCORDING TO THE PLAT THEREOF, AS RECORDED IN CONDOMINIUM PLAT BOOK 20, PAGES 88 - 94, INCLUSIVE AND AMENDED IN CONDOMINIUM PLAT BOOK 22, PAGES 129 - 137, INCLUSIVE, OF THE PUBLIC

RECORDS OF PASCO COUNTY, FLORIDA, TOGETHER WITH AN UNDIVIDED INTEREST IN THE COMMON ELEMENTS APPURTENANT THERETO.

has been filed against you and you are required to serve a copy of your written defenses, if any, to it on David Echavarría, Esquire, Brock & Scott, PLLC, the Plaintiff's attorney, whose address is 1501 N.W. 49th Street, Suite 200, Ft. Lauderdale, FL 33309, within thirty (30) days of the first date of publication on or before AUG 15 2016, and file the original with the Clerk of this Court either before service on the Plaintiff's attorney or immediately thereafter; otherwise a default will be entered against you for the relief demanded in the complaint or petition.

THIS NOTICE SHALL BE PUBLISHED ONCE A WEEK FOR TWO (2) CONSECUTIVE WEEKS

If you are a person with a disability who needs any accommodation in order to participate in this proceeding, you are entitled, at no cost to you, to the provision of certain assistance. Please contact the Public Information Dept., Pasco County Government Center, 7530 Little Rd., New Port Richey, FL 34654; (727) 847-8110 (V) in New Port Richey; (352) 521-4274, ext 8110 (V) in Dade City, at least 7 days before your scheduled court appearance, or immediately upon receiving this notification if the time before the scheduled appearance is less than 7 days; if you are hearing impaired call 711. The court does not provide transportation and cannot accommodate for this service. Persons with disabilities needing transportation to court should contact their local public transportation providers for information regarding transportation services.

DATED ON JUL 11 2016.

Paula O'Neil
As Clerk of the Court
By Gerald Salgado
As Deputy Clerk
David Echavarría, Esquire
Brock & Scott, PLLC,
the Plaintiff's attorney,
1501 N.W. 49th Street, Suite 200
Ft. Lauderdale, FL 33309
File # 15-F02594
July 15, 22, 2016 16-02047P

OFFICIAL COURT HOUSE WEBSITES:

MANATEE COUNTY:
manateeclerk.com

SARASOTA COUNTY:
sarasotaclerk.com

CHARLOTTE COUNTY:
charlotte.realforeclose.com

LEE COUNTY:
leeclerk.org

COLLIER COUNTY:
collierclerk.com

HILLSBOROUGH COUNTY:
hillsclerk.com

PASCO COUNTY:
pasco.realforeclose.com

PINELLAS COUNTY:
pinellasclerk.org

POLK COUNTY:
polkcountyclerk.net

ORANGE COUNTY:
myorangeclerk.com

Check out your notices on: floridapublicnotices.com

Business Observer

SECOND INSERTION

RE-NOTICE OF SALE PURSUANT TO CHAPTER 45 IN THE CIRCUIT COURT OF THE SIXTH JUDICIAL CIRCUIT, IN AND FOR PASCO COUNTY, FLORIDA

CASE NO.: 2015-CA-003790
U.S. BANK NATIONAL ASSOCIATION, AS TRUSTEE, SUCCESSOR IN INTEREST TO BANK OF AMERICA, NATIONAL ASSOCIATION, AS TRUSTEE, SUCCESSOR BY MERGER TO LASALLE BANK NATIONAL ASSOCIATION, AS TRUSTEE FOR THE HOLDERS OF THE RAAC SERIES 2007-SP3 TRUST, MORTGAGE ASSET-BACKED PASS-THROUGH CERTIFICATES, SERIES 2007-SP3, Plaintiff, vs.

SHANNON L. RAULERSON, ET AL., Defendant(s).

NOTICE OF SALE IS HEREBY GIVEN pursuant to a Uniform Final Judgment of Foreclosure dated March 16, 2016, and entered in Case No. 2015-CA-003790 of the Circuit Court of the 6th Judicial Circuit in and for Pasco County, Florida, wherein U.S. BANK NATIONAL ASSOCIATION, AS TRUSTEE, SUCCESSOR IN INTEREST TO BANK OF AMERICA, NATIONAL ASSOCIATION, AS TRUSTEE, SUCCESSOR BY MERGER TO LASALLE BANK NATIONAL ASSOCIATION, AS TRUSTEE FOR THE HOLDERS OF THE RAAC SERIES 2007-SP3 TRUST, MORTGAGE ASSET-BACKED PASS-THROUGH CERTIFICATES, SERIES 2007-SP3, is Plaintiff, and SHANNON L. RAULERSON, ET AL., are the Defendants, the Office of Paula S. O'Neil, Pasco County Clerk of the Court will sell to the highest and best bidder for cash via online auction at www.pasco.realforeclose.com at 11:00 A.M. on the 11th day of August, 2016, the following described property as set forth in said Final Judgment, to wit:

The South 398.00 feet of the West 1/2 of Tract 34, unrecorded Plat of New River Ranchettes Unit #1, subject to an easement for ingress and egress over and across the east 25 feet of the North 237.00 feet of the West 1/2 of said Tract 34, and subject to a road right of way for ingress and egress over and across the North 25 feet of said Tract 34, said

lands lying and being in Section 36, Township 20 South, Range 26 East, Pasco County, Florida, Said Tract 34 being more particularly described as follows; Commence at the Southwest corner of said Section 36, Township 20 South, Range 26 East, Pasco County, Florida, thence run East along the South line of said section 36, 2012.61 feet; thence North 1980.00 feet for a Point of Beginning; thence continue North 660.00 feet; thence East 330.00 feet; thence South 660.00 feet, thence West 330.00 feet to the Point of Beginning. Property Address: 1409 RATH-EL LANE, ZEPHYRHILLS, FLORIDA 33543

and all fixtures and personal property located therein or thereon, which are included as security in Plaintiff's mortgage.

Any person claiming an interest in the surplus funds from the sale, if any, other than the property owner as of the date of the lis pendens must file a claim within 60 days after the sale.

If you are a person with a disability who needs any accommodation in order to participate in this proceeding, you are entitled, at no cost to you, to the provision of certain assistance. Please contact the Public Information Dept., Pasco County Government Center, 7530 Little Rd., New Port Richey, FL 34654; (727) 847-8110 (V) in New Port Richey; (352) 521-4274, ext 8110 (V) in Dade City, at least 7 days before your scheduled court appearance, or immediately upon receiving this notification if the time before the scheduled appearance is less than 7 days; if you are hearing impaired call 711. The court does not provide transportation and cannot accommodate for this service. Persons with disabilities needing transportation to court should contact their local public transportation providers for information regarding transportation services.

Dated this 12th day of July, 2016.

By: Jared Lindsey, Esq.
FBN: 081974

Clarfield, Okon, Salomone & Pincus, P.L.
500 S. Australian Avenue,
Suite 730
West Palm Beach, FL 33401
Telephone: (561) 713-1400
Facsimile: (561) 713-1401
Email: pleadings@copslaw.com
July 15, 22, 2016 16-02024P

SECOND INSERTION

NOTICE OF ACTION IN THE CIRCUIT COURT FOR THE SIXTH JUDICIAL CIRCUIT IN AND FOR PASCO COUNTY, FLORIDA

CIRCUIT CIVIL DIVISION
CASE NO.: 2015 CA 004149
DITECH FINANCIAL LLC F/K/A GREEN TREE SERVICING LLC Plaintiff(s), vs.

THE UNKNOWN HEIRS, DEVISEES, GRANTEEES, ASSIGNEES, CREDITORS, LIENORS AND TRUSTEES OF DORIS PRISCILLA MAZEAU BARRY, DECEASED; VETERANS VILLAS III HOMEOWNERS ASSOCIATION, INC.; EUNICE HORAN, IF LIVING, BUT IF DECEASED, THE UNKNOWN HEIRS, DEVISEES, GRANTEEES, ASSIGNEES, CREDITORS, LIENORS AND TRUSTEES OF EUNICE HORAN; PASCO COUNTY, FLORIDA, CLERK OF COURT; DOUGLAS BARRY AKA DOUGLAS M. BARRY; THE UNKNOWN TENANT IN POSSESSION OF 2932 FORRESTAL CT. NEW PORT RICHEY, FL 34655; Defendant(s).

TO: THE UNKNOWN HEIRS, DEVISEES, GRANTEEES, ASSIGNEES, CREDITORS, LIENORS AND TRUSTEES OF DORIS PRISCILLA MAZEAU BARRY, DECEASED; EUNICE HORAN, IF LIVING, BUT IF DECEASED, THE UNKNOWN HEIRS, DEVISEES, GRANTEEES, ASSIGNEES, CREDITORS, LIENORS AND TRUSTEES OF EUNICE HORAN;

YOU ARE HEREBY NOTIFIED that a civil action has been filed against you in the Circuit Court of Pasco County, Florida, to foreclose certain real property described as follows:

Lot 147, Veterans Villas Phase Three as recorded in Plat Book 19, Pages 92 and 93, of the Public Records of Pasco County, Florida.

Property address: 2932 Forrestal Ct., New Port Richey, FL 34655 *on or before 8/15/16

You are required to file a written response with the Court and serve a copy of your written defenses, if any, to it on Timothy D. Padgett, P.A., whose address is 6267 Old Water Oak Road, Suite 203, Tallahassee, FL 32312, at least thirty (30) days from the date of first publication, and file the original with the clerk of this court either before service on Plaintiff's attorney or immediately thereafter; otherwise, a default will be entered against you for the relief demanded in the complaint.

If you are a person with a disability who needs any accommodation in order to participate in this proceeding, you are entitled, at no cost to you, to the provision of certain assistance. Please contact the Public Information Dept., Pasco County Government Center, 7530 Little Rd., New Port Richey, FL 34654; (727) 847-8110 (V) in New Port Richey; (352) 521-4274, ext 8110 (V) in Dade City, at least 7 days before your scheduled court appearance, or immediately upon receiving this notification if the time before the scheduled appearance is less than 7 days; if you are hearing impaired call 711. The court does not provide transportation and cannot accommodate for this service. Persons with disabilities needing transportation to court should contact their local public transportation providers for information regarding transportation services.

DATED this 7 day of July, 2016.
Paula S. O'Neil, Ph.D.,
Clerk & Comptroller
By: Carmella Hernandez
Deputy Clerk

Plaintiff Atty:
Timothy D. Padgett, P.A.
6267 Old Water Oak Road,
Suite 203
Tallahassee, FL 32312
attorney@padgettlaw.net
TDP File No. 15-001864-1
July 15, 22, 2016 16-02005P

SECOND INSERTION

NOTICE OF FORECLOSURE SALE PURSUANT TO CHAPTER 45 IN THE CIRCUIT COURT OF THE SIXTH JUDICIAL CIRCUIT IN AND FOR PASCO COUNTY, FLORIDA

CASE NO.: 2014CA001874CAAXES U.S. BANK TRUST, N.A., AS TRUSTEE FOR LSF8 MASTER PARTICIPATION TRUST, BY CALIBER HOME LOANS, INC., AS ITS ATTORNEY IN FACT, Plaintiff, vs.

CHRISTOPHER NECKER; et al., Defendant(s).
NOTICE IS HEREBY GIVEN that sale will be made pursuant to an Order or Final Judgment. Final Judgment was awarded on June 9, 2016 in Civil Case No. 2014CA001874CAAXES, of the Circuit Court of the SIXTH Judicial Circuit in and for Pasco County, Florida, wherein, U.S. BANK TRUST, N.A., AS TRUSTEE FOR LSF8 MASTER PARTICIPATION TRUST, BY CALIBER HOME LOANS, INC., AS ITS ATTORNEY IN FACT is the Plaintiff, and CHRISTOPHER NECKER; SOPHIA NECKER; UNKNOWN SPOUSE OF CHRISTOPHER NECKER; FOUNTAINS AT PARADISE LAKES CONDOMINIUM ASSOCIATION, INC.; ANY AND ALL UNKNOWN PARTIES CLAIMING BY, THROUGH, UNDER AND AGAINST THE HEREIN NAMED INDIVIDUAL DEFENDANT(S) WHO ARE NOT KNOWN TO BE DEAD OR ALIVE, WHETHER SAID UNKNOWN PARTIES MAY CLAIM AN INTEREST AS SPOUSES, HEIRS, DEVISEES, GRANTEEES, OR OTHER CLAIMANTS are Defendants.

The clerk of the court, Paula S. O'Neil, Ph.D will sell to the highest bidder for cash at www.pasco.realforeclose.com on August 8, 2016 at 11:00 AM, the following described real property as set forth in said Final Judgment, to wit:

UNIT 4203, THE FOUNTAINS AT PARADISE LAKES, A CONDOMINIUM, ACCORDING TO THAT CERTAIN DECLARATION OF CONDOMINIUM

FIELD JULY 12, 2001, IN OFFICIAL RECORDS BOOK 4665, PAGE 631, OF THE PUBLIC RECORDS OF PASCO COUNTY, FLORIDA, AS AMENDED; TOGETHER WITH THE EXHIBITS ATTACHED THERETO AND MADE A PART THEREOF AND TOGETHER WITH AN UNDIVIDED SHARE IN THE COMMON ELEMENTS APPURTENANT THERETO

ANY PERSON CLAIMING AN INTEREST IN THE SURPLUS FROM THE SALE, IF ANY, OTHER THAN THE PROPERTY OWNER AS OF THE DATE OF THE LIS PENDENS MUST FILE A CLAIM WITHIN 60 DAYS AFTER THE SALE.

IMPORTANT AMERICANS WITH DISABILITIES ACT: If you are a person with a disability who needs an accommodation in order to participate in this proceeding, you are entitled, at no cost to you, to the provision of certain assistance. Please contact: Public Information Dept., Pasco County Government Center, 7530 Little Rd., New Port Richey, FL 34654; Phone: 727.847.8110 (voice) in New Port Richey, 352.521.4274, ext 8110 (voice) in Dade City, Or 711 for the hearing impaired. Contact should be initiated at least seven days before the scheduled court appearance, or immediately upon receiving this notification if the time before the scheduled appearance is less than seven days.

Dated this 12 day of July, 2016.

By: Susan Sparks
FBN: 33626
for Susan W. Findley, Esq.
FBN: 160600
Primary E-Mail:
ServiceMail@aldridgepите.com

ALDRIDGE | PITE, LLP
Attorney for Plaintiff
1615 South Congress Avenue Suite 200
Delray Beach, FL 33445
Telephone: (844) 470-8804
Facsimile: (561) 392-6965
1091-9837B
July 15, 22, 2016 16-02035P

SECOND INSERTION

NOTICE OF FORECLOSURE SALE IN THE CIRCUIT COURT OF THE SIXTH JUDICIAL CIRCUIT OF FLORIDA IN AND FOR PASCO COUNTY GENERAL JURISDICTION DIVISION

CASE NO. 2012-CA-007016-WS FLAGSTAR BANK, FSB, Plaintiff, vs.

AARON MITCHELL, ET AL., Defendants.
NOTICE IS HEREBY GIVEN pursuant to a Summary Final Judgment of Foreclosure entered March 14, 2014 in Civil Case No. 2012-CA-007016-WS of the Circuit Court of the SIXTH Judicial Circuit in and for Pasco County, Dade City, Florida, wherein FLAGSTAR BANK, FSB is Plaintiff and AARON MITCHELL, ET AL., are Defendants, the Clerk of Court will sell to the highest and best bidder for cash electronically at www.pasco.realforeclose.com in accordance with Chapter 45, Florida Statutes on the 11TH day of August, 2016 at 11:00 AM on the following described property as set forth in said Summary Final Judgment, to-wit:

Lot 27, ORCHID LAKE VILLAGE UNIT ONE, according to the map or plat thereof, as recorded in Plat Book 17, Page 64, of the Public Records of Pasco County, Florida.

Any person claiming an interest in the surplus from the sale, if any, other than the property owner as of the date of the lis pendens, must file a claim within 60 days after the sale.

If you are a person with a disability who needs any accommodation in order to participate in this proceeding, you are entitled, at no cost to you to the provision of certain assistance. Within two (2) working days of your receipt of this (describe notice/order) please contact the Public Information Dept., Pasco County Government Center, 7530 Little Rd., New Port Richey, FL 34654; (727) 847-8110 (V) in New Port Richey; (352) 521-4274, ext. 8110 (V) in Dade City; via 1-800-955-8771 if you are hearing impaired. The court does not provide transportation and cannot accommodate for this service. Persons with disabilities needing transportation to court should contact their local public transportation providers for information regarding disabled transportation services.

Lisa Woodburn, Esq.
Fla. Bar No.: 11003

McCalla Raymer Pierce, LLC
Attorney for Plaintiff
225 E. Robinson St. Suite 155
Orlando, FL 32801
Phone: (407) 674-1850
Fax: (321) 248-0420
Email:
MRService@mccallaraymer.com
5043828
12-01665-5
July 15, 22, 2016 16-02037P

SECOND INSERTION

NOTICE OF ACTION IN THE SIXTH JUDICIAL CIRCUIT OF THE SIXTH JUDICIAL CIRCUIT IN AND FOR PASCO COUNTY, FLORIDA.

CIVIL DIVISION
CASE NO. 512015CA000862CAAXES/J1

WILMINGTON SAVINGS FUND SOCIETY FSB, D/B/A CHRISTIANA TRUST, NOT INDIVIDUALLY BUT AS TRUSTEE FOR PRETIUM MORTGAGE ACQUISITION TRUST, Plaintiff, vs.

KEVORK K. DEMIRJIAN; et al; Defendants.
TO: MARISOL DEMIRJIAN A/K/A MARISOL L. DEMIRIAN Last Known Address 1129 CONCH CT WESLEY CHAPEL, FL 33543

Current Residence is Unknown
YOU ARE NOTIFIED that an action to foreclose a mortgage on the following described property in Pasco County, Florida:

Lot 1, Block A, NORTHWOOD UNIT 1, as per plat thereof, recorded in Plat Book 32, Pages 69 through 77, of the Public Records of Paco County, Florida.

has been filed against you and you are required to serve a copy of your written defenses, if any, to it on SHD Legal Group P.A., Plaintiff's attorneys, whose address is PO BOX 19519 Fort Lauderdale, FL 33318, (954) 564-0071, answers@shdlegalgroup.com, on or before AUG 15 2016, and file the original with the Clerk of this Court either before service on Plaintiff's attorneys or immediately thereafter; otherwise a default will be entered against you for the relief demanded in the complaint or petition.

In accordance with the Americans with Disabilities Act of 1990, persons needing special accommodation to participate in this proceeding should contact the Clerk of the Court not later than five business days prior to the proceeding at the Pasco County Courthouse. Telephone 352-521-4545 (Dade City) 352-847-2411 (New Port Richey) or 1-800-955-8770 via Florida Relay Service.

DATED on July 11, 2016.

Paula S. O'Neil, Ph.D.,
Clerk & Comptroller
As Clerk of the Court
By: Gerald Salgado
As Deputy Clerk

SHD Legal Group P.A.
Plaintiff's attorneys
PO BOX 19519
Fort Lauderdale, FL 33318
(954) 564-0071
answers@shdlegalgroup.com
1460-157883 ANF
July 15, 22, 2016 16-02025P

SECOND INSERTION

NOTICE OF FORECLOSURE SALE IN THE CIRCUIT COURT OF THE SIXTH JUDICIAL CIRCUIT OF FLORIDA IN AND FOR PASCO COUNTY GENERAL JURISDICTION DIVISION

CASE NO. 51-2015-CA-003754-WS SPECIALIZED LOAN SERVICING LLC, Plaintiff, vs.

DENNIS M. DARRAGH, ET AL., Defendants.

NOTICE IS HEREBY GIVEN pursuant to a Summary Final Judgment of Foreclosure entered May 11, 2016 in Civil Case No. 51-2015-CA-003754-WS of the Circuit Court of the SIXTH Judicial Circuit in and for Pasco County, Dade City, Florida, wherein SPECIALIZED LOAN SERVICING LLC is Plaintiff and DENNIS M. DARRAGH, ET AL., are Defendants, the Clerk of Court will sell to the highest and best bidder for cash electronically at www.pasco.realforeclose.com in accordance with Chapter 45, Florida Statutes on the 10TH day of August, 2016 at 11:00 AM on the following described property as set forth in said Summary Final Judgment, to-wit:

Lot 124, LAKESIDE WOODLANDS SECTION I, according to the plat thereof, as the same is recorded in Plat Book 16, Pages 92 and 93, inclusive, of the Public Records of Pasco County, Florida.

Any person claiming an interest in the surplus from the sale, if any, other than the property owner as of the date of the lis pendens, must file a claim within 60 days after the sale.

If you are a person with a disability who needs any accommodation in order to participate in this proceeding, you are entitled, at no cost to you to the provision of certain assistance. Within two (2) working days of your receipt of this (describe notice/order) please contact the Public Information Dept., Pasco County Government Center, 7530 Little Rd., New Port Richey, FL 34654; (727) 847-8110 (V) in New Port Richey; (352) 521-4274, ext. 8110 (V) in Dade City; via 1-800-955-8771 if you are hearing impaired. The court does not provide transportation and cannot accommodate for this service. Persons with disabilities needing transportation to court should contact their local public transportation providers for information regarding disabled transportation services.

Lisa Woodburn, Esq.
Fla. Bar No.: 11003

McCalla Raymer Pierce, LLC
Attorney for Plaintiff
225 E. Robinson St. Suite 155
Orlando, FL 32801
Phone: (407) 674-1850
Fax: (321) 248-0420
Email:
MRService@mccallaraymer.com
5043766
15-04182-2
July 15, 22, 2016 16-02038P

SECOND INSERTION

NOTICE OF SALE IN THE COUNTY COURT OF THE SIXTH JUDICIAL CIRCUIT IN AND FOR PASCO COUNTY, FLORIDA CIVIL DIVISION

CASE NO.: 51-2015-CC-000160-ES CHAPEL PINES HOMEOWNERS ASSOCIATION, INC., Plaintiff, v.

RHODA V. EASLEY, A SINGLE WOMAN, Defendant.

NOTICE IS GIVEN that pursuant to the Order Resetting Foreclosure Sale, entered in this action on the 29th day of June, 2016, Paula S. O'Neil, Ph. D., Clerk of Court for Pasco County, Florida, will sell to the highest and best bidder or bidders for cash at http://www.pasco.realforeclose.com, on August 11, 2016 at 11:00 A.M., the following described property:

LOT 42, BLOCK M, CHAPEL PINES-PHASE 3, ACCORDING TO THE PLAT THEREOF, AS RECORDED IN PLAT BOOK 48 AT PAGES 85 THROUGH 88, INCLUSIVE OF THE PUBLIC RECORDS OF PASCO COUNTY, FLORIDA.

and improvements thereon, located in the Chapel Pines community at 6553 Tabogi Trail, Wesley Chapel, Florida 33545 (the "Property"). Any person claiming an interest in the surplus, if any, from the judicial sale of the Property, other than the Property owner, as of the date of the Notice of Lis Pendens, must file a claim within sixty (60) days after the judicial sale of the Property.

If you are a person with a disability who needs any accommodation in order to participate in this proceeding, you are entitled, at no cost to you, to the provision of certain assistance. Within two (2) working days of your receipt of this (describe notice/order) please contact the Public Information Dept., Pasco County Government Center, 7530 Little Rd., New Port Richey, FL 34654; (727) 8478110 (V) in New Port Richey; (352) 521-4274, ext. 8110 (V) in Dade City; via 1-800-955-8771 if you are hearing impaired. The court does not provide transportation and cannot accommodate for this service. Persons with disabilities needing transportation to court should contact their local public transportation providers for information regarding disabled transportation services.

By: JONATHAN J. ELLIS, ESQ.
Florida Bar No. 863513
JASON W. DAVIS, ESQ.
Florida Bar No. 84952

Primary Email: jdavis@slk-law.com
Secondary Email: mschwalbach@slk-law.com
SHUMAKER, LOOP & KENDRICK, LLP
Post Office Box 172609
Tampa, Florida 33672-0609
Telephone: (813) 229-7600
Facsimile: (813) 229-1660
Counsel for Plaintiff
SLK_TAM#2556574v1
July 15, 22, 2016 16-02041P

SECOND INSERTION

NOTICE OF FORECLOSURE SALE IN THE CIRCUIT COURT OF THE SIXTH JUDICIAL CIRCUIT OF FLORIDA IN AND FOR PASCO COUNTY GENERAL JURISDICTION DIVISION

CASE NO. 2013-CA-005358-ES JPMORGAN CHASE BANK, NATIONAL ASSOCIATION, Plaintiff, vs.

NICHOLAS GRASSI, ET AL., Defendants.

NOTICE IS HEREBY GIVEN pursuant to a Summary Final Judgment of Foreclosure entered March 16, 2016 in Civil Case No. 2013-CA-005358-ES of the Circuit Court of the SIXTH Judicial Circuit in and for Pasco County, Dade City, Florida, wherein JPMORGAN CHASE BANK, NATIONAL ASSOCIATION is Plaintiff and NICHOLAS GRASSI, ET AL., are Defendants, the Clerk of Court will sell to the highest and best bidder for cash electronically at www.pasco.realforeclose.com in accordance with Chapter 45, Florida Statutes on the 4TH day of August, 2016 at 11:00 AM on the following described property as set forth in said Summary Final Judgment, to-wit:

Lot 37, Block 9, DUPREE LAKES PHASE 1, according to the map or plat thereof, as recorded in Plat Book 54, Page(s) 62 through 87, inclusive, of the Public Records of Pasco County, Florida.

Any person claiming an interest in the surplus from the sale, if any, other than the property owner as of the date of the lis pendens, must file a claim within 60 days after the sale.

If you are a person with a disability who needs any accommodation in order to participate in this proceeding, you are entitled, at no cost to you to the provision of certain assistance. Within two (2) working days of your receipt of this (describe notice/order) please contact the Public Information Dept., Pasco County Government Center, 7530 Little Rd., New Port Richey, FL 34654; (727) 847-8110 (V) in New Port Richey; (352) 521-4274, ext. 8110 (V) in Dade City; via 1-800-955-8771 if you are hearing impaired. The court does not provide transportation and cannot accommodate for this service. Persons with disabilities needing transportation to court should contact their local public transportation providers for information regarding disabled transportation services.

Lisa Woodburn, Esq.
Fla. Bar No.: 11003

McCalla Raymer Pierce, LLC
Attorney for Plaintiff
225 E. Robinson St. Suite 155
Orlando, FL 32801
Phone: (407) 674-1850
Fax: (321) 248-0420
Email:
MRService@mccallaraymer.com
5043879
13-07693-3
July 15, 22, 2016 16-02039P

SECOND INSERTION

NOTICE OF FORECLOSURE SALE IN THE CIRCUIT COURT OF THE SIXTH JUDICIAL CIRCUIT, IN AND FOR PASCO COUNTY, FLORIDA.

CASE No. 51-2012-CA-005868-CAAX-ES U.S. NATIONAL ASSOCIATION, AS TRUSTEE FOR J.P. MORGAN MORTGAGE ACQUISITION TRUST 2006-WMC4, ASSET BACKED PASS-THROUGH CERTIFICATES, SERIES 2006-WMC4, PLAINTIFF, VS.

BARBARA A JONES, ET AL. DEFENDANT(S).

NOTICE IS HEREBY GIVEN pursuant to the Final Judgment of Foreclosure dated February 11, 2015 in the above action, the Pasco County Clerk of Court will sell to the highest bidder for cash at Pasco, Florida, on September 19, 2016, at 11:00 AM, at www.pasco.realforeclose.com for the following described property:

Lot 67, Wesley Pointe Phases 2 & 3, according to the Plat thereof, recorded in Plat Book 38, Pages 27, 28 and 29, Public Records of Pasco County, Florida

Any person claiming an interest in the surplus from the sale, if any, other than the property owner as of the date of the lis pendens must file a claim within sixty (60) days after the sale. The Court, in its discretion, may enlarge the time of the sale. Notice of the changed time of sale shall be published as provided herein.

If you are a person with a disability who needs any accommodation in order to participate in this proceeding, you are entitled, at no cost to you, to the provision of certain assistance. Please contact the Public Information Department at 727-847-8110 in New Port Richey or 352-521-4274, extension 8110 in Dade City or at Pasco County Government Center, 7530 Little Road, New Port Richey, FL 34654 at least 7 days before your scheduled court appearance, or immediately upon receiving this notification if the time before the scheduled appearance is less than 7 days; if you are hearing or voice impaired, call 711.

The court does not provide transportation and cannot accommodate such requests. Persons with disabilities needing transportation to court should contact their local public transportation providers for information regarding transportation services.

By: Allen Katz, Esq.
FBN 87866

Gladstone Law Group, P.A.
Attorney for Plaintiff
1499 W. Palmetto Park Road,
Suite 300
Boca Raton, FL 33486
Telephone #: 561-338-4101
Fax #: 561-338-4077
Email:
eservice@gladstonelawgroup.com
Our Case #: 14-002340-FIH
July 15, 22, 2016 16-01985P

Hillsborough & Pasco Counties
P: (813) 221-9505 F: (813) 221-9403

SECOND INSERTION

RE-NOTICE OF SALE
PURSUANT TO CHAPTER 45
IN THE CIRCUIT COURT FOR THE
6th JUDICIAL CIRCUIT IN AND
FOR PASCO COUNTY, FLORIDA
CASE NO.:

51-2012-CA-003524 ES
U.S. BANK NATIONAL
ASSOCIATION, AS TRUSTEE
UNDER THE POOLING AND
SERVICING AGREEMENT DATED
AS OF AUGUST 1, 2006 MASTR
ASSET-BACKED SECURITIES
TRUST 2006-HE3, MORTGAGE
PASS-THROUGH CERTIFICATES,
SERIES 2006-HE3,
Plaintiff(s), vs.
ANTHONY G. TAMARGO; et al.,
Defendant(s).

NOTICE OF SALE IS HEREBY
GIVEN pursuant to a Final Judgment
of Foreclosure dated June 24,
2015, and entered in Case No. 51-
2012-CA-003524 ES of the Circuit
Court of the 6th Judicial Circuit
in and for Pasco County, Florida,
wherein U.S. BANK NATIONAL
ASSOCIATION, AS TRUSTEE UNDER
THE POOLING AND SERVICING
AGREEMENT DATED AS OF AUGUST 1,
2006 MASTR ASSET-BACKED
SECURITIES TRUST 2006-HE3,
MORTGAGE PASS-THROUGH
CERTIFICATES, SERIES 2006-HE3, is
Plaintiff, and ANTHONY G. TAMARGO;
et al., are the Defendants, the Office
of Paula S. O'Neil, Pasco County Clerk
of the Court will sell to the highest
and best bidder for cash via online
auction at www.pasco.realforeclose.
com at 11:00 A.M. on the 9th day
of August, 2016, the following
described property as set forth in said
Final Judgment, to wit:

The South 1/2 of the following
described land: Tract 96 of the
unrecorded plat of WESLEY
CHAPEL ACRES, more particularly
described as follows:
Commencing at the Southwest
corner of the Northwest 1/4 of
Section 6, Township 26 South,
Range 20 East, Pasco County,

Florida, run South 00 degrees
01'54" West, 256.51 feet along the
West boundary of said Section 6;
thence run North 41 degrees
46'12" East, 1039.55 feet;
thence run North 52 degrees
34'57" East, 1097.7 feet; thence
run North 54 degrees 36'57"
East, 1384.61 feet; thence run
North 79 degrees 14'33" West,
133.37 feet; thence run North
13 degrees 12'52" East, 349.09
feet; thence run South 76 de-
grees 40'19" East, 133.37 feet;
thence run South 13 degrees
14'06" West, 343.42 feet to the
POINT OF BEGINNING; SUB-
JECT TO AN EASEMENT OVER AND
ACROSS the Southerly 25.0 feet
thereof for DEEDRA DRIVE.
The South 1/2 of the following
described land: Tract 97 of the
unrecorded plat of WESLEY
CHAPEL ACRES. More particularly
described as follows:
Commencing at the Southwest
corner of the Northwest 1/4 of
Section 6, Township 26 South,
Range 20 East, Pasco County,
Florida, run South 00 degrees
01'54" West, 256.51 feet along the
West boundary of said Section 6;
thence run North 41 degrees
46'12" East, 1039.55 feet; thence
run North 52 degrees 34'57" East,
1097.7 feet; thence run North
54 degrees 36'57" East, 1384.61
feet; thence run North 79 de-
grees 14'33" West, 400.12 feet
for a POINT OF BEGINNING;
thence continue North 79 de-
grees 14'33" West, 133.38 feet;
thence run North 13 degrees 11'
41" East, 354.77 feet; thence run
South 76 degrees 48'19" East,
133.38 feet; thence run South 13
degrees 12'52" West, 349.09 feet
to the POINT OF BEGINNING;
SUBJECT TO AN EASEMENT OVER
AND ACROSS the Southerly
25.0 feet thereof for DEEDRA

DRIVE and the Westerly 25.0
feet thereof for CLINTON WAY.
TOGETHER WITH easement
for ingress and Egress to and
from the above described prop-
erty
Property Address: 28419 Deedra
Drive, Zephyrhills, FL 33544
and all fixtures and personal property
located therein or thereon, which are
included as security in Plaintiff's mort-
gage.

Any person claiming an interest in
the surplus funds from the sale, if any,
other than the property owner as of the
date of the lis pendens must file a claim
within 60 days after the sale.

If you are a person with a disability
who needs any accommodation in order
to participate in this proceeding, you are
entitled, at no cost to you, to the
provision of certain assistance. Please
contact the Public Information
Dept., Pasco County Govern-
ment Center, 7530 Little Rd., New
Port Richey, FL 34654; (727) 847-
8110 (V) in New Port Richey; (352)
521-4274, ext 8110 (V) in Dade City,
at least 7 days before your scheduled
court appearance, or immediately
upon receiving this notification if the
time before the scheduled appearance
is less than 7 days; if you are hearing
impaired call 711. The court does not
provide transportation and cannot ac-
commodate for this service. Persons
with disabilities needing transporta-
tion to court should contact their local
public transportation providers for
information regarding transportation
services.

Dated this 11th day of July, 2016.

By: Jared Lindsey, Esq.
FBN: 081974

Clarfield, Okon, Salomone
& Pincus, P.L.
Attorney for Plaintiff
500 S. Australian Avenue,
Suite 730
West Palm Beach, FL 33401
Telephone: (561) 713-1400
Facsimile: (561) 713-1401
Email: pleadings@copslaw.com
July 15, 22, 2016 16-02023P

SECOND INSERTION

NOTICE TO CREDITORS
(Summary Administration)
IN THE CIRCUIT COURT FOR
PASCO COUNTY, FLORIDA
PROBATE DIVISION
File No. 2016-CP-000871
Division I
IN RE: ESTATE OF
WALTER GIDEON JAMBECK, SR.,
Deceased.
TO ALL PERSONS HAVING CLAIMS
OR DEMANDS AGAINST THE
ABOVE ESTATE:

You are hereby notified that an Order
of Summary Administration has
been entered in the estate of WALTER
GIDEON JAMBECK, SR., deceased,
File Number 2016-CP-000871, by the
Circuit Court for Pasco County, Florida,
Probate Division, the address of
which is Clerk and Comptroller, 38053
Live Oak Avenue, Suite 207, Dade
City, Florida 33523-3894; that the
decedent's date of death was April 13,
2016; that the total value of the estate
is \$44,333.00 and that the names and
addresses of those to whom it has been
assigned by such order are:

Name MICHAEL J. STEVENS as
TRUSTEE OF THE WALTER G. JAM-
BECK REVOCABLE INTER-VIVOS
TRUST AGREEMENT DATED NO-
VEMBER 28, 2006

Address 7424 W. Opal Lake Road
Gaylord, Michigan 49735
ALL INTERESTED PERSONS ARE
NOTIFIED THAT:

All creditors of the estate of the
decedent and persons having claims
or demands against the estate of the
decedent other than those for whom
provision for full payment was made
in the Order of Summary Administra-
tion must file their claims with this
court WITHIN THE TIME PERIODS
SET FORTH IN SECTION 733.702
OF THE FLORIDA PROBATE CODE.
ALL CLAIMS AND DEMANDS NOT
SO FILED WILL BE FOREVER
BARRED. NOTWITHSTANDING
ANY OTHER APPLICABLE TIME
PERIOD, ANY CLAIM FILED TWO
(2) YEARS OR MORE AFTER THE
DECEDENT'S DATE OF DEATH IS
BARRED.

The date of first publication of this
Notice is July 15, 2016.

Personal Giving Notice:
MICHAEL J. STEVENS
PO Box 2248
Gaylord, Michigan 49734
Attorney for Personal Giving Notice:
Alison E. Hickman
Attorney for MICHAEL J. STEVENS
Florida Bar Number: 085048
Grady H Williams, Jr., LL.M.,
Attorneys at Law, P.A.
1543 Kingsley Avenue, Building 5
Orange Park, FL 32073
Telephone: (904) 264-8800
Fax: (904) 264-0155
Primary Designated Service E-Mail:
alison@floridaelder.com
Secondary Designated Service E-mail:
donna@floridaelder.com
July 15, 22, 2016 16-01984P

SECOND INSERTION

NOTICE OF ACTION
IN THE CIRCUIT COURT OF THE
SIXTEENTH JUDICIAL CIRCUIT
IN AND FOR PASCO COUNTY,
FLORIDA
CASE NO.: 2016CA001765CAAXWS
WELLS FARGO BANK, N.A.,
Plaintiff, vs.
DEBORAH HORMERTE, P.O. BOX
652, PORT RICHEY, FLORIDA AS
TRUSTEE.....; et al.,
Defendant(s).
TO: UNKNOWN BENEFICIARIES
OF THE TRUST NUMBER 2250
Last Known Residence: UNKNOWN
YOU ARE HEREBY NOTIFIED that
an action to foreclose a mortgage on
the following property in Pasco County,
Florida:

TRACT 11 OF GOLDEN ACRES
UNIT ELEVEN, AS PER PLAT
THEREOF RECORDED IN
PLAT BOOK 15, PAGE 84,85,86
AND 87 OF THE PUBLIC RE-
CORDS OF PASCO COUNTY
FLORIDA.

has been filed against you and you are
required to serve a copy of your written
defenses, if any, to an ALDRIDGE |
PITE, LLP, Plaintiff's attorney, at 1615
South Congress Avenue, Suite 200,
Delray Beach, FL 33445 (Phone Num-
ber: (561) 392-6391), within 30 days
of the first date of publication of this
notice, and file the original with the
clerk of this court either before 8/15/16
on Plaintiff's attorney or immediately
thereafter; otherwise a default will be
entered against you for the relief de-
manded in the complaint or petition.

If you are a person with a disability
who needs any accommodation in order
to participate in this proceeding, you are
entitled, at no cost to you, to the
provision of certain assistance. Please
contact the Public Information
Dept., Pasco County Government
Center, 7530 Little Rd., New Port Richey,
FL 34654; (727) 847-8110 (V) in New
Port Richey; (352) 521-4274, ext 8110
(V) in Dade City, at least 7 days before
your scheduled court appearance, or
immediately upon receiving this notifi-
cation if the time before the scheduled
appearance is less than 7 days; if you
are hearing impaired call 711. The court
does not provide transportation and
cannot accommodate for this service.
Persons with disabilities needing trans-
portation to court should contact their
local public transportation providers
for information regarding transporta-
tion services.

Dated on July 7, 2016.
Paula S. O'Neil, Ph.D.,
Clerk & Comptroller
By: Carmella Hernandez
As Deputy Clerk
ALDRIDGE | PITE, LLP
Plaintiff's attorney
1615 South Congress Avenue,
Suite 200
Delray Beach, FL 33445
(Phone Number: (561) 392-6391)
1113-752470B
July 15, 22, 2016 16-02006P

SECOND INSERTION

NOTICE OF FORECLOSURE SALE
IN THE CIRCUIT COURT OF THE
SIXTH JUDICIAL CIRCUIT IN AND
FOR PASCO COUNTY, FLORIDA
CASE NO.: 51-2012-CA-003830-WS
BANK OF AMERICA, NATIONAL
ASSOCIATION,
Plaintiff, -vs.-
UNKNOWN HEIRS AND/OR
BENEFICIARIES OF THE ESTATE
OF WILLIAM PHILLIPS A/K/A
WILLIAM PHILLIPS; JUDY
FELDKAMP, et al,
Defendant(s).

NOTICE IS HEREBY GIVEN pursuant
to the Final Judgment of Foreclosure
dated June 2, 2016, in the above action.
Paula S. O'Neil, the Pasco County Clerk
of Court will sell to the highest bidder
for cash at Pasco, Florida, on August
3, 2016, at 11:00 a.m., at www.pasco.
realforeclose.com for the following de-
scribed property:

LOT 238, ORCHID LAKE VIL-
LAGE, UNIT TWO, AS SHOWN
ON PLAT RECORDED IN PLAT
BOOK 18, PAGES 106 THROUGH
109 OF THE PUBLIC RECORDS
OF PASCO COUNTY, FLORIDA
PROPERTY ADDRESS: 6932
Pin Cherry Lane, Port Richey, FL
34668.

Any person claiming an interest in the
surplus from the sale, if any, other than
the property owner as of the date of the
lis pendens must file a claim within six-
ty (60) days after the sale. The Court,
in its discretion, may enlarge the time
of the sale. Notice of the changed time
of sale shall be published as provided
herein.

If you are a person with a disability
who needs any accommodation in order
to participate in this proceeding, you are
entitled, at no cost to you, to the
provision of certain assistance. Please
contact the Public Information Depart-
ment at 727-847-8110 (V) in New Port
Richey or 352-521-4274, extension 8110
(V) in Dade City or at Pasco County
Government Center, 7530 Little Road,
New Port Richey, FL 34654 at least 7
days before your scheduled court ap-
pearance, or immediately upon receiv-
ing this notification if the time before
the scheduled appearance is less than
7 days; if you are hearing or voice im-
paired, call 711. The court does not
provide transportation and cannot ac-
commodate such requests. Persons with
disabilities needing transportation to
court should contact their local public
transportation providers for informa-
tion regarding transportation services.

Galina Boytchev, Esq.
FBN: 47008
Ward, Damon, Posner,
Pheterson & Bleau PL
Attorney for Plaintiff
4420 Beacon Circle
West Palm Beach, FL 33407
Tel: (561) 842-3000
Fax: (561) 842-3626
Email:
foreclosureservice@warddameron.com
July 15, 22, 2016 16-02014P

SECOND INSERTION

NOTICE TO CREDITORS
IN THE CIRCUIT COURT OF THE
SIXTH JUDICIAL CIRCUIT IN AND
FOR PASCO COUNTY, FLORIDA
PROBATE DIVISION
FILE NO. : 2016-CP-000462-ES
IN RE: ESTATE OF
RUTH ANN KAY,
Deceased.

TO ALL PERSONS HAVING CLAIMS
OR DEMANDS AGAINST THE
ABOVE ESTATE:

The administration of the estate of
RUTH ANN KAY, deceased, File Num-
ber 2016-CP-000462-ES, is pending in
the Circuit Court of Pasco County, Florida,
Probate Division, the address of
which is 38053 Live Oak Avenue Dade
City, FL 33523-3894. The names and
addresses of the personal Representa-
tive and the personal representative's
attorney are set forth below.

ALL INTERESTED PERSON ARE
NOTIFIED THAT:

All creditors of the decedent and oth-
er persons having claims or demands
against decedent's estate, including
unmatured, contingent or unliquidated
claims, on whom a copy of this notice
is served must file their claims with
this Court WITHIN THE LATER OF
THREE MONTHS AFTER THE DATE
OF THE FIRST PUBLICATION OF
THIS NOTICE OR THIRTY DAYS AFTER
THE DATE OF SERVICE OF A
COPY OF THIS NOTICE ON THEM.

All other creditors of the decedent
and persons having claims or demands
against decedent's estate, including un-
matured, contingent or unliquidated
claims, must file their claims with this
Court WITHIN THREE MONTHS
AFTER THE DATE OF THE FIRST
PUBLICATION OF THIS NOTICE.

ALL CLAIMS AND DEMANDS
NOT SO FILED WILL BE FOREVER
BARRED.

The date of first publication of this
Notice is July 15, 2016.

JAMES WILLIAM KAY,
1023 Sawyers Court
Lutz, FL 33559
Frank G. Finkbeiner, Attorney
Florida Bar No. 146738
108 Hillcrest Street
P.O. Box 1789
Orlando, FL 32802-1789
(407) 423-0012
Attorney for Petitioner
Primary: frank@fgfatlaw.com
Secondary: Sharon@fgfatlaw.com
July 15, 22, 2016 16-02045P

SECOND INSERTION

NOTICE OF FORECLOSURE SALE
IN THE CIRCUIT COURT OF THE
SIXTH JUDICIAL CIRCUIT OF
FLORIDA IN AND FOR
PASCO COUNTY
GENERAL JURISDICTION
DIVISION

CASE NO. 2014-CA-3840 WS
NATIONSTAR MORTGAGE LLC,
Plaintiff, vs.
GARY MCCARTHY, ET AL.,
Defendants.

NOTICE IS HEREBY GIVEN pursuant
to a Summary Final Judgment of
Foreclosure entered May 11, 2016 in
Civil Case No. 2014-CA-3840 WS of
the Circuit Court of the SIXTH Judi-
cial Circuit in and for Pasco County,
Dade City, Florida, wherein NATION-
STAR MORTGAGE LLC is Plaintiff
and GARY MCCARTHY, ET AL., are
Defendants, the Clerk of Court will sell
to the highest and best bidder for cash
electronically at www.pasco.realfore-
close.com in accordance with Chapter
45, Florida Statutes on the 10TH day
of August, 2016 at 11:00 AM on the fol-
lowing described property as set forth
in said Summary Final Judgment, to-
wit:

Lot 59, Sea Pines Subdivision,
Unit Three, according to the
map or plat thereof as recorded
in Plat Book 10, Pages 8 and 9,
of the Public Records of Pasco
County, Florida.

Any person claiming an interest in the
surplus from the sale, if any, other than
the property owner as of the date of the
lis pendens, must file a claim within 60
days after the sale.

If you are a person with a disability
who needs any accommodation in order
to participate in this proceeding, you are
entitled, at no cost to you, to the pro-
vision of certain assistance. Within two
(2) working days of your receipt of this
(describe notice/order) please contact
the Public Information Dept., Pasco
County Government Center, 7530 Little
Rd., New Port Richey, FL 34654; (727)
847-8110 (V) in New Port Richey; (352)
521-4274, ext. 8110 (V) in Dade City;
via 1-800-955-8771 if you are hearing
impaired. The court does not provide
transportation and cannot accommo-
date for this service. Persons with
disabilities needing transportation to
court should contact their local public
transportation providers for informa-
tion regarding disabled transportation
services.

Lisa Woodburn, Esq.
Fla. Bar No.: 11003
McCalla Raymer Pierce, LLC
Attorney for Plaintiff
225 E. Robinson St. Suite 155
Orlando, FL 32801
Phone: (407) 674-1850
Fax: (321) 248-0420
Email:
MRSservice@mccallaraymer.com
5041210
14-06851-3
July 15, 22, 2016 16-02040P

SECOND INSERTION

NOTICE OF FORECLOSURE SALE
IN THE CIRCUIT COURT OF THE
6TH JUDICIAL CIRCUIT, IN AND
FOR PASCO COUNTY, FLORIDA
CIVIL DIVISION:
CASE NO.:

51-2013-CA-003024-ES -
FEDERAL NATIONAL MORTGAGE
ASSOCIATION,
Plaintiff, vs.

KENNETH ANDERSON A/K/A
KENNETH R ANDERSON A/K/A
KENNETH RAY ANDERSON;
REBECCA OAKES; UNKNOWN
SPOUSE OF KENNETH
ANDERSON A/K/A KENNETH R
ANDERSON AK/A KENNETH RAY
ANDERSON; UNKNOWN SPOUSE
OF REBECCA OAKES; UNKNOWN
TENANT IN POSSESSION OF THE
SUBJECT PROPERTY,
Defendants.

NOTICE IS HEREBY GIVEN pursuant
to Final Judgment of Foreclosure dated
the 8th day of June 2016 and entered in
Case No. 51-2013-CA-003024-ES -, of
the Circuit Court of the 6TH Judicial
Circuit in and for Pasco County, Florida,
wherein FEDERAL NATIONAL
MORTGAGE ASSOCIATION is the
Plaintiff and KENNETH ANDERSON
A/K/A KENNETH R ANDERSON
A/K/A KENNETH RAY ANDERSON;
REBECCA OAKES; UNKNOWN
SPOUSE OF KENNETH ANDERSON
A/K/A KENNETH R ANDERSON
AK/A KENNETH RAY ANDERSON;
UNKNOWN SPOUSE OF REBECCA
OAKES; HARVEST CREDIT MAN-
AGEMENT, VII AS ASSIGNEE OF
BARCLAYS - AIRTRAN AIRWAYS;
and UNKNOWN TENANT(S) IN POS-
SESSION OF THE SUBJECT PROP-
ERTY are defendants. The Clerk of this
Court shall sell to the highest and best
bidder for cash, on the 1st day of August
2016 at 11:00 AM on Pasco County's
Public Auction website: www.pasco.re-
alforeclose.com, pursuant to judgment
or order of the Court, in accordance
with Chapter 45, Florida Statutes, the
following described property as set
forth in said Final Judgment, to wit:

ANGUS VALLEY UNIT 3, LOT
1157;
A TRACT OF LAND LYING
IN SECTION 2, TOWNSHIP
26 SOUTH, RANGE 19 EAST,
PASCO COUNTY, FLORIDA,
MORE PARTICULARLY DE-
SCRIBED AS FOLLOWS:
BEGIN AT THE SOUTHWEST
CORNER OF THE STATED
SECTION 2, THENCE RUN
EAST (ASSUMED BEAR-

ING) ALONG THE SOUTH
BOUNDARY OF THE STATED
SECTION 2, A DISTANCE
OF 2711.25 FEET; THENCE
NORTH A DISTANCE OF
4640.42 FEET FOR A POINT
OF BEGINNING. THENCE
WEST, A DISTANCE OF 213.25
FEET; THENCE NORTH
16°06'17" EAST, A DISTANCE
OF 271.52 FEET; THENCE
SOUTH 66° 51'42" EAST, A
DISTANCE OF 150.00 FEET;
THENCE SOUTH, A DIS-
TANCE OF 201.93 FEET TO
THE POINT OF BEGINNING.
TOGETHER WITH TWIN
DOUBLEWIDE MOBILE
HOME VIN FLA14611917A
AND FLA14611917B.

ANY PERSON CLAIMING AN IN-
TEREST IN THE SURPLUS FROM
THE SALE, IF ANY, OTHER THAN
THE PROPERTY OWNER AS OF
THE DATE OF THE LIS PENDENS
MUST FILE A CLAIM WITHIN 60
DAYS AFTER THE SALE.

If you are a person with a disability
who needs any accommodation in order
to participate in this proceeding, you
are entitled, at no cost to you, to the
provision of certain assistance. Please
contact the Public Information Dept.,
Pasco County Government Center, 7530
Little Rd., New Port Richey, FL 34654;
(727) 847-8110 (V) in New Port Richey;
(352) 521-4274, ext 8110 (V) in Dade
City, at least 7 days before your sched-
uled court appearance, or immediately
upon receiving this notification if the
time before the scheduled appearance is
less than 7 days; if you are hearing im-
paired call 711. The court does not pro-
vide transportation and cannot accom-
modate for this service. Persons with
disabilities needing transportation to
court should contact their local public
transportation providers for informa-
tion regarding transportation services.

Dated this 11 day of July, 2016.
By: Melanie Golden, Esq.
Bar Number: 11900

Submitted by:
Choice Legal Group, P.A.
P.O. Box 9908
Fort Lauderdale, FL 33310-0908
Telephone: (954) 453-0365
Facsimile: (954) 771-6052
Toll Free: 1-800-441-2438
DESIGNATED PRIMARY E-MAIL
FOR SERVICE PURSUANT TO FLA.
R. JUD. ADMIN 2.516
eservice@legalgroup.com
11-26715
July 15, 22, 2016 16-02018P

SECOND INSERTION

NOTICE OF SALE
IN THE CIRCUIT COURT OF THE
SIXTH JUDICIAL CIRCUIT, IN AND
FOR PASCO COUNTY, FLORIDA

CASE NO.:
51-2014-CA-003254CAAXWS
BANK OF AMERICA, N.A.;
Plaintiff, vs.
FERNANDO JUAN; DEANA JUAN;
ET AL.

Defendants.
NOTICE IS GIVEN that, in accordance
with the Order to Reschedule
Foreclosure Sale dated June 7, 2016
in the above-styled cause, I will sell to
the highest and best bidder for cash at
www.pasco.realforeclose.com, on July
28, 2016 at 11:00 a.m. the following de-
scribed property:

LOT 117, AUTUMN OAKS,
UNIT TWO, ACCORDING TO
THE PLAT THEREOF AS RE-
CORDED IN PLAT BOOK 27,
PAGE(S) 33 THROUGH 35, OF
THE PUBLIC RECORDS OF
PASCO COUNTY, FLORIDA.
PROPERTY ADDRESS: 14133
DEER TRAIL DRIVE, HUD-
SON, FL 34667, Pasco
ANY PERSON CLAIMING AN IN-
TEREST IN THE SURPLUS FROM
THE SALE, IF ANY, OTHER THAN
THE PROPERTY OWNER AS OF
THE DATE OF THE LIS PENDENS
MUST FILE A CLAIM WITHIN 60
DAYS AFTER THE SALE.

If you are a person with a disability
who needs any accommodation in order
to participate in this proceeding,
you are entitled, at no cost to you,
to the provision of certain assistance.
Please contact the Public Information
Dept., Pasco County Government
Center, 7530 Little Rd., New Port Richey,
FL 34654; (727) 847-8110 (V) in New
Port Richey; (352) 521-4274, ext 8110
(V) in Dade City, at least 7 days before
your scheduled court appearance, or
immediately upon receiving this notifi-
cation if the time before the scheduled
appearance is less than 7 days; if you
are hearing impaired call 711. The court
does not provide transportation and
cannot accommodate for this service.
Persons with disabilities needing trans-
portation to court should contact their
local public transportation providers
for information regarding transporta-
tion services.

DATED this 6 day of July, 2016
Keith Lehman, Esq.
FBN. 85111
Attorneys for Plaintiff
Marinosci Law Group, P.C.
100 West Cypress Creek Road,
Suite 1045
Fort Lauderdale, FL 33309
Phone: (954)-644-8704;
Fax (954) 772-9601
ServiceFL@mlg-defaultlaw.com
ServiceFL2@mlg-defaultlaw.com
July 15, 22, 2016 16-01998P

SECOND INSERTION

NOTICE TO CREDITORS
IN THE CIRCUIT COURT FOR
PASCO COUNTY, FLORIDA
PROBATE DIVISION
File No.
51-2016-CP-000731-WS
Division J
IN RE: ESTATE OF
JULIAN S. SLAVINSKY
Deceased.

The administration of the estate of
JULIAN S. SLAVINSKY, deceased,
whose date of death was May 28,
2016, is pending in the Circuit
Court for PASCO County, Florida,
Probate Division, the address of
which is P.O. Drawer 338, New Port
Richey, Florida 34656-0338. The
names and addresses of the personal
representative and the personal
representative's attorney are set
forth below.

All creditors of the decedent and
other persons having claims or de-
mands against decedent's estate on
whom a copy of this notice is required
to be served must file their claims
with this court ON OR BEFORE
THE LATER OF 3 MONTHS AFTER
THE TIME OF THE FIRST PUBLI-
CATION OF THIS NOTICE OR 30
DAYS AFTER THE DATE OF SER-
VICE OF A COPY OF THIS NOTICE
ON THEM.

All other creditors of the decedent
and other persons having claims or de-
mands against decedent's estate must
file their claims with this court WITH-
IN 3 MONTHS AFTER THE DATE OF
THE FIRST PUBLICATION OF THIS
NOTICE.

ALL CLAIMS NOT FILED WITHIN
THE TIME PERIODS SET FORTH
IN FLORIDA STATUTES SEC-
TION 733.702 WILL BE FOREVER
BARRED.

NOTWITHSTANDING THE TIME
PERIODS SET FORTH ABOVE, ANY
CLAIM FILED TWO (2) YEARS OR
MORE AFTER THE DECEDENT'S
DATE OF DEATH IS BARRED.

The date of first publication of this
notice is July 15, 2016.

Personal Representative:
DANIEL PAUL SLAVINSKY
10015 Trinity Blvd., Suite 101
Trinity, FL 34655
Attorney for Personal Representative:
DAVID J. WOLLINKA
Attorney
Florida Bar Number: 608483
WOLLINKA, WOLLINKA &
DODDRIDGE
10015 TRINITY BLVD
SUITE 101
TRINITY, FL 34655
Telephone: (727) 937-4177
Fax: (727) 478-7007
E-Mail: pleadings@wollinka.com
Secondary E-Mail:
jamie@wollinka.com
July 15, 22, 2016 16-02044P

Hillsborough & Pasco Counties

P: (813) 221-9505 F: (813) 221-9403

SECOND INSERTION

NOTICE OF SALE
Pursuant to Chapter 45 IN THE CIRCUIT COURT OF THE 6TH JUDICIAL CIRCUIT IN AND FOR PASCO COUNTY, FLORIDA GENERAL JURISDICTION DIVISION
CASE NO: 2016CA000309CAAXES
Concord Station Community Association, Inc., a Florida Non Profit Corporation, Plaintiff, v. Romeo Belunta and Kelly M. Belunta, Defendant(s).
NOTICE OF SALE IS HEREBY GIVEN pursuant to an Order of Final Judgment of Foreclosure dated June 29, 2016 and entered in Case No. 2016CA-000309CAAXES of the Circuit Court of the Sixth Judicial Circuit in and for Pasco County, Florida wherein Concord Station Community Association, Inc., is Plaintiff, and Romeo Belunta and Kelly M. Belunta, the Defendant, the Clerk of Court will sell to the highest and best bidder for cash on www.pasco.realforeclose.com at 11:00 o'clock A.M. on the 11th day of August, 2016, the following described property as set forth in said Order of Final Judgment to wit:
LOT 11, BLOCK B, CONCORD STATION PHASES 4 UNITS A AND B, ACCORDING TO THE PLAT THEREOF, AS RECORDED IN PLAT BOOK 60, PAGE 110, PUBLIC RECORDS OF PASCO COUNTY, FLORIDA.
Property Address: 3233 Trinity Cottage Drive, Land O Lakes, FL 34638.

Any person claiming an interest in the surplus from the sale, if any, other than the property owner as of the date of the Lis Pendens must file a claim within sixty (60) Days after the sale.
AMERICANS WITH DISABILITIES ACT ASSISTANCE If you are a person with a disability who needs any accommodation in order to participate in this proceeding, you are entitled, at no cost to you, to the provision of certain assistance. Please contact the Public Information Dept., Pasco County Government Center, 7530 Little Rd., New Port Richey, FL 34654; (727) 847-8110 (V) in New Port Richey; (352) 521-4274, ext 8110 (V) in Dade City, at least 7 days before your scheduled court appearance, or immediately upon receiving this notification if the time before the scheduled appearance is less than 7 days; if you are hearing impaired call 711. The court does not provide transportation and cannot accommodate for this service. Persons with disabilities needing transportation to court should contact their local public transportation providers for information regarding transportation services.
Dated this 7 day of July, 2016.
ASSOCIATION LAW GROUP, P.L.L.C.
Attorney for the Plaintiff
By: David W. Krempa, Esq., Florida Bar No. 59139
Primary Email: dkrempa@algp.com
Secondary Email: filings@algp.com
Association Law Group, P.L.L.C.
Post Office Box 311059
Miami, Florida 33231
Phone: (305) 938-6922
Fax: (305) 938-6914
July 15, 22, 2016 16-02042P

SECOND INSERTION

NOTICE OF ACTION
IN THE CIRCUIT COURT OF THE SIXTH JUDICIAL CIRCUIT IN AND FOR PASCO COUNTY, FLORIDA
CASE NO.:
51-2012-CA-003187-CAAX-WS
GREEN TREE SERVICING LLC, Plaintiff, VS. HOA PROBLEM SOLUTIONS, INC., AS TRUSTEE OF THE 11904 YELLOW FINCH LANE; et al., Defendant(s).
TO: UNKNOWN HEIRS BENEFICIARIES, DEVISEES, SURVIVING SPOUSE, GRANTEEES, ASSIGNEE, LIENORS, CREDITORS, TRUSTEES, AND ALL OTHER PARTIES CLAIMING AN INTEREST BY THROUGH UNDER OR AGAINST THE ESTATE OF SUSAN SAVILLE, DECEASED.
Last Known Residence: UNKNOWN
YOU ARE HEREBY NOTIFIED that an action to foreclose a mortgage on the following property in Pasco County, Florida:
LOT 56, HERITAGE SPRINGS VILLAGE 14 UNIT 2, ACCORDING TO THE PLAT THEREOF, AS RECORDED IN PLAT BOOK 44, PAGES 142-147, OF THE PUBLIC RECORDS OF PASCO COUNTY, FLORIDA.
has been filed against you and you are required to serve a copy of your written defenses, if any, to it on ALDRIDGE | PITE, LLP, Plaintiff's attorney, at 1615 South Congress Avenue, Suite 200, Delray Beach, FL 33445 (Phone Number: (561) 392-6391), within 30 days of the first date of publication of this notice, and file the original with the

clerk of this court either before 8/15/16 on Plaintiff's attorney or immediately thereafter; otherwise a default will be entered against you for the relief demanded in the complaint or petition.
If you are a person with a disability who needs any accommodation in order to participate in this proceeding, you are entitled, at no cost to you, to the provision of certain assistance. Please contact the Public Information Dept., Pasco County Government Center, 7530 Little Rd., New Port Richey, FL 34654; (727) 847-8110 (V) in New Port Richey; (352) 521-4274, ext 8110 (V) in Dade City, at least 7 days before your scheduled court appearance, or immediately upon receiving this notification if the time before the scheduled appearance is less than 7 days; if you are hearing impaired call 711. The court does not provide transportation and cannot accommodate for this service. Persons with disabilities needing transportation to court should contact their local public transportation providers for information regarding transportation services.
Dated on July 7, 2016.
Paula S. O'Neil, Ph.D., Clerk & Comptroller
By: Carmella Hernandez As Deputy Clerk
ALDRIDGE | PITE, LLP
Plaintiff's attorney
1615 South Congress Avenue, Suite 200
Delray Beach, FL 33445
(Phone Number: (561) 392-6391)
1382-1194B
July 15, 22, 2016 16-02007P

SECOND INSERTION

NOTICE OF FORECLOSURE SALE
IN THE CIRCUIT COURT OF THE SIXTH JUDICIAL CIRCUIT IN AND FOR PASCO COUNTY, FLORIDA
GENERAL JURISDICTION DIVISION
Case No.
51-2010-CA-007646-CAAX-ES
Freedom Mortgage Corporation, Plaintiff, vs. Scott Blitch; Barbara Blitch; Country Walk Homeowners' Association Inc.; Unknown Tenant #1; Unknown Tenant #2, Defendants.
NOTICE IS HEREBY GIVEN pursuant to a Final Judgment of Foreclosure dated June 13, 2016 entered in Case No. 51-2010-CA-007646-CAAX-ES of the Circuit Court of the Sixth Judicial Circuit, in and for Pasco County, Florida, wherein Freedom Mortgage Corporation is the Plaintiff and Scott Blitch; Barbara Blitch; Country Walk Homeowners' Association Inc.; Unknown Tenant #1; Unknown Tenant #2 are the Defendants, that Paula O'Neil, Pasco County Clerk of Court will sell to the highest and best bidder for cash by electronic sale at www.pasco.realforeclose.com, beginning at 11:00 AM on the 28th day of July, 2016, the following described property as set forth in said Final Judgment, to wit:
LOT 114 OF COUNTRY WALK INCREMENT D-PHASE 1, ACCORDING TO THE PLAT THEREOF AS RECORDED IN PLAT BOOK 55, PAGE(S) 36-41, OF THE PUBLIC RE-

CORDS OF PASCO COUNTY, FLORIDA.
Any person claiming an interest in the surplus from the sale, if any, other than the property owner as of the date of the lis pendens must file a claim within 60 days after the sale.
If you are a person with a disability who needs any accommodation in order to participate in this proceeding, you are entitled, at no cost to you, to the provision of certain assistance. Please contact the Public Information Dept., Pasco County Government Center, 7530 Little Rd., New Port Richey, FL 34654; (727) 847-8110 (V) in New Port Richey; (352) 521-4274, ext 8110 (V) in Dade City, at least 7 days before your scheduled court appearance, or immediately upon receiving this notification if the time before the scheduled appearance is less than 7 days; if you are hearing impaired call 711. The court does not provide transportation and cannot accommodate for this service. Persons with disabilities needing transportation to court should contact their local public transportation providers for information regarding transportation services.
Dated this 11 day of July, 2016.
By Kathleen McCarthy, Esq. Florida Bar No. 72161
BROCK & SCOTT, PLLC
Attorney for Plaintiff
1501 N.W. 49th Street, Suite 200
Ft. Lauderdale, FL 33309
Phone: (954) 618-6955, ext. 6177
Fax: (954) 618-6954
FL.CourtDocs@brockandscott.com
File # 13-F06613
July 15, 22, 2016 16-02020P

SECOND INSERTION

NOTICE OF SALE
PURSUANT TO CHAPTER 45 IN THE CIRCUIT COURT OF THE SIXTH JUDICIAL CIRCUIT IN AND FOR PASCO COUNTY, FLORIDA CIVIL ACTION
CASE NO.: 51-2013-CA-003511-WS
FEDERAL NATIONAL MORTGAGE ASSOCIATION, Plaintiff, vs. DINOVO, PETER J. et al, Defendant(s).
NOTICE IS HEREBY GIVEN Pursuant to a Final Judgment of Foreclosure dated 9 June, 2016, and entered in Case No. 51-2013-CA-003511-WS of the Circuit Court of the Sixth Judicial Circuit in and for Pasco County, Florida in which Federal National Mortgage Association, is the Plaintiff and Bank of America, N.A., Peter J. Dinovo, Tindara S. Dinovo, Trinity Communities Master Association, Inc., Trinity West Community Association, Inc., are defendants, the Pasco County Clerk of the Circuit Court will sell to the highest and best bidder for cash in/on held online www.pasco.realforeclose.com in Pasco County, Florida, Pasco County, Florida at 11:00 AM on the 10th of August, 2016, the following described property as set forth in said Final Judgment of Foreclosure:
LOT 85, TRINITY WEST PHASE 2, ACCORDING TO THE MAP OR PLAT THEREOF RECORDED IN PLAT BOOK 53, PAGES 115 TO 119, INCLUSIVE, OF THE PUBLIC RECORDS OF PASCO COUNTY, FLORIDA.
2730 MICAH DR TRINITY FL 34655-5175
Any person claiming an interest in the

surplus from the sale, if any, other than the property owner as of the date of the Lis Pendens must file a claim within 60 days after the sale.
If you are a person with a disability who needs an accommodation in order to participate in this proceeding, you are entitled, at no cost to you, to the provision of certain assistance. Please contact:
Public Information Dept., Pasco County Government Center, 7530 Little Rd., New Port Richey, FL 34654
Phone: 727.847.8110 (voice) in New Port Richey or 352.521.4274, ext 8110 (voice) in Dade City or 711 for the hearing impaired.
Contact should be initiated at least seven days before the scheduled court appearance, or immediately upon receiving this notification if the time before the scheduled appearance is less than seven days.
The court does not provide transportation and cannot accommodate such requests. Persons with disabilities needing transportation to court should contact their local public transportation providers for information regarding transportation services.
Dated in Hillsborough County, Florida this 11th day of July, 2016.
Grant Dostie, Esq.
FL Bar # 119886
Albertelli Law
Attorney for Plaintiff
P.O. Box 23028
Tampa, FL 33623
(813) 221-4743
(813) 221-9171 facsimile
eService: servealaw@albertellilaw.com
JR- 012034F01
July 15, 22, 2016 16-02021P

SECOND INSERTION

NOTICE OF FORECLOSURE SALE
IN THE CIRCUIT COURT OF THE 6TH JUDICIAL CIRCUIT, IN AND FOR PASCO COUNTY, FLORIDA
CIVIL DIVISION:
CASE NO.:
51-2013-CA-000415 WS
JPMORGAN CHASE BANK, NATIONAL ASSOCIATION, Plaintiff, vs. HOWARD HERBST; UNKNOWN TENANT IN POSSESSION OF THE SUBJECT PROPERTY, Defendants.
NOTICE IS HEREBY GIVEN pursuant to Final Judgment of Foreclosure dated the 9th day of June 2016 and entered in Case No. 51-2013-CA-000415 WS, of the Circuit Court of the 6TH Judicial Circuit in and for Pasco County, Florida, wherein FEDERAL NATIONAL MORTGAGE ASSOCIATION is the Plaintiff and HOWARD HERBST; and UNKNOWN TENANT(S) IN POSSESSION OF THE SUBJECT PROPERTY are defendants. The Clerk of this Court shall sell to the highest and best bidder for cash, on the 1st day of August 2016 at 11:00 AM on Pasco County's Public Auction website: www.pasco.realforeclose.com, pursuant to judgment or order of the Court, in accordance with Chapter 45, Florida Statutes, the following described property as set forth in said Final Judgment, to wit:
LOT 49, KNOLLWOOD VILLAGE, ACCORDING TO THE PLAT THEREOF AS RECORDED IN PLAT BOOK 7, PAGE(S) 90, OF THE PUBLIC RECORDS OF PASCO COUNTY, FLORIDA.
ANY PERSON CLAIMING AN INTEREST IN THE SURPLUS FROM

THE SALE, IF ANY, OTHER THAN THE PROPERTY OWNER AS OF THE DATE OF THE LIS PENDENS MUST FILE A CLAIM WITHIN 60 DAYS AFTER THE SALE.
If you are a person with a disability who needs any accommodation in order to participate in this proceeding, you are entitled, at no cost to you, to the provision of certain assistance. Please contact the Public Information Dept., Pasco County Government Center, 7530 Little Rd., New Port Richey, FL 34654; (727) 847-8110 (V) in New Port Richey; (352) 521-4274, ext 8110 (V) in Dade City, at least 7 days before your scheduled court appearance, or immediately upon receiving this notification if the time before the scheduled appearance is less than 7 days; if you are hearing impaired call 711. The court does not provide transportation and cannot accommodate for this service. Persons with disabilities needing transportation to court should contact their local public transportation providers for information regarding transportation services.
Dated this 11 day of July, 2016.
By: Melanie Golden, Esq.
Bar Number: 11900
Submitted by:
Choice Legal Group, P.A.
P.O. Box 9908
Fort Lauderdale, FL 33310-0908
Telephone: (954) 453-0365
Facsimile: (954) 771-6052
Toll Free: 1-800-441-2438
DESIGNATED PRIMARY E-MAIL FOR SERVICE PURSUANT TO FLA. R. JUD. ADMIN 2.516
eService@clegalgroup.com
10-40781
July 15, 22, 2016 16-02017P

SECOND INSERTION

NOTICE OF ACTION
IN THE CIRCUIT COURT OF THE SIXTH JUDICIAL CIRCUIT IN AND FOR PASCO COUNTY, FLORIDA
CASE NO.:
2016CA000943CAAXES/J4
WELLS FARGO BANK N.A., Plaintiff, VS. UNKNOWN HEIRS, BENEFICIARIES, DEVISEES, SURVIVING SPOUSE, GRANTEEES, ASSIGNEE, LIENORS, CREDITORS, TRUSTEES, AND ALL OTHER PARTIES CLAIMING AN INTEREST BY THROUGH UNDER OR AGAINST THE ESTATE OF MARIA JAIME, DECEASED; et al., Defendant(s).
TO: Sara Joseph
Teresa Jaime
Last Known Residence: 29842 Morningmist Drive, Wesley Chapel, FL 33543
YOU ARE HEREBY NOTIFIED that an action to foreclose a mortgage on the following property in Pasco County, Florida:
LOT(S) 84, BLOCK 1 OF MEADOW POINTE PARCEL 9, UNIT 2 AS RECORDED IN PLAT BOOK 34, PAGE 132-136, ET SEQ., OF THE PUBLIC RECORDS OF PASCO COUNTY, FLORIDA
has been filed against you and you are required to serve a copy of your written defenses, if any, to it on ALDRIDGE | PITE, LLP, Plaintiff's attorney, at 1615 South Congress Avenue, Suite 200, Delray Beach, FL 33445 (Phone Number: (561) 392-6391), within 30 days of the first date of publication of this notice,

and file the original with the clerk of this court either before AUG 15 2016 on Plaintiff's attorney or immediately thereafter; otherwise a default will be entered against you for the relief demanded in the complaint or petition.
If you are a person with a disability who needs any accommodation in order to participate in this proceeding, you are entitled, at no cost to you, to the provision of certain assistance. Please contact the Public Information Dept., Pasco County Government Center, 7530 Little Rd., New Port Richey, FL 34654; (727) 847-8110 (V) in New Port Richey; (352) 521-4274, ext 8110 (V) in Dade City, at least 7 days before your scheduled court appearance, or immediately upon receiving this notification if the time before the scheduled appearance is less than 7 days; if you are hearing impaired call 711. The court does not provide transportation and cannot accommodate for this service. Persons with disabilities needing transportation to court should contact their local public transportation providers for information regarding transportation services.
Dated on July 11, 2016.
Paula S. O'Neil, Ph.D., Clerk & Comptroller
As Clerk of the Court
By: Geraldo Salgado As Deputy Clerk
ALDRIDGE | PITE, LLP
Plaintiff's attorney
1615 South Congress Avenue, Suite 200
Delray Beach, FL 33445
(Phone Number: (561) 392-6391)
1113-752318B
July 15, 22, 2016 16-02028P

SECOND INSERTION

NOTICE OF FORECLOSURE SALE
PURSUANT TO CHAPTER 45 IN THE CIRCUIT COURT OF THE SIXTH JUDICIAL CIRCUIT IN AND FOR PASCO COUNTY, FLORIDA
CASE NO.:
2014CA003807CAAXES
GREEN TREE SERVICING LLC, Plaintiff, VS. BRENDA F. JOHNSON; et al., Defendant(s).
NOTICE IS HEREBY GIVEN that sale will be made pursuant to an Order or Final Judgment. Final Judgment was awarded on June 1, 2016 in Civil Case No. 2014CA003807CAAXES, of the Circuit Court of the SIXTH Judicial Circuit in and for Pasco County, Florida, wherein, GREEN TREE SERVICING LLC is the Plaintiff, and BRENDA F. JOHNSON; JAMES R. JOHNSON; PLANTATION PALMS HOMEOWNERS ASSOCIATION, INC.; CI BANK F/K/A COMMUNITY BANK & COMPANY F/K/A COMMUNITY BANK OF MANATEE; UNKNOWN TENANT 1 N/K/A STACI JOHNSON; ANY AND ALL UNKNOWN PARTIES CLAIMING BY THROUGH, UNDER AND AGAINST THE HEREIN NAMED INDIVIDUAL DEFENDANT(S) WHO ARE NOT KNOWN TO BE DEAD OR ALIVE, WHETHER SAID UNKNOWN PARTIES MAY CLAIM AN INTEREST AS SPOUSES, HEIRS, DEVISEES, GRANTEEES, OR OTHER CLAIMANTS are Defendants.
The clerk of the court, Paula O'Neil will sell to the highest bidder for cash at www.pasco.realforeclose.com on August 1, 2016 at 11:00 AM, the following described real property as set forth in said Final Judgment, to wit:
LOT 757, OF PLANTATION PALMS, PHASE SIX, ACCORDING TO THE PLAT THEREOF, AS RECORDED IN PLAT BOOK 48, PAGE(S) 78-81, OF THE PUBLIC RECORDS OF

PASCO COUNTY, FLORIDA.
ANY PERSON CLAIMING AN INTEREST IN THE SURPLUS FROM THE SALE, IF ANY, OTHER THAN THE PROPERTY OWNER AS OF THE DATE OF THE LIS PENDENS MUST FILE A CLAIM WITHIN 60 DAYS AFTER THE SALE.
IMPORTANT
AMERICANS WITH DISABILITIES ACT: If you are a person with a disability who needs an accommodation in order to participate in this proceeding, you are entitled, at no cost to you, to the provision of certain assistance. Please contact: Public Information Dept., Pasco County Government Center, 7530 Little Rd., New Port Richey, FL 34654; Phone: 727.847.8110 (voice) in New Port Richey, 352.521.4274, ext 8110 (voice) in Dade City, Or 711 for the hearing impaired. Contact should be initiated at least seven days before the scheduled court appearance, or immediately upon receiving this notification if the time before the scheduled appearance is less than seven days. The court does not provide transportation and cannot accommodate such requests. Persons with disabilities needing transportation to court should contact their local public transportation providers for information regarding transportation services.
Dated this 7 day of July, 2016.
By: Susan Sparks
FBN: 33626
for Susan W. Findley, Esq.
FBN: 160600
Primary E-Mail:
ServiceMail@aldridgepite.com
ALDRIDGE | PITE, LLP
Attorney for Plaintiff
1615 South Congress Avenue
Suite 200
Delray Beach, FL 33445
Telephone: (844) 470-8804
Facsimile: (561) 392-6965
1382-616B
July 15, 22, 2016 16-02002P

SECOND INSERTION

NOTICE OF ACTION
IN THE CIRCUIT COURT OF THE 6TH JUDICIAL CIRCUIT, IN AND FOR PASCO COUNTY, FLORIDA.
CASE NO.:
2015-CA-002564-CAAXWS
WELLS FARGO BANK, NATIONAL ASSOCIATION, AS TRUSTEE FOR MASTR ASSET BACKED SECURITIES TRUST 2003-OPT2, MORTGAGE PASS-THROUGH CERTIFICATES, SERIES 2003-OPT2, Plaintiff, vs. The unknown spouse, heirs, beneficiaries, devisees, grantees, assignees, lienors, creditors, trustees and all other parties claiming an interest by, through, under or against the Estate of Edward J. Sottile a/k/a Edward J. Sottile, Sr., now deceased; Unknown Tenant #1; Unknown Tenant #2, Defendants.
TO: Edward J. Sottile
Residence Unknown
Margaret Mary Sottile
Residence Unknown
Virginia M. Sottile possibly known as Virginia Lockhart
Residence Unknown
If living: if dead, all unknown parties claiming interest by, through, under or against the above named defendant(s), whether said unknown parties claim as heirs, devisees, grantees, creditors, or other claimants; and all parties having or claiming to have any right, title or interest in the property herein described.
YOU ARE NOTIFIED that an action to foreclose a mortgage on the following described property in Pasco County, Florida:
Lot 20, Holiday Lakes West Unit One, according to the map or plat thereof, as Recorded in Plat Book 23, Pages 17, 18 and 19, inclusive, of the Public Records of Pasco County, Florida.
Street Address: 1203 Mandarin

Drive, Holiday, FL 34691
*on or before 8/15/16
has been filed against you and you are required to serve a copy of your written defenses, if any, to it on Clarfield, Okon, Salomone & Pincus, P.L.L., Plaintiff's attorney, whose address is 500 Australian Avenue South, Suite 825, West Palm Beach, FL 33401, within 30 days after the date of the first publication of this notice and file the original with the Clerk of this Court, otherwise, a default will be entered against you for the relief demanded in the complaint or petition.
If you are a person with a disability who needs any accommodation in order to participate in this proceeding, you are entitled, at no cost to you, to the provision of certain assistance. Please contact the Public Information Dept., Pasco County Government Center, 7530 Little Rd., New Port Richey, FL 34654; (727) 847-8110 (V) in New Port Richey; (352) 521-4274, ext 8110 (V) in Dade City, at least 7 days before your scheduled court appearance, or immediately upon receiving this notification if the time before the scheduled appearance is less than 7 days; if you are hearing impaired call 711. The court does not provide transportation and cannot accommodate for this service. Persons with disabilities needing transportation to court should contact their local public transportation providers for information regarding transportation services.
DATED on July 5, 2016.
Paula S. O'Neil, Ph.D., Clerk & Comptroller
By: Carmella Hernandez As Deputy Clerk
Clarfield, Okon, Salomone & Pincus, P.L.L., Attorney for Plaintiff
500 Australian Avenue South, Suite 825
West Palm Beach, FL 33401
Telephone: (561) 713-1400-pleadings@cosplaw.com
July 15, 22, 2016 16-01988P

SECOND INSERTION

NOTICE OF FORECLOSURE SALE
IN THE CIRCUIT COURT OF THE 6TH JUDICIAL CIRCUIT, IN AND FOR PASCO COUNTY, FLORIDA
CIVIL DIVISION:
CASE NO.:
51-2014-CA-002984-WS - FEDERAL NATIONAL MORTGAGE ASSOCIATION ("FNMA"), A CORPORATION ORGANIZED AND EXISTING UNDER THE LAWS OF THE UNITED STATES OF AMERICA Plaintiff, vs. RAYMOND D. CLARK; SOLYMAR R. CLARK UNKNOWN TENANT I; UNKNOWN TENANT II; BANK OF AMERICA, N.A., and any unknown heirs, devisees, grantees, creditors, and other unknown persons or unknown spouses claiming by, through and under any of the above-named defendants, Defendants.
NOTICE IS HEREBY GIVEN pursuant to Final Judgment of Foreclosure dated the 9th day of June 2016 and entered in Case No. 51-2014-CA-002984-WS -, of the Circuit Court of the 6TH Judicial Circuit in and for Pasco County, Florida, wherein FEDERAL NATIONAL MORTGAGE ASSOCIATION ("FNMA") is the Plaintiff and RAYMOND D. CLARK; SOLYMAR R. CLARK; BANK OF AMERICA, N.A.; and UNKNOWN TENANT(S) IN POSSESSION OF THE SUBJECT PROPERTY are defendants. The Clerk of this Court shall sell to the highest and best bidder for cash, on the 3rd day of August 2016 at 11:00 AM on Pasco County's Public Auction website: www.pasco.realforeclose.com, pursuant to judgment or order of the Court, in accordance with Chapter 45, Florida Statutes, the following described property as set forth in said Final Judgment, to wit:
LOT 75 AND THE WEST 15 FEET OF LOT 76, VIVA VIL-

LAS, ACCORDING TO THE PLAT THEREOF AS RECORDED IN PLAT BOOK 13, PAGE 3 OF THE PUBLIC RECORDS OF PASCO COUNTY, FLORIDA
ANY PERSON CLAIMING AN INTEREST IN THE SURPLUS FROM THE SALE, IF ANY, OTHER THAN THE PROPERTY OWNER AS OF THE DATE OF THE LIS PENDENS MUST FILE A CLAIM WITHIN 60 DAYS AFTER THE SALE.
If you are a person with a disability who needs any accommodation in order to participate in this proceeding, you are entitled, at no cost to you, to the provision of certain assistance. Please contact the Public Information Dept., Pasco County Government Center, 7530 Little Rd., New Port Richey, FL 34654; (727) 847-8110 (V) in New Port Richey; (352) 521-4274, ext 8110 (V) in Dade City, at least 7 days before your scheduled court appearance, or immediately upon receiving this notification if the time before the scheduled appearance is less than 7 days; if you are hearing impaired call 711. The court does not provide transportation and cannot accommodate for this service. Persons with disabilities needing transportation to court should contact their local public transportation providers for information regarding transportation services.
Dated this 11 day of July, 2016.
By: Melanie Golden, Esq.
Bar Number: 11900
Submitted by:
Choice Legal Group, P.A.
P.O. Box 9908
Fort Lauderdale, FL 33310-0908
Telephone: (954) 453-0365
Facsimile: (954) 771-6052
Toll Free: 1-800-441-2438
DESIGNATED PRIMARY E-MAIL FOR SERVICE PURSUANT TO FLA. R. JUD. ADMIN 2.516
eService@clegalgroup.com
15-01014
July 15, 22, 2016 16-02016P

SECOND INSERTION

NOTICE OF ACTION - CONSTRUCTIVE SERVICE IN THE CIRCUIT COURT OF THE SIXTH JUDICIAL CIRCUIT IN AND FOR PASCO COUNTY, FLORIDA GENERAL JURISDICTION DIVISION

Case No. 2016CA001172CAAXWS
Wells Fargo Bank, N.A.
Plaintiff, vs.
John G. Ward, et al,
Defendants.

TO: Seven Springs Civic Association, Inc.
Last Known Address: c/o Duncan Registered Agent, 7643 Atherton Avenue, New Port Richey, FL 34655

YOU ARE HEREBY NOTIFIED that an action to foreclose a mortgage on the following property in Pasco County, Florida: LOT 1538, SEVEN SPRINGS HOMES, UNIT SIX, ACCORDING TO THE MAP OR PLAT THEREOF AS RECORDED IN PLAT BOOK 19, PAGES 14 THROUGH 16, PUBLIC RECORDS OF PASCO COUNTY RECORDS.

has been filed against you and you are required to serve a copy of your written defenses, if any, to it on Katherine E. Tilka, Esquire, Brock & Scott, PLLC, the Plaintiff's attorney, whose address is 1501 N.W. 49th Street, Suite 200, Ft. Lauderdale, FL 33309, within thirty (30) days of the first date of publication on or before 8/15/16, and file the original with the Clerk of this Court either before service on the Plaintiff's attorney or immediately thereafter; otherwise a

default will be entered against you for the relief demanded in the complaint or petition.

THIS NOTICE SHALL BE PUBLISHED ONCE A WEEK FOR TWO (2) CONSECUTIVE WEEKS

If you are a person with a disability who needs any accommodation in order to participate in this proceeding, you are entitled, at no cost to you, to the provision of certain assistance. Please contact the Public Information Dept., Pasco County Government Center, 7530 Little Rd., New Port Richey, FL 34654; (727) 847-8110 (V) in New Port Richey; (352) 521-4274, ext 8110 (V) in Dade City, at least 7 days before your scheduled court appearance, or immediately upon receiving this notification if the time before the scheduled appearance is less than 7 days; if you are hearing impaired call 711. The court does not provide transportation and cannot accommodate for this service. Persons with disabilities needing transportation to court should contact their local public transportation providers for information regarding transportation services.

DATED on July 7, 2016.
Paula S. O'Neil, Ph.D.,
Clerk & Comptroller
By Carmella Hernandez
As Deputy Clerk
Katherine E. Tilka, Esquire
Brock & Scott, PLLC,
the Plaintiff's attorney,
1501 N.W. 49th Street, Suite 200
Ft. Lauderdale, FL 33309
File # 15-F11368
July 15, 22, 2016 16-02004P

SECOND INSERTION

NOTICE OF RESCHEDULED FORECLOSURE SALE IN THE CIRCUIT COURT OF THE SIXTH JUDICIAL CIRCUIT IN AND FOR PASCO COUNTY, FLORIDA GENERAL JURISDICTION DIVISION

Case No. 51-2013-CA-005192ES
Wells Fargo Bank, N.A.,
Plaintiff, vs.
William N Rivera, et al,
Defendants.

NOTICE IS HEREBY GIVEN pursuant to an Order Granting Motion to Reset Foreclosure Sale, dated June 7, 2016, in Case No. 51-2013-CA-005192ES of the Circuit Court of the Sixth Judicial Circuit, in and for Pasco County, Florida, wherein Wells Fargo Bank, N.A. is the Plaintiff and William N Rivera; Michelle J Rivera; Citibank, National Association; Meadow Pointe Iii Homeowner's Association, Inc.; Unknown Tenant(s) In Possession are the Defendants, that Paula O'Neil, Pasco County Clerk of Court will sell to the highest and best bidder for cash by electronic sale at www.pasco.realforeclose.com, beginning at 11:00 AM on the 9th day of August, 2016, the following described property as set forth in said Final Judgment, to wit:

LOT 108, BLOCK 2, MEADOW POINTE III, PHASE 1, UNIT 2B, ACCORDING TO THE PLAT THEREOF AS RECORDED IN PLAT BOOK 44, PAGES 97 THROUGH 104, OF THE

PUBLIC RECORDS OF PASCO COUNTY, FLORIDA.

Any person claiming an interest in the surplus from the sale, if any, other than the property owner as of the date of the lis pendens must file a claim within 60 days after the sale.

If you are a person with a disability who needs any accommodation in order to participate in this proceeding, you are entitled, at no cost to you, to the provision of certain assistance. Please contact the Public Information Dept., Pasco County Government Center, 7530 Little Rd., New Port Richey, FL 34654; (727) 847-8110 (V) in New Port Richey; (352) 521-4274, ext 8110 (V) in Dade City, at least 7 days before your scheduled court appearance, or immediately upon receiving this notification if the time before the scheduled appearance is less than 7 days; if you are hearing impaired call 711. The court does not provide transportation and cannot accommodate for this service. Persons with disabilities needing transportation to court should contact their local public transportation providers for information regarding transportation services.

By Jimmy Edwards, Esq.
Florida Bar No. 81855
BROCK & SCOTT, PLLC
Attorney for Plaintiff
1501 N.W. 49th Street, Suite 200
Ft. Lauderdale, FL 33309
Phone: (954) 618-6955, ext. 6209
Fax: (954) 618-6954
FLCourtDocs@brockandscott.com
File # 15-F10005
July 15, 22, 2016 16-02032P

SECOND INSERTION

NOTICE OF ACTION FORECLOSURE PROCEEDINGS-PROPERTY IN THE CIRCUIT COURT OF THE SIXTH JUDICIAL CIRCUIT IN AND FOR PASCO COUNTY, FLORIDA CIVIL DIVISION

Case #: 51-2016-CA-001254
DIVISION: J3

PNC Bank, National Association
Plaintiff, vs.-
Kelly Jaeger, Individually and as Personal Representative of the Estate of Michael F. Platz, Deceased; Shannon Platz; Unknown Spouse of Kelly Jaeger; Unknown Spouse of Shannon Platz; Julia K. Platz; Unknown Parties in Possession #1, If living, and all Unknown Parties claiming by, through, under and against the above named Defendant(s) who are not known to be dead or alive, whether said Unknown Parties may claim an interest as Spouse, Heirs, Devisees, Grantees, or Other Claimants; Unknown Parties in Possession #2, If living, and all Unknown Parties claiming by, through, under and against the above named Defendant(s) who are not known to be dead or alive, whether said Unknown Parties may claim an interest as Spouse, Heirs, Devisees, Grantees, or Other Claimants Defendant(s).

TO: Shannon Platz: LAST KNOWN ADDRESS, 2482 Lake Debra Drive, Apt. 4206, Orlando, FL 32835 and Unknown Spouse of Shannon Platz: LAST KNOWN ADDRESS, 2482 Lake Debra Drive, Apt. 4206, Orlando, FL 32835

Residence unknown, if living, including any unknown spouse of the said Defendants, if either has remarried and if either or both of said Defendants are dead, their respective unknown heirs, devisees, grantees, assignees, creditors, lienors, and trustees, and all other persons claiming by, through, under or against the named Defendant(s); and the aforementioned named Defendant(s) and such of the aforementioned unknown Defendants and such of the aforementioned unknown Defendants as may be infants, incompetents or otherwise not sui juris.

YOU ARE HEREBY NOTIFIED that an action has been commenced to foreclose a mortgage on the following real property, lying and being and situated in Pasco County, Florida, more particularly described as follows:

LOT 153, TANGLEWOOD TERRACE UNIT FOUR, ACCORDING TO THE MAP OR PLAT THEREOF, AS RECORDED IN PLAT BOOK 15, PAGE(S) 145, OF THE PUBLIC RECORDS OF PASCO COUNTY, FLORIDA.

more commonly known as 6737 Knightsbridge Drive, New Port Richey, FL 34653.
This action has been filed against you and you are required to serve a copy of your written defense, if any, upon SHAPIRO, FISHMAN & GACHÉ, LLP, Attorneys for Plaintiff, whose address is 4630 Woodland Corporate Blvd., Suite 100, Tampa, FL 33614, on or before 8/15/16 and file the original with the clerk of this Court either before service on Plaintiff's attorney or immediately there after; otherwise a default will be entered against you for the relief demanded in the Complaint.

If you are a person with a disability who needs any accommodation in order to participate in this proceeding, you are entitled, at no cost to you, to the provision of certain assistance. Please contact the ADA Coordinator; 14250 49th Street North, Clearwater, Florida 33762 (727) 453-7163 at least 7 days before your scheduled court appearance, or immediately upon receiving this notification of the time before the scheduled appearance is less than 7 days. If you are hearing or voice impaired, call 711.

WITNESS my hand and seal of this Court on the 5 day of July, 2016.

Paula S. O'Neil, Ph.D.,
Clerk & Comptroller
By: Carmella Hernandez
Deputy Clerk
SHAPIRO, FISHMAN & GACHÉ, LLP
Attorneys for Plaintiff
4630 Woodland Corporate Blvd.,
Suite 100
Tampa, FL 33614
16-299189 FCO1 NCM
July 15, 22, 2016 16-01991P

SECOND INSERTION

NOTICE OF SALE PURSUANT TO CHAPTER 45 IN THE CIRCUIT COURT OF THE 6th JUDICIAL CIRCUIT IN AND FOR PASCO COUNTY, FLORIDA CASE NO.: 2012-CA-003616-WS FEDERAL NATIONAL MORTGAGE ASSOCIATION, ("Fannie Mae") Plaintiff, vs.

WENDELL T. BRINSON, SR., ET AL., Defendant(s).

NOTICE OF SALE IS HEREBY GIVEN pursuant to a Uniform Final Judgment of Foreclosure dated June 16, 2016, and entered in Case No. 2012-CA-003616-WS of the Circuit Court of the 6th Judicial Circuit in and for Pasco County, Florida, wherein, FEDERAL NATIONAL MORTGAGE ASSOCIATION, ("Fannie Mae"), is Plaintiff, and WENDELL T. BRINSON, SR., ET AL., are the Defendants, the Office of Paula S. O'Neil, Pasco County Clerk of the Court will sell to the highest and best bidder for cash via online auction at www.pasco.realforeclose.com at 11:00 A.M. on the 10th day of August, 2016, the following described property as set forth in said Final Judgment, to wit:

Lot 69, SHAMROCK HEIGHTS, UNIT THREE according to the map or plat thereof as recorded in plat book 8, page 27, Public Records of Pasco County, Florida.
Property Address: 4548 Belfast Drive, New Port Richey, FL 34652
and all fixtures and personal property

located therein or thereon, which are included as security in Plaintiff's mortgage.

Any person claiming an interest in the surplus funds from the sale, if any, other than the property owner as of the date of the lis pendens must file a claim within 60 days after the sale.

If you are a person with a disability who needs any accommodation in order to participate in this proceeding, you are entitled, at no cost to you, to the provision of certain assistance. Please contact the Public Information Dept., Pasco County Government Center, 7530 Little Rd., New Port Richey, FL 34654; (727) 847-8110 (V) in New Port Richey; (352) 521-4274, ext 8110 (V) in Dade City, at least 7 days before your scheduled court appearance, or immediately upon receiving this notification if the time before the scheduled appearance is less than 7 days; if you are hearing impaired call 711. The court does not provide transportation and cannot accommodate for this service. Persons with disabilities needing transportation to court should contact their local public transportation providers for information regarding transportation services.

Dated this 12th day of July, 2016.
By: Jared Lindsey, Esq.
FBN: 081974

Clarfield, Okon, Salomone & Pincus, P.L.
500 S. Australian Avenue, Suite 730
West Palm Beach, FL 33401
Telephone: (561) 713-1400
Facsimile: (561) 713-1401
Email: pleadings@copslaw.com
July 15, 22, 2016 16-01994P

SECOND INSERTION

NOTICE OF FORECLOSURE SALE IN THE CIRCUIT COURT OF THE SIXTH JUDICIAL CIRCUIT OF FLORIDA IN AND FOR PASCO COUNTY GENERAL JURISDICTION DIVISION

CASE NO. 51-2016-CA-000026-ES
NATIONSTAR MORTGAGE LLC D/B/A CHAMPION MORTGAGE COMPANY, Plaintiff, vs.
MURIEL D. SELLERS, ET AL., Defendants.

NOTICE IS HEREBY GIVEN pursuant to a Summary Final Judgment of Foreclosure entered May 4, 2016 in Civil Case No. 51-2016-CA-000026-ES of the Circuit Court of the SIXTH Judicial Circuit in and for Pasco County, Dade City, Florida, wherein NATIONSTAR MORTGAGE LLC D/B/A CHAMPION MORTGAGE COMPANY is Plaintiff and MURIEL D. SELLERS, is a Defendant, the Clerk of Court will sell to the highest and best bidder for cash electronically at www.pasco.realforeclose.com in accordance with Chapter 45, Florida Statutes on the 8th day of August, 2016 at 11:00 AM on the following described property as set forth in said Summary Final Judgment, to-wit:

The South 208.71 feet of the West 208.71 feet of the Southwest 1/4 of the Southeast 1/4 of the Southeast 1/4 of Section 28, Township 24 South, Range 21 East, Pasco County, Florida LESS the right-of-way of How-

ard Avenue.
Any person claiming an interest in the surplus from the sale, if any, other than the property owner as of the date of the lis pendens, must file a claim within 60 days after the sale.

If you are a person with a disability who needs any accommodation in order to participate in this proceeding, you are entitled, at no cost to you to the provision of certain assistance. Within two (2) working days of your receipt of this (describe notice/order) please contact the Public Information Dept., Pasco County Government Center, 7530 Little Rd., New Port Richey, FL 34654; (727) 847-8110 (V) in New Port Richey; (352) 521-4274, ext. 8110 (V) in Dade City; via 1-800-955-8771 if you are hearing impaired. The court does not provide transportation and cannot accommodate for this service. Persons with disabilities needing transportation to court should contact their local public transportation providers for information regarding disabled transportation services.

Lisa Woodburn, Esq.
Fla. Bar No.: 11003
McCalla Raymer Pierce, LLC
Attorney for Plaintiff
225 E. Robinson St. Suite 155
Orlando, FL 32801
Phone: (407) 674-1850
Fax: (321) 248-0420
Email:
MRSservice@mccallaraymer.com
5037275
15-04681-5
July 15, 22, 2016 16-02001P

SECOND INSERTION

NOTICE OF ACTION IN THE CIRCUIT COURT OF THE SIXTH JUDICIAL CIRCUIT IN AND FOR PASCO COUNTY, FLORIDA CIVIL ACTION

CASE NO.:
51-2014-CA-004603-WS
S. BANK TRUST, N.A., AS TRUSTEE FOR LSF9 MASTER PARTICIPATION TRUST, Plaintiff, vs.

THE UNKNOWN HEIRS, DEVISEES, GRANTEES, ASSIGNEES, LIENORS, CREDITORS, TRUSTEES, OR OTHER CLAIMANTS CLAIMING BY, THROUGH, UNDER, OR AGAINST, MICHAEL C. MISION A/K/A MICHAEL CAS MISION, SR. A/K/A MICHAEL CAS MISION, DECEASED, et al,
Defendant(s).

SIERRA MAE MISION, AS AN HEIR OF THE ESTATE OF MICHAEL C. MISION A/K/A MICHAEL CAS MISION, SR. A/K/A MICHAEL CAS MISION, DECEASED
Last Known Address: Unknown
Current Address: Unknown
THE UNKNOWN HEIRS, DEVISEES, GRANTEES, ASSIGNEES, LIENORS, CREDITORS, TRUSTEES, OR OTHER CLAIMANTS CLAIMING BY, THROUGH, UNDER, OR AGAINST, MICHAEL C. MISION A/K/A MICHAEL CAS MISION, SR. A/K/A MICHAEL CAS MISION, DECEASED
Last Known Address: Unknown
Current Address: Unknown
ANY AND ALL UNKNOWN PARTIES CLAIMING BY, THROUGH, UNDER, AND AGAINST THE HEREIN NAMED INDIVIDUAL DEFENDANT(S) WHO ARE NOT KNOWN TO BE DEAD OR ALIVE, WHETHER SAID UNKNOWN PARTIES MAY CLAIM AN INTEREST AS SPOUSES, HEIRS, DEVISEES, GRANTEES, OR OTHER CLAIMANTS

Last Known Address: Unknown
Current Address: Unknown
YOU ARE NOTIFIED that an action to foreclose a mortgage on the following property in Pasco County, Florida: LOT 835 BEACON SQUARE UNIT EIGHT AS SHOWN ON PLAT RECORDED IN PLAT BOOK 9 PAGE 32 AND 32A OF

THE PUBLIC RECORDS OF PASCO COUNTY FLORIDA A/K/A 3622 CHESWICK DR, HOLIDAY, FL 34691

has been filed against you and you are required to serve a copy of your written defenses within 30 days after the first publication, if any, on Albertelli Law, Plaintiff's attorney, whose address is P.O. Box 23028, Tampa, FL 33623, and file the original with this Court either before 8-15-16 service on Plaintiff's attorney, or immediately thereafter; otherwise, a default will be entered against you for the relief demanded in the Complaint or petition.

This notice shall be published once a week for two consecutive weeks in the Business Observer.

**See the Americans with Disabilities Act

If you are a person with a disability who needs an accommodation in order to participate in this proceeding, you are entitled, at no cost to you, to the provision of certain assistance. Please contact:

Public Information Dept., Pasco County Government Center, 7530 Little Rd., New Port Richey, FL 34654
Phone: 727.847.8110 (voice) in New Port Richey 352.521.4274, ext 8110 (voice) in Dade City or 711 for the hearing impaired.

Contact should be initiated at least seven days before the scheduled court appearance, or immediately upon receiving this notification if the time before the scheduled appearance is less than seven days.

The court does not provide transportation and cannot accommodate such requests. Persons with disabilities needing transportation to court should contact their local public transportation providers for information regarding transportation services.

WITNESS my hand and the seal of this court on this 28 day of JUNE, 2016.
Paula S. O'Neil, Ph.D.,
Clerk & Comptroller
By: Denise Allie
Deputy Clerk

Albertelli Law
P.O. Box 23028
Tampa, FL 33623
MP - 15-179314
July 15, 22, 2016 16-01995P

SECOND INSERTION

NOTICE OF FORECLOSURE SALE IN THE CIRCUIT COURT OF THE SIXTH JUDICIAL CIRCUIT IN AND FOR PASCO COUNTY, FLORIDA GENERAL JURISDICTION DIVISION

Case No. 2015CA003085CAAXWS
Deutsche Bank National Trust Company, as Trustee for GSAMP Trust 2005-HE5,
Plaintiff, vs.

Gerry E. Holliman; Unknown Spouse of Gerry E. Holliman,
Defendants.

NOTICE IS HEREBY GIVEN pursuant to a Final Judgment of Foreclosure dated June 2, 2016, entered in Case No. 2015CA-003085CAAXWS of the Circuit Court of the Sixth Judicial Circuit, in and for Pasco County, Florida, wherein Deutsche Bank National Trust Company, as Trustee for GSAMP Trust 2005-HE5 is the Plaintiff and Gerry E. Holliman; Unknown Spouse of Gerry E. Holliman are the Defendants, that Paula O'Neil, Pasco County Clerk of Court will sell to the highest and best bidder for cash by electronic sale at www.pasco.realforeclose.com, beginning at 11:00 AM on the 27th day of July, 2016, the following described property as set forth in said Final Judgment, to wit:

LOT 33, TANGLEWOOD TERRACE UNIT ONE, ACCORDING TO MAP OR PLAT THEREOF AS RECORDED IN PLAT BOOK 10, PAGE 124 THROUGH 126, PUBLIC RECORDS OF PASCO

COUNTY, FLORIDA

Any person claiming an interest in the surplus from the sale, if any, other than the property owner as of the date of the lis pendens must file a claim within 60 days after the sale.

If you are a person with a disability who needs any accommodation in order to participate in this proceeding, you are entitled, at no cost to you, to the provision of certain assistance. Please contact the Public Information Dept., Pasco County Government Center, 7530 Little Rd., New Port Richey, FL 34654; (727) 847-8110 (V) in New Port Richey; (352) 521-4274, ext 8110 (V) in Dade City, at least 7 days before your scheduled court appearance, or immediately upon receiving this notification if the time before the scheduled appearance is less than 7 days; if you are hearing impaired call 711. The court does not provide transportation and cannot accommodate for this service. Persons with disabilities needing transportation to court should contact their local public transportation providers for information regarding transportation services.

Dated this 11 day of July, 2016.

By Kathleen McCarthy, Esq.
Florida Bar No. 72161
BROCK & SCOTT, PLLC
Attorney for Plaintiff
1501 N.W. 49th Street, Suite 200
Ft. Lauderdale, FL 33309
Phone: (954) 618-6955, ext. 6177
Fax: (954) 618-6954
FLCourtDocs@brockandscott.com
File # 15-F02287
July 15, 22, 2016 16-02019P

SECOND INSERTION

NOTICE OF FORECLOSURE SALE IN THE CIRCUIT COURT OF THE SIXTH JUDICIAL CIRCUIT OF FLORIDA IN AND FOR PASCO COUNTY GENERAL JURISDICTION DIVISION

CASE NO. 51-2014-CA-004760ES
REVERSE MORTGAGE SOLUTIONS, INC.,
Plaintiff, vs.
JAMES L. OLSON, ET AL.
Defendants.

NOTICE IS HEREBY GIVEN pursuant to a Summary Final Judgment of Foreclosure entered June 24, 2016 in Civil Case No. 51-2014-CA-004760ES of the Circuit Court of the SIXTH Judicial Circuit in and for Pasco County, Dade City, Florida, wherein REVERSE MORTGAGE SOLUTIONS, INC. is Plaintiff and JAMES L. OLSON, et al., are Defendants, the Clerk of Court will sell to the highest and best bidder for cash electronically at www.pasco.realforeclose.com in accordance with Chapter 45, Florida Statutes on the 1st day of August, 2016 at 11:00 AM on the following described property as set forth in said Summary Final Judgment, to-wit:

LOT 21, BLOCK 4 LAKE BERNADATTE - PARCEL 11 PHASE 1 ACCORDING TO THE PLAT RECORDED IN PLAT BOOK 38 PAGES 77, OF THE PUBLIC RECORDS OF PASCO COUNTY, FLORIDA, SAID LAND SITUATE, LYING AND

BEING IN PASCO COUNTY, FLORIDA.

Any person claiming an interest in the surplus from the sale, if any, other than the property owner as of the date of the lis pendens, must file a claim within 60 days after the sale.

If you are a person with a disability who needs any accommodation in order to participate in this proceeding, you are entitled, at no cost to you to the provision of certain assistance. Within two (2) working days of your receipt of this (describe notice/order) please contact the Public Information Dept., Pasco County Government Center, 7530 Little Rd., New Port Richey, FL 34654; (727) 847-8110 (V) in New Port Richey; (352) 521-4274, ext. 8110 (V) in Dade City; via 1-800-955-8771 if you are hearing impaired. The court does not provide transportation and cannot accommodate for this service. Persons with disabilities needing transportation to court should contact their local public transportation providers for information regarding disabled transportation services.

Lisa Woodburn, Esq.
Fla. Bar No.: 11003
McCalla Raymer Pierce, LLC
Attorney for Plaintiff
225 E. Robinson St. Suite 155
Orlando, FL 32801
Phone: (407) 674-1850
Fax: (321) 248-0420
Email:
MRSservice@mccallaraymer.com
5026166
14-07888-4
July 15, 22, 2016 16-02000P

SECOND INSERTION

NOTICE OF FORECLOSURE SALE IN THE CIRCUIT COURT OF THE SIXTH JUDICIAL CIRCUIT IN AND FOR PASCO COUNTY, FLORIDA GENERAL JURISDICTION DIVISION

Case No.
512014CA003315CAAXWS
Wells Fargo Bank, NA,
Plaintiff, vs.

WILLIAM G. JONES; JANET A. JONES; Any And All Unknown Parties Claiming By, Through, Under, And Against The Herein Named Individual Defendant(S) Who Are Not Known To Be Dead Or Alive, Whether Said Unknown Parties May Claim An Interest As Spouses, Heirs, Devisees, Grantees, Or Other Claimants; WELLS FARGO BANK, NATIONAL ASSOCIATION, AS SUCCESSOR BY MERGER TO WACHOVIA BANK, NATIONAL ASSOCIATION; BEACON WOODS EAST MASTER ASSOCIATION, INC.; BEACON WOODS EAST RECREATION ASSOCIATION, INC.; BARRINGTON WOODS AT BEACON WOODS EAST ASSOCIATION, INC.; Tenant #1; Tenant #2; Tenant #3; and Tenant #4 the name being fictitious to account for parties in possession, Defendants.

NOTICE IS HEREBY GIVEN pursuant to an Order dated June 8, 2016, entered in Case No. 512014CA003315CAAXWS of the Circuit Court of the Sixth Judicial Circuit, in and for Pasco County, Florida, wherein Wells Fargo Bank, NA is the Plaintiff and WILLIAM G. JONES; JANET A. JONES; Any And All Unknown Parties Claiming By, Through, Under, And Against The Herein Named Individual Defendant(S) Who Are Not Known To Be Dead Or Alive, Whether Said Unknown Parties May Claim An Interest As Spouses, Heirs, Devisees, Grantees, Or Other Claimants; WELLS FARGO BANK, NATIONAL ASSOCIATION, AS SUCCESSOR BY MERGER TO WACHOVIA BANK, NATIONAL ASSOCIATION; BEACON WOODS EAST MASTER ASSOCIATION, INC.; BEACON WOODS EAST RECREATION ASSOCIATION, INC.; BARRINGTON WOODS AT BEACON

WOODS EAST ASSOCIATION, INC.; Tenant #1; Tenant #2; Tenant #3; and Tenant #4 the name being fictitious to account for parties in possession are the Defendants, that Paula O'Neil, Pasco County Clerk of Court will sell to the highest and best bidder for cash by electronic sale at www.pasco.realforeclose.com, beginning at 11:00 AM on the 28th day of July, 2016, the following described property as set forth in said Final Judgment, to wit:

LOT 98, BARRINGTON WOODS, PHASE 2, ACCORDING TO THE MAP OR PLAT THEREOF RECORDED IN PLAT BOOK 28, PAGES 1-3, PUBLIC RECORDS OF PASCO COUNTY, FLORIDA.

Any person claiming an interest in the surplus from the sale, if any, other than the property owner as of the date of the lis pendens must file a claim within 60 days after the sale.

If you are a person with a disability who needs any accommodation in order to participate in this proceeding, you are entitled, at no cost to you, to the provision of certain assistance. Please contact the Public Information Dept., Pasco County Government Center, 7530 Little Rd., New Port Richey, FL 34654; (727) 847-8110 (V) in New Port Richey; (352) 521-4274, ext 8110 (V) in Dade City, at least 7 days before your scheduled court appearance, or immediately upon receiving this notification if the time before the scheduled appearance is less than 7 days; if you are hearing impaired call 711. The court does not provide transportation and cannot accommodate for this service. Persons with disabilities needing transportation to court should contact their local public transportation providers for information regarding transportation services.

Dated this 11 day of July, 2016.
By Kathleen McCarthy, Esq.
Florida Bar No. 72161
BROCK & SCOTT, PLLC
Attorney for Plaintiff
1501 N.W. 49th Street, Suite 200
Ft. Lauderdale, FL 33309
Phone: (954) 618-6955, ext. 6177
Fax: (954) 618-6954
FLCourtDocs@brockandscott.com
File # 16-F01405
July 15, 22, 2016 16-02022P

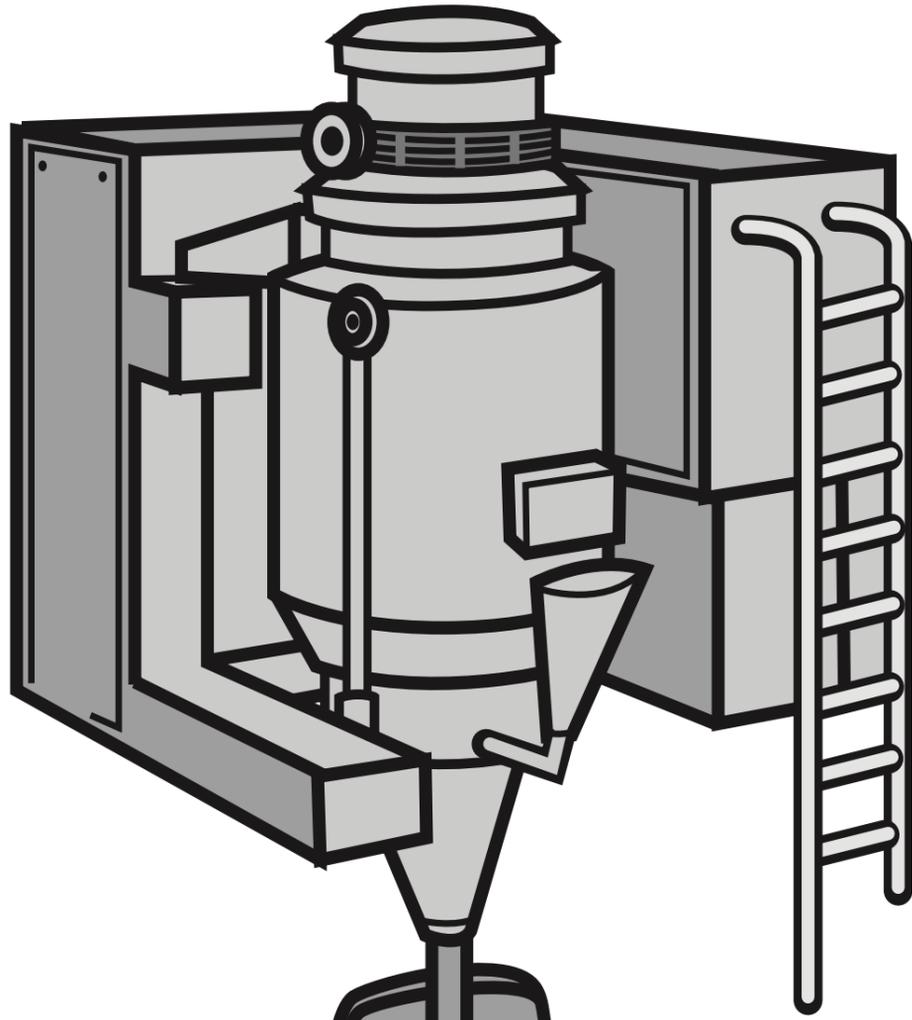

A special printing of a classic story illustrating the importance of protecting capitalism.

TOM SMITH AND HIS INCREDIBLE BREAD MACHINE

By R.W. Grant

Illustrations by Austin McKinley

This is the legend of a man whose name
Was a household word: a man whose fame
Burst on the world like an atom bomb.
Smith was his last name; first name: Tom.

The argument goes on today.
"He was a villain," some will say.
"No! A hero!" others declare.
Or was he both? Well, I despair;
The fight will last 'til kingdom come;
Was Smith a hero? Or was Smith a bum?
So, listen to the story and it's up to you
To decide for yourself as to which is true!

Now, Smith, an inventor, had specialized
In toys. So people were surprised
When they found that he instead
Of making toys, was baking bread!
The news was flashed by CBS
Of his incredible success.
Then NBC jumped in in force,
Followed by the Times, of course.
The reason for their rapt attention,
The nature of his new invention,
The way to make bread he'd conceived
Cost less than people could believe!
And not just make it! This device
Could in addition wrap and slice!
The price per loaf, one loaf or many:
The miniscule sum of under one penny!

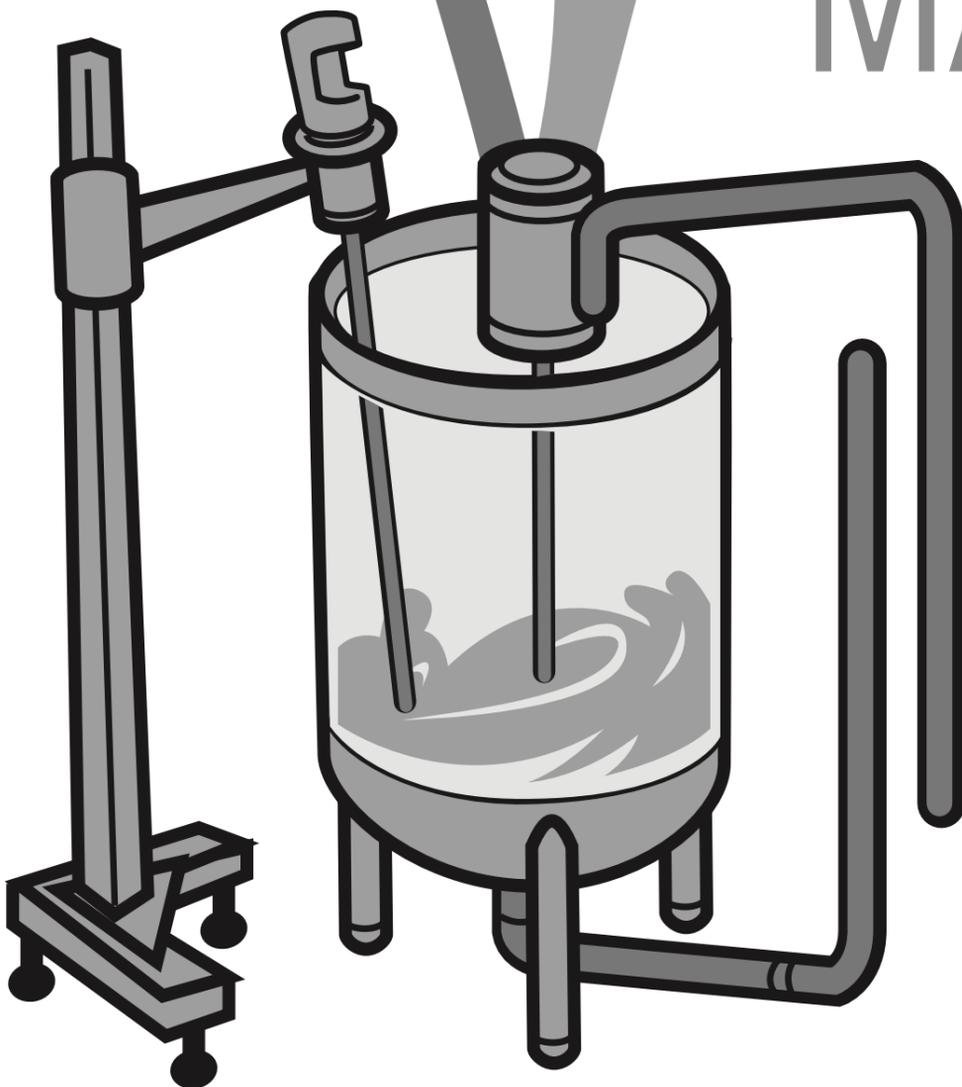

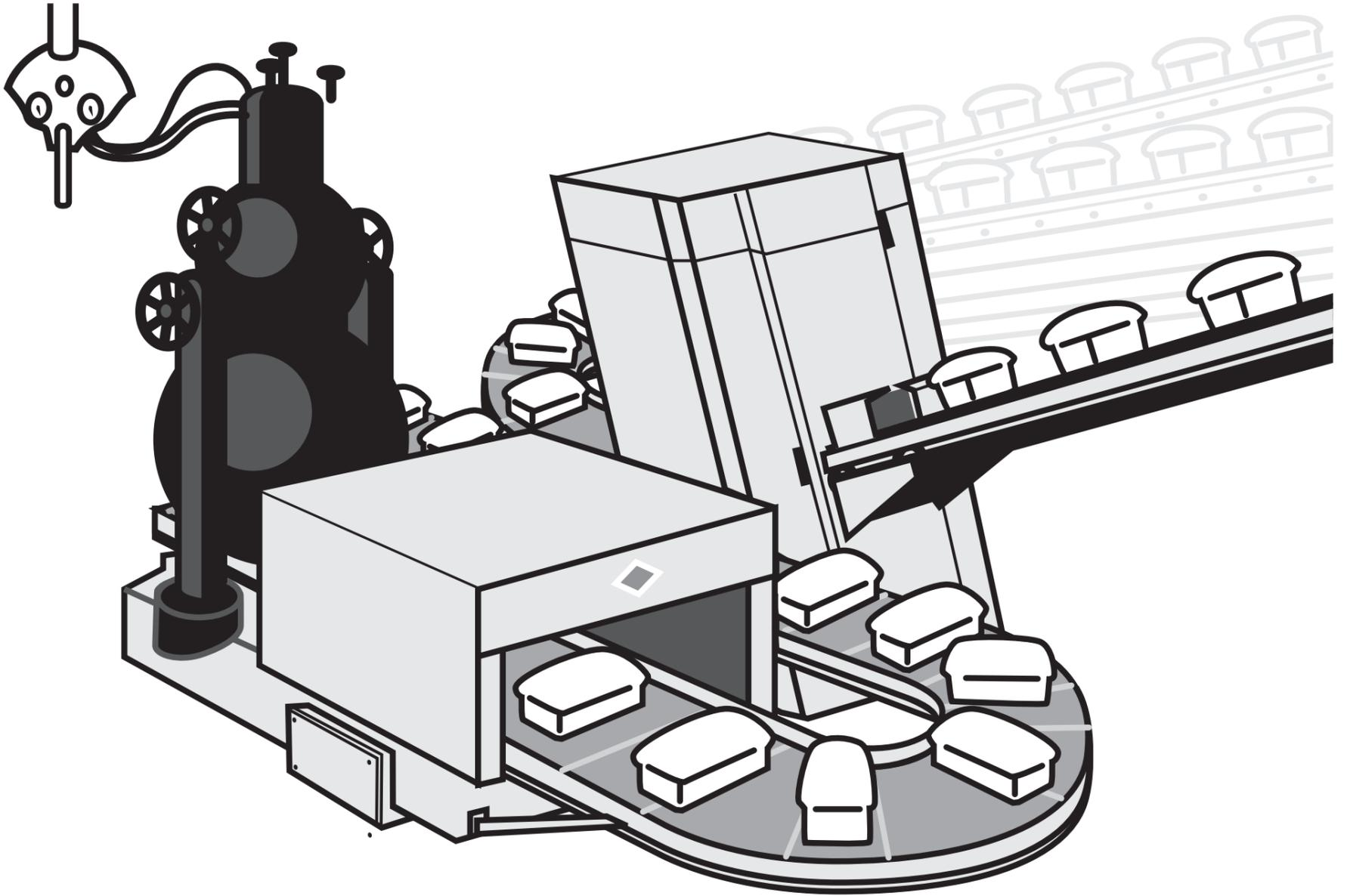

Can you imagine what this meant?
Can you comprehend the consequent?
The first time yet the world well fed!
And all because of Tom Smith's bread!

Not the last to see the repercussions
Were the Red Chinese, and, of course, the
Russians,
For Capitalist bread in such array

Threw the whole red block into black dis-
may!
Nonetheless, the world soon found
That bread was plentiful the world
around.
Thanks to Smith and all that bread,
A grateful world was at last well fed!

But isn't it a wondrous thing
How quickly fame is flown?
Smith, the hero of today
Tomorrow, scarcely known!
Yes, the fickle years passed by.
Smith was a billionaire.

But Smith himself was now forgot,
Though bread was everywhere.
People, asked from where it came,
Would very seldom know.

They would simply eat and ask,
'Was not it always so?'

However, Smith cared not a bit,
For millions ate his bread,
And "Everything is fine," thought he.
'I'm rich and they are fed!'

Everything was fine, he thought?
He reckoned not with fate.
Note the sequence of events
Starting on the date
On which inflation took its toll,
And to a slight extent,
The price on every loaf increased:
It went to one full cent!

A sharp reaction quickly came.
People were concerned.
White House aide expressed dismay.
Then the nation learned
That Russia lodged a sharp protest.
India did the same.
"Exploitation of the Poor!"
Yet, who was there to blame?

And though the clamor ebbed and flowed,
All that Tom would say
Was that it was but foolish talk.
Which soon would die away.
And it appeared that he was right.
Though on and on it ran,
The argument went 'round and 'round
But stopped where it began.

There it stopped, and people cried,
"For heaven's sake, we can't decide!
It's relative! Beyond dispute,
There's no such thing as 'absolute'!
And though we try with all our might,
Since nothing's ever black or white,
All that we can finally say is
'Everything one shade of grey is!'
So people cried out, "Give us light!
We can't tell what's wrong from right!"

To comprehend confusion,
We seek wisdom at its source.
To whom, then did the people turn?
The Intellectuals, of course!

And what could be a better time
For them to take the lead,
Than at their International Conference
On Inhumanity and Greed.
For at this weighty conference,
Once each year we face
The moral conscience of the world—
Concentrated in one place.

At that mighty conference were
A thousand, more or less,
Of intellectuals and bureaucrats,
And those who write the press.
And from Yale and Harvard
The professors; all aware
The fate of Smith would now be known.
Excitement filled the air!

"The time has come," the chairman said
"To speak of many things:
Of duty, bread and selfishness,
And the evil that it brings.
For, speaking thus we can amend
That irony of fate
That gives to unenlightened minds
The power to create.



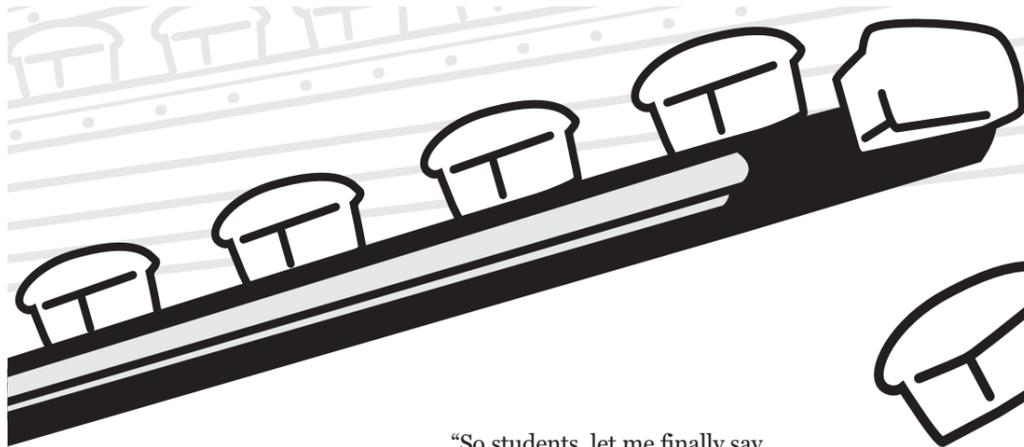

“Since reason tells us that it can’t,
Therefore let us start
Not by thinking with the mind,
But only with the heart!
Since we believe in people, then,
At last the chairman said,
‘We must meet our obligation
To see that they are fed!’”

And so it went, one by one,
Denouncing private greed;
Denouncing those who’d profit thus
From other people’s need!

Then, suddenly each breath was held,
For there was none more wise
Than the nation’s foremost Pundit
Who now rose to summarize:

“My friends,” he said, (they all
exhaled)
‘We see in these events
The flouting of the Higher Law—
And its consequence.
We must again remind ourselves
Just why mankind is cursed:
Because we fail to realize
Society comes first!’

“Smith placed himself above the
group
To profit from his brothers.
He failed to see the Greater Good,
Is Service, friends, to Others!”

With boldness and with vision,
then,
They ratified the motion
To dedicate to all mankind
Smith’s bread—and their devotion!

The conference finally ended.
It had been a huge success.
The intellectuals had spoken.
Now others did the rest.

The professors joined in all the
fuss,
And one was heard to lecture thus:
(For clarity, he spoke in terms
Of Mother Nature, birds and worms):

“That early birds should get the worm
Is clearly quite unfair.
Wouldn’t it much nicer be
If all of them would share?
But selfishness and private greed

Seem part of nature’s plan,
Which Mother Nature has decreed
For bird. But also Man?
The system which I question now,
As you are well aware,
(I’m sure you’ve heard the term
before
Is Business, Laissez-Faire!

“So students, let me finally say
That we must find a nobler way.
So, let us fix the race that all
May finish side-by-side;
The playing field forever flat,
The score forever tied.
To achieve this end, of course,
We turn to government—and force.
So, if we have to bring Smith do
As indeed we should,
I’m sure you will agree with me,
It’s for the Greater Good!”

Comments in the nation’s press
Now scorned Smith and his plunder:
‘What right had he to get so rich
On other people’s hunger?’
A prize cartoon depicted Smith
With fat and drooping jowls
Snatching bread from hungry babes,
Indifferent to their howls.

One night, a TV star cried out,
“Forgive me if I stumble,
But I don’t think, I kid you not,
That Smith is very humble!”
Growing bolder, he leaped up,

(Silencing the cheers)
“Humility!” he cried to all—
And then collapsed in tears!

The clamor rises all about;
Now hear the politician shout:
‘What’s Smith done, so rich to be?
Why should Smith have more than thee?
So, down with Smith and all his greed;
I’ll protect your right to need!’”

Then Tom found to his dismay
That certain businessmen would say,
“The people now should realize
It’s time to cut Smith down to size,
For he’s betrayed his public trust
(And taken all that bread from us!)”

Well, since the Public does come first,
It could not be denied
That in matters such as this,
The public must decide.
So, SEC became concerned,
And told the press what it had learned:
“It’s obvious that he’s guilty
—Of what we’re not aware—
Though actually and factually
We’re sure there’s something there!”

And Antitrust now took a hand.
Of course it was appalled
At what it found was going on.
The “bread trust” it was called.

“Smith has too much crust,”
they said. “A deplorable condition
That Robber Barons profit thus
From cutthroat competition!”

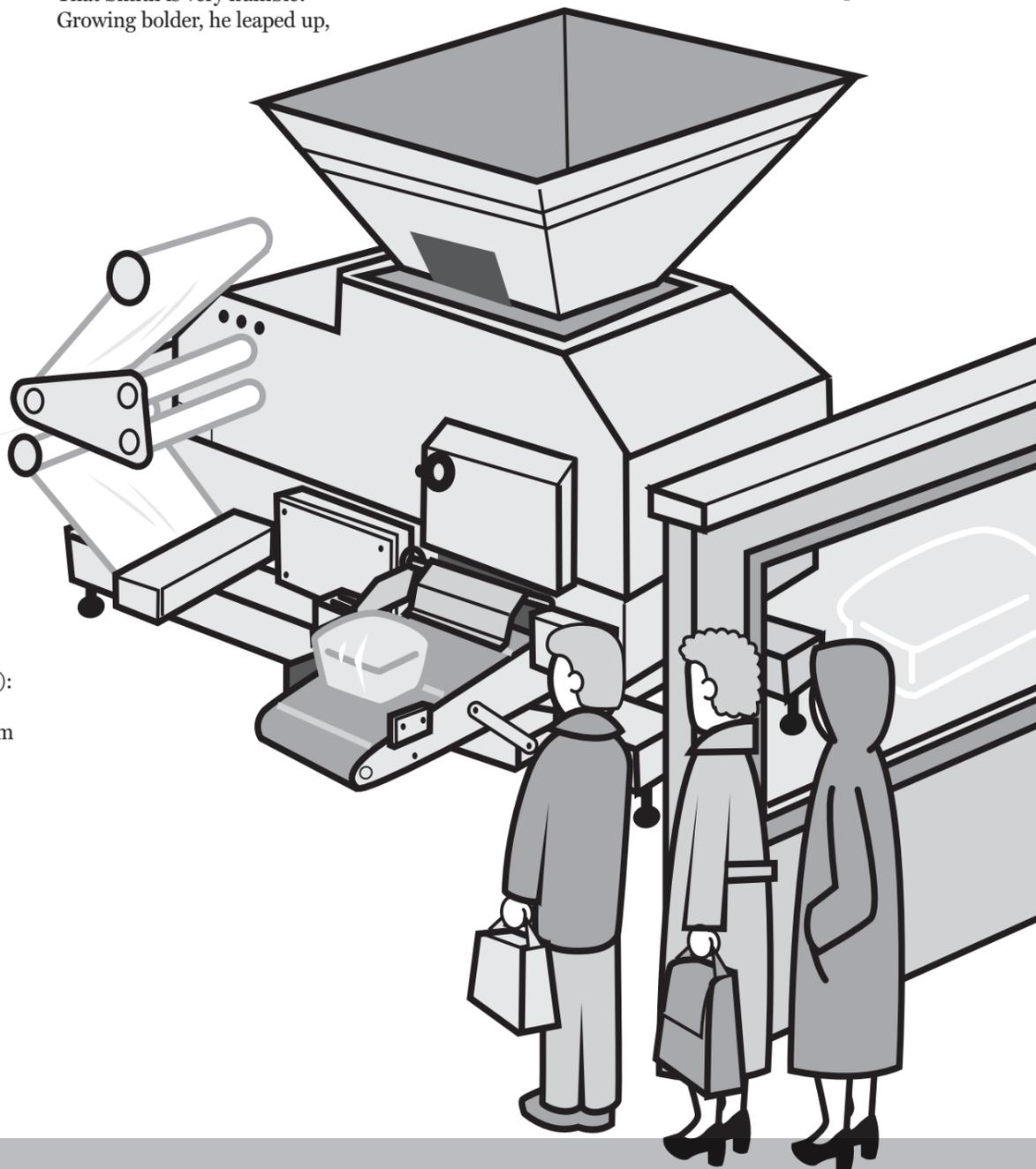

WELL!

This was getting serious!
So Smith felt that he must
Have a friendly interview
With SEC and 'Trust.
So, hat in hand, he went to them.
They'd surely been misled;
No rule of law had he defied.
But then their lawyer said:

"The rule of law, in complex times,
Has proved itself deficient.
We much prefer the rule of men.
It's vastly more efficient.

"So, nutshell-wise, the way it is,
The law is what we say it is!

"So, let me state the present rules,"
The lawyer then went on,
"These very simple guidelines
You can rely upon:
You're gouging on your prices
If you charge more than the rest.
But it's unfair competition
If you think you can charge less!
"A second point that we would make,
To help avoid confusion:
Don't try to charge the same amount,
For that would be collusion!"

"You must compete—but not too much.
For if you do, you see,
Then the market would be yours—
And that's monopoly!
Oh, don't dare monopolize!
We'd raise an awful fuss,
For that's the greatest crime of all!
(Unless it's done by us!)"

"I think I understand," said Tom.
"And yet, before I go,
How does one get a job like yours?
I'd really like to know!"

The lawyer rose then with a smile;
"I'm glad you asked," said he.
"I'll tell you how I got my start
And how it came to be."

(His secretaries gathered 'round
As their boss did thus expound.)

*"When I was a lad going off to school,
I was always guided by this golden rule:
Let others take the lead in things, for
heaven's sake,
So if things go wrong-why, then it's their
mistake!"*
(*So if things go wrong-why, then it's their
mistake!*)

*"Following this precept it came to pass
I became the president of my senior class.
Then on to college where my profs extolled
The very same theory from the very same
mold!"*
(*The very same theory from the very same
mold!*)

*"Let others take the chances, and I would
go along.
Then I would let them know where they all
went wrong!
So successful was my system that then
indeed,
I was voted most likely in my class to suc-
ceed!"*

*(He was voted most likely in his class to
succeed!)*

*"Then out into the world I went, along
with all the rest,
Where I put my golden rule to the ulti-
mate test.
I avoided all of commerce at whatever the
cost—
And because I never ventured, then I also
never lost!"*
(*And because he never ventured, then he
also never lost!*)

*"With this unblemished record then, I
quickly caught the eye
Of some influential people 'mongst the
powers on high.*

*And so these many years among the
mighty I have sat,
Having found my niche as a bureaucrat!"*
(*Having found his niche as a bureaucrat*)

*"To be a merchant prince has never been
my goal,
For I'm qualified to play a more impor-
tant role:
Since I've never failed in business, this of
course assures
That I'm qualified beyond dispute to now
run yours!"*
(*That he's qualified beyond dispute to now
run yours!*)

"Thanks; that clears it up," said Tom.

The lawyer said, "I'm glad!
We try to serve the public good.
We're really not so bad!"

"Now, in disposing of this case,
If you wish to know just how,
Go up to the seventh floor;
We're finalizing now!"

So, Tom went to the conference room
Up on the seventh floor.
He raised his hand, about to knock,
He raised it—but no more—
For what he overheard within
Kept him outside the door!
A sentence here, a sentence there—
Every other word—
He couldn't make it out (he hoped),
For this is what he heard:

"Mumble, mumble, let's not fumble!
Mumble, mumble, what's the charge?
Grumble, grumble, he's not humble?
Private greed? Or good of all?"

"Public Interest, Rah! Rah! Rah!
Business, Business, Bah! Bah! Bah!"

"Say, now this now we confess
That now this now is a mess!
Well now, what now do we guess?
Discharge? Which charge would be best?"

"How 'bout 'Greed and Selfishness'?
Oh, wouldn't that be fun?
It's vague enough to trip him up
No matter what he's done!"

"We don't produce or build a thing!
But before we're through,
We allow that now we'll show Smith how
We handle those who do!"

"We serve the public interest;
We make up our own laws;
Oh, golly gee, how selflessly
We serve the public cause!"

"For we're the ones who make the rules
At 'Trust and SEC,
So bye and bye we'll get that guy;
Now, what charge will it be?"

"Price too high? Or price too low?
Now, which charge will we make?
Well, we're not loath to charging both
When public good's at stake!"

"But can we go one better?
How 'bout monopoly?
No muss, no fuss, oh clever us!
Right-O! Let's charge all three!"

"But why stop here? We have one more!
Insider Trading! Number four!
We've not troubled to define
This crime in any way so,
This allows the courts to find
Him guilty 'cause we say so!"

So, that was the indictment.
Smith's trial soon began.
It was a cause célèbre
Which was followed' cross the land.
In his defense Tom only said,
"I'm rich, but all of you are fed!
Is that bargain so unjust
That I should now be punished thus?"

Tom fought it hard all the way.
But it didn't help him win.
The jury took but half an hour
To bring this verdict in:

"Guilty! Guilty! We agree!
He's guilty of this plunder!
He had no right to get so rich
On other people's hunger!"

"Five years in jail!" the judge then said.
"You're lucky it's not worse!
Robber Barons must be taught
Society Comes First!
As flies to wanton boys," he leered,
"Are we to men like these!
They exploit us for their sport!
Exploit us as they please!"

The sentence seemed a bit severe,
But mercy was extended.
In deference to his mother's pleas,
One year was suspended.
And what about the Bread Machine?
Tom Smith's little friend?
Broken up and sold for scrap.
Some win. Some lose. The end.

EPILOGUE

Now, bread is baked by government.
And as might be expected,
Everything is well controlled—
The public well protected.

True, loaves cost ten dollars each.
But our leaders do their best.
The selling price is half a cent.
Taxes pay the rest!

