

Find your notices online at: OrangeObserver.com,
FloridaPublicNotices.com and
BusinessObserverFL.com

THURSDAY, SEPTEMBER 24, 2020

ORANGE COUNTY LEGAL NOTICES

FIRST INSERTION

NOTICE OF ACTION FOR DISSOLUTION OF MARRIAGE IN THE CIRCUIT COURT FOR THE NINTH JUDICIAL CIRCUIT IN AND FOR ORANGE COUNTY, FLORIDA
Case No.: 2020-DR-6608A
Division: 03

In re: The Marriage of: HERBERT LEE BYRD, JR., Petitioner, and KAMILAH AUDREY BYRD, Respondent.
TO: KAMILAH AUDREY BYRD
925 Oasis Palm Circle
Ocoee, Florida 34761
Respondent.

YOU ARE NOTIFIED that an action for Dissolution of Marriage has been filed against you and that you are required to serve a copy of your written defenses, if any, to it on HERBERT LEE BYRD c/o TYRONE WATSON LAW, P.A., whose address is P.O. BOX 160876 ALTAMONTE SPRINGS, FLORIDA, 32716 on or before October 14, 2020 and file the original with the clerk of this Court 425 N. Orange Avenue Orlando, Florida 32801, on or before October 14, 2020, before service on Petitioner or immediately thereafter. If you fail to do so, a default may be entered against you for the relief demanded in the petition.

Copies of all court documents in this case, including orders, are available at the Clerk of the Circuit Court's office. You may review these documents upon request.

You must keep the Clerk of the Circuit Court's office notified of your current address. (You may file Designation of Current Mailing and E-Mail Address, Florida Supreme Court Approved Family Law Form 12.915.) Future papers in this lawsuit will be mailed or e-mailed to the address(es) on record at the clerk's office.

WARNING: Rule 12.285, Florida Family Law Rules of Procedure, requires certain automatic disclosure of documents and information. Failure to comply can result in sanctions, including dismissal or striking of pleadings.

Date: September 24, 2020
CLERK OF THE CIRCUIT COURT
By: Deputy Clerk
Sep. 24; Oct. 1, 8, 15, 2020
20-03675W

FIRST INSERTION

NOTICE OF SALE Rainbow Title & Lien, Inc. will sell at Public Sale at Auction the following vehicles to satisfy lien pursuant to Chapter 713.78 of the Florida Statutes on October 08, 2020 at 10 A.M. *Auction will occur where each Vehicle is located* 2002 Volkswagon VIN# 3VWCP-21C82M411060, 1999 Jeep VIN# 1J4GW68N7XC807389, 2010 Scion, VIN# JTKKU4B43A1003743, 2017 Nissan VIN# 1N4AA6APX-HC385907, 2007 Honda VIN# 1HGCM72387A022304, 2012 Nissan VIN# 3N1AB6APOCL751333, 2007 Toyota VIN# 5TENX22NX7Z447578 Located at: 9800 Bachman Rd, Orlando, FL 32824; 2017 Dodge VIN# 2C4RDGC-G5HR841813 Located at: 11801 West Colonial Dr, Ocoee, FL 34761 Any person(s) claiming any interest(s) in the above vehicles contact: Rainbow Title & Lien, Inc., (954) 920-6020 *All Auctions Are Held With Reserve* Some of the vehicles may have been released prior to auction LIC # AB-0001256
September 24, 2020 20-03678W

FIRST INSERTION

NOTICE OF PUBLIC SALE: Universal Towing & Recovery gives Notice of Lien and intent to sell these vehicles at 8:00 a.m. at 206 6th Street, Orlando, FL. 32824 pursuant to subsection 713.78 of the Florida Statutes. Universal Towing & Recovery reserves the right to accept or reject any and/or all bids. 2002 MERZ VIN# WDBPJ75J92A024010 SALE DATE 10/23/2020 1995 FORD VIN# 1FTCR10U2SPA00071 SALE DATE 10/23/2020 2003 TOYO VIN# 4T1BE32K73U216947 SALE DATE 10/23/2020 2015 JEEP VIN# 1C4PJLAB2FW560928 SALE DATE 10/23/2020 2012 NISS VIN# 1N4AL2AP6CN546883 SALE DATE 10/23/2020 2001 MERC VIN# 4M2ZV14T01DJ00414 SALE DATE 10/23/2020 1999 DODG VIN# 2B3HD56J7XH548010 SALE DATE 10/23/2020 2018 JEEP VIN# 1C4PJLCB3JD590554 SALE DATE 11/7/2020
September 24, 2020 20-03723W

FIRST INSERTION

NOTICE OF PUBLIC SALE Pursuant to F.S. 713.78, Airport Towing Service will sell the following vehicles and/or vessels. Seller reserves the right to bid. Sold as is, no warranty. Seller guarantees no title, terms cash. Seller reserves the right to refuse any or all bids.

SALE DATE 10/05/2020, 11:00 AM

Located at 6690 E. Colonial Drive, Orlando FL 32807:

2014 DODGE
1C3CFAA8ED740590

SALE DATE 10/06/2020, 11:00 AM

Located at 6690 E. Colonial Drive, Orlando FL 32807:

2013 CHEVROLET
1GC1CVCG7DF203939
1999 HONDA
1HGEJ6676XL053404
1900 INTERNATIONAL FLATBED
NO VIN

Located at: 4507 E. Wetherbee Rd, Orlando, FL 32824

2009 KIA
KNDMB233496303273

SALE DATE 10/09/2020, 11:00 AM

Located at 6690 E. Colonial Drive, Orlando FL 32807:

2002 CHRYSLER
3C8FY68B22T201785
2000 HONDA
1HGCG6658YA151142
2005 NISSAN
JN8AZ08TX5W318533
1998 HONDA
1HGCG5548WA083733

Located at: 4507 E. Wetherbee Rd, Orlando, FL 32824

2002 NISSAN
JN8DR09X82W665871
2004 HYUNDAI
KM8SC13D14U765796
September 24, 2020 20-03676W

FIRST INSERTION

Notice of Public Auction Pursuant to Ch 713.585(6) F.S. United American Lien & Recovery as agent w/ power of attorney will sell the following vehicle(s) to the highest bidder; net proceeds deposited with the clerk of court; owner/lienholder has right to hearing and post bond; owner may redeem vehicle for cash sum of lien; all auctions held in reserve
Inspect 1 week prior @ lienor facility; cash or cashier check; 28% buyer premium; any person interested ph (954) 563-1999
Sale date October 16, 2020 @ 10:00 am 3411 NW 9th Ave Ft Lauderdale FL 33309
35073 2017 Nissan VIN#: 1N4AL3AP6HC271461 Lienor: Orlando Garage Auto Inc 1502 Grand St Orlando 407-649-6569 Lien Amt \$9685.57
Sale Date October 23, 2020 @ 10:00 am 3411 NW 9th Ave #707 Ft Lauderdale FL 33309
35095 2005 Dodge VIN#: 1B3ES-56C15D279541 Lienor: Lino Auto Repair Inc 6214 All American Blvd Orlando 407-578-9880 Lien Amt \$3153.93
Licensed Auctioneers
FLAB422 FLAU 765 & 1911
September 24, 2020 20-03679W

FIRST INSERTION

Notice Under Fictitious Name Law According to Florida Statute Number 865.09
NOTICE IS HEREBY GIVEN that the undersigned, desiring to engage in business under the Fictitious Name of Winter Park Massage and Wellness located at 2100 Lee Rd, Suite F in the City of Winter Park, Orange County, FL 32789 intends to register the said name with the Division of Corporations of the Florida Department of State, Tallahassee, Florida. Dated this 17th day of September, 2020.
Roots 2 Wellness, LLC
September 24, 2020 20-03687W

FIRST INSERTION

NOTICE OF PUBLIC SALE. Notice is hereby given that the following vehicles will be sold at public auction pursuant to F.S. 713.78 on the sale dates at the locations below at 9:00 a.m. to satisfy towing and storage charges.
1988 ISUZU
JALM7A1N1J3201093
Sale Date: 10/13/2020
Location: Wonder World Express Towing and Storage LLC
308 Ring Rd
Orlando, FL 32811
Lienors reserve the right to bid.
September 24, 2020 20-03777W

FIRST INSERTION

NOTICE OF SALE Rainbow Title & Lien, Inc. will sell at public sale at auction the following vehicles to satisfy lien pursuant to Chapter 713.585 of the Florida Statutes 10/08/2020 at 10 A.M. *Auction will occur where vehicles are located* 2014 Kia VIN# 5XYKT3A69EG48338 Amount: \$3,535.25 At: 3407 W Colonial Dr, Orlando, FL Notice to the Owner or Lienor that he has the right to a hearing prior to the scheduled date of sale by filing with the Clerk of Courts. Owner has the right to recover possession of vehicle by posting bond in accordance with Fla. Statutes Sect. 559.917 Proceeds from the sale of the vehicle after payment lien claimed by lienor will be deposited with the clerk of the court. Any person (s) claiming any interest(s) in the above vehicles contact: RAINBOW TITLE & LIEN, INC. (954-920-6020) ALL AUCTIONS ARE HELD WITH RESERVE. 25% Buyers Premium Some vehicles may have been released prior to the sale date. Lic# AB-000125
Interested Parties must call one day prior to sale.
September 24, 2020 20-03677W

FIRST INSERTION

Notice Under Fictitious Name Law Pursuant to Section 865.09, Florida Statutes
NOTICE IS HEREBY GIVEN that the undersigned, desiring to engage in business under fictitious name of West Orange Veterinary Hospital at Hamlin located at 15820 Shaddock Dr. Suite 100, in the County of Orange, in the City of Winter Garden, Florida 34787, intends to register the said name with the Division of Corporations of the Florida Department of State, Tallahassee, Florida. Dated at Orange, Florida, this 16th day of September, 2020.
ZBS West Orange Veterinary Hospital, LLC
September 24, 2020 20-03688W

FIRST INSERTION

FICTITIOUS NAME NOTICE Notice is hereby given that JOHN DAVID JEBBAILEY, CHARLOTTE JEBBAILEY, OWNERS, desiring to engage in business under the fictitious name of FBC ROOFING OF CENTRAL FLORIDA located at 1202 JOHNS COVE LN, OAKLAND, FLORIDA 34787 intends to register the said name in ORANGE county with the Division of Corporations, Florida Department of State, pursuant to section 865.09 of the Florida Statutes.
September 24, 2020 20-03690W

FIRST INSERTION

NOTICE OF PUBLIC HEARING CITY OF WINTER GARDEN, FLORIDA Pursuant to the Florida Statutes, notice is hereby given that the City of Winter Garden City Commission will, on October 8, 2020 at 6:30 p.m. or as soon after as possible, hold a public hearing in the City Commission Chambers located at 300 West Plant Street, Winter Garden, Florida in order to consider the adoption of the following ordinance(s):
ORDINANCE 20-42

AN ORDINANCE OF THE CITY OF WINTER GARDEN, FLORIDA AMENDING THE FUTURE LAND USE MAP OF THE WINTER GARDEN COMPREHENSIVE PLAN BY CHANGING THE LAND USE DESIGNATION OF REAL PROPERTY GENERALLY DESCRIBED AS APPROXIMATELY 1.96 +/- ACRES LOCATED AT 15411, 15540, 15541 E OAKLAND AVE AND 841 TILDEN OAKS TRAIL, ON THE NORTHWEST, NORTHEAST, AND SOUTHWEST CORNERS OF E OAKLAND AVE AND TILDEN OAKS TRAIL, FROM LOW DENSITY RESIDENTIAL TO RESIDENTIAL NEIGHBORHOOD COMMERCIAL; PROVIDING FOR SEVERABILITY; PROVIDING FOR AN EFFECTIVE DATE.
Copies of the proposed ordinance(s) (which includes the legal description in metes and bounds of the proposed site) may be inspected by the public between the hours of 8:00 a.m. and 5:00 p.m. Monday through Friday of each week, except for legal holidays, at the Planning & Zoning Division in City Hall, 300 West Plant Street, Winter Garden, Florida. For more information, please call Kelly Carson at 656-4111 ext. 2312.
Interested parties may appear at the meetings and be heard with respect to the proposed ordinance(s). Written comments will be accepted before or at the public hearings. Persons wishing to appeal any decision made by the Planning and Zoning Board at such hearing will need a record of the proceedings and for such purpose you may need to ensure that a verbatim record of the proceedings is made, which includes the testimony and evidence upon which the appeal is based. The City does not provide this verbatim record. Persons with disabilities needing special accommodations to participate in this public hearing should contact the City Clerk's Office at (407) 656-4111 at least 48 hours prior to the meeting. Monday through Friday of each week, except for legal holidays, at the Planning & Zoning Division in City Hall, 300 West Plant Street, Winter Garden, Florida.

NOTICE OF PUBLIC HEARING CITY OF WINTER GARDEN, FLORIDA Pursuant to the Florida Statutes, notice is hereby given that the City of Winter Garden City Commission will, on October 8, 2020 at 6:30 p.m. or as soon after as possible, hold a public hearing in the City Commission Chambers located at 300 West Plant Street, Winter Garden, Florida in order to consider the adoption of the following ordinance(s):
ORDINANCE 20-48

AN ORDINANCE OF THE CITY COMMISSION OF THE CITY OF WINTER GARDEN, FLORIDA VACATING A PORTION OF THE PLAT DEDICATED DRAINAGE AND UTILITY EASEMENT OVER LOT 16 OF WESTFIELD LAKES, ACCORDING TO THE PLAT THEREOF, AS RECORDED IN PLAT BOOK 36, PAGE 35, OF THE PUBLIC RECORDS OF ORANGE COUNTY, FLORIDA (LOCATED AT 427 ENGLISH LAKE DRIVE, WINTER GARDEN, FLORIDA) OWNED BY TREVOR J LARSEN AND MADIE L LARSEN, AS MORE PARTICULARLY DESCRIBED HEREIN; PROVIDING FOR AN EFFECTIVE DATE AND RECORDING.
Copies of the proposed ordinance(s) (which includes the legal description in metes and bounds of the proposed site) may be inspected by the public between the hours of 8:00 a.m. and 5:00 p.m. Monday through Friday of each week, except for legal holidays, at the Planning & Zoning Division in City Hall, 300 West Plant Street, Winter Garden, Florida. For more information, please call Kelly Carson at 656-4111 ext. 2312.
Interested parties may appear at the meetings and be heard with respect to the proposed ordinance(s). Written comments will be accepted before or at the public hearings. Persons wishing to appeal any decision made by the Planning and Zoning Board at such hearing will need a record of the proceedings and for such purpose you may need to ensure that a verbatim record of the proceedings is made, which includes the testimony and evidence upon which the appeal is based. The City does not provide this verbatim record. Persons with disabilities needing special accommodations to participate in this public hearing should contact the City Clerk's Office at (407) 656-4111 at least 48 hours prior to the meeting. Monday through Friday of each week, except for legal holidays, at the Planning & Zoning Division in City Hall, 300 West Plant Street, Winter Garden, Florida.

FIRST INSERTION

NOTICE OF PUBLIC SALE: The Car Store of West Orange gives Notice of Foreclosure of Lien and intent to sell these vehicles on 10/09/2020, 7:00 am at 12811 W Colonial Dr Winter Garden, FL 34787- 4119, pursuant to subsection 713.78 of the Florida Statutes. The Car Store of West Orange reserves the right to accept or reject any and/or all bids.
56161/192247 TRAILER
4CDR6ER23P2302645
1993 AMBASSADOR
1G8ZK827XTZ266176 1996 Saturn
1FMZU62E4Z2B60786 2002 Ford
1B3EL36X33N546058 2003 Dodge
2TKR32E24C311420 2004 Toyota
1FMZU62K34UB28126 2004 Ford
1FMZU62K94UA95150 2004 Ford
5GZCZ53445S860721 2005 Saturn
1G1ND52F15M169882 2005 Chevrolet
1N4AL1D55C950725 2005 Nissan
1G8AZ55FX7Z105083 2007 Saturn
1HGCM56707 A047196 2007 Honda
1GAHG39K681102843 2008 Chevrolet
1HGCS21878A001600 2008 Honda
3HSCUAPR9BN185694
2011 International
KNBJP3A53G7323164 2016 Kia
JTEBU5JR9G5376627 2016 Toyota
2T1BURHE0JC982539 2018 Toyota
September 24, 2020 20-03680W

FIRST INSERTION

Notice Under Fictitious Name Law According to Florida Statute Number 865.09
NOTICE IS HEREBY GIVEN that the undersigned, desiring to engage in business under the Fictitious Name of Prairie Lily Longarm Quilting located at 13861 Old Dock Road in the City of Orlando, Orange County, FL 32828 intends to register the said name with the Division of Corporations of the Florida Department of State, Tallahassee, Florida. Dated this 21st day of September, 2020.
Sandra M Scharch
September 24, 2020 20-03721W

FIRST INSERTION

FICTITIOUS NAME NOTICE Notice is hereby given that MELISHA DIANNA BATTLE, OWNER, desiring to engage in business under the fictitious name of \$5 BLING BOUTIQUE located at 2039 ORANGE CENTER BLVD #12103, ORLANDO, FLORIDA 32805 intends to register the said name in ORANGE county with the Division of Corporations, Florida Department of State, pursuant to section 865.09 of the Florida Statutes.
September 24, 2020 20-03689W

FIRST INSERTION

NOTICE OF PUBLIC HEARING CITY OF WINTER GARDEN, FLORIDA Pursuant to the Florida Statutes, notice is hereby given that the City of Winter Garden Planning and Zoning Board will, on October 5, 2020 at 6:30 p.m. or as soon after as possible, hold a public hearing in the City Commission Chambers located at 300 West Plant Street, Winter Garden, Florida in order to consider the adoption of the following ordinance(s):
ORDINANCE 20-37

AN ORDINANCE OF THE CITY OF WINTER GARDEN, FLORIDA, REZONING APPROXIMATELY 15.83 +/- ACRES OF CERTAIN REAL PROPERTY GENERALLY LOCATED ON WEST PLANT STREET, WEST OF LAKEVIEW ROAD AND SOUTH OF TILDENVILLE SCHOOL ROAD, FROM R-2 (RESIDENTIAL DISTRICT) TO PUD (PLANNED UNIT DEVELOPMENT); PROVIDING FOR CERTAIN PUD REQUIREMENTS AND DESCRIBING THE DEVELOPMENT AS THE A FOUND LIFE PUD; PROVIDING FOR NON-SEVERABILITY; PROVIDING FOR AN EFFECTIVE DATE.

You can attend in person or to participate in the Planning & Zoning Board's virtual public hearing, please click on the link to register online at: <http://www.cwgd.com/agendacenter>

Following the Planning & Zoning Board meeting, the City Commission of the City of Winter Garden will hold a public hearing in the City Commission Chambers located at 300 W. Plant Street, Winter Garden, FL on October 8, 2020 at 6:30 p.m., or as soon after as possible, to also consider the adoption of the ordinance(s).

You can attend in person or to participate in the City Commission's virtual public hearing, please click on the link to register online at: <http://www.cwgd.com/agendacenter>

Please visit the aforementioned website(s) in the days prior to the scheduled public hearings for more information about the public hearings, including any potential changes to the meeting location.

Copies of the proposed ordinance(s) (which includes the legal description in metes and bounds of the proposed site) may be inspected by the public between the hours of 8:00 a.m. and 5:00 p.m. Monday through Friday of each week, except for legal holidays, at the Planning & Zoning Division in City Hall, 300 West Plant Street, Winter Garden, Florida. For more information, please call Shane Friedman at 656-4111 ext. 2026.

Interested parties may appear at the meetings and be heard with respect to the proposed ordinance(s). Written comments will be accepted before or at the public hearings. Persons wishing to appeal any decision made by the Planning and Zoning Board at such hearing will need a record of the proceedings and for such purpose you may need to ensure that a verbatim record of the proceedings is made, which includes the testimony and evidence upon which the appeal is based. The City does not provide this verbatim record. Persons with disabilities needing special accommodations to participate in this public hearing should contact the City Clerk's Office at (407) 656-4111 at least 48 hours prior to the meeting. Monday through Friday of each week, except for legal holidays, at the Planning & Zoning Division in City Hall, 300 West Plant Street, Winter Garden, Florida.

LOCATION MAP

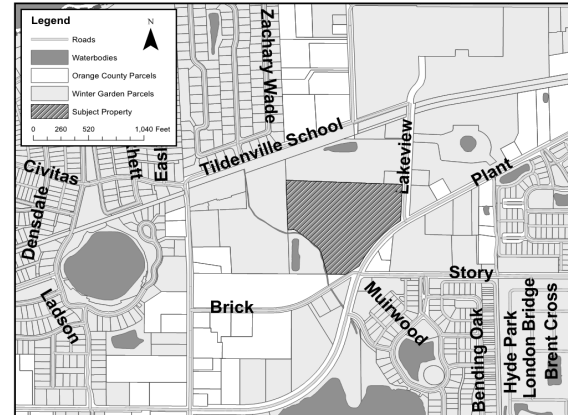

September 24, 2020

20-03725W

FIRST INSERTION

NOTICE OF PUBLIC HEARING CITY OF WINTER GARDEN, FLORIDA Pursuant to the Florida Statutes, notice is hereby given that the City of Winter Garden City Commission will, on October 8, 2020 at 6:30 p.m. or as soon after as possible, hold a public hearing in the City Commission Chambers located at 300 West Plant Street, Winter Garden, Florida in order to consider the adoption of the following ordinance(s):
ORDINANCE 20-48

AN ORDINANCE OF THE CITY COMMISSION OF THE CITY OF WINTER GARDEN, FLORIDA VACATING A PORTION OF THE PLAT DEDICATED DRAINAGE AND UTILITY EASEMENT OVER LOT 16 OF WESTFIELD LAKES, ACCORDING TO THE PLAT THEREOF, AS RECORDED IN PLAT BOOK 36, PAGE 35, OF THE PUBLIC RECORDS OF ORANGE COUNTY, FLORIDA (LOCATED AT 427 ENGLISH LAKE DRIVE, WINTER GARDEN, FLORIDA) OWNED BY TREVOR J LARSEN AND MADIE L LARSEN, AS MORE PARTICULARLY DESCRIBED HEREIN; PROVIDING FOR AN EFFECTIVE DATE AND RECORDING.
Copies of the proposed ordinance(s) (which includes the legal description in metes and bounds of the proposed site) may be inspected by the public between the hours of 8:00 a.m. and 5:00 p.m. Monday through Friday of each week, except for legal holidays, at the Planning & Zoning Division in City Hall, 300 West Plant Street, Winter Garden, Florida. For more information, please call Kelly Carson at 656-4111 ext. 2312.
Interested parties may appear at the meetings and be heard with respect to the proposed ordinance(s). Written comments will be accepted before or at the public hearings. Persons wishing to appeal any decision made by the Planning and Zoning Board at such hearing will need a record of the proceedings and for such purpose you may need to ensure that a verbatim record of the proceedings is made, which includes the testimony and evidence upon which the appeal is based. The City does not provide this verbatim record. Persons with disabilities needing special accommodations to participate in this public hearing should contact the City Clerk's Office at (407) 656-4111 at least 48 hours prior to the meeting. Monday through Friday of each week, except for legal holidays, at the Planning & Zoning Division in City Hall, 300 West Plant Street, Winter Garden, Florida.

LOCATION MAP

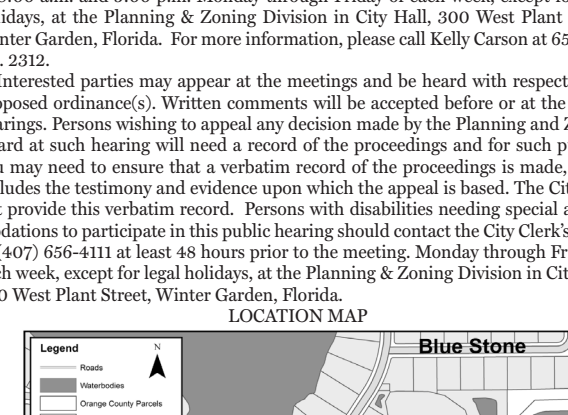

September 24, 2020

20-03681W

ORANGE COUNTY

FIRST INSERTION

NOTICE OF PUBLIC HEARING CITY OF WINTER GARDEN, FLORIDA

Pursuant to the Florida Statutes, notice is hereby given that the City of Winter Garden City Commission will, on October 8, 2020 at 6:30 p.m. or as soon after as possible, hold a public hearing in the City Commission Chambers located at 300 West Plant Street, Winter Garden, Florida in order to consider the adoption of the following ordinance(s):

ORDINANCE 20-39

AN ORDINANCE OF THE CITY OF WINTER GARDEN, FLORIDA PROVIDING FOR THE ANNEXATION OF CERTAIN ADDITIONAL LANDS GENERALLY DESCRIBED AS APPROXIMATELY 1.01 +/- ACRES LOCATED AT 465 PALM STREET, EAST OF 5TH STREET, WEST OF 9TH STREET, SOUTH OF MAGNOLIA STREET, AND NORTH OF PALM STREET INTO THE CITY OF WINTER GARDEN, FLORIDA; REDEFINING THE CITY BOUNDARIES TO GIVE THE CITY JURISDICTION OVER SAID PROPERTY; PROVIDING FOR SEVERABILITY; PROVIDING FOR AN EFFECTIVE DATE.

ORDINANCE 20-40

AN ORDINANCE OF THE CITY OF WINTER GARDEN, FLORIDA AMENDING THE FUTURE LAND USE MAP OF THE WINTER GARDEN COMPREHENSIVE PLAN BY CHANGING THE LAND USE DESIGNATION OF REAL PROPERTY GENERALLY DESCRIBED AS APPROXIMATELY 1.01 +/- ACRES LOCATED AT 465 PALM STREET, EAST OF 5TH STREET, WEST OF 9TH STREET, SOUTH OF MAGNOLIA STREET, AND NORTH OF PALM STREET FROM ORANGE COUNTY LOW DENSITY RESIDENTIAL TO CITY LOW DENSITY RESIDENTIAL; PROVIDING FOR SEVERABILITY; PROVIDING FOR AN EFFECTIVE DATE.

ORDINANCE 20-41

AN ORDINANCE OF THE CITY OF WINTER GARDEN, FLORIDA REZONING REAL PROPERTY GENERALLY DESCRIBED AS APPROXIMATELY 1.01 +/- ACRES LOCATED AT 465 PALM STREET, EAST OF 5TH STREET, WEST OF 9TH STREET, SOUTH OF MAGNOLIA STREET, AND NORTH OF PALM STREET FROM ORANGE COUNTY A-1 CITRUS RURAL DISTRICT TO CITY R-1 SINGLE-FAMILY RESIDENTIAL DISTRICT; PROVIDING FOR SEVERABILITY; PROVIDING FOR AN EFFECTIVE DATE.

Copies of the proposed ordinance(s) (which includes the legal description in metes and bounds of the proposed site) may be inspected by the public between the hours of 8:00 a.m. and 5:00 p.m. Monday through Friday of each week, except for legal holidays, at the Planning & Zoning Division in City Hall, 300 West Plant Street, Winter Garden, Florida. For more information, please call Kelly Carson at 656-4111 ext. 2312.

Interested parties may appear at the meetings and be heard with respect to the proposed ordinance(s). Written comments will be accepted before or at the public hearings. Persons wishing to appeal any decision made by the Planning and Zoning Board at such hearing will need a record of the proceedings and for such purpose you may need to ensure that a verbatim record of the proceedings is made, which includes the testimony and evidence upon which the appeal is based. The City does not provide this verbatim record. Persons with disabilities needing special accommodations to participate in this public hearing should contact the City Clerk's Office at (407) 656-4111 at least 48 hours prior to the meeting, Monday through Friday of each week, except for legal holidays, at the Planning & Zoning Division in City Hall, 300 West Plant Street, Winter Garden, Florida.

LOCATION MAP

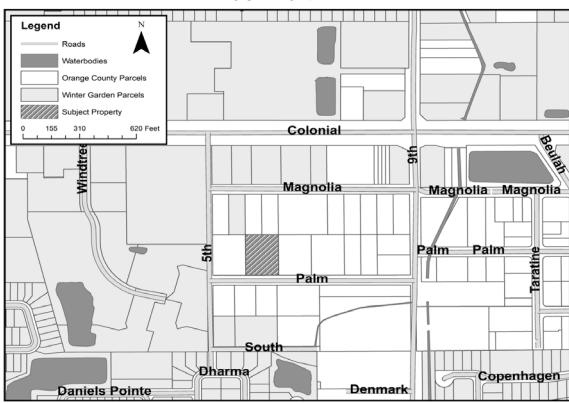

September 24, 2020 20-03683W

FIRST INSERTION

NOTICE OF PUBLIC HEARING CITY OF WINTER GARDEN, FLORIDA

Pursuant to the Florida Statutes, notice is hereby given that the City of Winter Garden Planning and Zoning Board will, on October 5, 2020 at 6:30 p.m. or as soon after as possible, hold a public hearing in the City Commission Chambers located at 300 West Plant Street, Winter Garden, Florida in order to consider the adoption of the following ordinance(s):

ORDINANCE 20-19

AN ORDINANCE OF THE CITY OF WINTER GARDEN, FLORIDA, REZONING CERTAIN REAL PROPERTY GENERALLY DESCRIBED AS APPROXIMATELY 1.07 +/- ACRES OF LAND GENERALLY LOCATED AT 199 S MAIN STREET AND 158 S WOODLAND STREET ON THE NORTHEAST CORNER OF S MAIN STREET AND E SMITH STREET, FROM C-1 (CENTRAL COMMERCIAL DISTRICT) TO PUD (PLANNED UNIT DEVELOPMENT); PROVIDING FOR CERTAIN PUD REQUIREMENTS AND DESCRIBING THE DEVELOPMENT AS THE SMITH STREET LUXURY STUDIOS PUD; PROVIDING FOR SEVERABILITY; PROVIDING FOR AN EFFECTIVE DATE.

Following the Planning & Zoning Board meeting, the City Commission of the City of Winter Garden will hold a public hearing in the City Commission Chambers located at 300 W. Plant Street, Winter Garden, FL on October 8, 2020 at 6:30 p.m., or as soon after as possible, to also consider the adoption of the ordinance(s).

Copies of the proposed ordinance(s) (which includes the legal description in metes and bounds of the proposed site) may be inspected by the public between the hours of 8:00 a.m. and 5:00 p.m. Monday through Friday of each week, except for legal holidays, at the Planning & Zoning Division in City Hall, 300 West Plant Street, Winter Garden, Florida. For more information, please call Kelly Carson at 407-656-4111 ext. 2312.

Interested parties may appear at the meetings and be heard with respect to the proposed ordinance(s). Written comments will be accepted before or at the public hearings. Persons wishing to appeal any decision made by the Planning and Zoning Board at such hearing will need a record of the proceedings and for such purpose you may need to ensure that a verbatim record of the proceedings is made, which includes the testimony and evidence upon which the appeal is based. The City does not provide this verbatim record. Persons with disabilities needing special accommodations to participate in this public hearing should contact the City Clerk's Office at (407) 656-4111 at least 48 hours prior to the meeting, Monday through Friday of each week, except for legal holidays, at the Planning & Zoning Division in City Hall, 300 West Plant Street, Winter Garden, Florida.

LOCATION MAP

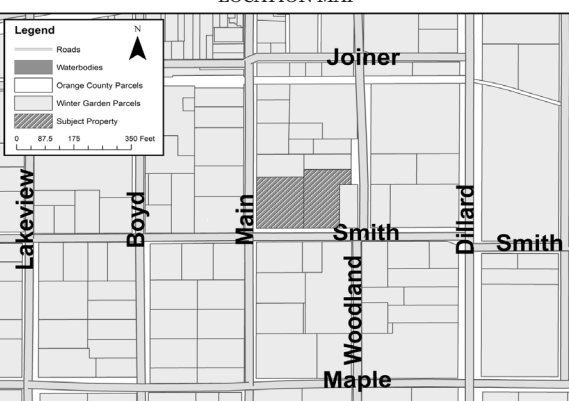

September 24, 2020 20-03684W

FIRST INSERTION

AT&T Mobility, LLC is proposing to construct a 34-foot overall height small cell telecommunications structure at 1403 West Church St., Orlando, Orange County, Florida (N28° 32' 25.2"; W81° 24' 4.9"). AT&T Mobility, LLC invites comments from any interested party on the impact the proposed undertaking may have on any districts, sites, buildings, structures, or objects significant in American history, archaeology, engineering, or culture that are listed or determined eligible for listing in the National Register of Historic Places under National Historic Preservation Act Section 106. Comments may be sent to Environmental Corporation of America, ATTN: Megan Gomez, 1375 Union Hill Industrial Court, Suite A, Alpharetta, GA 30004 or via email to publicnotice@eca-usa.com. Ms. Gomez can be reached at (770) 667-2040 x 405 during normal business hours. Comments must be received within 30 days of the date of this notice. W2637/MPG
September 24, 2020 20-03686W

FIRST INSERTION

FICTITIOUS NAME NOTICE
Notice is hereby given that KATHLYN CHELSEA DAVIS, OWNER, desiring to engage in business under the fictitious name of REVIVE COALITION located at 315 N. WYMORE RD, WINTER PARK, FLORIDA 32789 intends to register the said name in ORANGE county with the Division of Corporations, Florida Department of State, pursuant to section 865.09 of the Florida Statutes.
September 24, 2020 20-03701W

FIRST INSERTION

FICTITIOUS NAME NOTICE
Notice is hereby given that BCP MEDIA, INC., OWNER, desiring to engage in business under the fictitious name of PROOFREAD ANYWHERE located at 1810 BARKER DR, WINTER PARK, FLORIDA 32789 intends to register the said name in ORANGE county with the Division of Corporations, Florida Department of State, pursuant to section 865.09 of the Florida Statutes.
September 24, 2020 20-03705W

FIRST INSERTION

FICTITIOUS NAME NOTICE
Notice is hereby given that SAL CECERE, OWNER, desiring to engage in business under the fictitious name of X-FACTOR BOWLING SUPPLY located at 13748 AMELIA POND DR, WINDERMERE, FLORIDA 34786 intends to register the said name in ORANGE county with the Division of Corporations, Florida Department of State, pursuant to section 865.09 of the Florida Statutes.
September 24, 2020 20-03702W

FIRST INSERTION

FICTITIOUS NAME NOTICE
Notice is hereby given that MELISHA DIANNA BATTLE, OWNER, desiring to engage in business under the fictitious name of BLING BOUTIQUE located at 2039 ORANGE CENTER BLVD #12103, ORLANDO, FLORIDA 32805 intends to register the said name in ORANGE county with the Division of Corporations, Florida Department of State, pursuant to section 865.09 of the Florida Statutes.
September 24, 2020 20-03708W

FIRST INSERTION

FICTITIOUS NAME NOTICE
Notice is hereby given that ATLANTIC LIFE & HEALTH ADVISORS LLC, OWNER, desiring to engage in business under the fictitious name of ATLANTIC INSURANCE CONSULTANTS located at 243 W LAKE FAITH DR, MAITLAND, FLORIDA 32751 intends to register the said name in ORANGE county with the Division of Corporations, Florida Department of State, pursuant to section 865.09 of the Florida Statutes.
September 24, 2020 20-03703W

FIRST INSERTION

AT&T Mobility, LLC is proposing to construct a 42-foot overall height small cell telecommunications structure at 13000 Breaking Dawn Drive, Orlando, Orange County, Florida (N28° 21' 52.5"; W81° 21' 59.5"). AT&T Mobility, LLC invites comments from any interested party on the impact the proposed undertaking may have on any districts, sites, buildings, structures, or objects significant in American history, archaeology, engineering, or culture that are listed or determined eligible for listing in the National Register of Historic Places under National Historic Preservation Act Section 106. Comments may be sent to Environmental Corporation of America, ATTN: Megan Gomez, 1375 Union Hill Industrial Court, Suite A, Alpharetta, GA 30004 or via email to publicnotice@eca-usa.com. Ms. Gomez can be reached at (770) 667-2040 x 405 during normal business hours. Comments must be received within 30 days of the date of this notice. W2215/MPG
September 24, 2020 20-03722W

FIRST INSERTION

FICTITIOUS NAME NOTICE
Notice is hereby given that TYRONE KALIN BROWN, OWNER, desiring to engage in business under the fictitious name of TRUST YOURSELF located at 2211 MOSHER DR, ORLANDO, FLORIDA 32810 intends to register the said name in ORANGE county with the Division of Corporations, Florida Department of State, pursuant to section 865.09 of the Florida Statutes.
September 24, 2020 20-03695W

FIRST INSERTION

FICTITIOUS NAME NOTICE
Notice is hereby given that SHANKIYAH MARKISHA KING, OWNER, desiring to engage in business under the fictitious name of THE YARD located at 431 SOUTH DOLLINS AVENUE, ORLANDO, FLORIDA 32805 intends to register the said name in ORANGE county with the Division of Corporations, Florida Department of State, pursuant to section 865.09 of the Florida Statutes.
September 24, 2020 20-03692W

FIRST INSERTION

FICTITIOUS NAME NOTICE
Notice is hereby given that CAT ADJUSTERS GROUP, INC, OWNER, desiring to engage in business under the fictitious name of CAT ADJUSTERS located at 1317 EDGEWATER DR., SUITE 1091, ORLANDO, FLORIDA 32804 intends to register the said name in ORANGE county with the Division of Corporations, Florida Department of State, pursuant to section 865.09 of the Florida Statutes.
September 24, 2020 20-03697W

FIRST INSERTION

FICTITIOUS NAME NOTICE
Notice is hereby given that EVELYN KALERGY, OWNER, desiring to engage in business under the fictitious name of ACE E.E. CONSULTING located at 1627 FUREY DRIVE, ORLANDO, FLORIDA 32822 intends to register the said name in ORANGE county with the Division of Corporations, Florida Department of State, pursuant to section 865.09 of the Florida Statutes.
September 24, 2020 20-03714W

FIRST INSERTION

FICTITIOUS NAME NOTICE
Notice is hereby given that JUANITA M CARTER, OWNER, desiring to engage in business under the fictitious name of NEAT'S CANDY LAND & MORE located at 1857 TIGERWOOD CT, ORLANDO, FLORIDA 32818 intends to register the said name in ORANGE county with the Division of Corporations, Florida Department of State, pursuant to section 865.09 of the Florida Statutes.
September 24, 2020 20-03704W

FIRST INSERTION

FICTITIOUS NAME NOTICE
Notice is hereby given that WEST BUILDING SERVICES LLC, OWNER, desiring to engage in business under the fictitious name of RON WEST ROOFING LLC located at 10651 BUCK ROAD, ORLANDO, FLORIDA 32817 intends to register the said name in ORANGE county with the Division of Corporations, Florida Department of State, pursuant to section 865.09 of the Florida Statutes.
September 24, 2020 20-03709W

FIRST INSERTION

FICTITIOUS NAME NOTICE
Notice is hereby given that NORDEN LEACOX, PLLC, OWNER, desiring to engage in business under the fictitious name of NORDEN LEACOX ACCIDENT & INJURY LAW located at 801 N. MAGNOLIA AVE, STE. 309, ORLANDO, FLORIDA 32803 intends to register the said name in ORANGE county with the Division of Corporations, Florida Department of State, pursuant to section 865.09 of the Florida Statutes.
September 24, 2020 20-03711W

FIRST INSERTION

Notice is hereby given that on dates below these vehicles will be sold at public sale on the date listed below at 10AM for monies owed on vehicle repair and storage cost pursuant to Florida Statutes 713.585. Please note, parties claiming interest have right to a hearing prior to the date of sale with the Clerk of Courts as reflected in the notice. The owner has the right to recover possession of the vehicle without judicial proceedings as pursuant to Florida Statute 559.917. Any proceeds recovered from the sale of the vehicle over the amount of the lien will be deposited clerk of the court for disposition upon court order. "No Title Guaranteed, A Buyer Fee May Apply" start at 10AM 10/16/20 Factory Finish 1505 Pine Ave
10 CHEV 1GCDSCD99A8101370 \$3370.50
10/26/20 12 SION JTLZE4FE5C1147064 \$7755.40
September 24, 2020 20-03797W

FIRST INSERTION

FICTITIOUS NAME NOTICE
Notice is hereby given that HANNAH LE, OWNER, desiring to engage in business under the fictitious name of LILY NAILS located at 1708 WOOLCO WAY, ORLANDO, FLORIDA 32822 intends to register the said name in ORANGE county with the Division of Corporations, Florida Department of State, pursuant to section 865.09 of the Florida Statutes.
September 24, 2020 20-03696W

FIRST INSERTION

FICTITIOUS NAME NOTICE
Notice is hereby given that IVANHOE PLACE PROPCO, LLC, OWNER, desiring to engage in business under the fictitious name of THE YARD located at 101 SOUTH EOLA DR, STE 1205, ORLANDO, FLORIDA 32801 intends to register the said name in ORANGE county with the Division of Corporations, Florida Department of State, pursuant to section 865.09 of the Florida Statutes.
September 24, 2020 20-03693W

FIRST INSERTION

FICTITIOUS NAME NOTICE
Notice is hereby given that MICROBE DEFENSE SPECIALISTS LLC, OWNER, desiring to engage in business under the fictitious name of MDS-SHIELD located at 9226 BAY HILL BLVD., ORLANDO, FLORIDA 32819 intends to register the said name in ORANGE county with the Division of Corporations, Florida Department of State, pursuant to section 865.09 of the Florida Statutes.
September 24, 2020 20-03698W

FIRST INSERTION

FICTITIOUS NAME NOTICE
Notice is hereby given that BENJAMIN KARLSON, OWNER, desiring to engage in business under the fictitious name of TYE-EX located at 2933 BUSHMEAD CT, COCOE, FLORIDA 34761 intends to register the said name in ORANGE county with the Division of Corporations, Florida Department of State, pursuant to section 865.09 of the Florida Statutes.
September 24, 2020 20-03719W

FIRST INSERTION

FICTITIOUS NAME NOTICE
Notice is hereby given that FRANK FARRELL DIPASQUALE, OWNER, desiring to engage in business under the fictitious name of FUNHOUSE ART STUDIOS located at 7778 FORT MCHENRY CT, ORLANDO, FLORIDA 32822 intends to register the said name in ORANGE county with the Division of Corporations, Florida Department of State, pursuant to section 865.09 of the Florida Statutes.
September 24, 2020 20-03706W

FIRST INSERTION

FICTITIOUS NAME NOTICE
Notice is hereby given that MONIQUE EMMERICK-GILCHRIST, OWNER, desiring to engage in business under the fictitious name of MEG SALON BOUTIQUE located at 101 GATLIN AVE, #121, ORLANDO, FLORIDA 32806 intends to register the said name in ORANGE county with the Division of Corporations, Florida Department of State, pursuant to section 865.09 of the Florida Statutes.
September 24, 2020 20-03710W

FIRST INSERTION

FICTITIOUS NAME NOTICE
Notice is hereby given that ELLIOT RIVERA GUADARRAMA, OWNER, desiring to engage in business under the fictitious name of E.R. CLEANING SERVICES located at 5250 N. ORANGE BLOSSOM TRAIL, APT 106, ORLANDO, FLORIDA 32810 intends to register the said name in ORANGE county with the Division of Corporations, Florida Department of State, pursuant to section 865.09 of the Florida Statutes.
September 24, 2020 20-03713W

FIRST INSERTION

FICTITIOUS NAME NOTICE
Notice is hereby given that LINETTE ALICEA, OWNER, desiring to engage in business under the fictitious name of STYLE ME CRAZY located at 3412 ALOMA AVE, WINTER PARK, FLORIDA 32792 intends to register the said name in ORANGE county with the Division of Corporations, Florida Department of State, pursuant to section 865.09 of the Florida Statutes.
September 24, 2020 20-03803W

FIRST INSERTION

FICTITIOUS NAME NOTICE
Notice is hereby given that CHOOSE KOS, LLC, OWNER, desiring to engage in business under the fictitious name of KOS located at 1411 MAGNOLIA AVE, WINTER PARK, FLORIDA 32789 intends to register the said name in ORANGE county with the Division of Corporations, Florida Department of State, pursuant to section 865.09 of the Florida Statutes.
September 24, 2020 20-03699W

FIRST INSERTION

FICTITIOUS NAME NOTICE
Notice is hereby given that MATTHEW RICHMOND WALDECK, OWNER, desiring to engage in business under the fictitious name of BEST DAY MEDIA located at 10317 LICORICE WAY, ORLANDO, FLORIDA 32821 intends to register the said name in ORANGE county with the Division of Corporations, Florida Department of State, pursuant to section 865.09 of the Florida Statutes.
September 24, 2020 20-03694W

FIRST INSERTION

FICTITIOUS NAME NOTICE
Notice is hereby given that ARIANA DRESNER, OWNER, desiring to engage in business under the fictitious name of LUROSE BOUTIQUE located at 7818 CROSSWATER TRAIL, APT 4307, WINDERMERE, FLORIDA 34786 intends to register the said name in ORANGE county with the Division of Corporations, Florida Department of State, pursuant to section 865.09 of the Florida Statutes.
September 24, 2020 20-03700W

FIRST INSERTION

FICTITIOUS NAME NOTICE
Notice is hereby given that CARLOS SANTOS, OWNER, desiring to engage in business under the fictitious name of COCONUT GRILL located at 21501 JINGLE RD, CHRISTMAS, FLORIDA 32709 intends to register the said name in ORANGE county with the Division of Corporations, Florida Department of State, pursuant to section 865.09 of the Florida Statutes.
September 24, 2020 20-03779W

FIRST INSERTION

FICTITIOUS NAME NOTICE
Notice is hereby given that ALYSSIA S MCDONALD, OWNER, desiring to engage in business under the fictitious name of FITTED BY ALY located at 7843 PINE CROSSINGS CIR, ORLANDO, FLORIDA 32807 intends to register the said name in ORANGE county with the Division of Corporations, Florida Department of State, pursuant to section 865.09 of the Florida Statutes.
September 24, 2020 20-03707W

FIRST INSERTION

FICTITIOUS NAME NOTICE
Notice is hereby given that LOVE OF THE MAGIC VACATIONS, LLC, OWNER, desiring to engage in business under the fictitious name of LOVE OF TRAVEL VACATIONS located at 2046 SOLAR DRIVE, WINTER GARDEN, FLORIDA 34787 intends to register the said name in ORANGE county with the Division of Corporations, Florida Department of State, pursuant to section 865.09 of the Florida Statutes.
September 24, 2020 20-03712W

FIRST INSERTION

FICTITIOUS NAME NOTICE
Notice is hereby given that PANORAMA MORTGAGE GROUP, LLC, OWNER, desiring to engage in business under the fictitious name of PANORAMA MORTGAGE ADVISORS located at 350 S RAMPART BLVD, SUITE 310, LAS VEGAS, NEVADA 89145 intends to register the said name in ORANGE county with the Division of Corporations, Florida Department of State, pursuant to section 865.09 of the Florida Statutes.
September 24, 2020 20-03691W

FIRST INSERTION

NOTICE OF PUBLIC SALE
SLY'S TOWING & RECOVERY gives Notice of Foreclosure of Lien and intent to sale the following vehicles, pursuant to the FL Statutes 713.78 on 10/08/2020 at 10:00 a.m. at 119 5th Street, Winter Garden, FL 34787. SLY'S TOWING & RECOVERY reserves the right to accept or reject any and/or all bids. 4M2YU56166KJ15343 2006 Mercury KNMAT2MT3KP549262 2019 Nissan
September 24, 2020 20-03805W

HOW TO PUBLISH YOUR LEGAL NOTICE
IN THE BUSINESS OBSERVER

CALL 941-906-9386
and select the appropriate County name from the menu option or e-mail legal@businessobserverfl.com

Business Observer

ORANGE COUNTY

FIRST INSERTION
FICTITIOUS NAME NOTICE
 Notice is hereby given that ANNETTE ZAIDA QUINONES, OWNER, desiring to engage in business under the fictitious name of THE ART OF ZAIDA located at 182 DAHLIA VILLAGE CIRCLE, ORLANDO, FLORIDA 32807 intends to register the said name in ORANGE county with the Division of Corporations, Florida Department of State, pursuant to section 865.09 of the Florida Statutes.
 September 24, 2020 20-03715W

FIRST INSERTION
FICTITIOUS NAME NOTICE
 Notice is hereby given that OASIS FOR OPTIMAL HEALTH, LLC, OWNER, desiring to engage in business under the fictitious name of SIMPLICITY BY DR. E located at 4125 HUNTERS PARK LN STE 117, ORLANDO, FLORIDA 32837 intends to register the said name in ORANGE county with the Division of Corporations, Florida Department of State, pursuant to section 865.09 of the Florida Statutes.
 September 24, 2020 20-03716W

FIRST INSERTION
FICTITIOUS NAME NOTICE
 Notice is hereby given that ERNEST HARTFIELD, OWNER, desiring to engage in business under the fictitious name of HARTFIELD COMPLETE SERVICES located at 11954 NARCOOSEE RD, #2, #185, ORLANDO, FLORIDA 32832 intends to register the said name in ORANGE county with the Division of Corporations, Florida Department of State, pursuant to section 865.09 of the Florida Statutes.
 September 24, 2020 20-03717W

FIRST INSERTION
FICTITIOUS NAME NOTICE
 Notice is hereby given that CLAUDINE SWEET TREATS INC., OWNER, desiring to engage in business under the fictitious name of SATCHER PHOTOGRAPHY located at 20837 YAM ST, ORLANDO, FLORIDA 32833 intends to register the said name in ORANGE county with the Division of Corporations, Florida Department of State, pursuant to section 865.09 of the Florida Statutes.
 September 24, 2020 20-03720W

FIRST INSERTION
NOTICE OF PUBLIC SALE
 TOW PROS OF ORLANDO gives Notice of Foreclosure of Lien and intent to sell these vehicles on 10/16/2020, 9:00 a.m. at 11424 SPACE BLVD., ORLANDO, FL 32837, pursuant to subsection 713.78 of the Florida Statutes. TOW PROS OF ORLANDO reserves the right to accept or reject any and/or all bids. 2005 FORD 1FMZU67K25UB02689 2012 FORD 3FADP4BJ6CM128177
LOCATION:
 11424 SPACE BLVD.
 ORLANDO, FL 32837
 Phone: 321-287-1094
 September 24, 2020 20-03778W

FIRST INSERTION
NOTICE OF PUBLIC SALE
 SLY'S TOWING & RECOVERY gives Notice of Foreclosure of Lien and intent to sale the following vehicles, pursuant to the FL Statutes 713.78 on 10/15/2020 at 10:00 a.m. at 119 5th Street, Winter Garden, FL 34787. SLY'S TOWING & RECOVERY reserves the right to accept or reject any and/or all bids. 1FA6POH78E5383483 2014 Ford 1GKS1CE09CR221973 2012 GMC 1J8GS48K27C544779 2007 Jeep 1N4AA6AP4JC786666 2018 Nissan 5N1DR2BN3LC582007 2020 Nissan
 September 24, 2020 20-03806W

FIRST INSERTION
FICTITIOUS NAME NOTICE
 Notice is hereby given that RAW LYFE ENTERPRISES, LLC, OWNER, desiring to engage in business under the fictitious name of MONARCH SUPREME BEARD located at 8011 COUNTRY RUN PARKWAY, ORLANDO, FLORIDA 32818 intends to register the said name in ORANGE county with the Division of Corporations, Florida Department of State, pursuant to section 865.09 of the Florida Statutes.
 September 24, 2020 20-03718W

FIRST INSERTION
NOTICE OF PUBLIC SALE
 Notice is hereby given that on 10/9/2020 at 10:30 a.m., the following property will be sold at public auction pursuant to F.S. 715.109: 1969 CHAM mobile home bearing vehicle identification number 0409685252 and all personal items located inside the mobile home. Last Tenant: Jerald Feldt. Sale to be held at: The Hills, 1100 South Roger Williams Road, Apopka, Florida 32703, 407-886-8787.
 Sep. 24; Oct. 1, 2020 20-03781W

FIRST INSERTION
NOTICE OF PUBLIC SALE
 Notice is hereby given that on 10/9/2020 at 10:30 a.m., the following property will be sold at public auction pursuant to F.S. 715.109: 1975 CLAS mobile home bearing vehicle identification number 1851 and all personal items located inside the mobile home. Last Tenant: Duane Pearce a/k/a Duane Leslie Pearce. Sale to be held at: The Hills, 1100 South Roger Williams Road, Apopka, Florida 32703, 407-886-8787.
 Sep. 24; Oct. 1, 2020 20-03782W

FIRST INSERTION
FICTITIOUS NAME NOTICE
 Notice is hereby given that ANDREW LEE SIMS, OWNER, desiring to engage in business under the fictitious name of FOURCORNERZGLOBALHOUSE located at 1729 FLORES CT, ORLANDO, FLORIDA 32811 intends to register the said name in ORANGE county with the Division of Corporations, Florida Department of State, pursuant to section 865.09 of the Florida Statutes.
 September 24, 2020 20-03799W

FIRST INSERTION
NOTICE OF PUBLIC HEARING
CITY OF WINTER GARDEN, FLORIDA
 Pursuant to the Florida Statutes, notice is hereby given that the City of Winter Garden Planning and Zoning Board will, on October 5, 2020 at 6:30 p.m. or as soon after as possible, hold a public hearing in the City Commission Chambers located at 300 West Plant Street, Winter Garden, Florida in order to consider the adoption of the following ordinance(s):

ORDINANCE 20-52
AN ORDINANCE OF THE CITY OF WINTER GARDEN, FLORIDA REZONING APPROXIMATELY 0.17 +/- ACRES LOCATED AT 21 WEST SMITH STREET ON THE NORTHEAST CORNER OF WEST SMITH STREET AND SOUTH BOYD STREET FROM CITY R-2 RESIDENTIAL DISTRICT TO CITY C-1 CENTRAL COMMERCIAL DISTRICT; PROVIDING FOR SEVERABILITY; PROVIDING FOR AN EFFECTIVE DATE

You can attend in person or to participate in the Planning & Zoning Board's virtual public hearing, please click on the link to register online at:
<http://www.cwgd.com/agendacenter>

You can attend in person or to participate in the Planning & Zoning Board's virtual public hearing, please click on the link to register online at: <http://www.cwgd.com/agendacenter>

Following the Planning & Zoning Board meeting, the City Commission of the City of Winter Garden will hold a public hearing in the City Commission Chambers located at 300 W. Plant Street, Winter Garden, FL on October 8, 2020 at 6:30 p.m., or as soon after as possible, to also consider the adoption of the ordinance(s).

You can attend in person or to participate in the City Commission's virtual public hearing, please click on the link to register online at:
<http://www.cwgd.com/agendacenter>

Please visit the aforementioned website(s) in the days prior to the scheduled public hearings for more information about the public hearings, including any potential changes to the meeting location.

Copies of the proposed ordinance(s) (which includes the legal description in metes and bounds of the proposed site) may be inspected by the public between the hours of 8:00 a.m. and 5:00 p.m. Monday through Friday of each week, except for legal holidays, at the Planning & Zoning Division in City Hall, 300 West Plant Street, Winter Garden, Florida. For more information, please call Shane Friedman at 656-4111 ext. 2026.

Interested parties may appear at the meetings and be heard with respect to the proposed ordinance(s). Written comments will be accepted before or at the public hearings. Persons wishing to appeal any decision made by the Planning and Zoning Board at such hearing will need a record of the proceedings and for such purpose you may need to ensure that a verbatim record of the proceedings is made, which includes the testimony and evidence upon which the appeal is based. The City does not provide this verbatim record. Persons with disabilities needing special accommodations to participate in this public hearing should contact the City Clerk's Office at (407) 656-4111 at least 48 hours prior to the meeting. Monday through Friday of each week, except for legal holidays, at the Planning & Zoning Division in City Hall, 300 West Plant Street, Winter Garden, Florida.

LOCATION MAP

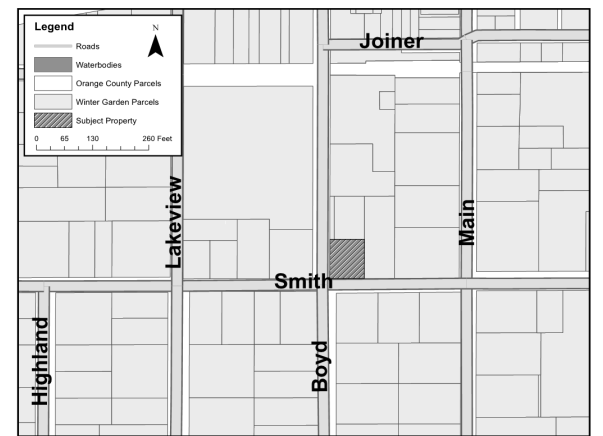

September 24, 2020 20-03727W

FIRST INSERTION
NOTICE OF PUBLIC HEARING
 You will please take notice that on Friday, October 2, 2020 at 8:30 am, HWO Inc. dba Foundation for a Healthier West Orange will hold a virtual district meeting via teleconference Meeting ID: 897 1236 3852; Dial-in: 1-253-215-8782. (To be held by telephone conference in light of the COVID-19 state of emergency and Executive Order 20-69 issued on March 20, 2020 by Governor DeSantis providing that entities subject to Sunshine may utilize communication media technology.) At that time, they will consider such business as may properly come before them. West Orange Healthcare District Board of Trustees
 September 24, 2020 20-03724W

FIRST INSERTION
Notice Under Fictitious Name Law
 Pursuant to Section 865.09, Florida Statutes
NOTICE IS HEREBY GIVEN that the undersigned, desiring to engage in business under fictitious name of Coda located at 3737 E. Broadway, in the County of Orange, in the City of Long Beach, CA 90803, intends to register the said name with the Division of Corporations of the Florida Department of State, Tallahassee, Florida. Dated at Orange, Florida, this 18th day of September, 2020.
 RK Coda Master Tentant LLC
 September 24, 2020 20-03798W

FIRST INSERTION
FICTITIOUS NAME NOTICE
 Notice is hereby given that SOUTH HI-AWASSEE VILLAGE, LTD., OWNER, desiring to engage in business under the fictitious name of SOUTH HI-AWASSEE VILLAGE located at 708 S GAY ST, STE. 200, KNOXVILLE, TENNESSEE 37902 intends to register the said name in ORANGE county with the Division of Corporations, Florida Department of State, pursuant to section 865.09 of the Florida Statutes.
 September 24, 2020 20-03801W

FIRST INSERTION
FICTITIOUS NAME NOTICE
 Notice is hereby given that KISER & TRUONG LLC, OWNER, desiring to engage in business under the fictitious name of MOE'S SOUTHWEST GRILL located at 4192 CONROY ROAD, STE 115, ORLANDO, FLORIDA 32839 intends to register the said name in ORANGE county with the Division of Corporations, Florida Department of State, pursuant to section 865.09 of the Florida Statutes.
 September 24, 2020 20-03800W

FIRST INSERTION
FICTITIOUS NAME NOTICE
 Notice is hereby given that JUDITH MENDERS, OWNER, desiring to engage in business under the fictitious name of U-R DIVINE HANDMADE CRAFT located at P.O. BOX 618762, ORLANDO, FLORIDA 32861 intends to register the said name in ORANGE county with the Division of Corporations, Florida Department of State, pursuant to section 865.09 of the Florida Statutes.
 September 24, 2020 20-03802W

FIRST INSERTION
FICTITIOUS NAME NOTICE
 Notice is hereby given that MADLINE DEMELIEN, OWNER, desiring to engage in business under the fictitious name of MADLINE DEMELIEN DBA DURACARE SUPPORT SERVICES located at 5461 LAKE MARGARET DRIVE, APT D, ORLANDO, FLORIDA 32812 intends to register the said name in ORANGE county with the Division of Corporations, Florida Department of State, pursuant to section 865.09 of the Florida Statutes.
 September 24, 2020 20-03780W

FIRST INSERTION
NOTICE OF PUBLIC HEARING
CITY OF WINTER GARDEN, FLORIDA
 Pursuant to the Florida Statutes, notice is hereby given that the City Commission of the City of Winter Garden will, on October 8, 2020 at 6:30 p.m. or as soon after as possible, hold a public hearing in the City Commission Chambers located at 300 West Plant Street, Winter Garden, Florida in order to consider the adoption of the following ordinance(s):

ORDINANCE 20-43
AN ORDINANCE OF THE CITY OF WINTER GARDEN, FLORIDA PROVIDING FOR THE ANNEXATION OF CERTAIN ADDITIONAL LANDS GENERALLY DESCRIBED AS APPROXIMATELY 0.27 +/- ACRES LOCATED AT 198 AND 176 NORTH WEST CROWN POINT ROAD, EAST OF HENNIS ROAD, WEST OF NORTH WEST CROWN POINT ROAD, NORTH OF PINELOCH INDUSTRIAL DRIVE, AND SOUTH OF RAILROAD AVENUE INTO THE CITY OF WINTER GARDEN, FLORIDA; REDEFINING THE CITY BOUNDARIES TO GIVE THE CITY JURISDICTION OVER SAID PROPERTY; PROVIDING FOR SEVERABILITY; PROVIDING FOR AN EFFECTIVE DATE.

ORDINANCE 20-44
AN ORDINANCE OF THE CITY OF WINTER GARDEN, FLORIDA AMENDING THE FUTURE LAND USE MAP OF THE WINTER GARDEN COMPREHENSIVE PLAN BY CHANGING THE LAND USE DESIGNATION OF REAL PROPERTY GENERALLY DESCRIBED AS APPROXIMATELY 0.27 +/- ACRES LOCATED AT 198 AND 176 NORTH WEST CROWN POINT ROAD, EAST OF HENNIS ROAD, WEST OF NORTH WEST CROWN POINT ROAD, NORTH OF PINELOCH INDUSTRIAL DRIVE, AND SOUTH OF RAILROAD AVENUE FROM ORANGE COUNTY LOW DENSITY RESIDENTIAL TO CITY COMMERCIAL; PROVIDING FOR SEVERABILITY; PROVIDING FOR AN EFFECTIVE DATE.

ORDINANCE 20-45
AN ORDINANCE OF THE CITY OF WINTER GARDEN, FLORIDA REZONING APPROXIMATELY 0.27 +/- ACRES LOCATED AT 198 AND 176 NORTH WEST CROWN POINT ROAD, EAST OF HENNIS ROAD, WEST OF NORTH WEST CROWN POINT ROAD, NORTH OF PINELOCH INDUSTRIAL DRIVE, AND SOUTH OF RAILROAD AVENUE FROM ORANGE COUNTY R-2 RESIDENTIAL DISTRICT TO CITY C-2 ARTERIAL COMMERCIAL DISTRICT; PROVIDING FOR SEVERABILITY; PROVIDING FOR AN EFFECTIVE DATE.

You can attend in person or to participate in the City Commission's virtual public hearing, please click on the link to register online at:
<http://www.cwgd.com/agendacenter>

Following the Planning & Zoning Board meeting, the City Commission of the City of Winter Garden will hold a public hearing in the City Commission Chambers located at 300 W. Plant Street, Winter Garden, FL on October 8, 2020 at 6:30 p.m., or as soon after as possible, to also consider the adoption of the ordinance(s).

You can attend in person or to participate in the City Commission's virtual public hearing, please click on the link to register online at:
<http://www.cwgd.com/agendacenter>

Please visit the aforementioned website(s) in the days prior to the scheduled public hearings for more information about the public hearings, including any potential changes to the meeting location.

Copies of the proposed ordinance(s) (which includes the legal description in metes and bounds of the proposed site) may be inspected by the public between the hours of 8:00 a.m. and 5:00 p.m. Monday through Friday of each week, except for legal holidays, at the Planning & Zoning Division in City Hall, 300 West Plant Street, Winter Garden, Florida. For more information, please call Shane Friedman at 656-4111 ext. 2026.

Interested parties may appear at the meetings and be heard with respect to the proposed ordinance(s). Written comments will be accepted before or at the public hearings. Persons wishing to appeal any decision made by the Planning and Zoning Board at such hearing will need a record of the proceedings and for such purpose you may need to ensure that a verbatim record of the proceedings is made, which includes the testimony and evidence upon which the appeal is based. The City does not provide this verbatim record. Persons with disabilities needing special accommodations to participate in this public hearing should contact the City Clerk's Office at (407) 656-4111 at least 48 hours prior to the meeting. Monday through Friday of each week, except for legal holidays, at the Planning & Zoning Division in City Hall, 300 West Plant Street, Winter Garden, Florida.

LOCATION MAP

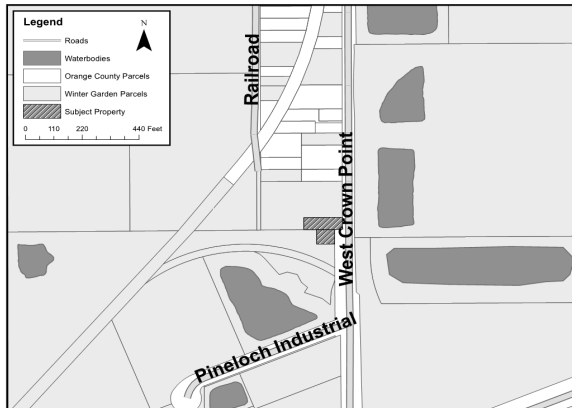

September 24, 2020 20-03726W

FIRST INSERTION
NOTICE OF PUBLIC HEARING
CITY OF WINTER GARDEN, FLORIDA
 Pursuant to the Florida Statutes, notice is hereby given that the City of Winter Garden Planning and Zoning Board will, on October 5, 2020 at 6:30 p.m. or as soon after as possible, hold a public hearing in the City Commission Chambers located at 300 West Plant Street, Winter Garden, Florida in order to consider the adoption of the following ordinance(s):

ORDINANCE 20-47
AN ORDINANCE OF THE CITY OF WINTER GARDEN, FLORIDA, REZONING CERTAIN REAL PROPERTY GENERALLY DESCRIBED AS APPROXIMATELY 5.83 +/- ACRES OF LAND GENERALLY LOCATED AT 855 & 955 SOUTH DILLARD STREET, EAST OF SOUTH DILLARD STREET, SOUTH OF EAST PALMETTO STREET, NORTH OF WEST COLONIAL DRIVE, AND WEST OF GRAND ROYAL CIRCLE; FROM C-2 (CENTRAL COMMERCIAL DISTRICT) AND FROM THE EXISTING PLANNED COMMERCIAL DEVELOPMENT (PCD) ADOPTED BY ORDINANCE 06-23, TO PCD (PLANNED COMMERCIAL DEVELOPMENT) AS SET FORTH IN THIS ORDINANCE; PROVIDING FOR CERTAIN PCD REQUIREMENTS AND DESCRIBING THE DEVELOPMENT AS THE CENTRAL PARC AT WINTER GARDEN PCD; REPEALING AND REPLACING ORDINANCE 06-23; AND PROVIDING FOR SEVERABILITY, CONFLICTS AND AN EFFECTIVE DATE.

Following the Planning & Zoning Board meeting, the City Commission of the City of Winter Garden will hold a public hearing in the City Commission Chambers located at 300 W. Plant Street, Winter Garden, FL on October 8, 2020 at 6:30 p.m., or as soon after as possible, to also consider the adoption of the ordinance(s).

Copies of the proposed ordinance(s) (which includes the legal description in metes and bounds of the proposed site) may be inspected by the public between the hours of 8:00 a.m. and 5:00 p.m. Monday through Friday of each week, except for legal holidays, at the Planning & Zoning Division in City Hall, 300 West Plant Street, Winter Garden, Florida. For more information, please call Kelly Carson at 407-656-4111 ext. 2312.

Interested parties may appear at the meetings and be heard with respect to the proposed ordinance(s). Written comments will be accepted before or at the public hearings. Persons wishing to appeal any decision made by the Planning and Zoning Board at such hearing will need a record of the proceedings and for such purpose you may need to ensure that a verbatim record of the proceedings is made, which includes the testimony and evidence upon which the appeal is based. The City does not provide this verbatim record. Persons with disabilities needing special accommodations to participate in this public hearing should contact the City Clerk's Office at (407) 656-4111 at least 48 hours prior to the meeting. Monday through Friday of each week, except for legal holidays, at the Planning & Zoning Division in City Hall, 300 West Plant Street, Winter Garden, Florida.

LOCATION MAP

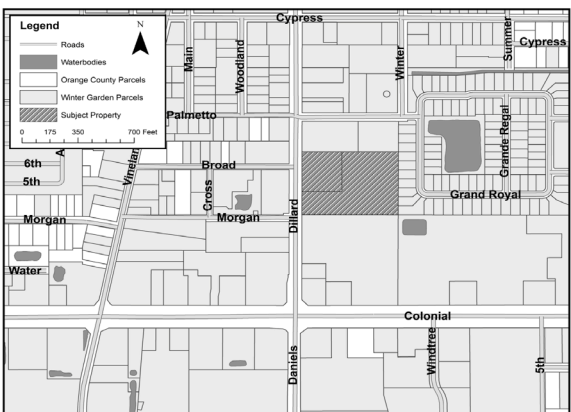

September 24, 2020 20-03685W

SUBSCRIBE TO THE BUSINESS OBSERVER
 Call: (941) 362-4848 or go to: www.businessobserverfl.com

STATEMENT OF OWNERSHIP, MANAGEMENT AND CIRCULATION, 1. Publication Title: West Orange Times. **2.** Publication No.: 687-120 **3.** Filing Date: 9/24/20. **4.** Issue Frequency: Weekly. **5.** Number of Issues Published Annually: 52. **6.** Annual Subscription Price: \$40, includes sales tax. **7.** Complete Mailing Address of Known Office of Publication (Not printer): 661 Garden Commerce Parkway, Suite 180, Winter Garden, FL 34787. Contact Person: Anne H. Shumate; Telephone: (877-231-8834) **8.** Complete Mailing Address of Headquarters or General Business Office of Publisher (Not Printer): 661 Garden Commerce Parkway, Suite 180, Winter Garden, FL 34787. **9.** Full Names and Complete Mailing Addresses of Publisher, Editor, and Managing Editor: (Publisher) Mike Eng, 661 Garden Commerce Parkway, Suite 180, Winter Garden, FL 34787. (Editor) Mike Eng, 661 Garden Commerce Parkway, Suite 180, Winter Garden, FL 34787. (Managing Editor) Mike Eng, 661 Garden Commerce Parkway, Suite 180, Winter Garden, FL 34787. **10.** Owner (If the publication is owned by a corporation, give the name and address of the corporation immediately followed by the names and addresses of all stockholders owning or holding 1 percent or more of the total amount of stock. If not owned by a corporation, give the names and addresses of the individual owners. If owned by a partnership or other unincorporated firm, give its name and address, as well as those of each individual owner. If the publication is published by a nonprofit organization, give its name and address.) Gulf Coast Review, Inc., 5570 Gulf of Mexico Dr., Longboat Key, FL 34228. **11.** Known Bondholders, Mortgagees, and Other Security Holders Owning or Holding 1 Percent or More of Total Amount of Bonds, Mortgages or Other Securities. (If there are none, so state): None. **13.** Publication Title: West Orange Times. **14.** Issue Date for Circulation Data Below: 9/10/20. **15.** Extent and Nature of Circulation: Average No. Copies Each Issue During Preceding 12 Months. Actual No. Copies of Single Issue Published Nearest to Filing Date. **15A.** Total No. of Copies (Net Press Run): 623 (average), 580 (actual). **15B.** Paid Distribution: (1) Outside County Paid Mail Subscriptions Stated on Form 3541. (Include advertiser's proof and exchange copies): 26 (average), 25 (actual). (2) In-County Paid Mail Subscriptions Stated on Form 3541 (Include advertiser's proof and exchange copies): 330 (average), 308 (actual). (3) Sales Through Dealers and Carriers, Street Vendors, Counter Sales, and Other Non-USPS Paid Distribution: 17 (average), 19 (actual). (4) Distributed by Other Mail Classes Through the USPS: 0 (average), 0 (actual). **C.** Total Paid Circulation [Sum of 15B (1), (2), (3), and (4)]: 373 (average), 352 (actual). **D.** Free Distribution (by Mail and Outside the Mail): (1) Outside County Free Copies Stated on PS Form 3541: 5 (average), 6 (actual). (2) In-County Free Copies Stated on PS Form 3541: 46 (average), 48 (actual). (3) Free Distribution by Other Mail Classes Through the USPS: 0 (average), 0 (actual). (4) Free Distribution Outside the Mail: 0 (average), 0 (actual). **E.** Total Free Distribution [Sum of 15D (1), (2), (3), and (4)]: 156 (average), 177 (actual). **F.** Total Distribution (Sum of 15C and 15E): 529 (average), 529 (actual). **G.** Copies Not Distributed: 94 (average), 51 (actual). **H.** Total (Sum of 15F and 15G): 623 (average), 580 (actual). **I.** Percent Paid and/or Requested Circulation (15C divided by 15F times 100): 70.51% (average), 66.54% (actual). **16.** Publication of Statement of Ownership: 9/24/20. **17.** Signature and Title of Editor, Publisher, Business Manager, or Owner. /s/ Mike Eng, Date 9/24/2020.

ORANGE COUNTY

FIRST INSERTION

**CITY OF OCOEE
NOTICE OF PUBLIC HEARING
LARGE SCALE PRELIMINARY/FINAL SITE PLAN
FOR OCOEE VILLAGE CENTER
"ALLURE AT OCOEE VILLAGE CENTER APARTMENTS"
CASE NUMBER: LS-2019-007**

NOTICE IS HEREBY GIVEN, pursuant to Article IV, Sections 4-3A(4), of the City of Ocoee Land Development Code, that on **TUESDAY, OCTOBER 6, 2020, AT 6:15 P.M.** or as soon thereafter as practical, the **OCOEE CITY COMMISSION** will hold a **PUBLIC HEARING** at the City of Ocoee Commission Chambers, 150 North Lakeshore Drive, Ocoee, Florida, to consider the Preliminary/Final Site Plan for Allure at Ocoee Village Center Apartments. The parcel identification number is 05-22-28-0000-00-040 and is located on Clarcona Ocoee Road, east of the 429 Expressway. The parcel contains 23.67 acres, of which 15.63 acres will be the Allure Apartments. The proposed use for this project is a four-story 320-unit multi-family development with a 10,000 s.f. Clubhouse.

All interested parties are invited to be heard during the public hearing portion of the meeting. City Hall is closed to the public and is subject to change based on the Governor's Executive Order. This meeting is broadcasted live on **Spectrum Channel 493** with a live stream at www.Ocoee.org/197/Ocoee-TV. Any interested party is invited to offer comments and/or questions during the hearing by emailing citizens@ocoee.org or calling **407-554-7118** or by **registering in advance** by emailing citizens@ocoee.org or calling **407-905-3105** and City staff will call you during the live meeting. A complete case file, including a complete legal description by metes and bounds, may be examined upon request by phone or email through the Ocoee Planning Department at 407-905-3157 or mrivera@ocoee.org. The City Commission may continue this public hearing to other dates and times, as it deems necessary. Any interested party shall be advised of the dates, times, and places of any continuation of these or continued public hearings shall be announced during the hearing and no further notices regarding these matters will be published. You are advised that any person who desires to appeal any decision made at the public hearings will need a record of the proceedings and for this purpose may need to ensure that a verbatim record of the proceedings is made which includes the testimony and evidence upon which the appeal is based. Persons with disabilities needing assistance to participate in any of these proceedings should contact the City Clerk's Office 48 hours in advance of the meeting at 407-905-3105.

September 24, 2020

20-03793W

FIRST INSERTION

**CITY OF OCOEE
NOTICE OF PUBLIC HEARING
LARGE SCALE PRELIMINARY/FINAL SITE PLAN
FOR OCOEE VILLAGE CENTER
"SOUTHEAST COMMERCIAL"
CASE NUMBER: LS-2019-009**

NOTICE IS HEREBY GIVEN, pursuant to Article IV, Sections 4-3A(4), of the City of Ocoee Land Development Code, that on **TUESDAY, OCTOBER 6, 2020, AT 6:15 P.M.** or as soon thereafter as practical, the **OCOEE CITY COMMISSION** will hold a **PUBLIC HEARING** at the City of Ocoee Commission Chambers, 150 North Lakeshore Drive, Ocoee, Florida, to consider the Preliminary/Final Site Plan for Southeast Commercial at Ocoee Village Center. The parcel identification number is 05-22-28-0000-00-004 and is located on Clarcona Ocoee Road, east of the 429 Expressway. The parcel contains 47.28 acres of which 4.71 acres will be Southeast Commercial. The developer is proposing a mixed-use development to be split into two (2) phases. Phase one (1) is proposing a 14,000 s.f. building mixed with retail and restaurants, and a 5,000 s.f. gas station with a convenience store. Phase two (2) is proposing a 4,000 s.f. quick service restaurant.

All interested parties are invited to be heard during the public hearing portion of the meeting. City Hall is closed to the public and is subject to change based on the Governor's Executive Order. This meeting is broadcasted live on **Spectrum Channel 493** with a live stream at www.Ocoee.org/197/Ocoee-TV. Any interested party is invited to offer comments and/or questions during the hearing by emailing citizens@ocoee.org or calling **407-554-7118** or by **registering in advance** by emailing citizens@ocoee.org or calling **407-905-3105** and City staff will call you during the live meeting. A complete case file, including a complete legal description by metes and bounds, may be examined upon request by phone or email through the Ocoee Planning Department at 407-905-3157 or mrivera@ocoee.org. The City Commission may continue this public hearing to other dates and times, as it deems necessary. Any interested party shall be advised of the dates, times, and places of any continuation of these or continued public hearings shall be announced during the hearing and no further notices regarding these matters will be published. You are advised that any person who desires to appeal any decision made at the public hearings will need a record of the proceedings and for this purpose may need to ensure that a verbatim record of the proceedings is made which includes the testimony and evidence upon which the appeal is based. Persons with disabilities needing assistance to participate in any of these proceedings should contact the City Clerk's Office 48 hours in advance of the meeting at 407-905-3105.

September 24, 2020

20-03794W

FIRST INSERTION

**NOTICE OF PUBLIC HEARING
CITY OF WINTER GARDEN, FLORIDA**

Notice is hereby given that the City of Winter Garden Planning and Zoning Board will, on October 5, 2020 at 6:30 p.m. or as soon after as possible, hold a public hearing in the City Commission Chambers located at 300 West Plant Street, Winter Garden, Florida in order to review a Special Exception Permit request for a property located at 329 South Dillard Street in Winter Garden, Florida. If approved, this Special Exception Permit will allow a retail sales and showroom in C-3 Professional Office District.

You can attend in person or to participate in the Planning & Zoning Board's virtual public hearing, please click on the link to register online at: <http://www.cvgdn.com/agendacenter>

Please visit the aforementioned website(s) in the days prior to the scheduled public hearings for more information about the public hearings, including any potential changes to the meeting location.

Copies of the proposed request may be inspected by the public between the hours of 8:00 a.m. and 5:00 p.m. Monday through Friday of each week, except for legal holidays, at the Planning & Zoning Division in City Hall, 300 West Plant Street, Winter Garden, Florida.

Any and all support or objections will be heard at this time. If no valid objections are presented to the contrary, consideration will be given for granting this request. Persons wishing to appeal any decision made by the Planning and Zoning Board at such hearing will need a record of the proceedings and for such purpose you may need to ensure that a verbatim record of the proceedings is made, which includes the testimony and evidence upon which the appeal is based. The City does not provide this verbatim record. Persons with disabilities needing special accommodations to participate in this public hearing should contact the City Clerk's Office at (407) 656-4111 at least 48 hours prior to the meeting. For more information, please call Shane Friedman at (407) 656-4111 ext. 2026.

Location Map

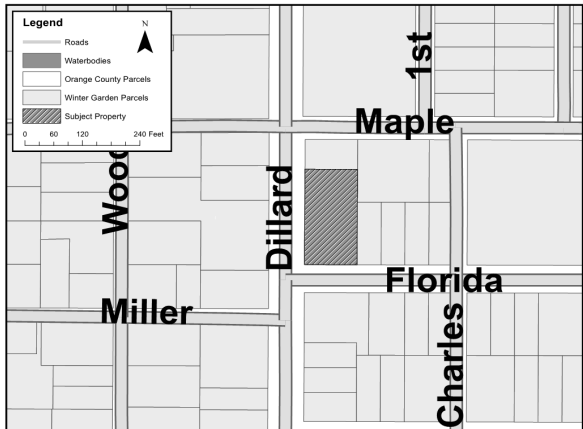

September 24, 2020

20-03728W

FIRST INSERTION

**CITY OF OCOEE
NOTICE OF PUBLIC HEARING TO CONSIDER THE
PUBLIC SCHOOL FACILITY ELEMENT
LARGE SCALE COMPREHENSIVE PLAN AMENDMENT
CASE NUMBER: CPA-2020-002**

NOTICE IS HEREBY GIVEN given that the **OCOEE CITY COMMISSION** will consider adoption of Ordinance No. 2020-019, thereby adopting a Large-Scale Amendment, amending the Public-School Facility Element, updating the language to remove the requirement for a Capacity Enhancement Agreement.

The **OCOEE CITY COMMISSION** will hold a public hearing on the proposed Large-Scale Amendment on **TUESDAY, OCTOBER 6, 2020, AT 6:15 PM** or as soon thereafter as practical. The public hearing will be held in the City Hall Commission Chambers located at 150 North Lakeshore Drive, Ocoee.

ORDINANCE NO. 2020-019

AN ORDINANCE OF THE CITY OF OCOEE, FLORIDA, AMENDING THE CITY OF OCOEE COMPREHENSIVE PLAN AS ADOPTED IN 1991, AS AMENDED; AMENDING THE PUBLIC SCHOOL FACILITY ELEMENT, OBJECTIVE 1.3, POLICY 1.3.1, OF THE OCOEE COMPREHENSIVE PLAN TO AMEND THE PUBLIC SCHOOL FACILITY ELEMENT, UPDATING LANGUAGE TO REQUIRE THE CITY TO SEEK INPUT FROM ORANGE COUNTY PUBLIC SCHOOLS RELATING TO SCHOOL CAPACITY WHERE A DEVELOPER-INITIATED COMPREHENSIVE PLAN AMENDMENT OR REZONING WILL INCREASE RESIDENTIAL DENSITY, REMOVING THE REQUIREMENT FOR A CAPACITY ENHANCEMENT AGREEMENT; PROVIDING FOR TRANSMITTAL; AUTHORIZING THE REVISION OF THE CITY COMPREHENSIVE PLAN; PROVIDING FOR SEVERABILITY; PROVIDING FOR AN EFFECTIVE DATE.

All interested parties are invited to be heard during the public hearing portion of the meeting. City Hall is closed to the public and is subject to change based on the Governor's Executive Order. This meeting is broadcasted live on **Spectrum Channel 493** with a live stream at www.Ocoee.org/197/Ocoee-TV. Any interested party is invited to offer comments and/or questions during the hearing by emailing citizens@ocoee.org or calling **407-554-7118** or by **registering in advance** by emailing citizens@ocoee.org or calling **407-905-3105** and City staff will call you during the live meeting. A complete case file, including a complete legal description by metes and bounds, may be examined upon request by phone or email through the Ocoee Planning Department at 407-905-3157 or mrivera@ocoee.org. The City Commission may continue this public hearing to other dates and times, as it deems necessary. Any interested party shall be advised of the dates, times, and places of any continuation of these or continued public hearings shall be announced during the hearing and no further notices regarding these matters will be published. You are advised that any person who desires to appeal any decision made at the public hearings will need a record of the proceedings and for this purpose may need to ensure that a verbatim record of the proceedings is made which includes the testimony and evidence upon which the appeal is based. Persons with disabilities needing assistance to participate in any of these proceedings should contact the City Clerk's Office 48 hours in advance of the meeting at 407-905-3105.

September 24, 2020

20-03792W

FIRST INSERTION

**CITY OF OCOEE
NOTICE OF PUBLIC HEARING
SUBSTANTIAL AMENDMENT TO THE
PLANNED UNIT DEVELOPMENT (PUD) FOR
OCOEE VILLAGE CENTER PUD
CASE NUMBER: RZ-19-10-11**

NOTICE IS HEREBY GIVEN, pursuant to Article I, Section 1-10, Article IV, Section 4-5, and Article V, Section 5-9, of the City of Ocoee Land Development Code, that on **TUESDAY, OCTOBER 6, 2020, AT 6:15 P.M.** or as soon thereafter as practical, the **OCOEE CITY COMMISSION** will hold a **PUBLIC HEARING** at the City of Ocoee Commission Chambers, 150 North Lakeshore Drive, Ocoee, Florida, to consider the Substantial Amendment to the PUD for Ocoee Village Center. The property consists of three (3) parcels identified as parcel number(s) 05-22-28-0000-00-040, 05-22-28-0000-00-046, & 05-22-28-0000-00-004. The subject property is approximately 73.17 acres in size. The applicant is requesting a major modification to the PUD increasing the approved units of Townhomes from 196 to 232 Townhomes Units, and increasing the number of units of Apartments from 316 units to 320 units.

AN ORDINANCE OF THE CITY OF OCOEE, FLORIDA APPROVING A SUBSTANTIAL AMENDMENT TO THE LAND USE PLAN FOR OCOEE VILLAGE CENTER PUD FOR CERTAIN REAL PROPERTY CONTAINING APPROXIMATELY 73.17 ACRES LOCATED ON THE NORTH AND SOUTH SIDES OF CLARCONA OCOEE ROAD, EAST SIDE OF SR 429 EXPRESSWAY, NORTH/SOUTH AND EAST SIDES OF NORTH LAKEWOOD AVENUE, AND AT THE EASTERN TERMINUS OF FULLERS CROSS ROAD AND NORTH LAKEWOOD AVENUE; FINDING CONSISTENCY WITH THE OCOEE COMPREHENSIVE PLAN; REPEALING INCONSISTENT ORDINANCES; PROVIDING FOR SEVERABLY; PROVIDING AN EFFECTIVE DATE.

All interested parties are invited to be heard during the public hearing portion of the meeting. City Hall is closed to the public and is subject to change based on the Governor's Executive Order. This meeting is broadcasted live on **Spectrum Channel 493** with a live stream at www.Ocoee.org/197/Ocoee-TV. Any interested party is invited to offer comments and/or questions during the hearing by emailing citizens@ocoee.org or calling **407-554-7118** or by **registering in advance** by emailing citizens@ocoee.org or calling **407-905-3105** and City staff will call you during the live meeting. A complete case file, including a complete legal description by metes and bounds, may be examined upon request by phone or email through the Ocoee Planning Department at 407-905-3157 or mrivera@ocoee.org. The City Commission may continue this public hearing to other dates and times, as it deems necessary. Any interested party shall be advised of the dates, times, and places of any continuation of these or continued public hearings shall be announced during the hearing and no further notices regarding these matters will be published. You are advised that any person who desires to appeal any decision made at the public hearings will need a record of the proceedings and for this purpose may need to ensure that a verbatim record of the proceedings is made which includes the testimony and evidence upon which the appeal is based. Persons with disabilities needing assistance to participate in any of these proceedings should contact the City Clerk's Office 48 hours in advance of the meeting at 407-905-3105.

September 24, 2020

20-03795W

FIRST INSERTION

**NOTICE TO CREDITORS
IN THE CIRCUIT COURT IN AND
FOR ORANGE COUNTY, FLORIDA
PROBATE DIVISION
FILE NO: 2020-CP-001697-O
IN RE: ESTATE OF
ALEXIS A. SMITH,
Deceased.**

The administration of the estate of ALEXIS A. SMITH, deceased, whose date of death was December 5, 2019, File Number 2020-CP-001697-O, is pending in the Circuit Court for Orange County, Florida, Probate Division, the address of which is Orange County Probate Court, 425 N. Orange Ave., Suite 355, Orlando, FL 32801. The name and address of the personal representative and the personal representative's attorney are set forth below.

All creditors of the decedent and other persons having claims or demands against decedent's estate, including unmaturred, contingent or unliquidated claims, on whom a copy of this notice is served must file their claims with this court WITHIN THE LATER OF 3 MONTHS AFTER THE DATE OF

THE FIRST PUBLICATION OF THIS NOTICE OR 30 DAYS AFTER THE DATE OF SERVICE OF A COPY OF THIS NOTICE ON THEM.

All other creditors of the decedent and other persons having claims or demands against decedent's estate, including unmaturred, contingent or unliquidated claims, must file their claims with this court WITHIN 3 MONTHS AFTER THE DATE OF THIS NOTICE.

ALL CLAIMS NOT SO FILED WILL BE FOREVER BARRED.

The date of first publication of this Notice is: September 24, 2020.

Personal Representative:
Barbara S. Smith
48 Highland Ave
Little Falls, NY 13365
Attorney for Personal Representative:
DENNIS J. O'CONNOR, ESQ.
Florida Bar No. 643297
Attorney for Petitioner
9999 NE 2nd Avenue, Suite 200
Miami Shores, FL 33138
(305)751-8556;
e-mail: doconnor@mfcflp.com
Sep. 24; Oct. 1, 2020 20-03735W

FIRST INSERTION

**CITY OF OCOEE
NOTICE OF PUBLIC HEARING
LARGE SCALE PRELIMINARY/FINAL SITE PLAN
FOR OCOEE VILLAGE CENTER
"TOWNHOMES"
CASE NUMBER: LS-2019-005**

NOTICE IS HEREBY GIVEN, pursuant to Article IV, Sections 4-3A(4), of the City of Ocoee Land Development Code, that on **TUESDAY, OCTOBER 6, 2020, AT 6:15 P.M.** or as soon thereafter as practical, the **OCOEE CITY COMMISSION** will hold a **PUBLIC HEARING** at the City of Ocoee Commission Chambers, 150 North Lakeshore Drive, Ocoee, Florida, to consider the Preliminary/Final Site Plan for the Townhomes at Ocoee Village Center. The parcel identification number is 05-22-28-0000-00-004 and is located on Clarcona Ocoee Road, east of the 429 Expressway. The parcel contains 47.28 acres, of which 34.49 acres will be the Townhomes at Ocoee Village Center. The proposed use is for 232-unit townhome community with amenities such as a Dog Park, Pavilion, Pool, Cabana, and a Playground.

All interested parties are invited to be heard during the public hearing portion of the meeting. City Hall is closed to the public and is subject to change based on the Governor's Executive Order. This meeting is broadcasted live on **Spectrum Channel 493** with a live stream at www.Ocoee.org/197/Ocoee-TV. Any interested party is invited to offer comments and/or questions during the hearing by emailing citizens@ocoee.org or calling **407-554-7118** or by **registering in advance** by emailing citizens@ocoee.org or calling **407-905-3105** and City staff will call you during the live meeting. A complete case file, including a complete legal description by metes and bounds, may be examined upon request by phone or email through the Ocoee Planning Department at 407-905-3157 or mrivera@ocoee.org. The City Commission may continue this public hearing to other dates and times, as it deems necessary. Any interested party shall be advised of the dates, times, and places of any continuation of these or continued public hearings shall be announced during the hearing and no further notices regarding these matters will be published. You are advised that any person who desires to appeal any decision made at the public hearings will need a record of the proceedings and for this purpose may need to ensure that a verbatim record of the proceedings is made which includes the testimony and evidence upon which the appeal is based. Persons with disabilities needing assistance to participate in any of these proceedings should contact the City Clerk's Office 48 hours in advance of the meeting at 407-905-3105.

September 24, 2020

20-03796W

FIRST INSERTION

**NOTICE TO CREDITORS
IN THE CIRCUIT COURT FOR
ORANGE COUNTY, FLORIDA
PROBATE DIVISION
File No.: 2020-CP-001202-O
IN RE: ESTATE OF
WILLIAM LLOYD GALLANT,
Deceased.**

The administration of the estate of WILLIAM LLOYD GALLANT, deceased, whose date of death was June 15, 2018, is pending in the Circuit Court for ORANGE County, Florida, Probate Division, the address of which is 425 N. Orange Ave., Suite 350, Orlando, FL 32801. The names and addresses of the personal representative and the personal representative's attorney are set forth below.

All creditors of the decedent and other persons having claims or demands against decedent's estate on whom a copy of this notice is required to be served must file their claims with this court ON OR BEFORE THE LATER OF 3 MONTHS AFTER THE TIME OF THE FIRST PUBLICATION OF THIS NOTICE OR 30 DAYS AFTER THE DATE OF SERVICE OF A COPY OF THIS NOTICE ON THEM.

All other creditors of the decedent and other persons having claims or demands against decedent's estate must file their claims with the court WITHIN 3 MONTHS AFTER THE DATE OF THE FIRST PUBLICATION OF THIS NOTICE.

ALL CLAIMS NOT FILED WITHIN THE TIME PERIODS SET FORTH IN FLORIDA STATUTES SECTION 733.702 WILL BE FOREVER BARRED.

NOTWITHSTANDING THE TIME PERIODS SET FORTH ABOVE, ANY CLAIM FILED TWO (2) YEARS OR MORE AFTER THE DECEDENT'S DATE OF DEATH IS BARRED.

The date of first publication of this notice is September 24, 2020.

Personal Representative:
DAVID GALLANT
1219 Kenworth Drive
Apopka, Florida 32712
Attorney for Personal Representative:
RODOLFO SUAREZ, JR., ESQ.
Attorney
Florida Bar Number: 013201
2950 SW 27 Avenue, Ste 100
Miami, FL 33133
Telephone: (305) 448-4244
E-Mail: rudy@suarezlawyers.com
Sep. 24; Oct. 1, 2020 20-03734W

FIRST INSERTION

**NOTICE TO CREDITORS
IN THE CIRCUIT COURT FOR
ORANGE COUNTY, FLORIDA
PROBATE DIVISION
File No. 2020-CP-002290-O
IN RE: ESTATE OF
DEOWANAND RHUGNANAN
Deceased.**

The administration of the estate of DEOWANAND RHUGNANAN, deceased, whose date of death was June 14, 2020, is pending in the Circuit Court for Orange County, Florida, Probate Division, the address of which is 425 N. Orange Ave., Suite 355, Orlando, FL 32801. The names and addresses of the personal representative and the personal representative's attorney are set forth below.

All creditors of the decedent and other persons having claims or demands against decedent's estate, on whom a copy of this notice is required to be served, must file their claims with this court ON OR BEFORE THE LATER OF 3 MONTHS AFTER THE TIME OF THE FIRST PUBLICATION OF THIS NOTICE OR 30 DAYS AFTER THE DATE OF SERVICE OF A COPY OF THIS NOTICE ON THEM.

All other creditors of the decedent and other persons having claims or demands against decedent's estate must file their claims with this court WITHIN 3 MONTHS AFTER THE DATE OF THE FIRST PUBLICATION OF THIS NOTICE.

ALL CLAIMS NOT FILED WITHIN THE TIME PERIODS SET FORTH IN FLORIDA STATUTES SECTION 733.702 WILL BE FOREVER BARRED.

NOTWITHSTANDING THE TIME PERIOD SET FORTH ABOVE, ANY CLAIM FILED TWO (2) YEARS OR MORE AFTER THE DECEDENT'S DATE OF DEATH IS BARRED.

The date of first publication of this notice is: September 24, 2020.

**/s/ Ramdai Rhugnanan
Personal Representative**
3025 Pell Mell Dr.
Orlando, FL 32818

**/s/ Donald Gervase
Attorney for Personal Representative**
Florida Bar No. 95584
Provision Law PLLC
310 S. Dillard St. Ste 140
Winter Garden, FL 34787
Telephone: 407-287-6767
Email: dgervase@provisionlaw.com
Sep. 24; Oct. 1, 2020 20-03787W

FIRST INSERTION

**NOTICE TO CREDITORS
IN THE CIRCUIT COURT FOR OR-
ANGE COUNTY, FLORIDA
PROBATE DIVISION
File No. 2020-CP-001833
Division Probate
IN RE: ESTATE OF
HELEN LUFF
Deceased.**

The administration of the estate of HELEN LUFF, deceased, whose date of death was June 14, 2020; is pending in the Circuit Court for Orange County, Florida, Probate Division, the address of which is 425 N. Orange Avenue, Suite 355, Orlando, FL 32801. The names and addresses of the personal representative and the personal representative's attorney are set forth below.

All creditors of the decedent and other persons having claims or demands against decedent's estate, on whom a copy of this notice is required to be served must file their claims with this court ON OR BEFORE THE LATER OF 3 MONTHS AFTER THE TIME OF THE FIRST PUBLICATION OF THIS NOTICE OR 30 DAYS AFTER THE DATE OF SERVICE OF A COPY OF THIS NOTICE ON THEM.

All other creditors of the decedent and other persons having claims or demands against decedent's estate must

file their claims with this court WITHIN 3 MONTHS AFTER THE DATE OF THE FIRST PUBLICATION OF THIS NOTICE.

ALL CLAIMS NOT FILED WITHIN THE TIME PERIOD SET FORTH IN FLORIDA STATUTES SECTION 733.702 WILL BE FOREVER BARRED.

NOTWITHSTANDING THE TIME PERIODS SET FORTH ABOVE, ANY CLAIM FILED TWO (2) YEARS OR MORE AFTER THE DECEDENT'S DATE OF DEATH IS BARRED.

The date of first publication of this notice is: September 24, 2020.

**GREGORY R. LUFF
Personal Representative**
14252 Lake Preserve Boulevard
Orlando, FL 32824
DAVE M. EVANS, JR.
Attorney for Personal Representative
Email: devans@hgree.com
Secondary Email:
service@hgree.com
Florida Bar No. 1013511
H. GREG LEE, P.A.
2601 Cattleman Road, Suite 503
Sarasota, FL 34232
Telephone: (941) 954-0067
Facsimile: (941) 365-1492
Sep. 24; Oct. 1, 2020 20-03673W

ORANGE COUNTY

FIRST INSERTION

NOTICE OF APPLICATION FOR TAX DEED

NOTICE IS HEREBY GIVEN that JESSE M POWELL (A MINOR) FUTMA-ROBERT E POWELL CUST FOR the holder of the following certificate has filed said certificate for a TAX DEED to be issued thereon. The Certificate number and year of issuance, the description of the property, and the names in which it was assessed are as follows:

CERTIFICATE NUMBER: 2018-1673

YEAR OF ISSUANCE: 2018

DESCRIPTION OF PROPERTY: E1/2 OF NE1/4 OF NE1/4 OF SW1/4 & E1/2 OF SE1/4 OF SE1/4 OF NW1/4 & W1/2 OF NW1/4 OF NW1/4 OF NW1/4 OF SE1/4 ALL IN SEC 27-20-28 (LESS CO RD R/W)

PARCEL ID # 27-20-28-0000-00-033

Name in which assessed: HARMONY 523 LLC

ALL of said property being in the County of Orange, State of Florida. Unless such certificate shall be redeemed according to law, the property described in such certificate will be sold to the highest bidder online at www.orange.realtaxdeed.com scheduled to begin at 10:00 a.m. ET, Nov 05, 2020.

Dated: Sep 17, 2020
Phil Diamond
County Comptroller
Orange County, Florida
By: M Hildebrandt
Deputy Comptroller
Sep. 24; Oct. 1, 8, 15, 2020

20-03736W

FIRST INSERTION

NOTICE OF APPLICATION FOR TAX DEED

NOTICE IS HEREBY GIVEN that JESSE M POWELL (A MINOR) FUTMA-ROBERT E POWELL CUST FOR the holder of the following certificate has filed said certificate for a TAX DEED to be issued thereon. The Certificate number and year of issuance, the description of the property, and the names in which it was assessed are as follows:

CERTIFICATE NUMBER: 2018-7338

YEAR OF ISSUANCE: 2018

DESCRIPTION OF PROPERTY: MAITLAND HOUSE CONDO CB 1/20 UNIT 103 & 1/28 INT IN LOT A

PARCEL ID # 36-21-29-5471-01-030

Name in which assessed: THOMAS DAVID PECK, THOMAS MANLEY PECK

ALL of said property being in the County of Orange, State of Florida. Unless such certificate shall be redeemed according to law, the property described in such certificate will be sold to the highest bidder online at www.orange.realtaxdeed.com scheduled to begin at 10:00 a.m. ET, Nov 05, 2020.

Dated: Sep 17, 2020
Phil Diamond
County Comptroller
Orange County, Florida
By: M Hildebrandt
Deputy Comptroller
Sep. 24; Oct. 1, 8, 15, 2020

20-03742W

FIRST INSERTION

NOTICE OF APPLICATION FOR TAX DEED

NOTICE IS HEREBY GIVEN that FLORIDA TAX CERTIFICATE FUND 1 MUNICIPAL TAX LLC the holder of the following certificate has filed said certificate for a TAX DEED to be issued thereon. The Certificate number and year of issuance, the description of the property, and the names in which it was assessed are as follows:

CERTIFICATE NUMBER: 2018-11982

YEAR OF ISSUANCE: 2018

DESCRIPTION OF PROPERTY: AVANZAR PHASE 1 CONDO CB 8/108 UNIT 2101

PARCEL ID # 15-23-29-0342-02-101

Name in which assessed: AVANZAR CONDOMINIUM ASSN INC

ALL of said property being in the County of Orange, State of Florida. Unless such certificate shall be redeemed according to law, the property described in such certificate will be sold to the highest bidder online at www.orange.realtaxdeed.com scheduled to begin at 10:00 a.m. ET, Nov 05, 2020.

Dated: Sep 17, 2020
Phil Diamond
County Comptroller
Orange County, Florida
By: M Hildebrandt
Deputy Comptroller
Sep. 24; Oct. 1, 8, 15, 2020

20-03748W

FIRST INSERTION

NOTICE OF APPLICATION FOR TAX DEED

NOTICE IS HEREBY GIVEN that ATCF II FLORIDA-A LLC the holder of the following certificate has filed said certificate for a TAX DEED to be issued thereon. The Certificate number and year of issuance, the description of the property, and the names in which it was assessed are as follows:

CERTIFICATE NUMBER: 2018-2148

YEAR OF ISSUANCE: 2018

DESCRIPTION OF PROPERTY: TOWN OF APOPKA A/109 LOT 26 BLK G

PARCEL ID # 09-21-28-0196-70-260

Name in which assessed: SOMOSA RAMDEEN

ALL of said property being in the County of Orange, State of Florida. Unless such certificate shall be redeemed according to law, the property described in such certificate will be sold to the highest bidder online at www.orange.realtaxdeed.com scheduled to begin at 10:00 a.m. ET, Nov 05, 2020.

Dated: Sep 17, 2020
Phil Diamond
County Comptroller
Orange County, Florida
By: M Hildebrandt
Deputy Comptroller
Sep. 24; Oct. 1, 8, 15, 2020

20-03737W

FIRST INSERTION

NOTICE OF APPLICATION FOR TAX DEED

NOTICE IS HEREBY GIVEN that LIEGE TAX LIENS LLC 18 the holder of the following certificate has filed said certificate for a TAX DEED to be issued thereon. The Certificate number and year of issuance, the description of the property, and the names in which it was assessed are as follows:

CERTIFICATE NUMBER: 2018-7512

YEAR OF ISSUANCE: 2018

DESCRIPTION OF PROPERTY: ZOM LEE OFFICE CENTER 1 CONDO CB 7/9 UNIT 201B

PARCEL ID # 02-22-29-9510-02-012

Name in which assessed: ROSEMARIE J SEAMAN

ALL of said property being in the County of Orange, State of Florida. Unless such certificate shall be redeemed according to law, the property described in such certificate will be sold to the highest bidder online at www.orange.realtaxdeed.com scheduled to begin at 10:00 a.m. ET, Nov 05, 2020.

Dated: Sep 17, 2020
Phil Diamond
County Comptroller
Orange County, Florida
By: M Hildebrandt
Deputy Comptroller
Sep. 24; Oct. 1, 8, 15, 2020

20-03743W

FIRST INSERTION

NOTICE OF APPLICATION FOR TAX DEED

NOTICE IS HEREBY GIVEN that FLORIDA TAX CERTIFICATE FUND 1 MUNICIPAL TAX LLC the holder of the following certificate has filed said certificate for a TAX DEED to be issued thereon. The Certificate number and year of issuance, the description of the property, and the names in which it was assessed are as follows:

CERTIFICATE NUMBER: 2018-12032

YEAR OF ISSUANCE: 2018

DESCRIPTION OF PROPERTY: LAKE TYLER CONDO CB 5/16 BLDG D UNIT 6

PARCEL ID # 15-23-29-4778-04-060

Name in which assessed: CARLOS WATSON

ALL of said property being in the County of Orange, State of Florida. Unless such certificate shall be redeemed according to law, the property described in such certificate will be sold to the highest bidder online at www.orange.realtaxdeed.com scheduled to begin at 10:00 a.m. ET, Nov 05, 2020.

Dated: Sep 17, 2020
Phil Diamond
County Comptroller
Orange County, Florida
By: M Hildebrandt
Deputy Comptroller
Sep. 24; Oct. 1, 8, 15, 2020

20-03749W

FIRST INSERTION

NOTICE OF APPLICATION FOR TAX DEED

NOTICE IS HEREBY GIVEN that ANGELA JESCHKE the holder of the following certificate has filed said certificate for a TAX DEED to be issued thereon. The Certificate number and year of issuance, the description of the property, and the names in which it was assessed are as follows:

CERTIFICATE NUMBER: 2018-3441

YEAR OF ISSUANCE: 2018

DESCRIPTION OF PROPERTY: GRACELAND 9/107 LOT 30

PARCEL ID # 02-22-28-3118-00-300

Name in which assessed: GILLETTE FIVE LLC, JEANNOT HYPOLITE

ALL of said property being in the County of Orange, State of Florida. Unless such certificate shall be redeemed according to law, the property described in such certificate will be sold to the highest bidder online at www.orange.realtaxdeed.com scheduled to begin at 10:00 a.m. ET, Nov 05, 2020.

Dated: Sep 17, 2020
Phil Diamond
County Comptroller
Orange County, Florida
By: M Hildebrandt
Deputy Comptroller
Sep. 24; Oct. 1, 8, 15, 2020

20-03738W

FIRST INSERTION

NOTICE OF APPLICATION FOR TAX DEED

NOTICE IS HEREBY GIVEN that MIKON FINANCIAL SERVICES INC AND OCEAN BANK the holder of the following certificate has filed said certificate for a TAX DEED to be issued thereon. The Certificate number and year of issuance, the description of the property, and the names in which it was assessed are as follows:

CERTIFICATE NUMBER: 2018-7873

YEAR OF ISSUANCE: 2018

DESCRIPTION OF PROPERTY: VILLAS AT SIGNAL HILL UNIT 1 6/116 LOT 71

PARCEL ID # 06-22-29-8894-00-710

Name in which assessed: DENNIS CARLTON BOMAR

ALL of said property being in the County of Orange, State of Florida. Unless such certificate shall be redeemed according to law, the property described in such certificate will be sold to the highest bidder online at www.orange.realtaxdeed.com scheduled to begin at 10:00 a.m. ET, Nov 05, 2020.

Dated: Sep 17, 2020
Phil Diamond
County Comptroller
Orange County, Florida
By: M Hildebrandt
Deputy Comptroller
Sep. 24; Oct. 1, 8, 15, 2020

20-03744W

FIRST INSERTION

NOTICE OF APPLICATION FOR TAX DEED

NOTICE IS HEREBY GIVEN that LIEGE TAX LIENS LLC 18 the holder of the following certificate has filed said certificate for a TAX DEED to be issued thereon. The Certificate number and year of issuance, the description of the property, and the names in which it was assessed are as follows:

CERTIFICATE NUMBER: 2018-12097

YEAR OF ISSUANCE: 2018

DESCRIPTION OF PROPERTY: PLAZA AT MILLENIUM CONDOMINIUM 8667/1664 UNIT 118 BLDG 5

PARCEL ID # 15-23-29-7127-05-118

Name in which assessed: NESTIS INTERNATIONAL LLC

ALL of said property being in the County of Orange, State of Florida. Unless such certificate shall be redeemed according to law, the property described in such certificate will be sold to the highest bidder online at www.orange.realtaxdeed.com scheduled to begin at 10:00 a.m. ET, Nov 05, 2020.

Dated: Sep 17, 2020
Phil Diamond
County Comptroller
Orange County, Florida
By: M Hildebrandt
Deputy Comptroller
Sep. 24; Oct. 1, 8, 15, 2020

20-03750W

FIRST INSERTION

NOTICE OF APPLICATION FOR TAX DEED

NOTICE IS HEREBY GIVEN that LIEGE TAX LIENS LLC 18 the holder of the following certificate has filed said certificate for a TAX DEED to be issued thereon. The Certificate number and year of issuance, the description of the property, and the names in which it was assessed are as follows:

CERTIFICATE NUMBER: 2018-5587

YEAR OF ISSUANCE: 2018

DESCRIPTION OF PROPERTY: RESERVE AT LAKE BUTLER SOUND UNIT 2 47/127 LOT 50

PARCEL ID # 19-23-28-7392-00-500

Name in which assessed: PATRICIA ALESANDRA CURCOVEZKI

ALL of said property being in the County of Orange, State of Florida. Unless such certificate shall be redeemed according to law, the property described in such certificate will be sold to the highest bidder online at www.orange.realtaxdeed.com scheduled to begin at 10:00 a.m. ET, Nov 05, 2020.

Dated: Sep 17, 2020
Phil Diamond
County Comptroller
Orange County, Florida
By: M Hildebrandt
Deputy Comptroller
Sep. 24; Oct. 1, 8, 15, 2020

20-03739W

FIRST INSERTION

NOTICE OF APPLICATION FOR TAX DEED

NOTICE IS HEREBY GIVEN that ATCF II FLORIDA-A LLC the holder of the following certificate has filed said certificate for a TAX DEED to be issued thereon. The Certificate number and year of issuance, the description of the property, and the names in which it was assessed are as follows:

CERTIFICATE NUMBER: 2018-8006

YEAR OF ISSUANCE: 2018

DESCRIPTION OF PROPERTY: ROSEMONT GREEN 7 8 9 CONDO CB 3/128 BLDG 9 UNIT 507

PARCEL ID # 08-22-29-7735-05-070

Name in which assessed: HUAIMING CHANG

ALL of said property being in the County of Orange, State of Florida. Unless such certificate shall be redeemed according to law, the property described in such certificate will be sold to the highest bidder online at www.orange.realtaxdeed.com scheduled to begin at 10:00 a.m. ET, Nov 05, 2020.

Dated: Sep 17, 2020
Phil Diamond
County Comptroller
Orange County, Florida
By: M Hildebrandt
Deputy Comptroller
Sep. 24; Oct. 1, 8, 15, 2020

20-03745W

FIRST INSERTION

NOTICE OF APPLICATION FOR TAX DEED

NOTICE IS HEREBY GIVEN that JESSE M POWELL (A MINOR) FUTMA-ROBERT E POWELL CUST FOR the holder of the following certificate has filed said certificate for a TAX DEED to be issued thereon. The Certificate number and year of issuance, the description of the property, and the names in which it was assessed are as follows:

CERTIFICATE NUMBER: 2018-12388

YEAR OF ISSUANCE: 2018

DESCRIPTION OF PROPERTY: TAMARIND CONDO PHASE 2 OR 3267/1423 BLDG F UNIT 205

PARCEL ID # 18-23-29-8526-06-205

Name in which assessed: CHRISTIANE RODRIGUES PFISTERER

ALL of said property being in the County of Orange, State of Florida. Unless such certificate shall be redeemed according to law, the property described in such certificate will be sold to the highest bidder online at www.orange.realtaxdeed.com scheduled to begin at 10:00 a.m. ET, Nov 05, 2020.

Dated: Sep 17, 2020
Phil Diamond
County Comptroller
Orange County, Florida
By: M Hildebrandt
Deputy Comptroller
Sep. 24; Oct. 1, 8, 15, 2020

20-03751W

FIRST INSERTION

NOTICE OF APPLICATION FOR TAX DEED

NOTICE IS HEREBY GIVEN that ANGELA JESCHKE the holder of the following certificate has filed said certificate for a TAX DEED to be issued thereon. The Certificate number and year of issuance, the description of the property, and the names in which it was assessed are as follows:

CERTIFICATE NUMBER: 2018-5898

YEAR OF ISSUANCE: 2018

DESCRIPTION OF PROPERTY: SANDPOINTE TOWNHOUSES SEC TWO 14/55 LOT 56

PARCEL ID # 27-23-28-7840-00-560

Name in which assessed: JIMMY E CLAY, JOANN CLAY

ALL of said property being in the County of Orange, State of Florida. Unless such certificate shall be redeemed according to law, the property described in such certificate will be sold to the highest bidder online at www.orange.realtaxdeed.com scheduled to begin at 10:00 a.m. ET, Nov 05, 2020.

Dated: Sep 17, 2020
Phil Diamond
County Comptroller
Orange County, Florida
By: M Hildebrandt
Deputy Comptroller
Sep. 24; Oct. 1, 8, 15, 2020

20-03740W

FIRST INSERTION

NOTICE OF APPLICATION FOR TAX DEED

NOTICE IS HEREBY GIVEN that LIEGE TAX LIENS LLC 18 the holder of the following certificate has filed said certificate for a TAX DEED to be issued thereon. The Certificate number and year of issuance, the description of the property, and the names in which it was assessed are as follows:

CERTIFICATE NUMBER: 2018-8546

YEAR OF ISSUANCE: 2018

DESCRIPTION OF PROPERTY: EVANS VILLAGE SECOND UNIT X/125 LOT 7 BLK J

PARCEL ID # 18-22-29-2535-10-070

Name in which assessed: AISAGATE INVESTMENT LIMITED

ALL of said property being in the County of Orange, State of Florida. Unless such certificate shall be redeemed according to law, the property described in such certificate will be sold to the highest bidder online at www.orange.realtaxdeed.com scheduled to begin at 10:00 a.m. ET, Nov 05, 2020.

Dated: Sep 17, 2020
Phil Diamond
County Comptroller
Orange County, Florida
By: M Hildebrandt
Deputy Comptroller
Sep. 24; Oct. 1, 8, 15, 2020

20-03746W

FIRST INSERTION

NOTICE OF APPLICATION FOR TAX DEED

NOTICE IS HEREBY GIVEN that CYPRESS TAX LLC the holder of the following certificate has filed said certificate for a TAX DEED to be issued thereon. The Certificate number and year of issuance, the description of the property, and the names in which it was assessed are as follows:

CERTIFICATE NUMBER: 2018-12632

YEAR OF ISSUANCE: 2018

DESCRIPTION OF PROPERTY: SKY LAKE OAK RIDGE SEC UNIT 2 Z/12 LOT 93

PARCEL ID # 23-23-29-8082-00-930

Name in which assessed: REBECA REMBIS

ALL of said property being in the County of Orange, State of Florida. Unless such certificate shall be redeemed according to law, the property described in such certificate will be sold to the highest bidder online at www.orange.realtaxdeed.com scheduled to begin at 10:00 a.m. ET, Nov 05, 2020.

Dated: Sep 17, 2020
Phil Diamond
County Comptroller
Orange County, Florida
By: M Hildebrandt
Deputy Comptroller
Sep. 24; Oct. 1, 8, 15, 2020

20-03752W

FIRST INSERTION

NOTICE OF APPLICATION FOR TAX DEED

NOTICE IS HEREBY GIVEN that FIG FL18 LLC the holder of the following certificate has filed said certificate for a TAX DEED to be issued thereon. The Certificate number and year of issuance, the description of the property, and the names in which it was assessed are as follows:

CERTIFICATE NUMBER: 2018-6897

YEAR OF ISSUANCE: 2018

DESCRIPTION OF PROPERTY: 20170025424 ERROR IN LEGAL DESC: MCNEILS ORANGE VILLA G/6 BEING A PART OF LOT 95 DESC AS: COMM AT THE SW COR OF SEC 29-21-29 TH RUN N00-07-54W 504.57 FT TH N89-52-06E 25 FT TO POB TH N00-07-54W 110 FT TH N89-52-06E 100 FT TH 800-07-54E 110 FT TH S89-52-06W 100 FT TO POB

PARCEL ID # 29-21-29-5384-00-954

Name in which assessed: WAYNE F D WATT

ALL of said property being in the County of Orange, State of Florida. Unless such certificate shall be redeemed according to law, the property described in such certificate will be sold to the highest bidder online at www.orange.realtaxdeed.com scheduled to begin at 10:00 a.m. ET, Nov 05, 2020.

Dated: Sep 17, 2020
Phil Diamond
County Comptroller
Orange County, Florida
By: M Hildebrandt
Deputy Comptroller
Sep. 24; Oct. 1, 8, 15, 2020

20-03741W

FIRST INSERTION

NOTICE OF APPLICATION FOR TAX DEED

NOTICE IS HEREBY GIVEN that FIG FL18 LLC the holder of the following certificate has filed said certificate for a TAX DEED to be issued thereon. The Certificate number and year of issuance, the description of the property, and the names in which it was assessed are as follows:

CERTIFICATE NUMBER: 2018-10902

YEAR OF ISSUANCE: 2018

DESCRIPTION OF PROPERTY: ANGBILT ADDITION H/79 LOT 7 BLK 53

PARCEL ID # 03-23-29-0180-53-070

ORANGE COUNTY

FIRST INSERTION

NOTICE OF APPLICATION FOR TAX DEED

NOTICE IS HEREBY GIVEN that FIG FL18 LLC the holder of the following certificate has filed said certificate for a TAX DEED to be issued thereon. The Certificate number and year of issuance, the description of the property, and the names in which it was assessed are as follows:

CERTIFICATE NUMBER: 2018-14723

YEAR OF ISSUANCE: 2018

DESCRIPTION OF PROPERTY: SHERBROOKE UNIT NO 1 1/111 LOT 2

PARCEL ID # 09-22-30-7970-00-20

Name in which assessed: WILLARD AND BETTY LEE REVOCABLE TRUST

ALL of said property being in the County of Orange, State of Florida. Unless such certificate shall be redeemed according to law, the property described in such certificate will be sold to the highest bidder online at www.orange.realtaxdeed.com scheduled to begin at 10:00 a.m. ET, Nov 05, 2020.

Dated: Sep 17, 2020
Phil Diamond
County Comptroller
Orange County, Florida
By: M Hildebrandt
Deputy Comptroller
Sep. 24; Oct. 1, 8, 15, 2020
20-03754W

FIRST INSERTION

NOTICE OF APPLICATION FOR TAX DEED

NOTICE IS HEREBY GIVEN that FLORIDA TAX CERTIFICATE FUND 1 MUNICIPAL TAX LLC the holder of the following certificate has filed said certificate for a TAX DEED to be issued thereon. The Certificate number and year of issuance, the description of the property, and the names in which it was assessed are as follows:

CERTIFICATE NUMBER: 2018-16348

YEAR OF ISSUANCE: 2018

DESCRIPTION OF PROPERTY: METRO AT MICHIGAN PARK CONDO 8154/859 UNIT 6 BLDG 1944

PARCEL ID # 05-23-30-5625-44-006

Name in which assessed: MIRVAHAB KAUMOV

ALL of said property being in the County of Orange, State of Florida. Unless such certificate shall be redeemed according to law, the property described in such certificate will be sold to the highest bidder online at www.orange.realtaxdeed.com scheduled to begin at 10:00 a.m. ET, Nov 05, 2020.

Dated: Sep 17, 2020
Phil Diamond
County Comptroller
Orange County, Florida
By: M Hildebrandt
Deputy Comptroller
Sep. 24; Oct. 1, 8, 15, 2020
20-03760W

FIRST INSERTION

NOTICE OF APPLICATION FOR TAX DEED

NOTICE IS HEREBY GIVEN that FIG FL18 LLC the holder of the following certificate has filed said certificate for a TAX DEED to be issued thereon. The Certificate number and year of issuance, the description of the property, and the names in which it was assessed are as follows:

CERTIFICATE NUMBER: 2018-18994

YEAR OF ISSUANCE: 2018

DESCRIPTION OF PROPERTY: EAST ORLANDO ESTATES SECTION A X/57 THE N1/2 LOT 267

PARCEL ID # 15-22-32-2330-02-671

Name in which assessed: MARIA HERNANDEZ

ALL of said property being in the County of Orange, State of Florida. Unless such certificate shall be redeemed according to law, the property described in such certificate will be sold to the highest bidder online at www.orange.realtaxdeed.com scheduled to begin at 10:00 a.m. ET, Nov 05, 2020.

Dated: Sep 17, 2020
Phil Diamond
County Comptroller
Orange County, Florida
By: M Hildebrandt
Deputy Comptroller
Sep. 24; Oct. 1, 8, 15, 2020
20-03766W



FIRST INSERTION

NOTICE OF APPLICATION FOR TAX DEED

NOTICE IS HEREBY GIVEN that FLORIDA TAX CERTIFICATE FUND 1 MUNICIPAL TAX LLC the holder of the following certificate has filed said certificate for a TAX DEED to be issued thereon. The Certificate number and year of issuance, the description of the property, and the names in which it was assessed are as follows:

CERTIFICATE NUMBER: 2018-15144

YEAR OF ISSUANCE: 2018

DESCRIPTION OF PROPERTY: AUDUBON PARK BOBOLINK SECTION T/110 LOT 10 & E 10FT LOT 11 BLK 2

PARCEL ID # 20-22-30-0328-02-100

Name in which assessed: LILLIAN ROSARIO, GERARD MOSSEY

ALL of said property being in the County of Orange, State of Florida. Unless such certificate shall be redeemed according to law, the property described in such certificate will be sold to the highest bidder online at www.orange.realtaxdeed.com scheduled to begin at 10:00 a.m. ET, Nov 05, 2020.

Dated: Sep 17, 2020
Phil Diamond
County Comptroller
Orange County, Florida
By: M Hildebrandt
Deputy Comptroller
Sep. 24; Oct. 1, 8, 15, 2020
20-03755W

FIRST INSERTION

NOTICE OF APPLICATION FOR TAX DEED

NOTICE IS HEREBY GIVEN that FLORIDA TAX CERTIFICATE FUND 1 MUNICIPAL TAX LLC the holder of the following certificate has filed said certificate for a TAX DEED to be issued thereon. The Certificate number and year of issuance, the description of the property, and the names in which it was assessed are as follows:

CERTIFICATE NUMBER: 2018-16899

YEAR OF ISSUANCE: 2018

DESCRIPTION OF PROPERTY: CHICKASAW WOODS FIRST ADDITION 6/17 LOT 27 BLK B

PARCEL ID # 12-23-30-1300-02-270

Name in which assessed: HSIN MING SHIEH, EMILY WANJU LEE

ALL of said property being in the County of Orange, State of Florida. Unless such certificate shall be redeemed according to law, the property described in such certificate will be sold to the highest bidder online at www.orange.realtaxdeed.com scheduled to begin at 10:00 a.m. ET, Nov 05, 2020.

Dated: Sep 17, 2020
Phil Diamond
County Comptroller
Orange County, Florida
By: M Hildebrandt
Deputy Comptroller
Sep. 24; Oct. 1, 8, 15, 2020
20-03761W

FIRST INSERTION

NOTICE OF APPLICATION FOR TAX DEED

NOTICE IS HEREBY GIVEN that LUKE R POWELL (A MINOR) FUMAROBERT E POWELL CUST FOR the holder of the following certificate has filed said certificate for a TAX DEED to be issued thereon. The Certificate number and year of issuance, the description of the property, and the names in which it was assessed are as follows:

CERTIFICATE NUMBER: 2018-19072

YEAR OF ISSUANCE: 2018

DESCRIPTION OF PROPERTY: UNRECORDED PLAT EAST ORLANDO ESTATES SECTION 1 THE N 135 FT OF TR 74 DESC AS BEG 1952.85 FT E & 492.6 FT S OF W1/4 COR OF SEC TH RUN N 135 FT W 425.24 FT S 18 DEG E 79.13 FT S 60 FT E 400 FT TO POB

PARCEL ID # 15-22-32-2336-00-740

Name in which assessed: AMANDA L DURBIN

ALL of said property being in the County of Orange, State of Florida. Unless such certificate shall be redeemed according to law, the property described in such certificate will be sold to the highest bidder online at www.orange.realtaxdeed.com scheduled to begin at 10:00 a.m. ET, Nov 05, 2020.

Dated: Sep 17, 2020
Phil Diamond
County Comptroller
Orange County, Florida
By: M Hildebrandt
Deputy Comptroller
Sep. 24; Oct. 1, 8, 15, 2020
20-03767W

FIRST INSERTION

NOTICE OF APPLICATION FOR TAX DEED

NOTICE IS HEREBY GIVEN that FLORIDA TAX CERTIFICATE FUND 1 MUNICIPAL TAX LLC the holder of the following certificate has filed said certificate for a TAX DEED to be issued thereon. The Certificate number and year of issuance, the description of the property, and the names in which it was assessed are as follows:

CERTIFICATE NUMBER: 2018-15190

YEAR OF ISSUANCE: 2018

DESCRIPTION OF PROPERTY: JAMAJO J/88 LOT 9(LESS SLY 5 FT) & SLY 5 FT OF LOT 8 BLK W SEE 2182/1476 & 3308/2545 & 3848/2029 & 2030

PARCEL ID # 21-22-30-3932-23-090

Name in which assessed: MATTHEW JOHN BAUER

ALL of said property being in the County of Orange, State of Florida. Unless such certificate shall be redeemed according to law, the property described in such certificate will be sold to the highest bidder online at www.orange.realtaxdeed.com scheduled to begin at 10:00 a.m. ET, Nov 05, 2020.

Dated: Sep 17, 2020
Phil Diamond
County Comptroller
Orange County, Florida
By: M Hildebrandt
Deputy Comptroller
Sep. 24; Oct. 1, 8, 15, 2020
20-03756W

FIRST INSERTION

NOTICE OF APPLICATION FOR TAX DEED

NOTICE IS HEREBY GIVEN that FLORIDA TAX CERTIFICATE FUND 1 MUNICIPAL TAX LLC the holder of the following certificate has filed said certificate for a TAX DEED to be issued thereon. The Certificate number and year of issuance, the description of the property, and the names in which it was assessed are as follows:

CERTIFICATE NUMBER: 2018-16947

YEAR OF ISSUANCE: 2018

DESCRIPTION OF PROPERTY: EAST ORLANDO SECTION TWO Y/26 LOT 206

PARCEL ID # 13-23-30-2332-02-060

Name in which assessed: N BERNICE LACY, JEFFERY GLENN LACY

ALL of said property being in the County of Orange, State of Florida. Unless such certificate shall be redeemed according to law, the property described in such certificate will be sold to the highest bidder online at www.orange.realtaxdeed.com scheduled to begin at 10:00 a.m. ET, Nov 05, 2020.

Dated: Sep 17, 2020
Phil Diamond
County Comptroller
Orange County, Florida
By: M Hildebrandt
Deputy Comptroller
Sep. 24; Oct. 1, 8, 15, 2020
20-03762W

FIRST INSERTION

NOTICE OF APPLICATION FOR TAX DEED

NOTICE IS HEREBY GIVEN that FIG FL18 LLC the holder of the following certificate has filed said certificate for a TAX DEED to be issued thereon. The Certificate number and year of issuance, the description of the property, and the names in which it was assessed are as follows:

CERTIFICATE NUMBER: 2018-19101

YEAR OF ISSUANCE: 2018

DESCRIPTION OF PROPERTY: UNRECORDED PLAT EAST ORLANDO ESTATES SECTION 1 TR 191 DESC AS BEG 2472.4 FT N & 4712.85 FT E FROM W1/4 COR OF SEC 22-22-32 N 150 FT E 295 FT S 150 FT W 295 FT TO POB

PARCEL ID # 15-22-32-2336-01-910

Name in which assessed: BARBARA HELMICK

ALL of said property being in the County of Orange, State of Florida. Unless such certificate shall be redeemed according to law, the property described in such certificate will be sold to the highest bidder online at www.orange.realtaxdeed.com scheduled to begin at 10:00 a.m. ET, Nov 05, 2020.

Dated: Sep 17, 2020
Phil Diamond
County Comptroller
Orange County, Florida
By: M Hildebrandt
Deputy Comptroller
Sep. 24; Oct. 1, 8, 15, 2020
20-03768W

FIRST INSERTION

NOTICE OF APPLICATION FOR TAX DEED

NOTICE IS HEREBY GIVEN that AMERICAN TAX FUNDING LLC the holder of the following certificate has filed said certificate for a TAX DEED to be issued thereon. The Certificate number and year of issuance, the description of the property, and the names in which it was assessed are as follows:

CERTIFICATE NUMBER: 2018-15193

YEAR OF ISSUANCE: 2018

DESCRIPTION OF PROPERTY: J J KATES SUB R/25 LOT 18 BLK B

PARCEL ID # 21-22-30-4084-02-180

Name in which assessed: ALDA MAY SAUNDERS

ALL of said property being in the County of Orange, State of Florida. Unless such certificate shall be redeemed according to law, the property described in such certificate will be sold to the highest bidder online at www.orange.realtaxdeed.com scheduled to begin at 10:00 a.m. ET, Nov 05, 2020.

Dated: Sep 17, 2020
Phil Diamond
County Comptroller
Orange County, Florida
By: M Hildebrandt
Deputy Comptroller
Sep. 24; Oct. 1, 8, 15, 2020
20-03757W

FIRST INSERTION

NOTICE OF APPLICATION FOR TAX DEED

NOTICE IS HEREBY GIVEN that FIG FL18 LLC the holder of the following certificate has filed said certificate for a TAX DEED to be issued thereon. The Certificate number and year of issuance, the description of the property, and the names in which it was assessed are as follows:

CERTIFICATE NUMBER: 2018-17157

YEAR OF ISSUANCE: 2018

DESCRIPTION OF PROPERTY: CARDINAL PARK 2/104 LOT 33

PARCEL ID # 16-23-30-1616-00-330

Name in which assessed: DAMARIS RUIZ RODRIGUEZ

ALL of said property being in the County of Orange, State of Florida. Unless such certificate shall be redeemed according to law, the property described in such certificate will be sold to the highest bidder online at www.orange.realtaxdeed.com scheduled to begin at 10:00 a.m. ET, Nov 05, 2020.

Dated: Sep 17, 2020
Phil Diamond
County Comptroller
Orange County, Florida
By: M Hildebrandt
Deputy Comptroller
Sep. 24; Oct. 1, 8, 15, 2020
20-03763W

FIRST INSERTION

NOTICE OF APPLICATION FOR TAX DEED

NOTICE IS HEREBY GIVEN that FIG FL18 LLC the holder of the following certificate has filed said certificate for a TAX DEED to be issued thereon. The Certificate number and year of issuance, the description of the property, and the names in which it was assessed are as follows:

CERTIFICATE NUMBER: 2018-19184

YEAR OF ISSUANCE: 2018

DESCRIPTION OF PROPERTY: UNRECORDED PLAT BITHLO RANCHES THE S 180 FT OF S 320 FT OF E 1/2 OF W 1/2 OF E1/2 OF NW1/4 OF NE1/4 OF NE1/4 (LESS S 30 FT FOR RD R/W)

PARCEL ID # 21-22-32-0734-00-193

Name in which assessed: CARL B CORNELIUS

ALL of said property being in the County of Orange, State of Florida. Unless such certificate shall be redeemed according to law, the property described in such certificate will be sold to the highest bidder online at www.orange.realtaxdeed.com scheduled to begin at 10:00 a.m. ET, Nov 05, 2020.

Dated: Sep 17, 2020
Phil Diamond
County Comptroller
Orange County, Florida
By: M Hildebrandt
Deputy Comptroller
Sep. 24; Oct. 1, 8, 15, 2020
20-03769W

FIRST INSERTION

NOTICE OF APPLICATION FOR TAX DEED

NOTICE IS HEREBY GIVEN that FLORIDA TAX CERTIFICATE FUND 1 MUNICIPAL TAX LLC the holder of the following certificate has filed said certificate for a TAX DEED to be issued thereon. The Certificate number and year of issuance, the description of the property, and the names in which it was assessed are as follows:

CERTIFICATE NUMBER: 2018-15304

YEAR OF ISSUANCE: 2018

DESCRIPTION OF PROPERTY: RIVERBEND ESTATES 14/51 LOT 40 (LESS W 39.90 FT THEREOF)

PARCEL ID # 23-22-30-7453-00-400

Name in which assessed: MIRZA M AHMED

ALL of said property being in the County of Orange, State of Florida. Unless such certificate shall be redeemed according to law, the property described in such certificate will be sold to the highest bidder online at www.orange.realtaxdeed.com scheduled to begin at 10:00 a.m. ET, Nov 05, 2020.

Dated: Sep 17, 2020
Phil Diamond
County Comptroller
Orange County, Florida
By: M Hildebrandt
Deputy Comptroller
Sep. 24; Oct. 1, 8, 15, 2020
20-03758W

FIRST INSERTION

NOTICE OF APPLICATION FOR TAX DEED

NOTICE IS HEREBY GIVEN that FIG FL18 LLC the holder of the following certificate has filed said certificate for a TAX DEED to be issued thereon. The Certificate number and year of issuance, the description of the property, and the names in which it was assessed are as follows:

CERTIFICATE NUMBER: 2018-17520

YEAR OF ISSUANCE: 2018

DESCRIPTION OF PROPERTY: LAKE NONA ESTATES PARCEL 12 66/98 LOT 36

PARCEL ID # 12-24-30-4936-00-360

Name in which assessed: GILBERTO PINHEIRO JR

ALL of said property being in the County of Orange, State of Florida. Unless such certificate shall be redeemed according to law, the property described in such certificate will be sold to the highest bidder online at www.orange.realtaxdeed.com scheduled to begin at 10:00 a.m. ET, Nov 05, 2020.

Dated: Sep 17, 2020
Phil Diamond
County Comptroller
Orange County, Florida
By: M Hildebrandt
Deputy Comptroller
Sep. 24; Oct. 1, 8, 15, 2020
20-03764W

FIRST INSERTION

NOTICE OF APPLICATION FOR TAX DEED

NOTICE IS HEREBY GIVEN that FIG FL18 LLC the holder of the following certificate has filed said certificate for a TAX DEED to be issued thereon. The Certificate number and year of issuance, the description of the property, and the names in which it was assessed are as follows:

CERTIFICATE NUMBER: 2018-19358

YEAR OF ISSUANCE: 2018

DESCRIPTION OF PROPERTY: BITHLO H/27 LOTS 26 THROUGH 29 BLK 410

PARCEL ID # 22-22-32-0712-80-260

Name in which assessed: SEAN M MCGUIRE

ALL of said property being in the County of Orange, State of Florida. Unless such certificate shall be redeemed according to law, the property described in such certificate will be sold to the highest bidder online at www.orange.realtaxdeed.com scheduled to begin at 10:00 a.m. ET, Nov 05, 2020.

Dated: Sep 17, 2020
Phil Diamond
County Comptroller
Orange County, Florida
By: M Hildebrandt
Deputy Comptroller
Sep. 24; Oct. 1, 8, 15, 2020
20-03770W

FIRST INSERTION

NOTICE OF APPLICATION FOR TAX DEED

NOTICE IS HEREBY GIVEN that FLORIDA TAX CERTIFICATE FUND 1 MUNICIPAL TAX LLC the holder of the following certificate has filed said certificate for a TAX DEED to be issued thereon. The Certificate number and year of issuance, the description of the property, and the names in which it was assessed are as follows:

CERTIFICATE NUMBER: 2018-16168

YEAR OF ISSUANCE: 2018

DESCRIPTION OF PROPERTY: CENTRE COURT CONDO 2 PHASE 4 CB 16/9 UNIT 808 BLDG 8

PARCEL ID # 04-23-30-1278-08-080

Name in which assessed: MICHAEL M PRIES

ALL of said property being in the County of Orange, State of Florida. Unless such certificate shall be redeemed according to law, the property described in such certificate will be sold to the highest bidder online at www.orange.realtaxdeed.com scheduled to begin at 10:00 a.m. ET, Nov 05, 2020.

Dated: Sep 17, 2020
Phil Diamond
County Comptroller
Orange County, Florida
By: M Hildebrandt
Deputy Comptroller
Sep. 24; Oct. 1, 8, 15, 2020
20-03759W

FIRST INSERTION

NOTICE OF APPLICATION FOR TAX DEED

NOTICE IS HEREBY GIVEN that FLORIDA TAX CERTIFICATE FUND 1 MUNICIPAL TAX LLC the holder of the following certificate has filed said certificate for a TAX DEED to be issued thereon. The Certificate number and year of issuance, the description of the property, and the names in which it was assessed are as follows:

CERTIFICATE NUMBER: 2018-18776

YEAR OF ISSUANCE: 2018

DESCRIPTION OF PROPERTY: NORTH SHORE AT LAKE HART PARCEL 3 PH 1 47/144 LOT 150

PARCEL ID # 16-24-31-5130-01-500

Name in which assessed: ADA CONTRERAS

ALL of said property being in the County of Orange, State of Florida. Unless such certificate shall be redeemed according to law, the property described in such certificate will be sold to the highest bidder online at www.orange.realtaxdeed.com scheduled to begin at 10:00 a.m. ET, Nov 05, 2020.

ORANGE COUNTY

FIRST INSERTION

NOTICE OF APPLICATION FOR TAX DEED
 NOTICE IS HEREBY GIVEN that FIG FL18 LLC the holder of the following certificate has filed said certificate for a TAX DEED to be issued thereon. The Certificate number and year of issuance, the description of the property, and the names in which it was assessed are as follows:

CERTIFICATE NUMBER:
2018-19396

YEAR OF ISSUANCE: 2018

DESCRIPTION OF PROPERTY:
BITHLO P/69 PARCEL 16 DESC AS S 75 FT OF N 330 FT OF W 105 FT OF BLK 2236 IN SEC 27-22-32 NE

PARCEL ID # 22-22-32-0728-23-603

Name in which assessed:
JAMES QUALLS, JUDITH QUALLS

ALL of said property being in the County of Orange, State of Florida. Unless such certificate shall be redeemed according to law, the property described in such certificate will be sold to the highest bidder online at www.orange.realtaxdeed.com scheduled to begin at 10:00 a.m. ET, Nov 05, 2020.

Dated: Sep 17, 2020
 Phil Diamond
 County Comptroller
 Orange County, Florida
 By: M Hildebrandt
 Deputy Comptroller
 Sep. 24; Oct. 1, 8, 15, 2020
 20-03772W

FIRST INSERTION

NOTICE TO CREDITORS IN THE CIRCUIT COURT FOR ORANGE COUNTY, FLORIDA PROBATE DIVISION
File No. 2020-CP-001556-O
Division 01
IN RE: ESTATE OF JACQUELINE GOMEZ A/K/A JACKIE GOMEZ Deceased.

The administration of the estate of Jacqueline Gomez a/k/a Jackie Gomez, deceased, whose date of death was September 27, 2019, is pending in the Circuit Court for Orange County, Florida, Probate Division, the address of which is 425 North Orange Avenue, Orlando, Florida 32801. The names and addresses of the personal representative and the personal representative's attorney are set forth below.

All creditors of the decedent and other persons having claims or demands against decedent's estate on whom a copy of this notice is required to be served must file their claims with this court ON OR BEFORE THE LATER OF 3 MONTHS AFTER THE TIME OF THE FIRST PUBLICATION OF THIS NOTICE OR 30 DAYS AFTER THE DATE OF SERVICE OF A COPY OF THIS NOTICE ON THEM.

All other creditors of the decedent and other persons having claims or demands against decedent's estate must file their claims with this court WITHIN 3 MONTHS AFTER THE DATE OF THE FIRST PUBLICATION OF THIS NOTICE.

ALL CLAIMS NOT FILED WITHIN THE TIME PERIODS SET FORTH IN FLORIDA STATUTES SECTION 733.702 WILL BE FOREVER BARRED.

NOTWITHSTANDING THE TIME PERIODS SET FORTH ABOVE, ANY CLAIM FILED TWO (2) YEARS OR MORE AFTER THE DECEDENT'S DATE OF DEATH IS BARRED.

The date of first publication of this notice is September 24, 2020.

Personal Representative:
Luz Yolanda Leseur
 6530 S. Goldenrod Rd., Unit C
 Orlando, FL 32822

Attorney for Personal Representative:
 Cyrus Malhotra, Esq.
 Florida Bar No. 0022751
 The Malhotra Law Firm
 3903 Northdale Boulevard, Suite 100E
 Tampa, Florida 33624
 Phone (813) 902-2119
 Fax (727) 290-4044
 E-Mail:
filings@flprobatesolutions.com
 Secondary E-Mail:
holly@flprobatesolutions.com
 Sep. 24; Oct. 1, 2020 20-03671W

FIRST INSERTION

NOTICE OF APPLICATION FOR TAX DEED
 NOTICE IS HEREBY GIVEN that FIG FL18 LLC the holder of the following certificate has filed said certificate for a TAX DEED to be issued thereon. The Certificate number and year of issuance, the description of the property, and the names in which it was assessed are as follows:

CERTIFICATE NUMBER:
2018-20013

YEAR OF ISSUANCE: 2018

DESCRIPTION OF PROPERTY:
CAPE ORLANDO ESTATES UNIT 12A 4/66 LOT 12 BLK 12

PARCEL ID # 10-23-32-1184-12-120

Name in which assessed: JANE E MURPHY, MARK R MURPHY, PETER J MURPHY

ALL of said property being in the County of Orange, State of Florida. Unless such certificate shall be redeemed according to law, the property described in such certificate will be sold to the highest bidder online at www.orange.realtaxdeed.com scheduled to begin at 10:00 a.m. ET, Nov 05, 2020.

Dated: Sep 17, 2020
 Phil Diamond
 County Comptroller
 Orange County, Florida
 By: M Hildebrandt
 Deputy Comptroller
 Sep. 24; Oct. 1, 8, 15, 2020
 20-03773W

FIRST INSERTION

NOTICE TO CREDITORS IN THE CIRCUIT COURT FOR ORANGE COUNTY, FLORIDA PROBATE DIVISION
File No. 2020-CP-002009-O
Division: Probate
IN RE: ESTATE OF WILLARD H. NORMAN, Deceased.

The administration of the estate of Willard H. Norman, deceased, whose date of death was April 15, 2019, is pending in the Circuit Court for Orange County, Florida, Probate Division, the address of which is 425 N. Orange Ave., Suite 355, Orlando, FL 32801. The names and addresses of the co-personal representatives and the co-personal representatives' attorney are set forth below.

All creditors of the decedent and other persons having claims or demands against decedent's estate on whom a copy of this notice is required to be served must file their claims with this court ON OR BEFORE THE LATER OF 3 MONTHS AFTER THE TIME OF THE FIRST PUBLICATION OF THIS NOTICE OR 30 DAYS AFTER THE DATE OF SERVICE OF A COPY OF THIS NOTICE ON THEM.

All other creditors of the decedent and other persons having claims or demands against decedent's estate must file their claims with this court WITHIN 3 MONTHS AFTER THE DATE OF THE FIRST PUBLICATION OF THIS NOTICE.

ALL CLAIMS NOT FILED WITHIN THE TIME PERIODS SET FORTH IN FLORIDA STATUTES SECTION 733.702 WILL BE FOREVER BARRED.

NOTWITHSTANDING THE TIME PERIODS SET FORTH ABOVE, ANY CLAIM FILED TWO (2) YEARS OR MORE AFTER THE DECEDENT'S DATE OF DEATH IS BARRED.

The date of first publication of this notice is September 24, 2020.

Co-Personal Representatives:
Cindy Morrison
 3 Deerwood
 Shoal Creek, AL 35242
Brenda Feliciani
 435 Sunglow Ct.
 Orlando, FL 32803

Attorney for Co-Personal Representatives:
 Natalie R. Wilson
 Florida Bar Number: 0027231
 GrayRobinson, P.A.
 One Lake Morton Dr.
 Lakeland, FL 33801
 Telephone: (863) 284-2200
 Fax: (863) 688-0310
 E-Mail:
natalie.wilson@gray-robinson.com
 Secondary E-Mail:
destiny.crisman@gray-robinson.com
 Sep. 24; Oct. 1, 2020 20-03672W

FIRST INSERTION

NOTICE OF APPLICATION FOR TAX DEED
 NOTICE IS HEREBY GIVEN that FIG FL18 LLC the holder of the following certificate has filed said certificate for a TAX DEED to be issued thereon. The Certificate number and year of issuance, the description of the property, and the names in which it was assessed are as follows:

CERTIFICATE NUMBER:
2018-20270

YEAR OF ISSUANCE: 2018

DESCRIPTION OF PROPERTY:
CAPE ORLANDO ESTATES UNIT 11A 3/107 LOT 28 BLK 3

PARCEL ID # 27-23-32-1181-03-280

Name in which assessed: YING-CHOU LUO

ALL of said property being in the County of Orange, State of Florida. Unless such certificate shall be redeemed according to law, the property described in such certificate will be sold to the highest bidder online at www.orange.realtaxdeed.com scheduled to begin at 10:00 a.m. ET, Nov 05, 2020.

Dated: Sep 17, 2020
 Phil Diamond
 County Comptroller
 Orange County, Florida
 By: M Hildebrandt
 Deputy Comptroller
 Sep. 24; Oct. 1, 8, 15, 2020
 20-03774W

FIRST INSERTION

NOTICE TO CREDITORS IN THE CIRCUIT COURT OF THE NINTH JUDICIAL CIRCUIT IN AND FOR ORANGE COUNTY, FLORIDA PROBATE DIVISION
FILE NO.: 2020-CP-002050-O
IN RE: THE ESTATE OF ALBERT P. SOYDEN, Deceased.

The administration of the Estate of Decedent, ALBERT P. SOYDEN ("Decedent"), whose date of death was July 27, 2020, and whose social security number is XXX-XX-1449, Case Number 2020-CP-002050-O, is pending in the Circuit Court for Orange County, Florida, Probate Division ("Circuit Court"), the address of which is 425 North Orange Avenue, Suite 355, Orlando, Florida 32801. The names and addresses of the Personal Representative and the Personal Representative's attorney are set forth below.

All creditors of Decedent and the other persons having claims or demands against Decedent's Estate on whom a copy of this Notice is required to be served must file their claims with this Circuit Court WITHIN THE LATER OF THREE MONTHS AFTER THE TIME OF THE FIRST PUBLICATION OF THIS NOTICE OR 30 DAYS AFTER THE DATE OF SERVICE OF A COPY OF THIS NOTICE ON THEM.

All other creditors of Decedent and the other persons having claims or demands against Decedent's Estate must file their claims with this court WITHIN THREE MONTHS AFTER THE DATE OF THE FIRST PUBLICATION OF THIS NOTICE.

ALL CLAIMS NOT FILED WITHIN THE TIME PERIODS SET FORTH IN SECTION 733.702 OF THE FLORIDA PROBATE CODE WILL BE FOREVER BARRED.

NOTWITHSTANDING THE TIME PERIODS SET FORTH ABOVE, ANY CLAIM FILED TWO (2) YEARS OR MORE AFTER THE DECEDENT'S DATE OF DEATH IS BARRED.

The date of the first publication of this Notice is September 24, 2020.

LISA S. VINING
Petitioner/
Personal Representative

ALAN J. BENT, ESQUIRE
 Florida Bar No.: 104893
 Sikes Law Group, PLLC
 310 South Dillard Street, Suite 120
 Winter Garden, FL 34787
 Primary Email:
abent@sikeslawgroup.com
rsikes@sikeslawgroup.com
rhassett@sikeslawgroup.com
 Secondary:
mrosales@sikeslawgroup.com
 Telephone: (407) 877-7115
 Facsimile: (407) 877-6970
 Attorneys for Petitioner, Lisa S. Vining
 Sep. 24; Oct. 1, 2020 20-03674W

FIRST INSERTION

NOTICE OF APPLICATION FOR TAX DEED
 NOTICE IS HEREBY GIVEN that LIEGE TAX LIENS LLC 18 the holder of the following certificate has filed said certificate for a TAX DEED to be issued thereon. The Certificate number and year of issuance, the description of the property, and the names in which it was assessed are as follows:

CERTIFICATE NUMBER:
2018-20285

YEAR OF ISSUANCE: 2018

DESCRIPTION OF PROPERTY:
CAPE ORLANDO ESTATES UNIT 11A 3/107 LOT 41 BLK 10

PARCEL ID # 27-23-32-1181-10-410

Name in which assessed: RADONDA DOBBINS

ALL of said property being in the County of Orange, State of Florida. Unless such certificate shall be redeemed according to law, the property described in such certificate will be sold to the highest bidder online at www.orange.realtaxdeed.com scheduled to begin at 10:00 a.m. ET, Nov 05, 2020.

Dated: Sep 17, 2020
 Phil Diamond
 County Comptroller
 Orange County, Florida
 By: M Hildebrandt
 Deputy Comptroller
 Sep. 24; Oct. 1, 8, 15, 2020
 20-03775W

FIRST INSERTION

NOTICE TO CREDITORS (Summary Administration) IN THE CIRCUIT COURT IN AND FOR ORANGE COUNTY, FLORIDA PROBATE DIVISION
File No. 2020-CP-001882-O
Division Probate
IN RE: ESTATE OF JANICE RAE BURGESS Deceased.

TO ALL PERSONS HAVING CLAIMS OR DEMANDS AGAINST THE ABOVE ESTATE:

You are hereby notified that an Order of Summary Administration has been entered in the estate of Janice Rae Burgess, deceased, File Number 2020-CP-001882-O, by the Circuit Court for Orange County, Florida, Probate Division, the address of which is 425 N. Orange Avenue, Rm 340, Orlando, FL 32801, that the decedent's date of death was May 8, 2020; that the total value of the estate is \$36,841.20 and that the names and addresses of those to whom it has been assigned by such order are:

Name Address
 Pamela Haber
 2603 Eagle Rock Lane
 Kissimmee, FL 34646
 Pamela Haber
 2603 Eagle Rock Lane
 Kissimmee, FL 34646

ALL INTERESTED PERSONS ARE NOTIFIED THAT:

All creditors of the estate of the Decedent and persons having claims or demands against the estate of the Decedent other than those for whom provision for full payment was made in the Order of Summary Administration must file their claims with this court WITHIN THE TIME PERIODS SET FORTH IN FLORIDA STATUTES SECTION 733.702. ALL CLAIMS AND DEMANDS NOT SO FILED WILL BE FOREVER BARRED. NOTWITHSTANDING ANY OTHER APPLICABLE TIME PERIOD, ANY CLAIM FILED TWO (2) YEARS OR MORE AFTER THE DECEDENT'S DATE OF DEATH IS BARRED.

The date of first publication of this Notice is September 24, 2020.

Person Giving Notice:
Pamela Haber
 2603 Eagle Rock Lane
 Kissimmee, Florida 34646

Attorney for Person Giving Notice
 Kristen M. Jackson
 Attorney for Pamela Haber
 Florida Bar Number: 394114
 JACKSON LAW PA
 5401 S KIRKMAN RD, Ste 310
 ORLANDO, FL 32819
 Telephone: (407) 363-9020
 Fax: (407) 363-9558
 E-Mail: jkackson@jacksonlawpa.com
 Secondary E-Mail:
jkackson@jacksonlawpa.com
 Sep. 24; Oct. 1, 2020 20-03788W

FIRST INSERTION

NOTICE OF APPLICATION FOR TAX DEED
 NOTICE IS HEREBY GIVEN that FIG FL18 LLC the holder of the following certificate has filed said certificate for a TAX DEED to be issued thereon. The Certificate number and year of issuance, the description of the property, and the names in which it was assessed are as follows:

CERTIFICATE NUMBER:
2018-20309

YEAR OF ISSUANCE: 2018

DESCRIPTION OF PROPERTY:
COWARD RANCHES 52/48 PT OF LOT 1 DESC AS BEG SE COR SAID LOT 1 TH RUN S89-51-48W 592.94 FT NWLY 334.11 FT N54-59-30W 94.26 FT N00-24-50E 731.28 FT N89-51-48E 985.11 FT TO E LINE SAID LOT 1 TH S00-25-06W 884.84 FT TO POB

PARCEL ID # 17-22-33-1492-00-010

Name in which assessed: WREN TIMBER AND CATTLE LLC

ALL of said property being in the County of Orange, State of Florida. Unless such certificate shall be redeemed according to law, the property described in such certificate will be sold to the highest bidder online at www.orange.realtaxdeed.com scheduled to begin at 10:00 a.m. ET, Nov 05, 2020.

Dated: Sep 17, 2020
 Phil Diamond
 County Comptroller
 Orange County, Florida
 By: M Hildebrandt
 Deputy Comptroller
 Sep. 24; Oct. 1, 8, 15, 2020
 20-03776W

FIRST INSERTION

NOTICE TO CREDITORS IN THE CIRCUIT COURT OF THE NINTH JUDICIAL CIRCUIT IN AND FOR ORANGE COUNTY, FLORIDA PROBATE DIVISION
FILE NO.: 2020-CP-002235-O
IN RE: THE ESTATE OF ADELA ELIAN MEIDA SOYDEN A/K/A ADELE E.M. SOYDEN, Deceased.

The administration of the Estate of Decedent, ADELA ELIAN MEIDA SOYDEN A/K/A ADELE E.M. SOYDEN ("Decedent"), whose date of death is October 19, 2019, and whose social security number is XXX-XX-7173, Case Number 2020-CP-002235-O, is pending in the Circuit Court for Orange County, Florida, Probate Division ("Circuit Court"), the address of which is 425 North Orange Avenue, Suite 355, Orlando, Florida 32801. The names and addresses of the Personal Representative and the Personal Representative's attorney are set forth below.

All creditors of Decedent and the other persons having claims or demands against Decedent's Estate on whom a copy of this Notice is required to be served must file their claims with this Circuit Court WITHIN THE LATER OF THREE MONTHS AFTER THE TIME OF THE FIRST PUBLICATION OF THIS NOTICE OR 30 DAYS AFTER THE DATE OF SERVICE OF A COPY OF THIS NOTICE ON THEM.

All other creditors of Decedent and the other persons having claims or demands against Decedent's Estate must file their claims with this court WITHIN THREE MONTHS AFTER THE DATE OF THE FIRST PUBLICATION OF THIS NOTICE.

ALL CLAIMS NOT FILED WITHIN THE TIME PERIODS SET FORTH IN SECTION 733.702 OF THE FLORIDA PROBATE CODE WILL BE FOREVER BARRED.

NOTWITHSTANDING THE TIME PERIODS SET FORTH ABOVE, ANY CLAIM FILED TWO (2) YEARS OR MORE AFTER THE DECEDENT'S DATE OF DEATH IS BARRED.

The date of the first publication of this Notice is September 24, 2020.

LISA S. VINING
Petitioner/
Personal Representative

ALAN J. BENT, ESQUIRE
 Florida Bar No.: 104893
 Sikes Law Group, PLLC
 310 South Dillard Street, Suite 120
 Winter Garden, FL 34787
 Primary Email:
abent@sikeslawgroup.com
rsikes@sikeslawgroup.com
rhassett@sikeslawgroup.com
 Secondary:
mrosales@sikeslawgroup.com
 Telephone: (407) 877-7115
 Facsimile: (407) 877-6970
 Attorneys for Petitioner, Lisa S. Vining
 Sep. 24; Oct. 1, 2020 20-03804W

FIRST INSERTION

NOTICE TO CREDITORS IN THE CIRCUIT COURT OF THE ORANGE JUDICIAL CIRCUIT IN AND FOR ORANGE COUNTY, FLORIDA PROBATE DIVISION
FILE NO.: 2020-CP-002348-O
DIVISION: 1
IN RE: ESTATE OF DE'ONTA K. JOHNSON, Deceased.

The administration of the Estate of De'onta K. Johnson, deceased, whose date of death was May 20, 2020, is pending in the Circuit Court for Orange County, Florida, Probate Division, the address of which is 425 North Orange Avenue, Orlando, FL 32801. The names and addresses of the personal representative and the personal representative's attorney are set forth below.

All creditors of the Decedent and other persons having claims or demands against Decedent's estate on whom a copy of this notice is required to be served must file their claims with this court WITHIN THE LATER OF 3 MONTHS AFTER THE TIME OF THE FIRST PUBLICATION OF THIS NOTICE OR 30 DAYS AFTER THE DATE OF SERVICE OF A COPY OF THIS NOTICE ON THEM.

All other creditors of the Decedent and other persons having claims or demands against Decedent's estate must file their claims with this court WITHIN 3 MONTHS AFTER THE DATE OF THE FIRST PUBLICATION OF THIS NOTICE.

ALL CLAIMS NOT FILED WITHIN THE TIME PERIODS SET FORTH IN SECTION 733.702 OF THE FLORIDA PROBATE CODE WILL BE FOREVER BARRED.

NOTWITHSTANDING THE TIME PERIODS SET FORTH ABOVE, ANY CLAIM FILED TWO (2) YEARS OR MORE AFTER THE DECEDENT'S DATE OF DEATH IS BARRED.

The date of first publication of this notice is September 24, 2020.

Personal Representative:
Thida Hall/
Personal Representative
c/o: Bennett Jacobs & Adams, P.A.

Post Office Box 3360
 Tampa, Florida 33601

Attorney for Personal Representative:
 Linda Muralt, Esquire
 Florida Bar No.: 0031129
 Bennett Jacobs & Adams, P.A.
 Post Office Box 3300
 Tampa, Florida 33601

Telephone: (813) 272-1400
 Facsimile: (866) 844-4703
 E-mail: LMuralt@bja-law.com
 Sep. 24; Oct. 1, 2020 20-03670W

FIRST INSERTION

NOTICE OF SALE UNDER F.S. CHAPTER 45 IN THE CIRCUIT COURT OF THE NINTH JUDICIAL CIRCUIT IN AND FOR ORANGE COUNTY, FLORIDA
CASE NO: 2015-CA-006271-O
U.S. BANK NATIONAL ASSOCIATION, AS TRUSTEE, ON BEHALF OF THE HOLDERS OF THE CSMC TRUST 2006-CF2 CS MORTGAGE PASS THROUGH CERTIFICATES, SERIES 2006-CF2, Plaintiff, v. MARK LAROCHE; ET. AL., Defendant(s).

NOTICE IS GIVEN that, in accordance with the Consent Final Judgment of Foreclosure dated June 8, 2020, and the Order on Plaintiff's Motion to Cancel and Reschedule Foreclosure Sale set for August 12, 2020 dated July 22, 2020, in the above-styled cause, the Clerk of Circuit Court Tiffany Moore Russell, shall sell the subject property at public sale on the 21st day of October 2020, at 11:00 a.m., to the highest and best bidder for cash, at www.orange.realforeclose.com for the following described property:

LOT 26, PINES OF WEKIVA SECTION 1, PHASE 2, TRACT B, ACCORDING TO THE PLAT THEREOF, RECORDED IN PLAT BOOK 36, PAGE 55 AND 56, OF THE PUBLIC RECORDS OF ORANGE COUNTY, FLORIDA.

Property address: 501 lancer oak drive, Orlando, FL 32712.

Any person claiming an interest in the surplus from the sale, if any, other than the property owner as of the date of the lis pendens must file a claim within 60 days after the sale.

Dated: September 17, 2020.

/s/ Ryan Marger
 Ryan Marger, Esquire
 Florida Bar No.: 44566
rmarger@bitman-law.com
svanegas@bitman-law.com

Attorneys for Plaintiff

BITMAN, O'BRIEN & MORAT, PLLC
 255 Primera Blvd., Suite 128
 Lake Mary, Florida 32746
 Telephone: (407) 815-3110
 Facsimile: (305) 697-2878
 Attorneys for Plaintiff
 Sep. 24; Oct. 1, 2020 20-03662W

FIRST INSERTION

NOTICE OF FORECLOSURE SALE PURSUANT TO CHAPTER 45 IN THE CIRCUIT COURT OF THE 9TH JUDICIAL CIRCUIT IN AND FOR ORANGE COUNTY, FLORIDA
CASE NO. 2020-CA-001332-O
LAKE DOE RESERVE HOMEOWNERS ASSOCIATION, INC., a Florida non-profit Corporation, Plaintiff, vs. CHRISTOPHER TIMMONS, et al, Defendant(s).
 NOTICE IS HEREBY GIVEN pursuant

to Order Granting Plaintiff's Motion to Reschedule Foreclosure Sale dated September 22, 2020 entered in Civil Case No.: 2020-CA-001332-O of the Circuit Court of the 9th Judicial Circuit in and for Orange County, Orlando, Florida, Foreclosure Sale will be held online via the Internet at www.myorangeclerk.realforeclose.com pursuant to Judgment or Order of the Court and Chapter 45, Florida Statutes, at 11:00 AM on the 26th day of October, 2020 the following described property as set forth in said Summary Final Judgment, to-wit:

LOT 34, LAKE DOE RESERVE PHASE 2, ACCORDING TO THE PLAT THEREOF AS RECORDED IN PLAT BOOK 83, PAGE 62, OF THE PUBLIC RECORDS OF ORANGE COUNTY, FLORIDA. More commonly known as: 300 SHEPPARD LAKE CT, APOPKA, FL 32703.
 ANY PERSON CLAIMING AN INTEREST IN THE SURPLUS FROM THE SALE, IF ANY, OTHER THAN THE PROPERTY OWNER AS OF THE DATE OF THE LIS PENDENS MUST FILE A CLAIM BEFORE THE

CLERK REPORTS THE SURPLUS AS UNCLAIMED.

Dated: September 22, 2020

/s/ Jared Block
 Jared Block, Esq.
 Fla. Bar No. 90297
 Email: Jared@flclg.com

Florida Community Law Group, P.L.
 Attorneys for Plaintiff
 1855 Griffin Road,
 Suite A-423
 Dania Beach, FL 33004
 Telephone (954) 372-5298
 Facsimile (866) 424-5348
 Sep. 24; Oct. 1, 2020 20-03783W

HOW TO PUBLISH YOUR LEGAL NOTICE IN THE BUSINESS OBSERVER

ORANGE COUNTY

FIRST INSERTION

NOTICE OF SALE
PURSUANT TO CHAPTER 45
IN THE CIRCUIT COURT OF THE
9TH JUDICIAL CIRCUIT IN AND
FOR ORANGE COUNTY, FLORIDA
CASE NO.: 2019-CA-013879-O

**U.S. BANK TRUST NATIONAL
ASSOCIATION AS TRUSTEE OF
THE LODGE SERIES III TRUST,
Plaintiff, v.
MICHAEL PRAIRIE; CYNTHIA I.
PRAIRIE; ET AL,
Defendants.**

NOTICE IS HEREBY GIVEN that pursuant to a Final Judgment in Foreclosure entered on September 14, 2020 and entered in Case No. 2019-CA-013879-O in the Circuit Court in and for Orange County, Florida, wherein U.S. BANK TRUST NATIONAL ASSOCIATION AS TRUSTEE OF THE LODGE SERIES III TRUST, is Plaintiff, and CYNTHIA I. PRAIRIE; MICHAEL PRAIRIE; AVALON PARK PROPERTY OWNERS ASSOCIATION, INC.; CITIMORTGAGE, INC.; DISCOVER BANK; UNKNOWN TENANT #1; UNKNOWN TENANT #2; UNKNOWN SPOUSE OF CYNTHIA I. PRAIRIE; UNKNOWN SPOUSE OF MICHAEL PRAIRIE are Defendants, The Clerk of the Court, Tiffany Moore Russell will sell to the highest and best bidder for cash at https://myorangeclerk.realforeclose.com on October 20, 2020 at 11:00 a.m., the following described property as set forth in said Final Judgment, to wit:

LOT 45, BLOCK A, AVALON PARK SOUTH PHASE 1, ACCORDING TO THE PLAT THEREOF AS RECORDED IN PLAT BOOK 52, PAGES 113 THRU 124, INCLUSIVE, PUBLIC RECORDS OF ORANGE COUNTY, FLORIDA.
and commonly known as: 14136 Bradbury Road, Orlando, FL

32828 (the "Property").
Any person claiming an interest in the surplus from the sale, if any, other than the property owner as of the date of the lis pendens must file a claim within sixty (60) days after the sale.

"IF YOU ARE A PERSON WITH A DISABILITY WHO NEEDS ANY ACCOMMODATION IN ORDER TO PARTICIPATE IN A COURT PROCEEDING OR EVENT, YOU ARE ENTITLED, AT NO COST TO YOU, TO THE PROVISION OF CERTAIN ASSISTANCE. PLEASE CONTACT: IN ORANGE COUNTY, ADA COORDINATOR, HUMAN RESOURCES, ORANGE COUNTY COURTHOUSE, 425 N. ORANGE AVENUE, SUITE 510, ORLANDO, FLORIDA, (407) 836-2303, FAX: 407-836-2204; AND IN OSCEOLA COUNTY: ADA COORDINATOR, COURT ADMINISTRATION, OSCEOLA COUNTY COURTHOUSE, 2 COURTHOUSE SQUARE, SUITE 6300, KISSIMMEE, FL 34741, (407) 742-2417, FAX 407-835-5079 AT LEAST 7 DAYS BEFORE YOUR SCHEDULED COURT APPEARANCE, OR IMMEDIATELY UPON RECEIVING NOTIFICATION IF THE TIME BEFORE THE SCHEDULED COURT APPEARANCE IS LESS THAN 7 DAYS. IF YOU ARE HEARING OR VOICE IMPAIRED, CALL 711 TO REACH THE TELECOMMUNICATIONS RELAY SERVICE."

By: /s/ Tara L. Rosenfeld
Chase A. Berger, Esq.
Florida Bar No.: 083794
Tara L. Rosenfeld, Esq.
Florida Bar No.: 0059454
fcplleadings@ghidotitberger.com
GHIDOTTI | BERGER LLP
Attorneys for Plaintiff
1031 North Miami Beach Blvd
North Miami Beach, FL 33162
Telephone: (305) 501.2808
Facsimile: (954) 780.5578
Sep. 24; Oct. 1, 2020 20-03729W

**NOTICE OF JUDICIAL
SALE BY THE CLERK
IN THE CIRCUIT COURT OF THE
ELEVENTH JUDICIAL CIRCUIT IN
AND FOR MIAMI-DADE
COUNTY, FLORIDA:
GENERAL JURISDICTION
DIVISION**

Civil Action No.: 19-030720-CA-01
Section: 10

**FFFI FORECLOSURE VEHICLE
137, LLC**

**Plaintiff (s) / Petitioner (s) vs.
ESPI 12600 SW 120 ST UNIT 3,
LLC; ET AL,
Defendant (s) / Respondent (s)**
NOTICE IS HEREBY GIVEN that pursuant to an Order or Final Judgment entered in the above styled cause now pending in said court, that I will sell to the highest and best bidder for cash on-line at www.MiamiDade.RealForeclose.com at 09:00 o'clock, AM on October 14, 2020 the following described property:

SEE ATTACHED LEGAL DESCRIPTION
The following real properties lying and being in Miami-Dade County, Florida:
PARCEL 1
Condominium Unit 9, SOUTH KENDALL SQUARE PROFESSIONAL CENTER, A CONDOMINIUM, according to the Declaration of Condominium thereof, as recorded in Official Records Book 23823, Page 4868, as amended from time to time, of the Public Records of Miami-Dade County, Florida; together with an undivided interest in the common elements appurtenant thereto.

PARCEL 2
Condominium Unit 10, SOUTH KENDALL SQUARE PROFESSIONAL CENTER, A CONDOMINIUM, according to the Declaration of Condominium thereof, as recorded in Official Records Book 23823, Page 4868, as amended from time to time, of the Public Records of Miami-Dade County, Florida; together with an undivided interest in the common elements appurtenant thereto.
PARCEL 3
Condominium Unit 11, SOUTH

KENDALL SQUARE PROFESSIONAL CENTER, A CONDOMINIUM, according to the Declaration of Condominium thereof, as recorded in Official Records Book 23823, Page 4868, as amended from time to time, of the Public Records of Miami-Dade County, Florida; together with an undivided interest in the common elements appurtenant thereto.

PARCEL 4
Unit No. 3 of ONE VILLAGE CONDOMINIUM, according to the Declaration of Condominium thereof, as recorded in Official Records Book 26306, Page 2098, as modified by that certain Certificate of Amendment to Declaration of Condominium recorded in Official Records Book 26358, Page 3607, of the Public Records of Miami-Dade County, Florida; together with an undivided share in the common elements appurtenant thereto.

The following real property lying and being in Palm Beach County, Florida:

PARCEL 5
Lot R 43 Unrecorded Subdivision of Rustic Ranches Phase II. A parcel of land in Section 13, Township 44 South, Range 40 East, Palm Beach County, Florida, being more particularly described as follows:
Commencing at the Southwest corner of said Section 13; thence run North 89 degrees 44 minutes 10 seconds East, along the South line of said Section 13, a distance of 689.45 feet to the POINT OF BEGINNING; thence continue North 89 degrees 44 minutes, 10 seconds East, along the South line, a distance of 319.80 feet; thence North 01 degrees 18 minutes 22 seconds East of said Section 13, a distance of 681.34 feet; thence South 89 degrees 44 minutes 03 seconds West, a distance of 319.80 feet; thence South 01 degrees 18 minutes 22 seconds West, a distance of 681.33 feet to the POINT OF BEGINNING.
SUBJECT TO the following Easements:
An Easement for ingress and egress, utilities and drainage

over the Northerly 27.73 feet thereof, and over the Westerly 25.57 feet thereof, as measured at right angles to the lot line; An Easement for utilities over the Easterly 6 feet thereof, as measured at right angles to the lot line; and an Easement for drainage over the Southerly 70 feet thereof, as measured at right angles to the lot line.

SUBJECT TO AND TOGETHER WITH an Easement for ingress and egress over the following:
A 60 foot strip of land lying in Section 13, Township 44 South, Range 40 East, Palm Beach County, Florida. Said strip of land lying 30 feet each side of, as measured at right angles to the following specifically described centerline.

Commencing at the Northeast corner of said Section 13; thence run South 89 degrees 43 minutes 57 seconds West, along the North line of said Section 13, a distance of 30.01 feet to the POINT OF BEGINNING; thence South 01 degrees 18 minutes 22 seconds West, parallel with and 30 feet Westerly of, as measured at right angles to the East line of said Section 13, a distance of 3336.25 feet; thence South 89 degrees 44 minutes 03 seconds West, a distance of 4571.27 feet; thence North 00 degrees 12 minutes 30 seconds West, a distance of 697.22 feet; thence South 01 degrees 18 minutes 22 seconds West, a distance of 1258.11 feet; thence North 89 degrees 44 minutes 03 seconds East, a distance of 10.00 feet; thence South 01 degrees 18 minutes 22 seconds West, a distance of 683.60 feet; thence North 89 degrees 44 minutes 03 seconds East, a distance of 4561.39 feet to a point in a line, parallel with and 30 feet Westerly of the East line of said Section 13; thence South 01 degrees 17 minutes 49 seconds West, along said parallel line, a distance of 683.75 feet; thence North 01 degrees 17

minutes 49 seconds East, along said parallel line, a distance of 683.75 feet; thence continue North 01 degrees 17 minutes 49 seconds East, along said parallel line a distance of 703.48 feet to a point; thence North 01 degrees 18 minutes 22 seconds East, along a line parallel with and 30 feet Westerly of, as measured at right angles to the East line of said Section 13, a distance of 554.63 feet to the end of said specifically described centerline.
The following real properties lying and being in Orange County, Florida :

PARCEL 6
Condominium Unit No. 3, Building 17, of The Estates at Park Central Condominium, a Condominium, according to the Declaration of Condominium thereof, as recorded in Official Records Book 8662, Page 3767, Public Records of Orange County, Florida, and all recorded and unrecorded amendments thereto. Together with an undivided interest or share in the common elements appurtenant thereto.

PARCEL 7
Unit 4, Building 17, of The Estate at Park Central Condominium, a Condominium, according to the Declaration of Condominium thereof, as recorded in Official Records Book 8662, Page 3767, Public Records of Orange County, Florida, and all recorded and unrecorded amendments thereto. Together with an undivided interest or share in the common elements appurtenant thereto.

ANY PERSON CLAIMING AN INTEREST IN THE SURPLUS FROM THE SALE, IF ANY, OTHER THAN THE PROPERTY OWNER AS OF THE DATE OF THE LIS PENDENS MUST FILE A CLAIM WITHIN 60 DAYS AFTER THE SALE.

WITNESS my hand and the seal of this court on September 16, 2020.

By: Ververy Lewis-James,
Deputy Clerk

/s/ Harvey Ruvin
Harvey Ruvin,
Clerk Miami-Dade County, Florida
Law Firm:
MORGAN, OLSEN & OLSEN, LLP
Sep. 24; Oct. 1, 2020 20-03666W

FIRST INSERTION

NOTICE OF FORECLOSURE SALE
IN THE CIRCUIT COURT OF THE
NINTH JUDICIAL CIRCUIT, IN
AND FOR ORANGE COUNTY,
FLORIDA.

**CASE No. 2018-CA-005900-O
REVERSE MORTGAGE
SOLUTIONS, INC.,
PLAINTIFF, VS.**

**THE UNKNOWN HEIRS,
BENEFICIARIES, DEVISEES,
GRANTEES, ASSIGNORS,
CREDITORS AND TRUSTEES
OF THE ESTATE OF MARIA
RODRIGUEZ A/K/A MARIA
ANTONIETA RODRIGUEZ,
DECEASED, ET AL.
DEFENDANT(S).**

NOTICE IS HEREBY GIVEN pursuant to the Final Judgment of Foreclosure dated February 20, 2020 in the above action, the Orange County Clerk of Court will sell to the highest bidder for cash at Orange, Florida, on January 11, 2021, at 11:00 AM, at www.myorangeclerk.realforeclose.com in accordance with Chapter 45, Florida Statutes for the following described property:

Condominium Unit 3-1C PALOMAR PLACE, A CONDOMINIUM, according to the Declaration of Condominium thereof, as Recorded in OR Book 2147, at Page 498, together with a survey and plot plan recorded in Condominium Exhibit Book 7, Page 60, all in the Public Records of Orange County, Florida, and further amendments, if any, to said Declaration and amendments therein hereafter collectively referred to as the declaration,

together with all appurtenances thereto, including an undivided interest in the common elements appertaining to the unit, as more particularly set forth in the Declaration

Any person claiming an interest in the surplus from the sale, if any, other than the property owner as of the date of the lis pendens must file a claim before the clerk reports the surplus as unclaimed. The Court, in its discretion, may enlarge the time of the sale. Notice of the changed time of sale shall be published as provided herein.

If you are a person with a disability who needs any accommodation in order to participate in this proceeding, you are entitled, at no cost to you, to the provision of certain assistance. Please contact ADA Coordinator Orange County, Human Resources at 407-836-2303, fax 407-836-2204 or at ctadmd2@ocnjcc.org, Orange County Courthouse, 425 N. Orange Avenue, Suite 510, Orlando, FL 32810 at least 7 days before your scheduled court appearance, or immediately upon receiving this notification if the time before the scheduled appearance is less than 7 days; if you are hearing or voice impaired, call 711.

By: Marlon Hyatt, Esq.
FBN 72009
Tromberg Law Group
Attorney for Plaintiff
1515 South Federal Highway, Suite 100
Boca Raton, FL 33432
Telephone #: 561-338-4101
Fax #: 561-338-4077
Email:
eservice@tromberglawgroup.com
Our Case #: 18-000579-FNMA-REV
Sep. 24; Oct. 1, 2020 20-03668W

NOTICE OF ONLINE SALE
IN THE CIRCUIT COURT OF THE
NINTH JUDICIAL CIRCUIT IN AND
FOR ORANGE COUNTY, FLORIDA
CIVIL DIVISION

**CASE NO. 2019-CA-8900-O
HARVEY SCHONBRUN, AS
TRUSTEE,
Plaintiff, vs.
WICHIT CHANTHARATH and
THE HAMLET AT MAITLAND
HOMEOWNERS ASSOCIATION,
INC.,
Defendants.**

Notice is hereby given that, pursuant to a Summary Final Judgment of Foreclosure and an Order Granting Motion to Reset Foreclosure Sale entered in the above styled cause, in the Circuit Court of Orange County, Florida, the Office of Tiffany Moore Russell, Clerk of the Circuit Court, will sell the property situate in Orange County, Florida, described as:

Lot 7, THE HAMLET AT MAITLAND, according to the map or plat thereof, as recorded in Plat Book 31, Page 17, of the Public Records of Orange County, Florida.

at public sale, to the highest and best

FIRST INSERTION

bidder, for cash, on October 26, 2020 at 11:00 a.m. at www.myorangeclerk.realforeclose.com in accordance with Chapter 45 Florida Statutes.
Any person claiming an interest in the surplus from the sale, if any, other than the property owner as of the date of the lis pendens, must file a claim within 60 days after the sale.
Dated: September 22, 2020.
Harvey Schonbrun, Esquire
HARVEY SCHONBRUN, P. A.
1802 North Morgan Street
Tampa, Florida 33602-2328
813/229-0664 phone
Sep. 24; Oct. 1, 2020 20-03790W

FIRST INSERTION

TRUSTEE FOR TRUMAN 2016 SC6 TITLE TRUST is Plaintiff and EDWARD ROBERTS, STATE OF FLORIDA; CLERK OF COURT IN AND FOR ORANGE COUNTY, FLORIDA; ORANGE COUNTY, A POLITICAL SUBDIVISION OF THE STATE OF FLORIDA; UNKNOWN SPOUSE OF EDWARD ROBERTS; UNKNOWN SPOUSE OF DIANA ROBERTS A/K/A DIANA K. ROBERTS; UNKNOWN TENANT# 1; UNKNOWN TENANT NO. 2; and ALL UNKNOWN PARTIES CLAIMING INTERESTS BY, THROUGH, UNDER OR AGAINST A NAMED DEFENDANT TO THIS ACTION, OR HAVING OR CLAIMING TO HAVE ANY RIGHT, TITLE OR INTEREST IN THE PROPERTY HEREIN DESCRIBED, are Defendants, TIFFANY MOORE RUSSELL, Clerk of the Circuit Court, will sell to the highest and best bidder for cash www.myorangeclerk.realforeclose.com, 11:00 A.M., on October 29, 2020, the following described property as set forth in said Order or Final Judgment, to-wit:

LOT 9 AND 10, BLOCK B, COOPER AND SEWELL'S ADDITION TO WINTER GARDEN, ACCORDING TO THE PLAT THEREOF AS RECORDED IN PLAT BOOK F, PAGE 39, PUBLIC RECORDS OF ORANGE COUNTY, FLORIDA.

ANY PERSON CLAIMING AN INTEREST IN THE SURPLUS FROM THE SALE, IF ANY, OTHER THAN THE PROPERTY OWNER AS OF THE DATE OF THE LIS PENDENS

FIRST INSERTION

NOTICE OF ONLINE SALE
IN THE CIRCUIT COURT OF THE
NINTH JUDICIAL CIRCUIT, IN AND FOR
ORANGE COUNTY, FLORIDA
**CASE NO.: 2019-CA-009268-O
NEWREZ LLC, F/K/A NEW
PENN FINANCIAL, LLC, D/B/A
SHELLPOINT MORTGAGE
SERVICING,
Plaintiff, vs.
UNKNOWN SPOUSE, HEIRS,
BENEFICIARIES, DEVISEES,
ASSIGNEES, LIENORS,
CREDITORS, TRUSTEES, ALL
OTHERS WHO MAY CLAIM AND
INTEREST IN THE ESTATE OF
DAVID HELMES; et al.,
Defendants.**

NOTICE IS GIVEN that, in accordance with the Order on Plaintiff's Motion to Reschedule Foreclosure Sale entered on August 21, 2020 in the above-styled cause, Tiffany Moore Russell, Orange County clerk of court shall sell to the highest and best bidder for cash on October 20, 2020 at 11:00 A.M., at www.myorangeclerk.realforeclose.com, the following described property:

LOT 6, SECOND REPLAT OF A PORTION OF BLOCK B, WASHINGTON SHORES SUBDIVISION, ACCORDING TO THE PLAT THEREOF, RECORDED IN PLAT BOOK R, PAGE 101, PUBLIC RECORDS OF ORANGE COUNTY, FLORIDA.
Property Address: 3405 Lewis Court, Orlando, FL 32805
ANY PERSON CLAIMING AN INTEREST IN THE SURPLUS FROM THE SALE, IF ANY, OTHER THAN THE PROPERTY OWNER AS OF THE DATE OF THE LIS PENDENS MUST FILE A CLAIM BEFORE THE CLERK REPORTS THE SURPLUS AS UNCLAIMED

AMERICANS WITH DISABILITIES ACT
If you are a person with a disability who needs any accommodation in order to participate in this proceeding, you are entitled, at no cost to you, to the provision of certain assistance. Please contact the ADA Coordinator, Human Resources, Orange County Courthouse, 425 N. Orange Avenue, Suite 510, Orlando, Florida, (407) 836-2303, at least 7 days before your scheduled court appearance, or immediately upon receiving this notification if the time before the scheduled appearance is less than 7 days; if you are hearing or voice impaired, call 711.

Pursuant to Florida Statute 45.031(2), this notice shall be published twice, once a week for two consecutive weeks, with the last publication being at least 5 days prior to the sale.
DATED 9/18/2020.
By: /s/ Nazish Z. Shah
Nazish Z. Shah
Florida Bar No.: 92172
Roy Diaz, Attorney of Record
Florida Bar No. 767700
Diaz Anselmo Lindberg, P.A.
Attorneys for Plaintiff
499 NW 70th Ave., Suite 309
Fort Lauderdale, FL 33317
Telephone: (954) 564-0071
Facsimile: (954) 564-9252
Service E-mail: answers@dallegal.com
1460-166141 / VMR
Sep. 24; Oct. 1, 2020 20-03664W

FIRST INSERTION

NOTICE OF RESCHEDULED SALE
PURSUANT TO CHAPTER 45
IN THE CIRCUIT COURT OF THE
NINTH JUDICIAL CIRCUIT IN AND
FOR ORANGE COUNTY, FLORIDA
CIVIL ACTION

**CASE NO.: 48-2017-CA-006328-O
DIVISION: 33**

**LAKEVIEW LOAN SERVICING,
LLC,
Plaintiff, vs.
FELICIA BAKER, et al,
Defendant(s).**

NOTICE IS HEREBY GIVEN Pursuant to an Order Rescheduling Foreclosure Sale dated August 20, 2020, and entered in Case No. 48-2017CA-006328-O of the Circuit Court of the Ninth Judicial Circuit in and for Orange County, Florida in which Lakeview Loan Servicing, LLC, is the Plaintiff and Felicia Baker, Sandon Baker a/k/a Sandon J. Baker, Admiral Pointe Homeowners Association, Inc., Dick Joyce Well Drilling, Inc., United States of America Acting through Secretary of Housing and Urban Development, are defendants, the Orange County Clerk of the Circuit Court will sell to the highest and best bidder for cash in/on online at www.myorangeclerk.realforeclose.com, Orange County, Florida at 11:00am on the October 13, 2020 the following described property as set forth in said Final Judgment of Foreclosure:

LOT 100, ADMIRAL POINTE, ACCORDING TO THE PLAT THEREOF, AS RECORDED IN

PLAT BOOK 35, PAGES 40-42, OF THE PUBLIC RECORDS OF ORANGE COUNTY, FLORIDA.
A/K/A 171 BISMARCK COURT, OCOEE, FL 34761

Any person claiming an interest in the surplus from the sale, if any, other than the property owner as of the date of the Lis Pendens must file a claim before the Clerk reports the surplus as unclaimed.

If you are a person with a disability who needs any accommodation in order to participate in this proceeding, you are entitled, at no cost to you, to the provision of certain assistance. Please contact the ADA Coordinator, Human Resources, Orange County Courthouse, 425 N. Orange Avenue, Suite 510, Orlando, Florida, (407) 836-2303, at least 7 days before your scheduled court appearance, or immediately upon receiving this notification if the time before the scheduled appearance is less than 7 days; if you are hearing or voice impaired, call 711.

Dated this 15 day of September, 2020.
By: /s/ Charline Calhoun
Florida Bar #16141

ALBERTELLI LAW
P. O. Box 23028
Tampa, FL 33623
Tel: (813) 221-4743
Fax: (813) 221-9171
eService:
servealaw@albertellilaw.com
CT - 16-034598
Sep. 24; Oct. 1, 2020 20-03661W

SAVE TIME - EMAIL YOUR LEGAL NOTICES

Sarasota County • Manatee County • Hillsborough County • Charlotte County
Pinellas County • Pasco County • Polk County • Lee County
Collier County • Orange County
legal@businessobserverfl.com

Wednesday 2pm Deadline for Friday Publication | Wednesday 10am for Thursday Publication in Orange County



Quintairos, Prieto, Wood & Boyer, P.A.
255 S. Orange Ave., Ste. 900
Orlando, FL 32801-3454
(855) 287-0240
(855) 287-0211 Facsimile
E-mail: servicecopies@qpwbaw.com
E-mail: mdeleon@qpwbaw.com
Matter # 124603
Sep. 24; Oct. 1, 2020 20-03667W

ORANGE COUNTY

FIRST INSERTION

NOTICE OF ACTION - CONSTRUCTIVE SERVICE IN THE CIRCUIT COURT OF THE NINTH JUDICIAL CIRCUIT IN AND FOR ORANGE COUNTY, FLORIDA GENERAL JURISDICTION DIVISION

Case No. 482018CA009975A0010X Wells Fargo Bank, N.A. successor by merger to Wachovia Bank, N.A. Plaintiff, vs. Abdul Aziz Al-Ghanaam Ali-Mohamad; et al. Defendants.
TO: The Unknown Spouse, Heirs, Devisees, Grantees, Assignees, Lienors, Creditors, Trustees, and all other parties claiming interest by, through, under or against the Estate of Abdul Aziz Ali-Mohamad Al-Ghanaam, Deceased, Dr. Bareeq Abdulaziz Ali Ghannam a/k/a Dr. Barik Abdul Aziz Ali Al-Ghannan A/K/A Bareeq A A M Alghannam and Mrs. Bara Abdulaziz Ali AlGhannam a/k/a Mrs. Baraa Abdulaziz Ali Al-Ghannam A/K/A Bara A A M Alghannam
Last Known Address: Unknown
YOU ARE HEREBY NOTIFIED that an action to foreclose a mortgage on the following property in Orange County, Florida:

LOT 4, BLOCK 181, WILLOW-BROOK PHASE 2, ACCORDING TO THE PLAT THEREOF AS RECORDED IN PLAT BOOK 29, PAGES 105-106, PUBLIC RECORDS OF ORANGE-COUNTY, FLORIDA
has been filed against you and you are required to serve a copy of your written defenses, if any, to it on Julie Anthonis, Esquire, Brock & Scott, PLLC., the Plaintiff's attorney, whose address is 2001 NW 64th St, Suite 130 Ft. Lauderdale, FL 33309, within thirty (30) days of the first date of publication on or before XXXXXXXXXXXXXXXX, and file the original with the Clerk of this Court either before service on the Plaintiff's attorney or immediately thereafter; otherwise a default will be entered against you for the relief demanded in the complaint or petition.
Tiffany Russell
As Clerk of the Court
By Grace Katherine Uy, Deputy Clerk
2020-09-17 09:11:39
As Deputy Clerk
425 North Orange Ave.
Suite 350
Orlando, Florida 32801
File# 18-F01923
Sep. 24; Oct. 1, 2020 20-03663W

FIRST INSERTION

NOTICE OF SALE IN THE COUNTY COURT OF ORANGE COUNTY, FLORIDA
CASE NO: 2020-CC-1858-O LA JOYA COVE ASSOCIATION INC., a Florida not for profit Corporation Plaintiff, vs. MICHAEL DOUGLAS; NICOLE RIVIERE Defendants
NOTICE IS HEREBY GIVEN pursuant to a Final Judgment of the Court dated August 20, 2020 and entered in Case No: 2020-CC-1858-O of the County Court in and for Orange County, Florida, wherein LA JOYA COVE ASSOCIATION, INC., is the Plaintiff and MICHAEL DOUGLAS; NICOLE RIVIERE, the Defendants, I will sell to the highest and best bidder for cash, www.myorangeclerk.realforeclose.com the Clerk's Website for on-line auctions at 11:00 A.M. on October 27, 2020, the following described real property as set forth in the Order of Final Judgment, to wit:
Lot 28, La Joya Cove, according to the Plat thereof recorded in Plat Book 31, Page 14 of the Public Records of Orange County, Florida.
This property is located at the street address of: 4862 Robbins Avenue, Orlando, FL 32808
Any person claiming an interest in the surplus funds from the sale, if any, other than the property owners as of the lis pendens must file a claim before the

Clerk reports the surplus as unclaimed.
The Ninth Judicial Circuit is committed to full compliance with the Americans with Disabilities Act (ADA). Reasonable accommodations are provided for qualified court participants with disabilities, in accordance with the law. As required by the ADA, the determination of an individual's disability and the option for a reasonable accommodation for a disability is made on a case-by-case basis. If you are a person with a disability who needs any accommodation in order to participate in a court proceeding or event, you are entitled, at no cost to you, to the provision of certain assistance.
Please contact us as follows at least 7 days before your scheduled court appearance, or immediately if you receive less than a 7-day notice to appear: Orange County ADA Coordinator, Human Resources, Orange County Courthouse, 425 N. Orange Avenue, Suite 510, Orlando, Florida, (407) 836-2303, fax: 407-836-2204
DATED at Palm Beach County, Florida this 14th Day of September 2020.
By: /s/ DAVID Y. KLEIN
David Y. Klein
Fla. Bar. No. 44363
Dklein@milbergkleinlaw.com
MILBERG KLEIN, P.L.
5550 Glades Road, Suite 500
Boca Raton, FL 33431
Phone: (561) 244-9461
Fax: (561) 245-9465
Sep. 24; Oct. 1, 2020 20-03786W

FIRST INSERTION

NOTICE OF FORECLOSURE SALE IN THE CIRCUIT COURT OF THE NINTH JUDICIAL CIRCUIT IN AND FOR ORANGE COUNTY, FLORIDA GENERAL JURISDICTION DIVISION
CASE NO. 2017-CA-003626-O U.S. BANK NATIONAL ASSOCIATION, AS TRUSTEE FOR RESIDENTIAL ASSET SECURITIES CORPORATION, HOME EQUITY MORTGAGE ASSET-BACKED PASS-THROUGH CERTIFICATES, SERIES 2006-KS2, Plaintiff, vs. TINA MONTANO A/K/A TINA M. MONTANA AND DAVID L. COON A/K/A DAVID COON, et al. Defendant(s).
NOTICE IS HEREBY GIVEN pursuant to a Final Judgment of Foreclosure dated July 18, 2018, and entered in 2017-CA-003626-O of the Circuit Court of the NINTH Judicial Circuit in and for Orange County, Florida, wherein U.S. BANK NATIONAL ASSOCIATION, AS TRUSTEE FOR RESIDENTIAL ASSET SECURITIES CORPORATION, HOME EQUITY MORTGAGE ASSET-BACKED PASS-THROUGH CERTIFICATES, SERIES 2006-KS2 is the Plaintiff and TINA MONTANO A/K/A TINA M. MONTANO; DAVID L. COON A/K/A DAVID COON; RICKEY L. PIGUE; DEBBIE K. PIGUE; FLORIDA HOUSING FINANCE CORPORATION; ONE-MAIN FINANCIAL OF AMERICA, INC. F/K/A SPRINGLEAF FINANCIAL SERVICES OF AMERICA, INC.; LVNV FUNDING LLC; ARROW FINANCIAL SERVICES, LLC AS ASSIGNEE OF GE MONEY BANK; CAPITAL ONE BANK (USA), N.A.; STATE OF FLORIDA, DEPARTMENT OF REVENUE; CLERK OF THE COURTS IN AND FOR ORANGE COUNTY, FLORIDA; TIME INVESTMENT COMPANY are the Defendant(s). Tiffany Moore Russell as the Clerk of the Circuit Court will sell to the highest and best bidder for cash at www.myorangeclerk.realforeclose.com, at 11:00 AM, on October 14, 2020, the following described property as set forth in said Final Judgment, to wit:

LOT 11, BLOCK 7, OF REPLAT OF PORTIONS OF MT. PLYMOUTH LAKES, ACCORDING TO THE PLAT THEREOF AS RECORDED IN PLAT BOOK X, PAGES 29 AND 30, OF THE PUBLIC RECORDS OF ORANGE COUNTY, FLORIDA.
Property Address: 635 DISNEY DR, APOPKA, FL 32712
Any person claiming an interest in the surplus from the sale, if any, other than the property owner as of the date of the lis pendens must file a claim in accordance with Florida Statutes, Section 45.031.
IMPORTANT AMERICANS WITH DISABILITIES ACT. If you are a person with a disability who needs any accommodation in order to participate in a court proceeding or event, you are entitled, at no cost to you, to the provision of certain assistance. Please contact Orange County, ADA Coordinator, Human Resources, Orange County Courthouse, 425 N. Orange Avenue, Suite 510, Orlando, Florida, (407) 836-2303, fax: 407-836-2204; and in Osceola County: ADA Coordinator, Court Administration, Osceola County Courthouse, 2 Courthouse Square, Suite 6300, Kissimmee, FL 34741, (407) 742-2417, fax 407-835-5079, at least 7 days before your scheduled court appearance, or immediately upon receiving notification if the time before the scheduled court appearance is less than 7 days. If you are hearing or voice impaired, call 711 to reach the Telecommunications Relay Service.
Dated this 16 day of September, 2020.
By: \S\Tiffanie Waldman
Tiffanie Waldman, Esquire
Florida Bar No. 86591
Communication Email: twaldman@rasflaw.com
ROBERTSON, ANSCHUTZ & SCHNEID, P.L.
Attorney for Plaintiff
6409 Congress Ave.,
Suite 100
Boca Raton, FL 33487
Telephone: 561-241-6901
Facsimile: 561-997-6909
Service Email: mail@rasflaw.com
16-225773 - MaS
Sep. 24; Oct. 1, 2020 20-03732W

FIRST INSERTION

NOTICE OF FORECLOSURE SALE IN THE CIRCUIT COURT FOR THE NINTH JUDICIAL CIRCUIT IN AND FOR ORANGE COUNTY, FLORIDA
CIRCUIT CIVIL DIVISION
CASE NO.: 2019-CA-001399-O WILMINGTON SAVINGS FUND SOCIETY, FSB, DBA CHRISTIANA TRUST, NOT INDIVIDUALLY BUT AS TRUSTEE FOR PRETIUM MORTGAGE ACQUISITION TRUST Plaintiff(s), vs. SHAWN J. REBEYKA, et al.; Defendant(s).
NOTICE IS HEREBY GIVEN THAT, pursuant to Plaintiff's Final Judgment of Foreclosure entered on August 19, 2020 in the above-captioned action, the Clerk of Court, Tiffany Moore Russell, will sell to the highest and best bidder for cash at www.myorangeclerk.realforeclose.com in accordance with Chapter 45, Florida Statutes on the 26th day of October, 2020 at 11:00 AM on the following described property as set forth in said Final Judgment of Foreclosure or order, to wit:
Lot 17, of Summerport, Phase 1, according to the Plat thereof, as recorded in Plat Book 53, at Pages 1 through 8, inclusive, of the Public Records of Orange County, Florida.
Property address: 13844 Amelia Pond Drive, Windermere, FL 34786
Any person claiming an interest in the surplus from the sale, if any, other than the property owner as of the date of the lis pendens, must file a claim before the clerk reports the surplus as unclaimed.
AMERICANS WITH DISABILITIES ACT. IF YOU ARE A PERSON WITH A DISABILITY WHO NEEDS ANY ACCOMMODATION IN ORDER TO PARTICIPATE IN A COURT PROCEEDING OR EVENT, YOU ARE ENTITLED, AT NO COST TO YOU, TO THE PROVISION OF CERTAIN ASSISTANCE. PLEASE CONTACT: ADA COORDINATOR, HUMAN RESOURCES, ORANGE COUNTY COURTHOUSE, 425 N. ORANGE AVENUE, SUITE 510, ORLANDO, FLORIDA, (407) 836-2303, FAX: 407-836-2204; AT LEAST 7 DAYS BEFORE YOUR SCHEDULED COURT APPEARANCE, OR IMMEDIATELY UPON RECEIVING NOTIFICATION IF THE TIME BEFORE THE SCHEDULED COURT APPEARANCE IS LESS THAN 7 DAYS. IF YOU ARE HEARING OR VOICE IM-

PAIRED, CALL 711 TO REACH THE TELECOMMUNICATIONS RELAY SERVICE.
Pursuant to the Fla. R. Jud. Admin. 2.516, the above signed counsel for Plaintiff designates attorney@padgett-lawgroup.com as its primary e-mail address for service, in the above styled matter, of all pleadings and documents required to be served on the parties.
Respectfully submitted,
DAVID R. BYARS, ESQ.
Florida Bar # 114051
PADGETT LAW GROUP
6267 Old Water Oak Road,
Suite 203
Tallahassee, FL 32312
(850) 422-2520 (telephone)
(850) 422-2567 (facsimile)
attorney@padgettlawgroup.com
Attorney for Plaintiff
TDP File No. 18-001468-1
Sep. 24; Oct. 1, 2020 20-03784W

FIRST INSERTION

NOTICE OF FORECLOSURE SALE IN THE CIRCUIT COURT OF THE 9TH JUDICIAL CIRCUIT IN AND FOR ORANGE COUNTY, FLORIDA
CASE NO.: 2019-CA-000034-O FIRST EQUITY MORTGAGE BANKERS, INC., Plaintiff, v. THE UNKNOWN HEIRS, DEVISEES, GRANTEEES, ASSIGNEES, CREDITORS, LIENORS AND TRUSTEES OF WILLIE C. GILBERT, ET AL., Defendants.
NOTICE IS HEREBY GIVEN pursuant to a Final Judgment dated September 21, 2020 entered in Civil Case No. 2019-CA-000034-O in the Circuit Court of the Ninth Judicial Circuit in and for Orange County, Florida, wherein FIRST EQUITY MORTGAGE BANKERS, INC., Plaintiff and THE UNKNOWN HEIRS, DEVISEES, GRANTEEES, ASSIGNEES, CREDITORS, LIENORS AND TRUSTEES OF WILLIE C. GILBERT; CYNTHIA TRIM GILBERT; ALL UNKNOWN PARTIES CLAIMING INTERESTS BY, THROUGH, UNDER OR AGAINST A NAMED DEFENDANT TO THIS ACTION, OR HAVING OR CLAIMING TO HAVE ANY RIGHT, TITLE OR INTEREST IN THE PROPERTY HEREIN DESCRIBED; ORLANDO HEALTH, INC.; ORANGE COUNTY, FLORIDA; F.A. MANAGEMENT SOLUTIONS, INC.; TYEESSE BARNES; JESSIE REE HORN; WILLIE C. GILBERT, JR., are defendants, Clerk of Court, will sell the property at public sale at www.myorangeclerk.realforeclose.com beginning at 11:00 AM on November 3, 2020 the following described property as set forth in said Final Judgment, to-wit:
LOT 5, BLOCK 1, TANGELO PARK SECTION ONE, ACCORDING TO THE PLAT THEREOF AS RECORDED IN PLAT BOOK W, PAGE 100, OF THE PUBLIC RECORDS OF ORANGE COUNTY, FLORIDA.
Property Address: 7727 Nectar Drive, Orlando, FL 32819
ANY PERSON CLAIMING AN INTEREST IN THE SURPLUS FROM THE SALE, IF ANY, OTHER THAN THE PROPERTY OWNER AS OF THE DATE OF THE LIS PENDENS MUST FILE A CLAIM BEFORE THE CLERK REPORTS THE SURPLUS AS UNCLAIMED.
THE COURT, IN ITS DISCRETION, MAY ENLARGE THE TIME OF THE SALE. NOTICE OF THE CHANGED TIME OF SALE SHALL BE PUBLISHED AS PROVIDED HEREIN.
IF YOU ARE A PERSON WITH A DISABILITY WHO NEEDS ANY ACCOMMODATION IN ORDER TO PARTICIPATE IN A COURT PROCEEDING OR EVENT, YOU ARE ENTITLED, AT NO COST TO YOU, TO THE PROVISION OF CERTAIN ASSISTANCE. PLEASE CONTACT: ADA COORDINATOR, HUMAN RESOURCES, ORANGE COUNTY COURTHOUSE, 425 N. ORANGE AVENUE, SUITE 510, ORLANDO, FLORIDA, (407) 836-2303, FAX: 407-836-2204; AT LEAST 7 DAYS BEFORE YOUR SCHEDULED COURT APPEARANCE, OR IMMEDIATELY UPON RECEIVING NOIFICATION IF THE TIME BEFORE YOUR SCHEDULED COURT APPEARANCE IS LESS THAN 7 DAYS. IF YOU ARE HEARING IMPAIRED OR VOICE IMPAIRED, CALL 711 TO REACH THE TELECOMMUNICATIONS RELAY SERVICE.
/s/ Jason M. Vanslette
Jason M Vanslette, Esq.
FBN: 92121
Kelley Kronenberg
10360 West State Road 84
Fort Lauderdale, FL 33324
Phone: (954) 370-9970
Fax: (954) 252-4571
Service E-mail: flrealprop@kelleykronenberg.com
File No: L180313-JMV
Case No.: 2019-CA-000034-O
Sep. 24; Oct. 1, 2020 20-03785W

THE PUBLIC RECORDS OF ORANGE COUNTY, FLORIDA.
Property Address: 9782 PINEY POINT CIR, ORLANDO, FL 32825
Any person claiming an interest in the surplus from the sale, if any, other than the property owner as of the date of the lis pendens must file a claim in accordance with Florida Statutes, Section 45.031.
IMPORTANT AMERICANS WITH DISABILITIES ACT. If you are a person with a disability who needs any accommodation in order to participate in a court proceeding or event, you are entitled, at no cost to you, to the provision of certain assistance. Please contact Orange County, ADA Coordinator, Human Resources, Orange County Courthouse, 425 N. Orange Avenue, Suite 510, Orlando, Florida, (407) 836-2303, fax: 407-836-2204; and in Osceola County: ADA Coordinator, Court Administration, Osceola County Courthouse, 2 Courthouse Square, Suite 6300, Kissimmee, FL 34741, (407) 742-2417, fax 407-835-5079, at least 7 days before your scheduled court appearance, or immediately upon receiving notification if the time before the scheduled court appearance is less than 7 days. If you are hearing or voice impaired, call 711 to reach the Telecommunications Relay Service.
Dated this 16 day of September, 2020.
By: \S\Tiffanie Waldman
Tiffanie Waldman, Esquire
Florida Bar No. 86591
Communication Email: twaldman@rasflaw.com
ROBERTSON, ANSCHUTZ & SCHNEID, P.L.
Attorney for Plaintiff
6409 Congress Ave.,
Suite 100
Boca Raton, FL 33487
Telephone: 561-241-6901
Facsimile: 561-997-6909
Service Email: mail@rasflaw.com
17-073830 - MaS
Sep. 24; Oct. 1, 2020 20-03733W

FIRST INSERTION

NOTICE OF FORECLOSURE SALE IN THE CIRCUIT COURT OF THE NINTH JUDICIAL CIRCUIT IN AND FOR ORANGE COUNTY, FLORIDA GENERAL JURISDICTION DIVISION
CASE NO. 2017-CA-007897-O THE BANK OF NEW YORK MELLON, F/K/A THE BANK OF NEW YORK AS SUCCESSOR IN INTEREST TO JPMORGAN CHASE BANK, N.A. AS TRUSTEE FOR NOVASTAR MORTGAGE FUNDING TRUST, SERIES 2006-3, NOVASTAR HOME EQUITY LOAN ASSET-BACKED CERTIFICATES, SERIES 2006-3, Plaintiff, vs. DONNA KUBIK, et al. Defendant(s).
NOTICE IS HEREBY GIVEN pursuant to a Final Judgment of Foreclosure dated January 17, 2020, and entered in 2017-CA-007897-O of the Circuit Court of the NINTH Judicial Circuit in and for Orange County, Florida, wherein THE BANK OF NEW YORK MELLON, F/K/A THE BANK OF NEW YORK AS SUCCESSOR IN INTEREST TO JPMORGAN CHASE BANK, N.A. AS TRUSTEE FOR NOVASTAR MORTGAGE FUNDING TRUST, SERIES 2006-3, NOVASTAR HOME EQUITY LOAN ASSET-BACKED CERTIFICATES, SERIES 2006-3 is the Plaintiff and DONNA KUBIK; SCOTT A KELLY AKA SCOTT E KELLY; FLORIDA TECHNICAL COLLEGE, INC. are the Defendant(s). Tiffany Moore Russell as the Clerk of the Circuit Court will sell to the highest and best bidder for cash at www.myorangeclerk.realforeclose.com, at 11:00 AM, on October 14, 2020, the following described property as set forth in said Final Judgment, to wit:
THE EAST 49.00 FEET OF LOT 11, PINEY WOODS POINT, ACCORDING TO THE PLAT THEREOF, RECORDED IN PLAT BOOK 13, PAGE 127, OF

THE PLAT THEREOF, AS RECORDED IN PLAT BOOK 34, PAGES 1 THROUGH 3, OF THE PUBLIC RECORDS OF ORANGE COUNTY, FLORIDA.
Property Address: 13800 GREENEBRIDGE COURT, ORLANDO, FL 32824
Any person claiming an interest in the surplus from the sale, if any, other than the property owner as of the date of the lis pendens must file a claim in accordance with Florida Statutes, Section 45.031.
IMPORTANT AMERICANS WITH DISABILITIES ACT. If you are a person with a disability who needs any accommodation in order to participate in a court proceeding or event, you are entitled, at no cost to you, to the provision of certain assistance. Please contact Orange County, ADA Coordinator, Human Resources, Orange County Courthouse, 425 N. Orange Avenue, Suite 510, Orlando, Florida, (407) 836-2303, fax: 407-836-2204; and in Osceola County: ADA Coordinator, Court Administration, Osceola County Courthouse, 2 Courthouse Square, Suite 6300, Kissimmee, FL 34741, (407) 742-2417, fax 407-835-5079, at least 7 days before your scheduled court appearance, or immediately upon receiving notification if the time before the scheduled court appearance is less than 7 days. If you are hearing or voice impaired, call 711 to reach the Telecommunications Relay Service.
Dated this 16 day of September, 2020.
By: \S\Tiffanie Waldman
Tiffanie Waldman, Esquire
Florida Bar No. 86591
Communication Email: twaldman@rasflaw.com
ROBERTSON, ANSCHUTZ & SCHNEID, P.L.
Attorney for Plaintiff
6409 Congress Ave.,
Suite 100
Boca Raton, FL 33487
Telephone: 561-241-6901
Facsimile: 561-997-6909
Service Email: mail@rasflaw.com
17-073830 - MaS
Sep. 24; Oct. 1, 2020 20-03733W

FIRST INSERTION

NOTICE OF FORECLOSURE SALE IN THE CIRCUIT COURT OF THE 9TH JUDICIAL CIRCUIT IN AND FOR ORANGE COUNTY, FLORIDA
CASE NO.: 2019-CA-000034-O FIRST EQUITY MORTGAGE BANKERS, INC., Plaintiff, v. THE UNKNOWN HEIRS, DEVISEES, GRANTEEES, ASSIGNEES, CREDITORS, LIENORS AND TRUSTEES OF WILLIE C. GILBERT, ET AL., Defendants.
NOTICE IS HEREBY GIVEN pursuant to a Final Judgment dated September 21, 2020 entered in Civil Case No. 2019-CA-000034-O in the Circuit Court of the Ninth Judicial Circuit in and for Orange County, Florida, wherein FIRST EQUITY MORTGAGE BANKERS, INC., Plaintiff and THE UNKNOWN HEIRS, DEVISEES, GRANTEEES, ASSIGNEES, CREDITORS, LIENORS AND TRUSTEES OF WILLIE C. GILBERT; CYNTHIA TRIM GILBERT; ALL UNKNOWN PARTIES CLAIMING INTERESTS BY, THROUGH, UNDER OR AGAINST A NAMED DEFENDANT TO THIS ACTION, OR HAVING OR CLAIMING TO HAVE ANY RIGHT, TITLE OR INTEREST IN THE PROPERTY HEREIN DESCRIBED; ORLANDO HEALTH, INC.; ORANGE COUNTY, FLORIDA; F.A. MANAGEMENT SOLUTIONS, INC.; TYEESSE BARNES; JESSIE REE HORN; WILLIE C. GILBERT, JR., are defendants, Clerk of Court, will sell the property at public sale at www.myorangeclerk.realforeclose.com beginning at 11:00 AM on November 3, 2020 the following described property as set forth in said Final Judgment, to-wit:
LOT 5, BLOCK 1, TANGELO PARK SECTION ONE, ACCORDING TO THE PLAT THEREOF AS RECORDED IN PLAT BOOK W, PAGE 100, OF THE PUBLIC RECORDS OF ORANGE COUNTY, FLORIDA.
Property Address: 7727 Nectar Drive, Orlando, FL 32819
ANY PERSON CLAIMING AN INTEREST IN THE SURPLUS FROM THE SALE, IF ANY, OTHER THAN THE PROPERTY OWNER AS OF THE DATE OF THE LIS PENDENS MUST FILE A CLAIM BEFORE THE CLERK REPORTS THE SURPLUS AS UNCLAIMED.
THE COURT, IN ITS DISCRETION, MAY ENLARGE THE TIME OF THE SALE. NOTICE OF THE CHANGED TIME OF SALE SHALL BE PUBLISHED AS PROVIDED HEREIN.
IF YOU ARE A PERSON WITH A DISABILITY WHO NEEDS ANY ACCOMMODATION IN ORDER TO PARTICIPATE IN A COURT PROCEEDING OR EVENT, YOU ARE ENTITLED, AT NO COST TO YOU, TO THE PROVISION OF CERTAIN ASSISTANCE. PLEASE CONTACT: ADA COORDINATOR, HUMAN RESOURCES, ORANGE COUNTY COURTHOUSE, 425 N. ORANGE AVENUE, SUITE 510, ORLANDO, FLORIDA, (407) 836-2303, FAX: 407-836-2204; AT LEAST 7 DAYS BEFORE YOUR SCHEDULED COURT APPEARANCE, OR IMMEDIATELY UPON RECEIVING NOIFICATION IF THE TIME BEFORE YOUR SCHEDULED COURT APPEARANCE IS LESS THAN 7 DAYS. IF YOU ARE HEARING IMPAIRED OR VOICE IMPAIRED, CALL 711 TO REACH THE TELECOMMUNICATIONS RELAY SERVICE.
/s/ Jason M Vanslette
Jason M Vanslette, Esq.
FBN: 92121
Kelley Kronenberg
10360 West State Road 84
Fort Lauderdale, FL 33324
Phone: (954) 370-9970
Fax: (954) 252-4571
Service E-mail: flrealprop@kelleykronenberg.com
File No: L180313-JMV
Case No.: 2019-CA-000034-O
Sep. 24; Oct. 1, 2020 20-03730W

NOTICE OF FORECLOSURE SALE IN THE CIRCUIT COURT OF THE NINTH JUDICIAL CIRCUIT IN AND FOR ORANGE COUNTY, FLORIDA GENERAL JURISDICTION DIVISION
CASE NO. 2016-CA-000325-O THE BANK OF NEW YORK MELLON, F/K/A THE BANK OF NEW YORK, AS TRUSTEE FOR THE CERTIFICATE HOLDERS OF THE CWABS INC., ASSET-BACKED CERTIFICATES SERIES 2007-BC3, Plaintiff, vs. RANDOLPH MORALES AND LOURDES M. SOSA A/K/A LOURDES MARGARITA SOSA PRIETO, et al. Defendant(s).
NOTICE IS HEREBY GIVEN pursuant to a Final Judgment of Foreclosure dated February 03, 2017, and entered in 2016-CA-000325-O of the Circuit Court of the NINTH Judicial Circuit in and for Orange County, Florida, wherein THE BANK OF NEW YORK MELLON, F/K/A THE BANK OF NEW YORK, AS TRUSTEE FOR THE CERTIFICATE HOLDERS OF THE CWABS INC., ASSET-BACKED CERTIFICATES SERIES 2007-BC3 is the Plaintiff and RANDOLPH MORALES; LOURDES M. SOSA A/K/A LOURDES MARGARITA SOSA PRIETO; UNKNOWN SPOUSE OF RANDOLPH MORALES N/K/A MARIA MORALES; WOODBRIDGE AT MEADOW WOODS HOMEOWNERS' ASSOCIATION, INC.; STATE OF FLORIDA, AGENCY FOR WORKFORCE INNOVATION, UNEMPLOYMENT COMPENSATION PROGRAM are the Defendant(s). Tiffany Moore Russell as the Clerk of the Circuit Court will sell to the highest and best bidder for cash at www.myorangeclerk.realforeclose.com, at 11:00 AM, on October 14, 2020, the following described property as set forth in said Final Judgment, to wit:
LOT 32, BLOCK 188, WOODBRIDGE AT MEADOW WOODS, ACCORDING TO

FIRST INSERTION

NOTICE OF FORECLOSURE SALE IN THE CIRCUIT COURT OF THE NINTH JUDICIAL CIRCUIT IN AND FOR ORANGE COUNTY, FLORIDA GENERAL JURISDICTION DIVISION
CASE NO. 2016-CA-000325-O THE BANK OF NEW YORK MELLON, F/K/A THE BANK OF NEW YORK, AS TRUSTEE FOR THE CERTIFICATE HOLDERS OF THE CWABS INC., ASSET-BACKED CERTIFICATES SERIES 2007-BC3, Plaintiff, vs. RANDOLPH MORALES AND LOURDES M. SOSA A/K/A LOURDES MARGARITA SOSA PRIETO, et al. Defendant(s).
NOTICE IS HEREBY GIVEN pursuant to a Final Judgment of Foreclosure dated February 03, 2017, and entered in 2016-CA-000325-O of the Circuit Court of the NINTH Judicial Circuit in and for Orange County, Florida, wherein THE BANK OF NEW YORK MELLON, F/K/A THE BANK OF NEW YORK, AS TRUSTEE FOR THE CERTIFICATE HOLDERS OF THE CWABS INC., ASSET-BACKED CERTIFICATES SERIES 2007-BC3 is the Plaintiff and RANDOLPH MORALES; LOURDES M. SOSA A/K/A LOURDES MARGARITA SOSA PRIETO; UNKNOWN SPOUSE OF RANDOLPH MORALES N/K/A MARIA MORALES; WOODBRIDGE AT MEADOW WOODS HOMEOWNERS' ASSOCIATION, INC.; STATE OF FLORIDA, AGENCY FOR WORKFORCE INNOVATION, UNEMPLOYMENT COMPENSATION PROGRAM are the Defendant(s). Tiffany Moore Russell as the Clerk of the Circuit Court will sell to the highest and best bidder for cash at www.myorangeclerk.realforeclose.com, at 11:00 AM, on October 14, 2020, the following described property as set forth in said Final Judgment, to wit:
LOT 32, BLOCK 188, WOODBRIDGE AT MEADOW WOODS, ACCORDING TO

THE PLAT THEREOF, AS RECORDED IN PLAT BOOK 34, PAGES 1 THROUGH 3, OF THE PUBLIC RECORDS OF ORANGE COUNTY, FLORIDA.
Property Address: 13800 GREENEBRIDGE COURT, ORLANDO, FL 32824
Any person claiming an interest in the surplus from the sale, if any, other than the property owner as of the date of the lis pendens must file a claim in accordance with Florida Statutes, Section 45.031.
IMPORTANT AMERICANS WITH DISABILITIES ACT. If you are a person with a disability who needs any accommodation in order to participate in a court proceeding or event, you are entitled, at no cost to you, to the provision of certain assistance. Please contact Orange County, ADA Coordinator, Human Resources, Orange County Courthouse, 425 N. Orange Avenue, Suite 510, Orlando, Florida, (407) 836-2303, fax: 407-836-2204; and in Osceola County: ADA Coordinator, Court Administration, Osceola County Courthouse, 2 Courthouse Square, Suite 6300, Kissimmee, FL 34741, (407) 742-2417, fax 407-835-5079, at least 7 days before your scheduled court appearance, or immediately upon receiving notification if the time before the scheduled court appearance is less than 7 days. If you are hearing or voice impaired, call 711 to reach the Telecommunications Relay Service.
Dated this 16 day of September, 2020.
By: \S\Tiffanie Waldman
Tiffanie Waldman, Esquire
Florida Bar No. 86591
Communication Email: twaldman@rasflaw.com
ROBERTSON, ANSCHUTZ & SCHNEID, P.L.
Attorney for Plaintiff
6409 Congress Ave., Suite 100
Boca Raton, FL 33487
Telephone: 561-241-6901
Facsimile: 561-997-6909
Service Email: mail@rasflaw.com
15-014763 - MaS
Sep. 24; Oct. 1, 2020 20-03731W

ORANGE COUNTY

FIRST INSERTION

NOTICE OF FORECLOSURE SALE IN THE CIRCUIT COURT OF THE NINTH JUDICIAL CIRCUIT IN AND FOR ORANGE COUNTY, FLORIDA GENERAL JURISDICTION DIVISION CASE NO.

482018CA011548A0010X U.S. BANK NATIONAL ASSOCIATION, AS TRUSTEE FOR BANC OF AMERICA FUNDING 2008-FT1 TRUST, MORTGAGE PASS-THROUGH CERTIFICATES, SERIES 2008-FT1, Plaintiff, vs.

KEEM A. LALA, et al., Defendant(s). NOTICE IS HEREBY GIVEN pursuant to the Final Judgment and/or Order Rescheduling Foreclosure Sale, entered in Case No. 482018CA011548A0010X of the Circuit Court of the NINTH Judicial Circuit, in and for Orange County, Florida, wherein U.S. Bank National Association, as Trustee for Banc of America Funding 2008-FT1 Trust, Mortgage Pass-Through Certificates, Series 2008-FT1 is the Plaintiff and Akeem A. Lala; Unknown Spouse of Akeem A. Lala; The Meadows at Boggy Creek Homeowners Association, Inc.; Mubo A. Lala a/k/a Mubo Aderonke Lala; Unknown Spouse of Mubo A. Lala a/k/a Mubo Aderonke Lala are the Defendants, that Tiffany Russell, Orange County Clerk of Court will sell to the highest and best bidder for cash at, www.myorangeclerk.realforeclose.com, beginning at 11:00AM on the 12th day of October, 2020, the following described property as set forth in

said Final Judgment, to wit: LOT 176, THE MEADOWS AT BOGGY CREEK, ACCORDING TO THE PLAT THEREOF, AS RECORDED IN PLAT BOOK 32, PAGES 75 THROUGH 78, INCLUSIVE OF THE PUBLIC RECORDS OF ORANGE COUNTY, FLORIDA.

Any person claiming an interest in the surplus from the sale, if any, other than the property owner as of the date of the lis pendens must file a claim before the clerk reports the surplus as unclaimed. If you are a person with a disability who needs any accommodation in order to participate in this proceeding, you are entitled, at no cost to you, to the provision of certain assistance. Please contact the ADA Coordinator, Human Resources, Orange County Courthouse, 425 N. Orange Avenue, Suite 510, Orlando, Florida, (407) 836-2303, at least 7 days before your scheduled court appearance, or immediately upon receiving this notification if the time before the scheduled appearance is less than 7 days; if you are hearing or voice impaired, call 711.

Dated this 22nd day of September, 2020.

By: /s/ Mehwish Yousuf Mehwish Yousuf, Esq. Florida Bar No. 92171

BROCK & SCOTT, PLLC Attorney for Plaintiff 2001 NW 64th St, Suite 130 Ft. Lauderdale, FL 33309 Phone: (954) 618-6955, ext. 6133 Fax: (954) 618-6954 FLCourtDocs@brockandscott.com File No. 18-F02082 Sep. 24; Oct. 1, 2020 20-03791W

FIRST INSERTION

NOTICE OF ACTION IN THE CIRCUIT COURT OF THE NINTH JUDICIAL CIRCUIT, IN AND FOR ORANGE COUNTY, FLORIDA

CASE NO. 2017-CA-003616-O U.S. BANK NATIONAL ASSOCIATION, AS TRUSTEE, SUCCESSOR IN INTEREST TO BANK OF AMERICA, NATIONAL ASSOCIATION, AS TRUSTEE, SUCCESSOR BY MERGER TO LASALLE BANK NATIONAL ASSOCIATION, AS TRUSTEE, FOR THE HOLDERS OF THE RAAC SERIES 2007-SP2 TRUST, MORTGAGE ASSET-BACKED PASS-THROUGH CERTIFICATES, SERIES 2007-SP2, Plaintiff, vs. UNKNOWN HEIRS OF GHISLAINE CENACLE; SPENCER CENACLE A/K/A SPENCER J. CENACLE, ET AL. Defendants

To the following Defendant(s): SPENCER CENACLE A/K/A SPENCER J. CENACLE (CURRENT RESIDENCE UNKNOWN) Last Known Address: 6520 METROWEST BLVD APT 715, ORLANDO, FL 32835 Additional Address: 8110 COUNTRY RUN PARKWAY, ORLANDO, FL 32818

YOU ARE HEREBY NOTIFIED that an action for Foreclosure of Mortgage on the following described property: LOT NUMBER 143, COUNTRY RUN, ACCORDING TO THE PLAT THEREOF, RECORDED IN PLAT BOOK 21, PAGES 89 THROUGH 91 OF THE PUBLIC RECORDS OF ORANGE COUNTY, FLORIDA A/K/A 8110 COUNTRY RUN PARKWAY, ORLANDO, FL 32818

has been filed against you and you are required to serve a copy of your written defenses, if any, to J. Anthony Van Ness, Esq. at VAN NESS LAW FIRM, PLC, Attorney for the Plaintiff, whose address is 1239 E. NEWPORT CENTER DRIVE, SUITE #110, DEERFIELD BEACH, FL 33442 on or before a date which is within thirty (30) days after the first publication of this Notice in the THE BUSINESS OBSERVER and file the original with the Clerk of this Court either before service on Plaintiff's attorney or immediately thereafter; otherwise a default will be entered against you for the relief demanded in the complaint. This notice is provided to Administrative Order No. 2065.

If you are a person with a disability who needs any accommodation in order to participate in a court proceeding or event, you are entitled, at no cost to you, to the provision of certain assistance. Please contact Orange County, ADA Coordinator, Human Resources, Orange County Courthouse, 425 N. Orange Avenue, Suite 510, Orlando, Florida, (407) 836-2303, fax: 407-836-2204; at least 7 days before your scheduled court appearance, or immediately upon receiving notification if the time before the scheduled court appearance is less than 7 days. If you are hearing or voice impaired, call 711 to reach the Telecommunications Relay Service.

TIFFANY M. RUSSELL ORANGE COUNTY CLERK OF COURT By Sandra Jackson, Deputy Clerk 2020-09-14 08:57:23 As Deputy Clerk 425 North Orange Ave. Suite 350 Orlando, Florida 32801 PHH4337-17/be Sep. 24; Oct. 1, 2020 20-03669W

FIRST INSERTION

NOTICE OF ACTION IN THE CIRCUIT COURT OF THE NINTH JUDICIAL CIRCUIT OF FLORIDA IN AND FOR ORANGE COUNTY GENERAL JURISDICTION DIVISION

CASE NO. 2020-CA-002159-O WILMINGTON SAVINGS FUND SOCIETY, FSB, D/B/A CHRISTIANA TRUST, NOT INDIVIDUALLY BUT AS TRUSTEE FOR HILLDALE TRUST, Plaintiff, vs.

ISMAEL R. DOVALE, et al. Defendants. To: ISMAEL R. DOVALE 10313 STONE GLEN DRIVE, ORLANDO, FL 32825 YADIRA N. DOVALE 10313 STONE GLEN DRIVE, ORLANDO, FL 32825 LAST KNOWN ADDRESS STATED, CURRENT RESIDENCE UNKNOWN YOU ARE HEREBY NOTIFIED that an action to foreclose Mortgage covering the following real and personal property described as follows, to-wit:

LOT 29, OF STONEWOOD ESTATES AT CYPRESS SPRINGS II, ACCORDING TO THE PLAT THEREOF, AS RECORDED IN PLAT BOOK 42, AT PAGES 63

THROUGH 66, OF THE PUBLIC RECORDS OF ORANGE COUNTY, FLORIDA.

has been filed against you and you are required to file a copy of your written defenses, if any, to it on Sara Collins, McCalla Raymer Leibert Pierce, LLC, 225 E. Robinson St. Suite 155, Orlando, FL 32801 and file the original with the Clerk of the above- styled Court on or before XXXXXXXXXXXXXXXX or 30 days from the first publication, otherwise a Judgment may be entered against you for the relief demanded in the Complaint.

Tiffany Moore Russell CLERK OF THE CIRCUIT COURT As Clerk of the Court BY: Sandra Jackson, Deputy Clerk 2020-09-15 07:42:04 Deputy Clerk 425 North Orange Ave. Suite 350 Orlando, Florida 32801 MCCALLA RAYMER LEIBERT PIERCE, LLC 225 E. Robinson St. Suite 155 Orlando, FL 32801 Phone: (407) 674-1850 Fax: (321) 248-0420 6646968 18-00561-2 Sep. 24; Oct. 1, 2020 20-03665W

FIRST INSERTION

NOTICE OF FORECLOSURE SALE IN THE CIRCUIT COURT OF THE NINTH JUDICIAL CIRCUIT IN AND FOR ORANGE COUNTY, FLORIDA

CASE NO.: 2017-CA-007750-O U.S. BANK TRUST NATIONAL ASSOCIATION, NOT IN ITS INDIVIDUAL CAPACITY BUT SOLELY AS OWNER TRUSTEE FOR CARISBROOK ASSET HOLDING TRUST, Plaintiff, v. THOMAS PALIN, III A/K/A THOMAS P. PALIN, III; et al., Defendants.

NOTICE is hereby given that Tiffany Moore Russell, Clerk of the Circuit Court of Orange County, Florida, will on October 20, 2020, at 11:00 A.M. EST, via the online auction site at www.myorangeclerk.realforeclose.com in accordance with Chapter 45, F.S., offer for sale and sell to the highest and best bidder for cash, the following described property situated in Orange County, Florida, to wit:

Lot 327 of ARBOR RIDGE PHASE 4, according to the plat thereof as recorded in Plat Book 72, Pages 31 through 36, of the Public Records of Orange County, Florida. Property Address: 2679 Breezy Meadow Road, Apopka, FL 32712 pursuant to the Final Judgment of Foreclosure entered in a case pending in said Court, the style and case number of which is set forth above.

Any person claiming an interest in the surplus from the sale, if any, other than the property owner as of the date

of the Lis Pendens must file a claim before the clerk reports the surplus as unclaimed.

If the sale is set aside for any reason, the Purchaser at the sale shall be entitled only to a return of the deposit paid. The Purchaser shall have no further recourse against the Mortgagor, the Mortgagee or the Mortgagee's attorney.

If you are a person with a disability who needs any accommodation in order to participate in this proceeding, you are entitled, at no cost to you, to the provision of certain assistance. Please contact the ADA Coordinator, Human Resources, Orange County Courthouse, 425 N. Orange Avenue, Suite 510, Orlando, Florida, (407) 836-2303, Email: ctadmd2@ocnjcc.org, at least 7 days before your scheduled court appearance, or immediately upon receiving this notification if the time before the scheduled court appearance is less than 7 days; if you are hearing or voice impaired, call 711.

SUBMITTED on this 22nd day of September, 2020.

TIFFANY & BOSCO, P.A. /s/ Kathryn I. Kasper, Esq. Anthony R. Smith, Esq. FL Bar #157147 Kathryn I. Kasper, Esq. FL Bar #621188 Attorneys for Plaintiff

OF COUNSEL: Tiffany & Bosco, P.A. 1201 S. Orlando Ave, Suite 430 Winter Park, FL 32789 Toll Free: (800) 826-1699 Facsimile: (850) 462-1599 Sep. 24; Oct. 1, 2020 20-03789W

FIRST INSERTION

NOTICE OF FORECLOSURE SALE IN THE CIRCUIT COURT OF THE NINTH JUDICIAL CIRCUIT IN AND FOR ORANGE COUNTY, FLORIDA GENERAL JURISDICTION DIVISION

CASE NO. 2018-CA-003118-O DEUTSCHE BANK NATIONAL TRUST COMPANY, AS TRUSTEE FOR NOVASTAR MORTGAGE FUNDING TRUST, SERIES 2007-2, NOVASTAR HOME EQUITY LOAN ASSET-BACKED CERTIFICATES, SERIES 2007-2, Plaintiff, vs. TYRONE S GEE, et al. Defendant(s).

NOTICE IS HEREBY GIVEN pursuant to a Final Judgment of Foreclosure dated September 11, 2020, and entered in 2018-CA-003118-O of the Circuit Court of the NINTH Judicial Circuit in and for Orange County, Florida, wherein DEUTSCHE BANK NATIONAL TRUST COMPANY, AS TRUSTEE FOR NOVASTAR MORTGAGE FUNDING TRUST, SERIES 2007-2, NOVASTAR HOME EQUITY LOAN ASSET-BACKED CERTIFICATES, SERIES 2007-2 is the Plaintiff and TYRONE S GEE; IDANIA SANCHEZ; AMERICAN BANKERS INSURANCE COMPANY OF FLORIDA; POLAKOFF BAIL BONDS; STATE OF FLORIDA, DEPARTMENT OF REVENUE; CLERK OF THE CIRCUIT COURT ORANGE COUNTY, FLORIDA; ROYAL MANOR ESTATES PHASE TWO HOMEOWNERS' ASSOCIATION, INC. are the Defendant(s). Tiffany Moore Russell as the Clerk of the Circuit Court will sell to the highest and best bidder for cash at www.myorangeclerk.realforeclose.com, at 11:00 AM, on October 15, 2020, the following described property as set forth in said Final Judgment, to wit:

LOT(S) 23, ROYAL MANOR ESTATES, PHASE FOUR, ACCORDING TO THE PLAT THEREOF, RECORDED IN PLAT BOOK 21, PAGE(S) 13-14,

OF THE PUBLIC RECORDS OF ORANGE COUNTY, FLORIDA. Property Address: 2015 AMBERGRIS DRIVE, ORLANDO, FL 32822

Any person claiming an interest in the surplus from the sale, if any, other than the property owner as of the date of the lis pendens must file a claim in accordance with Florida Statutes, Section 45.031.

IMPORTANT AMERICANS WITH DISABILITIES ACT. If you are a person with a disability who needs any accommodation in order to participate in a court proceeding or event, you are entitled, at no cost to you, to the provision of certain assistance. Please contact Orange County, ADA Coordinator, Human Resources, Orange County Courthouse, 425 N. Orange Avenue, Suite 510, Orlando, Florida, (407) 836-2303, fax: 407-836-2204; and in Osceola County: ADA Coordinator, Court Administration, Osceola County Courthouse, 2 Court-house Square, Suite 6300, Kissimmee, FL 34741, (407) 742-2417, fax 407-835-5079, at least 7 days before your scheduled court appearance, or immediately upon receiving notification if the time before the scheduled court appearance is less than 7 days. If you are hearing or voice impaired, call 711 to reach the Telecommunications Relay Service. Dated this 22 day of September, 2020.

By: /s/ Tiffanie Waldman Tiffanie Waldman, Esquire Florida Bar No. 86591 Communication Email: twaldman@rasflaw.com ROBERTSON, ANSCHUTZ & SCHNEID, P.L.L.C. Attorney for Plaintiff 6409 Congress Ave., Suite 100 Boca Raton, FL 33487 Telephone: 561-241-6901 Facsimile: 561-997-6909 Service Email: mail@rasflaw.com 17-074067 - NaC Sep. 24; Oct. 1, 2020 20-03807W

OFFICIAL COURTHOUSE WEBSITES:

MANATEE COUNTY:
manateeclerk.com

SARASOTA COUNTY:
sarasotaclerk.com

CHARLOTTE COUNTY:
charlotte.realforeclose.com

LEE COUNTY:
leeclerk.org

COLLIER COUNTY:
collierclerk.com

HILLSBOROUGH COUNTY:
hillsclerk.com

PASCO COUNTY:
pasco.realforeclose.com

PINELLAS COUNTY:
pinellasclerk.org

POLK COUNTY:
polkcountyclerk.net

ORANGE COUNTY:
myorangeclerk.com

Check out your notices on: floridapublicnotices.com

Business Observer

Q&A

What makes public notices in newspapers superior to other forms of notices?

Public notices in newspapers are serendipitous. When readers page through a newspaper, they will find important public notice information they otherwise would not find anywhere else.

Rarely do consumers specifically search online for public notices.

VIEW NOTICES ONLINE AT
Legals.BusinessObserverFL.com

To publish your legal notice call:
941-906-9386

ORANGE COUNTY
SUBSEQUENT INSERTIONS

SECOND INSERTION

NOTICE TO CREDITORS
IN THE CIRCUIT COURT FOR
ORANGE COUNTY, FLORIDA
PROBATE DIVISION
File No. 20-CP-2201
IN RE: ESTATE OF
YVONNE LANDRAU,
Deceased.

The administration of the estate of YVONNE LANDRAU, deceased, whose date of death was April 25, 2020, is pending in the Circuit Court for Orange County, Florida, Probate Division, the address of which is 425 N. Orange Avenue, Orlando, FL 32801. The names and addresses of the personal representative and the personal representative's attorney are set forth below.

All creditors of the decedent and other persons having claims or demands against decedent's estate, on whom a copy of this notice is required to be served, must file their claims with this court ON OR BEFORE THE LATER OF 3 MONTHS AFTER THE TIME OF THE FIRST PUBLICATION OF THIS NOTICE OR 30 DAYS AFTER THE DATE OF SERVICE OF A COPY OF THIS NOTICE ON THEM.

All other creditors of the decedent and other persons having claims or demands against decedent's estate must file their claims with this court WITHIN 3 MONTHS AFTER THE DATE OF THIS NOTICE.

ALL CLAIMS NOT FILED WITHIN THE TIME PERIODS SET FORTH IN FLORIDA STATUTES SECTION 733.702 WILL BE FOREVER BARRED.

NOTWITHSTANDING THE TIME PERIOD SET FORTH ABOVE, ANY CLAIM FILED TWO (2) YEARS OR MORE AFTER THE DECEDENT'S DATE OF DEATH IS BARRED.

The date of first publication of this notice is: September 17, 2020.

PEDRO LANDRAU
Personal Representative
1577 Avleigh Circle
Orlando, FL 32824
Robert D. Hines, Esq.
Attorney for Personal Representatives
Florida Bar No. 0413550
Hines Norman Hines, P.L.
1312 W. Fletcher Avenue, Suite B
Tampa, FL 33612
Telephone: 813-265-0100
Email: rhines@hnh-law.com
Secondary Email:
jrvera@hnh-law.com
September 17, 24, 2020 20-03653W

SECOND INSERTION

NOTICE TO CREDITORS
IN THE CIRCUIT COURT FOR
ORANGE COUNTY, FLORIDA
PROBATE DIVISION
File Number:
48 - 2020 - CP - 002263 - O
In Re The Estate Of:
Clifford Donald Chase, a/k/a Clifford
D. Chase, a/k/a Clifford Chase,
Deceased.

The formal administration of the Estate of Clifford Donald Chase a/k/a Clifford D. Chase, a/k/a Clifford Chase, deceased, File Number 48 - 2020 - CP - 002263 - O, has commenced in the Probate Division of the Circuit Court, Orange County, Florida, the address of which is 425 North Orange Avenue, Orlando, Florida 32802. The names and addresses of the Personal Representative and the Personal Representative's attorney are set forth below.

All creditors of the decedent, and other persons having claims or demands against the decedent's estate on whom a copy of this notice has been served must file their claims with this Court at the address set forth above WITHIN THREE MONTHS AFTER THE DATE OF SERVICE OF A COPY OF THIS NOTICE ON SUCH CREDITOR.

All other creditors or persons having claims or demands against decedent's estate on whom a copy of this notice has not been served must file their claims with this Court at the address set forth above WITHIN THREE MONTHS AFTER THE DATE OF THE FIRST PUBLICATION OF THIS NOTICE AS SET FORTH BELOW.

ALL CLAIMS AND DEMANDS NOT FILED WITHIN THE TIME PERIODS SET FORTH IN SECTION 733.702 OF THE FLORIDA PROBATE CODE WILL BE FOREVER BARRED.

NOTWITHSTANDING THE TIME PERIODS SET FORTH ABOVE, ANY CLAIM FILED TWO (2) YEARS OR MORE AFTER THE DECEDENT'S DATE OF DEATH IS BARRED.

The date of first publication of this notice is September 17, 2020.

Personal Representative:
Scott Alan Chase
352 Blue Stone Circle
Winter Garden, Florida 34787
Attorney for Personal Representative:
Blair M. Johnson
Blair M. Johnson, P.A.
Post Office Box 770496
Winter Garden, Florida 34777-0496
Phone number: (407) 656-5521
Fax number: (407) 656-0305
Blair@westorangelaw.com
Florida Bar Number: 296171
September 17, 24, 2020 20-03654W

SECOND INSERTION

NOTICE TO CREDITORS
IN THE CIRCUIT COURT FOR
ORANGE COUNTY, FLORIDA
PROBATE DIVISION
File No. 48-2020-CP-002277-O
Division Probate
IN RE: ESTATE OF
JACQUELINE A. HOEPFNER
a/k/a JACQUELINE ANN
HOEPFNER
a/k/a JACQUELINE KUHNS
Deceased.

The administration of the estate of JACQUELINE A. HOEPFNER, deceased, whose date of death was August 1, 2020, is pending in the Circuit Court for Orange County, Florida, Probate Division, the address of which is 425 N. Orange Ave # 340, Orlando, Florida 32801. The names and addresses of the personal representative and the personal representative's attorney are set forth below.

All creditors of the decedent and other persons having claims or demands against decedent's estate on whom a copy of this notice is required to be served must file their claims with this court ON OR BEFORE THE LATER OF 3 MONTHS AFTER THE TIME OF THE FIRST PUBLICATION OF THIS NOTICE OR 30 DAYS AFTER THE DATE OF SERVICE OF A COPY OF THIS NOTICE ON THEM.

All other creditors of the decedent and other persons having claims or demands against decedent's estate must file their claims with this court WITHIN 3 MONTHS AFTER THE DATE OF THIS NOTICE.

ALL CLAIMS NOT FILED WITHIN THE TIME PERIODS SET FORTH IN FLORIDA STATUTES SECTION 733.702 WILL BE FOREVER BARRED.

NOTWITHSTANDING THE TIME PERIODS SET FORTH ABOVE, ANY CLAIM FILED TWO (2) YEARS OR MORE AFTER THE DECEDENT'S DATE OF DEATH IS BARRED.

The date of first publication of this notice is September 17, 2020.

Personal Representative:
KATHERINE I. MATALONE
3353 Cloudberry Place
Melbourne, Florida 32940
Attorney for Personal Representative:
ANNE J. MCPHEE
Email Address:
Anne@StudenbergLaw.com
Florida Bar No. 0041605
Ganon J. Studenberg, P.A.
1119 Palmetto Avenue
Melbourne, Florida 32901
September 17, 24, 2020 20-03608W

SECOND INSERTION

NOTICE TO CREDITORS
IN THE CIRCUIT COURT FOR
ORANGE COUNTY, FLORIDA
PROBATE DIVISION
File No. 2020-CP-2286-O
IN RE: ESTATE OF
ROSEMARIE SANTIAGO,
Deceased.

The administration of the estate of ROSEMARIE SANTIAGO deceased, File Number 2020-CP-2286-O is pending in the Circuit Court for Orange County, Florida, Probate Division, the address of which is 425 N. Orange Ave., Orlando, Florida 32801. The names and addresses of the Personal Representative and the Personal Representative's attorney are set forth below.

All creditors of the decedent and other persons having claims or demands against decedent's estate, including unmatured, contingent or unliquidated claims, on whom a copy of this notice is served must file their claims with this Court WITHIN THE LATER OF THREE (3) MONTHS AFTER THE DATE OF THE FIRST PUBLICATION OF THIS NOTICE OR THIRTY (30) DAYS AFTER THE DATE OF SERVICE OF A COPY OF THIS NOTICE ON THEM.

All other creditors of the decedent and other persons having claims or demands against decedent's estate, including unmatured, contingent or unliquidated claims, must file their claims with this Court WITHIN THREE (3) MONTHS AFTER THE DATE OF THE FIRST PUBLICATION OF THIS NOTICE.

ALL CLAIMS NOT SO FILED WILL BE FOREVER BARRED.

NOTWITHSTANDING THE TIME PERIODS SET FORTH ABOVE, ANY CLAIM FILED TWO (2) YEARS OR MORE AFTER THE DECEDENT'S DATE OF DEATH IS BARRED.

The date of first publication of this notice is: September 17, 2020.

GABRIELLE SANTIAGO,
Personal Representative
1237 Madeira Key Way
Orlando, FL 32824
STACEY R. SPRINGER, Esquire
Florida Bar No. 519855
Primary E-Mail for Service:
service.srspringer@stenstrom.com
Secondary E-mail:
srspringer@stenstrom.com
STENSTROM, McINTOSH,
COLBERT, & WHIGHAM, P.A.
300 International Parkway,
Suite 100
Lake Mary, Florida 32746
Telephone: (407) 322-2171
September 17, 24, 2020 20-03610W

SECOND INSERTION

NOTICE TO CREDITORS
IN THE CIRCUIT COURT FOR
ORANGE COUNTY, FLORIDA
PROBATE DIVISION
File No. 2020-CP-001964-O
IN RE: ESTATE OF
CAROL L. TRIPP
a/k/a LYNNE BATTEN TRIPP
Deceased.

The administration of the estate of CAROL L. TRIPP, also known as LYNNE BATTEN TRIPP, deceased, whose date of death was March 11, 2020; is pending in the Circuit Court for Orange County, Florida, Probate Division, the address of which is 425 N. Orange Avenue, Orlando, Florida 32801. The names and addresses of the personal representative and the personal representative's attorney are set forth below.

All creditors of the decedent and other persons having claims or demands against decedent's estate, on whom a copy of this notice is required to be served must file their claims with this court ON OR BEFORE THE LATER OF 3 MONTHS AFTER THE TIME OF THE FIRST PUBLICATION OF THIS NOTICE OR 30 DAYS AFTER THE DATE OF SERVICE OF A COPY OF THIS NOTICE ON THEM.

All other creditors of the decedent and other persons having claims or demands against decedent's estate must file their claims with this court WITHIN 3 MONTHS AFTER THE DATE OF THIS NOTICE.

ALL CLAIMS NOT FILED WITHIN THE TIME PERIODS SET FORTH IN FLORIDA STATUTES SECTION 733.702 WILL BE FOREVER BARRED.

NOTWITHSTANDING THE TIME PERIOD SET FORTH ABOVE, ANY CLAIM FILED TWO (2) YEARS OR MORE AFTER THE DECEDENT'S DATE OF DEATH IS BARRED.

The date of first publication of this notice is: September 17, 2020.

/s/ John N. Puder
John N. Puder
Personal Representative
116 Kennison Drive
Orlando, Florida 32801:
/s/ Robert W. Morrison, Esq.
Robert W. Morrison, Esq.
Attorney for Personal Representative
Email: bob@bobmorrisonlaw.com
Secondary Email:
kemosabeetontol@gmail.com
Florida Bar No. 299863
Robert W. Morrison, P.A.
P.O. Box 9405 18
Maitland, Florida 32794
Telephone: 407-622-5874
September 17, 24, 2020 20-03609W

SECOND INSERTION

NOTICE TO CREDITORS
IN THE CIRCUIT COURT IN AND
FOR ORANGE COUNTY, FLORIDA
File No. 2020-CP-002293-O
PROBATE DIVISION
IN RE: ESTATE OF
TIMOTHY MARTIN CROWE
Deceased.

The administration of the estate of TIMOTHY MARTIN CROWE, deceased, (Decedent), whose date of death was July 18, 2020, is pending in the Circuit Court for Orange County, Florida, Probate Division, the address of which is 425 N. Orange Avenue, Orlando, Florida 32801. The names and addresses of the Personal Representative and the Personal Representative's attorney are set forth below.

All creditors of the Decedent and other persons having claims or demands against Decedent's estate on whom a copy of this notice is required to be served must file their claims with this court ON OR BEFORE THE LATER OF 3 MONTHS AFTER THE TIME OF THE FIRST PUBLICATION OF THIS NOTICE OR 30 DAYS AFTER THE DATE OF SERVICE OF A COPY OF THIS NOTICE ON THEM.

All other creditors of the Decedent and other persons having claims or demands against Decedent's estate must file their claims with this court WITHIN 3 MONTHS AFTER THE DATE OF THE FIRST PUBLICATION OF THIS NOTICE.

ALL CLAIMS NOT FILED WITHIN THE TIME PERIODS SET FORTH IN FLORIDA STATUTES SECTION 733.702 WILL BE FOREVER BARRED.

NOTWITHSTANDING THE TIME PERIODS SET FORTH ABOVE, ANY CLAIM FILED TWO (2) YEARS OR MORE AFTER THE DECEDENT'S DATE OF DEATH IS BARRED.

The date of first publication of this notice is September 17, 2020.

Personal Representative:
Timothy Martin Crowe, Jr.
321 Pennsylvania Ave
Ocoee, Florida 34761
Attorney for Personal Representative:
Ginger R. Lore, Attorney at Law
Attorney for Timothy Martin Crowe, Jr
Florida Bar Number: 643955
Law Offices of Ginger R. Lore, P.A.
20 S. Main Street, Suite 280
Winter Garden, FL 34787
Telephone: (407) 654-7028
Fax: (407) 641-9143
E-Mail: ginger@gingerlore.com
Secondary E-Mail:
eservice@gingerlore.com
September 17, 24, 2020 20-03612W

SECOND INSERTION

NOTICE TO CREDITORS
(Summary Administration)
IN THE CIRCUIT COURT FOR
ORANGE COUNTY, FLORIDA
PROBATE DIVISION
File No. 2020-CP-001444-O
Division Probate
IN RE: ESTATE OF
RAYMOND GARCIA,
Deceased.

TO ALL PERSONS HAVING CLAIMS OR DEMANDS AGAINST THE ABOVE ESTATE:

You are hereby notified that an Order of Summary Administration has been entered in the estate of Raymond Garcia, deceased, File Number 2020-CP-001444-O, by the Circuit Court for Orange County, Florida, Probate Division, the address of which is Orange County Probate Court, 425 N. Orange Ave. #340, Orlando, Florida 32801; that the decedent's date of death was March 1, 2020; that the total value of the estate is tangible and intangible personal property with an approximate value of less than \$75,000 and that the names and addresses of those to whom it has been assigned by such order are:

Name Address
Lillian Garcia, Trustee u/t/a dated 12/18/08, as amended and restated 6355 Cartmel Lane, Windermere, FL 34786

ALL INTERESTED PERSONS ARE NOTIFIED THAT:

All creditors of the estate of the Decedent and persons having claims or demands against the estate of the Decedent other than those for whom provision for full payment was made in the Order of Summary Administration must file their claims with this court WITHIN THE TIME PERIODS SET FORTH IN FLORIDA STATUTES SECTION 733.702. ALL CLAIMS AND DEMANDS NOT SO FILED WILL BE FOREVER BARRED. NOTWITHSTANDING ANY OTHER APPLICABLE TIME PERIOD, ANY CLAIM FILED TWO (2) YEARS OR MORE AFTER THE DECEDENT'S DATE OF DEATH IS BARRED.

The date of first publication of this Notice is September 17, 2020.

Person Giving Notice:
Lillian Garcia, Trustee
6355 Cartmel Lane
Windermere, FL 34786
Attorney for Person Giving Notice:
Michael A. Schmidt
Florida Bar No. 1010417
GALBRAITH, PLLC
9045 Strada Stell Court, Suite 106
Naples, FL 34109-4438
Telephone: (239) 325-5582
Email: mschmidt@galbraith.law
September 17, 24, 2020 20-03656W

SECOND INSERTION

NOTICE TO CREDITORS
IN THE CIRCUIT COURT FOR
ORANGE COUNTY, FLORIDA
PROBATE DIVISION
File No. 2020-CP-001929
IN RE: ESTATE OF
MARIANNA KIRKPATRICK
REEVES,
Deceased.

The administration of the estate of MARIANNA KIRKPATRICK REEVES, deceased, whose date of death was May 27, 2020, and whose social security number is XXX-XX-0888, is pending in the Circuit Court for Orange County, Florida, Probate Division, the address of which is 425 N. Orange Avenue, Orlando, Florida 32801. The names and addresses of the personal representative and the personal representative's attorney are set forth below.

All creditors of the decedent and other persons having claims or demands against decedent's estate on whom a copy of this notice is required to be served must file their claims with this court WITHIN THE LATER OF 3 MONTHS AFTER THE TIME OF THE FIRST PUBLICATION OF THIS NOTICE OR 30 DAYS AFTER THE DATE OF SERVICE OF A COPY OF THIS NOTICE ON THEM.

All other creditors of the decedent and other persons having claims or demands against decedent's estate must file their claims with this court WITHIN 3 MONTHS AFTER THE DATE OF THE FIRST PUBLICATION OF THIS NOTICE.

ALL CLAIMS NOT FILED WITHIN THE TIME PERIODS SET FORTH IN SECTION 733.702 OF THE FLORIDA PROBATE CODE WILL BE FOREVER BARRED.

NOTWITHSTANDING THE TIME PERIODS SET FORTH ABOVE, ANY CLAIM FILED TWO (2) YEARS OR MORE AFTER THE DECEDENT'S DATE OF DEATH IS BARRED.

The date of first publication of this notice is September 17, 2020.

Personal Representative:
John Todd Reeves
36 Jefferson Lane
Bedford, NY 10506
Attorney for Personal Representative:
Anthony J. Scaletta, Esq., Attorney
Florida Bar No. 058246
The Scaletta Law Firm, PLLC
618 E. South Street, Suite 110
Orlando, Florida 32801
Telephone: (407) 377-4226
September 17, 24, 2020 20-03611W

SECOND INSERTION

NOTICE TO CREDITORS
IN THE CIRCUIT COURT, NINTH
JUDICIAL CIRCUIT, IN AND FOR
ORANGE COUNTY, FLORIDA
PROBATE DIVISION 1
CASE NO.: 2020-CP-2346
IN RE: ESTATE OF
JEFFREY THOMAS MELLER,
Deceased.

TO: ALL PERSONS HAVING CLAIMS OR DEMANDS AGAINST THE ABOVE ESTATE:

You are hereby notified that a Petition for Administration has been filed in the ESTATE OF JEFFREY THOMAS MELLER, deceased, whose date of death was August 22, 2020, and is pending under Case No. 2020-CP-2346 in the Circuit Court for Orange County, Florida, Probate division, the address of which is 425 S. Orange Avenue, Orlando, Florida 32801; that the total cash value of the Estate is in excess of \$75,000.00 and that the name and address of the Personal Representative is:

Catalina Marin Aranguren
2521 Wyndam Bay Place
Apopka, FL 32703-1625

ALL INTERESTED PERSONS ARE NOTIFIED THAT:

All creditors of the decedent and other persons having claims or demands against decedent's estate, including unmatured, contingent or unliquidated claims, on whom a copy of this notice is served within three months after the date of the first publication of this notice must file their claims with this Court WITHIN THE LATER OF THREE MONTHS AFTER THE DATE OF THE FIRST PUBLICATION OF THIS NOTICE OR THIRTY DAYS AFTER THE DATE OF SERVICE OF A COPY OF THIS NOTICE ON THEM.

All other creditors of the decedent and persons having claims or demands against the Estate of the decedent, including unmatured, contingent or unliquidated claim, must file their claims with this court WITHIN THREE MONTHS AFTER THE DATE OF THE FIRST PUBLICATION OF THIS NOTICE.

ALL CLAIMS AND DEMANDS NOT SO FILED WITH BE FOREVER BARRED. NOTWITHSTANDING THAT TIME PERIOD SET FORTH ABOVE, ANY CLAIM FILED TWO (2) YEARS OR MORE AFTER THE DECEDENT'S DATE OF DEATH IS BARRED.

The date of the first publication of this Notice is September 17, 2020.

BLAIR D. SCHEMER
Attorney for Personal Representative
BERNARD & SCHEMER, P.A.
By: **/s/ Blair D. Schemer**
BLAIR D. SCHEMER
480 Busch Drive
Jacksonville, Florida 32218
Florida Bar No. 60598
904-751-6980
E-mail: blair@bernardlaw.net
September 17, 24, 2020 20-03614W

SECOND INSERTION

NOTICE TO CREDITORS
IN THE CIRCUIT COURT OF THE
NINTH JUDICIAL CIRCUIT IN AND
FOR ORANGE COUNTY, FLORIDA
Case No.: 2020-CP-2229
Probate Division
IN RE: ESTATE OF
MARLENE G. HENDRIX,
Deceased.

The administration of the estate of MARLENE G. HENDRIX, deceased, is pending in the Circuit Court for Orange County, Florida, Probate Division, the address of which is 425 N. Orange Avenue Orlando, FL 32801. The names and addresses of the personal representative and the personal representative's attorney are set forth below.

All creditors of the decedent and other persons having claims or demands against decedent's estate on whom a copy of this notice is required to be served must file their claims with this court WITHIN THE LATER OF 3 MONTHS AFTER THE TIME OF THE FIRST PUBLICATION OF THIS NOTICE OR 30 DAYS AFTER THE DATE OF SERVICE OF A COPY OF THIS NOTICE ON THEM.

All other creditors of the decedent and other persons having claims or demands against decedent's estate must file their claims with this court WITHIN 3 MONTHS AFTER THE DATE OF THE FIRST PUBLICATION OF THIS NOTICE.

ALL CLAIMS NOT FILED WITHIN THE TIME PERIODS SET FORTH IN SECTION 733.702 OF THE FLORIDA PROBATE CODE WILL BE FOREVER BARRED.

NOTWITHSTANDING THE TIME PERIODS SET FORTH ABOVE, ANY CLAIM FILED TWO (2) YEARS OR MORE AFTER THE DECEDENT'S DATE OF DEATH IS BARRED.

The date of first publication of this notice is September 17, 2020.

DAVID SCHMIDT
Petitioner
/s/: Amy N. Adams
AMY ADAMS
Attorney for Personal Representative
Florida Bar No. 95868
2281 Lee Road, Suite 102
Winter Park, FL 32789
Phone: 407.270.3724
Email: Amy@JoshAdamsLaw.com
September 17, 24, 2020 20-03652W

SECOND INSERTION

RE-NOTICE OF SALE
IN THE CIRCUIT COURT OF THE
NINTH JUDICIAL CIRCUIT IN AND
FOR ORANGE COUNTY, FLORIDA
CASE NO: 2016 CA 009298 O
WILMINGTON SAVINGS FUND
SOCIETY, FSB, d/b/a CHRISTIANA
TRUST AS OWNER TRUSTEE
OF THE RESIDENTIAL CREDIT
OPPORTUNITIES TRUST III, as
substituted Plaintiff for Bayview
Loan Servicing, LLC,
Plaintiff, vs.
LEONORA SHEA; et al.,
Defendants.

NOTICE IS HEREBY GIVEN pursuant to a Final Judgment of Foreclosure dated March 10, 2020, entered in Civil Case No. 2016- CA-009298-O of the Circuit Court of the 9th Judicial Circuit in and for Orange County, Florida, wherein WILMINGTON SAVINGS FUND SOCIETY, FSB, d/b/a CHRISTIANA TRUST AS OWNER TRUSTEE OF THE RESIDENTIAL CREDIT OPPORTUNITIES TRUST III, is Plaintiff and LEONORA SHEA; et al., are Defendant(s).

The Clerk, Tiffany Moore Russell, of the Circuit Court will sell to the highest bidder for cash, online at www.myorangelock.realforeclose.com at 11:00 A.M. o'clock a.m. on October 15, 2020, on the following described property as set forth in said Final Judgment, to wit:

CONDOMINIUM UNIT 105,
BUILDING 11 PHASE 1
OASIS COVE I AT LAKE-
SIDE VILLAGE, TOGETHER
WITH AN UNDIVIDED INTEREST IN THE COMMON ELEMENTS, ACCORDING TO THE DECLARATION OF CONDOMINIUM THEREOF RECORDED IN OFFICIAL RECORD BOOK 9461, PAGE 27, AS AMENDED FROM TIME TO TIME, OF THE PUBLIC RECORDS OF ORANGE COUNTY, FLORIDA.
Property Address: 14153 Oasis Cove Blvd, Unit 105, Windermere, Florida 34786

Any person claiming an interest in the surplus from the sale, if any, other than the property owner as of the date of the lis pendens must file a claim before the clerk reports the surplus as unclaimed. The Court, in its discretion, may enlarge the time of the sale. Notice of the changed time of sale shall be published as provided herein.

DATED this 11th day of September, 2020.

BY: **/s/ Matthew B. Leider**
MATTHEW B. LEIDER
FLORIDA BAR NO. 84424
LAW OFFICES OF MANDEL,
MANGANELLI & LEIDER, P.A.
Attorneys for Plaintiff
1900 N.W. Corporate Blvd.,
Ste. 305W
Boca Raton, FL 33431
Telephone: (561) 826-1740
Facsimile: (561) 826-1741
servicesmandel@gmail.com
September 17, 24, 2020 20-03606W

SECOND INSERTION

NOTICE TO CREDITORS
IN THE CIRCUIT COURT FOR
ORANGE COUNTY, FLORIDA
PROBATE DIVISION
File No. 2020-CP-2126 O
IN RE: ESTATE OF
RALPH OSCAR RIVERA
Deceased.

The administration of the estate of Ralph Oscar Rivera, deceased, File Number 2020-CP-2126-O is pending in the Circuit Court for Orange County, Florida, Probate Division, the address of which is 425 N Orange Avenue, Orlando, Florida 32801. The name and address of the Personal Representative and of the Personal Representative's attorney are set forth below.

All interested persons are required to file with the Court WITHIN THREE CALENDAR MONTHS FROM THE DATE OF THE FIRST PUBLICATION OF THIS NOTICE: (1) all claims against the estate and (2) any objection by an interested person to whom notice was mailed that challenges the validity of the will, the qualifications of the personal representative, venue or jurisdiction of the Court, WITHIN THE LATER OF THREE MONTHS AFTER FIRST PUBLICATION OF THIS NOTICE OR THIRTY DAYS AFTER THE DATE OF SERVICE OF A COPY OF THIS NOTICE ON THE OBJECTING PERSON.

ALL CLAIMS AND DEMANDS NOT SO FILED WILL BE FOREVER BARRED.

The date of first publication of this notice to creditors is September 17, 2020.

EVERLYN BURDICK
Personal Representative
W E Windermere, JR. Attorney
5546 Lake Howell Road
Winter Park, FL 32792
Telephone: (407) 628-4040
Florida Bar No. 0116626
September 17, 24, 2020 20-03613W

ORANGE COUNTY SUBSEQUENT INSERTIONS

SECOND INSERTION

NOTICE OF APPLICATION
FOR TAX DEED

NOTICE IS HEREBY GIVEN that IDE TECHNOLOGIES INC the holder of the following certificate has filed said certificate for a TAX DEED to be issued thereon. The Certificate number and year of issuance, the description of the property, and the names in which it was assessed are as follows:

CERTIFICATE NUMBER: 2018-7168

YEAR OF ISSUANCE: 2018

DESCRIPTION OF PROPERTY:
CAMPUS VIEW Q/107 LOT 66

PARCEL ID # 34-21-29-1144-00-660

Name in which assessed:
MELODY Y LANE

ALL of said property being in the County of Orange, State of Florida. Unless such certificate shall be redeemed according to law, the property described in such certificate will be sold to the highest bidder online at www.orange.realtaxdeed.com scheduled to begin at 10:00 a.m. ET, Oct 29, 2020.

Dated: Sep 10, 2020
Phil Diamond
County Comptroller
Orange County, Florida
By: M Hildebrandt
Deputy Comptroller
Sep. 17, 24; Oct. 1, 8, 2020

20-03517W

SECOND INSERTION

NOTICE OF APPLICATION
FOR TAX DEED

NOTICE IS HEREBY GIVEN that JESSE M POWELL (A MINOR) FUTMA-ROBERT E POWELL CUST FOR the holder of the following certificate has filed said certificate for a TAX DEED to be issued thereon. The Certificate number and year of issuance, the description of the property, and the names in which it was assessed are as follows:

CERTIFICATE NUMBER: 2018-1786

YEAR OF ISSUANCE: 2018

DESCRIPTION OF PROPERTY:
GREENBROOK VILLAS AT ERROL ESTATES 1 3854/1905 UNIT 1154 BLDG 13

PARCEL ID # 32-20-28-3215-01-154

Name in which assessed:
CARLA PRYOR

ALL of said property being in the County of Orange, State of Florida. Unless such certificate shall be redeemed according to law, the property described in such certificate will be sold to the highest bidder online at www.orange.realtaxdeed.com scheduled to begin at 10:00 a.m. ET, Oct 29, 2020.

Dated: Sep 10, 2020
Phil Diamond
County Comptroller
Orange County, Florida
By: M Hildebrandt
Deputy Comptroller
Sep. 17, 24; Oct. 1, 8, 2020

20-03507W

SECOND INSERTION

NOTICE OF APPLICATION
FOR TAX DEED

NOTICE IS HEREBY GIVEN that IDE TECHNOLOGIES INC the holder of the following certificate has filed said certificate for a TAX DEED to be issued thereon. The Certificate number and year of issuance, the description of the property, and the names in which it was assessed are as follows:

CERTIFICATE NUMBER: 2018-2165

YEAR OF ISSUANCE: 2018

DESCRIPTION OF PROPERTY:
TOWN OF APOPKA A/109 LOT 18 BLK H

PARCEL ID # 09-21-28-0196-80-180

Name in which assessed:
CARING HANDS SERVICE

ALL of said property being in the County of Orange, State of Florida. Unless such certificate shall be redeemed according to law, the property described in such certificate will be sold to the highest bidder online at www.orange.realtaxdeed.com scheduled to begin at 10:00 a.m. ET, Oct 29, 2020.

Dated: Sep 10, 2020
Phil Diamond
County Comptroller
Orange County, Florida
By: M Hildebrandt
Deputy Comptroller
Sep. 17, 24; Oct. 1, 8, 2020

20-03508W

SECOND INSERTION

NOTICE OF APPLICATION
FOR TAX DEED

NOTICE IS HEREBY GIVEN that JESSE M POWELL (A MINOR) FUTMA-ROBERT E POWELL CUST FOR the holder of the following certificate has filed said certificate for a TAX DEED to be issued thereon. The Certificate number and year of issuance, the description of the property, and the names in which it was assessed are as follows:

CERTIFICATE NUMBER: 2018-2486

YEAR OF ISSUANCE: 2018

DESCRIPTION OF PROPERTY:
FAIRFIELD X/65 LOT 4 BLK C

PARCEL ID # 14-21-28-2590-03-040

Name in which assessed:
PREFERRED TRUST CO CUSTODIAN

ALL of said property being in the County of Orange, State of Florida. Unless such certificate shall be redeemed according to law, the property described in such certificate will be sold to the highest bidder online at www.orange.realtaxdeed.com scheduled to begin at 10:00 a.m. ET, Oct 29, 2020.

Dated: Sep 10, 2020
Phil Diamond
County Comptroller
Orange County, Florida
By: M Hildebrandt
Deputy Comptroller
Sep. 17, 24; Oct. 1, 8, 2020

20-03509W

SECOND INSERTION

NOTICE OF APPLICATION
FOR TAX DEED

NOTICE IS HEREBY GIVEN that JESSE M POWELL (A MINOR) FUTMA-ROBERT E POWELL CUST FOR the holder of the following certificate has filed said certificate for a TAX DEED to be issued thereon. The Certificate number and year of issuance, the description of the property, and the names in which it was assessed are as follows:

CERTIFICATE NUMBER: 2018-4272

YEAR OF ISSUANCE: 2018

DESCRIPTION OF PROPERTY:
LAKE SHERWOOD HILLS PHASE 3 UNIT 1 PB 13/2 LOT 5-C

PARCEL ID # 22-22-28-4760-05-031

Name in which assessed:
PROVIDENT TRUST GROUP LLC FBO

ALL of said property being in the County of Orange, State of Florida. Unless such certificate shall be redeemed according to law, the property described in such certificate will be sold to the highest bidder online at www.orange.realtaxdeed.com scheduled to begin at 10:00 a.m. ET, Oct 29, 2020.

Dated: Sep 10, 2020
Phil Diamond
County Comptroller
Orange County, Florida
By: M Hildebrandt
Deputy Comptroller
Sep. 17, 24; Oct. 1, 8, 2020

20-03510W

SECOND INSERTION

NOTICE OF APPLICATION
FOR TAX DEED

NOTICE IS HEREBY GIVEN that FIG FL18 LLC the holder of the following certificate has filed said certificate for a TAX DEED to be issued thereon. The Certificate number and year of issuance, the description of the property, and the names in which it was assessed are as follows:

CERTIFICATE NUMBER: 2018-4696

YEAR OF ISSUANCE: 2018

DESCRIPTION OF PROPERTY:
PARK RIDGE O/100 LOTS 30 & 31 BLK 18 & E1/2 OF VAC ALLEY ON W SEE 3913/2388

PARCEL ID # 28-22-28-6689-18-300

Name in which assessed:
4 LIVING HOMES LLC

ALL of said property being in the County of Orange, State of Florida. Unless such certificate shall be redeemed according to law, the property described in such certificate will be sold to the highest bidder online at www.orange.realtaxdeed.com scheduled to begin at 10:00 a.m. ET, Oct 29, 2020.

Dated: Sep 10, 2020
Phil Diamond
County Comptroller
Orange County, Florida
By: M Hildebrandt
Deputy Comptroller
Sep. 17, 24; Oct. 1, 8, 2020

20-03511W

LV10181

**OFFICIAL
COURT
HOUSE
WEBSITES:**

MANATEE COUNTY:
manateeclerk.com

SARASOTA COUNTY:
sarasotaclerk.com

CHARLOTTE COUNTY:
charlotte.realforeclose.com

LEE COUNTY:
leeclerk.org

COLLIER COUNTY:
collierclerk.com

HILLSBOROUGH COUNTY:
hillsclerk.com

PASCO COUNTY:
pasco.realforeclose.com

PINELLAS COUNTY:
pinellasclerk.org

POLK COUNTY:
polkcountyclerk.net

ORANGE COUNTY:
myorangeclerk.com

SECOND INSERTION

NOTICE OF APPLICATION
FOR TAX DEED

NOTICE IS HEREBY GIVEN that IDE TECHNOLOGIES INC the holder of the following certificate has filed said certificate for a TAX DEED to be issued thereon. The Certificate number and year of issuance, the description of the property, and the names in which it was assessed are as follows:

CERTIFICATE NUMBER: 2018-6428

YEAR OF ISSUANCE: 2018

DESCRIPTION OF PROPERTY:
WILLIS R MUNGERS LAND SUB E/23 THE SW1/4 OF TR 97

PARCEL ID # 25-24-28-5844-00-971

Name in which assessed:
HUBERT R EARLEY, THORPE EARLEY

ALL of said property being in the County of Orange, State of Florida. Unless such certificate shall be redeemed according to law, the property described in such certificate will be sold to the highest bidder online at www.orange.realtaxdeed.com scheduled to begin at 10:00 a.m. ET, Oct 29, 2020.

Dated: Sep 10, 2020
Phil Diamond
County Comptroller
Orange County, Florida
By: M Hildebrandt
Deputy Comptroller
Sep. 17, 24; Oct. 1, 8, 2020

20-03512W

SECOND INSERTION

NOTICE OF APPLICATION
FOR TAX DEED

NOTICE IS HEREBY GIVEN that IDE TECHNOLOGIES INC the holder of the following certificate has filed said certificate for a TAX DEED to be issued thereon. The Certificate number and year of issuance, the description of the property, and the names in which it was assessed are as follows:

CERTIFICATE NUMBER: 2018-6429

YEAR OF ISSUANCE: 2018

DESCRIPTION OF PROPERTY:
WILLIS R MUNGERS LAND SUB E/23 THE SE1/4 OF LOT 98

PARCEL ID # 25-24-28-5844-01-003

Name in which assessed:
HUBERT R EARLEY, THORPE EARLEY

ALL of said property being in the County of Orange, State of Florida. Unless such certificate shall be redeemed according to law, the property described in such certificate will be sold to the highest bidder online at www.orange.realtaxdeed.com scheduled to begin at 10:00 a.m. ET, Oct 29, 2020.

Dated: Sep 10, 2020
Phil Diamond
County Comptroller
Orange County, Florida
By: M Hildebrandt
Deputy Comptroller
Sep. 17, 24; Oct. 1, 8, 2020

20-03513W

SECOND INSERTION

NOTICE OF APPLICATION
FOR TAX DEED

NOTICE IS HEREBY GIVEN that IDE TECHNOLOGIES INC the holder of the following certificate has filed said certificate for a TAX DEED to be issued thereon. The Certificate number and year of issuance, the description of the property, and the names in which it was assessed are as follows:

CERTIFICATE NUMBER: 2018-6432

YEAR OF ISSUANCE: 2018

DESCRIPTION OF PROPERTY:
WILLIS R MUNGERS LAND SUB E/23 THE NE1/4 OF TR 100

PARCEL ID # 25-24-28-5844-01-003

Name in which assessed:
HUBERT R EARLEY, THORPE EARLEY

ALL of said property being in the County of Orange, State of Florida. Unless such certificate shall be redeemed according to law, the property described in such certificate will be sold to the highest bidder online at www.orange.realtaxdeed.com scheduled to begin at 10:00 a.m. ET, Oct 29, 2020.

Dated: Sep 10, 2020
Phil Diamond
County Comptroller
Orange County, Florida
By: M Hildebrandt
Deputy Comptroller
Sep. 17, 24; Oct. 1, 8, 2020

20-03514W

SECOND INSERTION

NOTICE OF APPLICATION
FOR TAX DEED

NOTICE IS HEREBY GIVEN that FIG FL18 LLC the holder of the following certificate has filed said certificate for a TAX DEED to be issued thereon. The Certificate number and year of issuance, the description of the property, and the names in which it was assessed are as follows:

CERTIFICATE NUMBER: 2018-6811

YEAR OF ISSUANCE: 2018

DESCRIPTION OF PROPERTY:
MAGNOLIA COURT CONDOMINIUM 8469/2032 UNIT B BLDG 15

PARCEL ID # 28-21-29-5429-15-020

Name in which assessed:
BERNARD WOODSON JR, KELLY ALEY

ALL of said property being in the County of Orange, State of Florida. Unless such certificate shall be redeemed according to law, the property described in such certificate will be sold to the highest bidder online at www.orange.realtaxdeed.com scheduled to begin at 10:00 a.m. ET, Oct 29, 2020.

Dated: Sep 10, 2020
Phil Diamond
County Comptroller
Orange County, Florida
By: M Hildebrandt
Deputy Comptroller
Sep. 17, 24; Oct. 1, 8, 2020

20-03515W

SECOND INSERTION

NOTICE OF APPLICATION
FOR TAX DEED

NOTICE IS HEREBY GIVEN that IDE TECHNOLOGIES INC the holder of the following certificate has filed said certificate for a TAX DEED to be issued thereon. The Certificate number and year of issuance, the description of the property, and the names in which it was assessed are as follows:

CERTIFICATE NUMBER: 2018-7167

YEAR OF ISSUANCE: 2018

DESCRIPTION OF PROPERTY:
CAMPUS VIEW Q/107 LOT 65

PARCEL ID # 34-21-29-1144-00-650

Name in which assessed:
MICHAEL C LANE

ALL of said property being in the County of Orange, State of Florida. Unless such certificate shall be redeemed according to law, the property described in such certificate will be sold to the highest bidder online at www.orange.realtaxdeed.com scheduled to begin at 10:00 a.m. ET, Oct 29, 2020.

Dated: Sep 10, 2020
Phil Diamond
County Comptroller
Orange County, Florida
By: M Hildebrandt
Deputy Comptroller
Sep. 17, 24; Oct. 1, 8, 2020

20-03516W

SECOND INSERTION

NOTICE OF APPLICATION
FOR TAX DEED

NOTICE IS HEREBY GIVEN that MIKON FINANCIAL SERVICES INC AND OCEAN BANK the holder of the following certificate has filed said certificate for a TAX DEED to be issued thereon. The Certificate number and year of issuance, the description of the property, and the names in which it was assessed are as follows:

CERTIFICATE NUMBER: 2018-9361

YEAR OF ISSUANCE: 2018

DESCRIPTION OF PROPERTY:
W G WHITES SUB A/129 THE SW1/4 OF LOT 4 (LESS R/W ON S)

PARCEL ID # 26-22-29-9268-00-045

Name in which assessed:
GREENTREE 537 JACKSON ST LLC

ALL of said property being in the County of Orange, State of Florida. Unless such certificate shall be redeemed according to law, the property described in such certificate will be sold to the highest bidder online at www.orange.realtaxdeed.com scheduled to begin at 10:00 a.m. ET, Oct 29, 2020.

Dated: Sep 10, 2020
Phil Diamond
County Comptroller
Orange County, Florida
By: M Hildebrandt
Deputy Comptroller
Sep. 17, 24; Oct. 1, 8, 2020

20-03518W

SECOND INSERTION

NOTICE OF APPLICATION
FOR TAX DEED

NOTICE IS HEREBY GIVEN that FIG FL18 LLC the holder of the following certificate has filed said certificate for a TAX DEED to be issued thereon. The Certificate number and year of issuance, the description of the property, and the names in which it was assessed are as follows:

CERTIFICATE NUMBER: 2018-9476

YEAR OF ISSUANCE: 2018

DESCRIPTION OF PROPERTY:
WEST CENTRAL PARK REPLAT H/96 LOT 9 (LESS S 41 FT) BLK C

PARCEL ID # 27-22-29-9144-03-091

Name in which assessed:
DONALD ROLLINS, TANGELA ROLLINS

ALL of said property being in the County of Orange, State of Florida. Unless such certificate shall be redeemed according to law, the property described in such certificate will be sold to the highest bidder online at www.orange.realtaxdeed.com scheduled to begin at 10:00 a.m. ET, Oct 29, 2020.

Dated: Sep 10, 2020
Phil Diamond
County Comptroller
Orange County, Florida
By: M Hildebrandt
Deputy Comptroller
Sep. 17, 24; Oct. 1, 8, 2020

20-03519W

SECOND INSERTION

NOTICE OF APPLICATION
FOR TAX DEED

NOTICE IS HEREBY GIVEN that MIKON FINANCIAL SERVICES INC AND OCEAN BANK the holder of the following certificate has filed said certificate for a TAX DEED to be issued thereon. The Certificate number and year of issuance, the description of the property, and the names in which it was assessed are as follows:

CERTIFICATE NUMBER: 2018-11658

YEAR OF ISSUANCE: 2018

DESCRIPTION OF PROPERTY:
LEMON TREE SECTION 1 CONDO CB 3/141 BLDG 17 UNIT A

PARCEL ID # 09-23-29-5050-17-010

Name in which assessed:
SILVER RIVER MARKETING INC

ALL of said property being in the County of Orange, State of Florida. Unless such certificate shall be redeemed according to law, the property described in such certificate will be sold to the highest bidder online at www.orange.realtaxdeed.com scheduled to begin at 10:00 a.m. ET, Oct 29, 2020.

Dated: Sep 10, 2020
Phil Diamond
County Comptroller
Orange County, Florida
By: M Hildebrandt
Deputy Comptroller
Sep. 17, 24; Oct. 1, 8, 2020

20-03520W

SECOND INSERTION

NOTICE OF APPLICATION
FOR TAX DEED

NOTICE IS HEREBY GIVEN that FIG FL18 LLC the holder of the following certificate has filed said certificate for a TAX DEED to be issued thereon. The Certificate number and year of issuance, the description of the property, and the names in which it was assessed are as follows:

CERTIFICATE NUMBER: 2018-12041

YEAR OF ISSUANCE: 2018

DESCRIPTION OF PROPERTY:
LAKE TYLER CONDO CB 5/16 BLDG J UNIT 7

PARCEL ID # 15-23-29-4778-10-070

Name in which assessed:
LAKE TYLER CONDO ASSN INC

ALL of said property being in the County of Orange, State of Florida. Unless such certificate shall be redeemed according to law, the property described in such certificate will be sold to the highest bidder online at www.orange.realtaxdeed.com scheduled to begin at 10:00 a.m. ET, Oct 29, 2020.

Dated: Sep 10, 2020
Phil Diamond
County Comptroller
Orange County, Florida
By: M Hildebrandt
Deputy Comptroller
Sep. 17, 24; Oct. 1, 8, 2020

20-03521W

SECOND INSERTION

NOTICE OF APPLICATION
FOR TAX DEED

NOTICE IS HEREBY GIVEN that LIEGE TAX LIENS LLC the holder of the following certificate has filed said certificate for a TAX DEED to be issued thereon. The Certificate number and year of issuance, the description of the property, and the names in which it was assessed are as follows:

CERTIFICATE NUMBER: 2018-12046

YEAR OF ISSUANCE: 2018

DESCRIPTION OF PROPERTY:
MILLENNIUM PALMS CONDOMINIUM 9031/4073 UNIT 4711D

PARCEL ID # 15-23-29-5670-47-114

Name in which assessed:
JOSHUA SANTANA

ALL of said property being in the County of Orange, State of Florida. Unless such certificate shall be redeemed according to law, the property described in such certificate will be sold to the highest bidder online at www.orange.realtaxdeed.com scheduled to begin at 10:00 a.m. ET, Oct 29, 2020.

Dated: Sep 10, 2020
Phil Diamond
County Comptroller
Orange County, Florida
By: M Hildebrandt
Deputy Comptroller
Sep. 17, 24; Oct. 1, 8, 2020

20-03522W

Check out your notices on:
floridapublicnotices.com

**Business
Observer**

HOW TO PUBLISH YOUR LEGAL NOTICE IN THE BUSINESS OBSERVER

CALL 941-906-9386

and select the appropriate County name from the menu option
OR
e-mail legal@businessobserverfl.com

**Business
Observer**
LV10148

ORANGE COUNTY

SUBSEQUENT INSERTIONS

SECOND INSERTION

NOTICE OF APPLICATION FOR TAX DEED

NOTICE IS HEREBY GIVEN that MIKON FINANCIAL SERVICES INC AND OCEAN BANK the holder of the following certificate has filed said certificate for a TAX DEED to be issued thereon. The Certificate number and year of issuance, the description of the property, and the names in which it was assessed are as follows:

CERTIFICATE NUMBER:
2018-12064

YEAR OF ISSUANCE: 2018

DESCRIPTION OF PROPERTY:
MILLENNIUM PALMS
CONDOMINIUM 9031/4073
UNIT 4753D

PARCEL ID # 15-23-29-5670-47-534

Name in which assessed:
KARAM HAJ YAHYA

ALL of said property being in the County of Orange, State of Florida. Unless such certificate shall be redeemed according to law, the property described in such certificate will be sold to the highest bidder online at www.orange.realtaxdeed.com scheduled to begin at 10:00 a.m. ET, Oct 29, 2020.

Dated: Sep 10, 2020
Phil Diamond
County Comptroller
Orange County, Florida
By: M Hildebrandt
Deputy Comptroller
Sep. 17, 24; Oct. 1, 8, 2020

20-03523W

SECOND INSERTION

NOTICE OF APPLICATION FOR TAX DEED

NOTICE IS HEREBY GIVEN that FIG FL18 LLC the holder of the following certificate has filed said certificate for a TAX DEED to be issued thereon. The Certificate number and year of issuance, the description of the property, and the names in which it was assessed are as follows:

CERTIFICATE NUMBER:
2018-15083

YEAR OF ISSUANCE: 2018

DESCRIPTION OF PROPERTY:
COLONIAL GROVE ESTATES E/95
LOT 1 BLK A

PARCEL ID # 19-22-30-1512-01-010

Name in which assessed:
MARGARET A DAVIS

ALL of said property being in the County of Orange, State of Florida. Unless such certificate shall be redeemed according to law, the property described in such certificate will be sold to the highest bidder online at www.orange.realtaxdeed.com scheduled to begin at 10:00 a.m. ET, Oct 29, 2020.

Dated: Sep 10, 2020
Phil Diamond
County Comptroller
Orange County, Florida
By: M Hildebrandt
Deputy Comptroller
Sep. 17, 24; Oct. 1, 8, 2020

20-03529W

SECOND INSERTION

NOTICE OF APPLICATION FOR TAX DEED

NOTICE IS HEREBY GIVEN that LUKE R POWELL (A MINOR) FUTURE MAROBERT E POWELL CUST FOR the holder of the following certificate has filed said certificate for a TAX DEED to be issued thereon. The Certificate number and year of issuance, the description of the property, and the names in which it was assessed are as follows:

CERTIFICATE NUMBER: 2018-16813

YEAR OF ISSUANCE: 2018

DESCRIPTION OF PROPERTY:
VENETIAN PLACE CONDOMINIUM
8755/1712 UNIT 2217 BLDG 22

PARCEL ID # 10-23-30-8908-02-217

Name in which assessed:
ANG POH YEOW SAM

ALL of said property being in the County of Orange, State of Florida. Unless such certificate shall be redeemed according to law, the property described in such certificate will be sold to the highest bidder online at www.orange.realtaxdeed.com scheduled to begin at 10:00 a.m. ET, Oct 29, 2020.

Dated: Sep 10, 2020
Phil Diamond
County Comptroller
Orange County, Florida
By: M Hildebrandt
Deputy Comptroller
Sep. 17, 24; Oct. 1, 8, 2020

20-03535W

SECOND INSERTION

NOTICE OF APPLICATION FOR TAX DEED

NOTICE IS HEREBY GIVEN that FIG FL18 LLC the holder of the following certificate has filed said certificate for a TAX DEED to be issued thereon. The Certificate number and year of issuance, the description of the property, and the names in which it was assessed are as follows:

CERTIFICATE NUMBER: 2018-12072

YEAR OF ISSUANCE: 2018

DESCRIPTION OF PROPERTY:
MILLENNIUM PALMS
CONDOMINIUM 9031/4073
UNIT 4773A

PARCEL ID # 15-23-29-5670-47-731

Name in which assessed: FEBRIN LLC

ALL of said property being in the County of Orange, State of Florida. Unless such certificate shall be redeemed according to law, the property described in such certificate will be sold to the highest bidder online at www.orange.realtaxdeed.com scheduled to begin at 10:00 a.m. ET, Oct 29, 2020.

Dated: Sep 10, 2020
Phil Diamond
County Comptroller
Orange County, Florida
By: M Hildebrandt
Deputy Comptroller
Sep. 17, 24; Oct. 1, 8, 2020

20-03524W

SECOND INSERTION

NOTICE OF APPLICATION FOR TAX DEED

NOTICE IS HEREBY GIVEN that FLORIDA TAX CERTIFICATE FUND 1 MUNICIPAL TAX LLC the holder of the following certificate has filed said certificate for a TAX DEED to be issued thereon. The Certificate number and year of issuance, the description of the property, and the names in which it was assessed are as follows:

CERTIFICATE NUMBER: 2018-15231

YEAR OF ISSUANCE: 2018

DESCRIPTION OF PROPERTY: W1/2 OF SW1/4 OF SW1/4 OF SEC 22-22-30 (LESS N 30 FT THEREOF) & (LESS S 480 FT & E 60 FT THEREOF) & (LESS W 180 FT OF N 50 FT OF S 530 FT THEREOF) & (LESS W 150 FT OF E 210 FT OF N 130 FT OF S 610 FT THEREOF) & (LESS W 150 FT OF E 210 FT OF N 280 FT) & (LESS R/W FOR STATE RD NO 526) & (LESS N 150 FT OF S 930 FT OF W 180 FT) & (LESS R/W PER 8167/4623)

PARCEL ID # 22-22-30-0000-00-071

Name in which assessed:
ROBERT TRAN LLC

ALL of said property being in the County of Orange, State of Florida. Unless such certificate shall be redeemed according to law, the property described in such certificate will be sold to the highest bidder online at www.orange.realtaxdeed.com scheduled to begin at 10:00 a.m. ET, Oct 29, 2020.

Dated: Sep 10, 2020
Phil Diamond
County Comptroller
Orange County, Florida
By: M Hildebrandt
Deputy Comptroller
Sep. 17, 24; Oct. 1, 8, 2020

20-03530W

SECOND INSERTION

NOTICE OF APPLICATION FOR TAX DEED

NOTICE IS HEREBY GIVEN that FIG FL18 LLC the holder of the following certificate has filed said certificate for a TAX DEED to be issued thereon. The Certificate number and year of issuance, the description of the property, and the names in which it was assessed are as follows:

CERTIFICATE NUMBER: 2018-17333

YEAR OF ISSUANCE: 2018

DESCRIPTION OF PROPERTY:
BRENTWOOD S/115 LOT 13

PARCEL ID # 23-23-30-0892-00-130

Name in which assessed:
MARTIN J COOK II

ALL of said property being in the County of Orange, State of Florida. Unless such certificate shall be redeemed according to law, the property described in such certificate will be sold to the highest bidder online at www.orange.realtaxdeed.com scheduled to begin at 10:00 a.m. ET, Oct 29, 2020.

Dated: Sep 10, 2020
Phil Diamond
County Comptroller
Orange County, Florida
By: M Hildebrandt
Deputy Comptroller
Sep. 17, 24; Oct. 1, 8, 2020

20-03536W

SECOND INSERTION

NOTICE OF APPLICATION FOR TAX DEED

NOTICE IS HEREBY GIVEN that FLORIDA TAX CERTIFICATE FUND 1 MUNICIPAL TAX LLC the holder of the following certificate has filed said certificate for a TAX DEED to be issued thereon. The Certificate number and year of issuance, the description of the property, and the names in which it was assessed are as follows:

CERTIFICATE NUMBER: 2018-13587

YEAR OF ISSUANCE: 2018

DESCRIPTION OF PROPERTY:
WINDMILL POINTE 8/137 LOT 311

PARCEL ID # 07-24-29-9359-03-110

Name in which assessed: DESMOND M KERINS, LORETTA A KERINS

ALL of said property being in the County of Orange, State of Florida. Unless such certificate shall be redeemed according to law, the property described in such certificate will be sold to the highest bidder online at www.orange.realtaxdeed.com scheduled to begin at 10:00 a.m. ET, Oct 29, 2020.

Dated: Sep 10, 2020
Phil Diamond
County Comptroller
Orange County, Florida
By: M Hildebrandt
Deputy Comptroller
Sep. 17, 24; Oct. 1, 8, 2020

20-03525W

SECOND INSERTION

NOTICE OF APPLICATION FOR TAX DEED

NOTICE IS HEREBY GIVEN that LIEGE TAX LIENS LLC is the holder of the following certificate has filed said certificate for a TAX DEED to be issued thereon. The Certificate number and year of issuance, the description of the property, and the names in which it was assessed are as follows:

CERTIFICATE NUMBER:
2018-15840

YEAR OF ISSUANCE: 2018

DESCRIPTION OF PROPERTY:
CANDLEWYCK VILLAGE 10/78 LOT 75A

PARCEL ID # 34-22-30-1163-00-750

Name in which assessed: PATRICIA ALESANDRA CURCOVEZKI

ALL of said property being in the County of Orange, State of Florida. Unless such certificate shall be redeemed according to law, the property described in such certificate will be sold to the highest bidder online at www.orange.realtaxdeed.com scheduled to begin at 10:00 a.m. ET, Oct 29, 2020.

Dated: Sep 10, 2020
Phil Diamond
County Comptroller
Orange County, Florida
By: M Hildebrandt
Deputy Comptroller
Sep. 17, 24; Oct. 1, 8, 2020

20-03531W

SECOND INSERTION

NOTICE OF APPLICATION FOR TAX DEED

NOTICE IS HEREBY GIVEN that FIG FL18 LLC the holder of the following certificate has filed said certificate for a TAX DEED to be issued thereon. The Certificate number and year of issuance, the description of the property, and the names in which it was assessed are as follows:

CERTIFICATE NUMBER: 2018-17338

YEAR OF ISSUANCE: 2018

DESCRIPTION OF PROPERTY:
BRENTWOOD S/115 LOT 45

PARCEL ID # 23-23-30-0892-00-450

Name in which assessed:
ARTHUR J FOUCAULT ESTATE

ALL of said property being in the County of Orange, State of Florida. Unless such certificate shall be redeemed according to law, the property described in such certificate will be sold to the highest bidder online at www.orange.realtaxdeed.com scheduled to begin at 10:00 a.m. ET, Oct 29, 2020.

Dated: Sep 10, 2020
Phil Diamond
County Comptroller
Orange County, Florida
By: M Hildebrandt
Deputy Comptroller
Sep. 17, 24; Oct. 1, 8, 2020

20-03537W

SECOND INSERTION

NOTICE OF APPLICATION FOR TAX DEED

NOTICE IS HEREBY GIVEN that MIKON FINANCIAL SERVICES INC AND OCEAN BANK the holder of the following certificate has filed said certificate for a TAX DEED to be issued thereon. The Certificate number and year of issuance, the description of the property, and the names in which it was assessed are as follows:

CERTIFICATE NUMBER:
2018-13643

YEAR OF ISSUANCE: 2018

DESCRIPTION OF PROPERTY:
HAWTHORNE VILLAGE
CONDOMINIUM 8611/3509
UNIT 1 BLDG 4

PARCEL ID # 10-24-29-3055-04-010

Name in which assessed:
SK ALL SERVICES LLC

ALL of said property being in the County of Orange, State of Florida. Unless such certificate shall be redeemed according to law, the property described in such certificate will be sold to the highest bidder online at www.orange.realtaxdeed.com scheduled to begin at 10:00 a.m. ET, Oct 29, 2020.

Dated: Sep 10, 2020
Phil Diamond
County Comptroller
Orange County, Florida
By: M Hildebrandt
Deputy Comptroller
Sep. 17, 24; Oct. 1, 8, 2020

20-03526W

SECOND INSERTION

NOTICE OF APPLICATION FOR TAX DEED

NOTICE IS HEREBY GIVEN that FIG FL18 LLC the holder of the following certificate has filed said certificate for a TAX DEED to be issued thereon. The Certificate number and year of issuance, the description of the property, and the names in which it was assessed are as follows:

CERTIFICATE NUMBER: 2018-15856

YEAR OF ISSUANCE: 2018

DESCRIPTION OF PROPERTY:
ENGELWOOD PARK UNIT 2 T/136
LOT 7 BLK 10

PARCEL ID # 34-22-30-2496-10-070

Name in which assessed:
JOSE E PADILLA

ALL of said property being in the County of Orange, State of Florida. Unless such certificate shall be redeemed according to law, the property described in such certificate will be sold to the highest bidder online at www.orange.realtaxdeed.com scheduled to begin at 10:00 a.m. ET, Oct 29, 2020.

Dated: Sep 10, 2020
Phil Diamond
County Comptroller
Orange County, Florida
By: M Hildebrandt
Deputy Comptroller
Sep. 17, 24; Oct. 1, 8, 2020

20-03532W

SECOND INSERTION

NOTICE OF APPLICATION FOR TAX DEED

NOTICE IS HEREBY GIVEN that FIG FL18 LLC the holder of the following certificate has filed said certificate for a TAX DEED to be issued thereon. The Certificate number and year of issuance, the description of the property, and the names in which it was assessed are as follows:

CERTIFICATE NUMBER: 2018-17413

YEAR OF ISSUANCE: 2018

DESCRIPTION OF PROPERTY:
VISTA LAKES VILLAGE N-14
(WARWICK) 61/20 LOT 40

PARCEL ID # 24-23-30-8987-00-400

Name in which assessed:
SAFI KONGOLO NDJIBU

ALL of said property being in the County of Orange, State of Florida. Unless such certificate shall be redeemed according to law, the property described in such certificate will be sold to the highest bidder online at www.orange.realtaxdeed.com scheduled to begin at 10:00 a.m. ET, Oct 29, 2020.

Dated: Sep 10, 2020
Phil Diamond
County Comptroller
Orange County, Florida
By: M Hildebrandt
Deputy Comptroller
Sep. 17, 24; Oct. 1, 8, 2020

20-03538W

SECOND INSERTION

NOTICE OF APPLICATION FOR TAX DEED

NOTICE IS HEREBY GIVEN that LIEGE TAX LIENS LLC is the holder of the following certificate has filed said certificate for a TAX DEED to be issued thereon. The Certificate number and year of issuance, the description of the property, and the names in which it was assessed are as follows:

CERTIFICATE NUMBER: 2018-14155

YEAR OF ISSUANCE: 2018

DESCRIPTION OF PROPERTY:
HUNTERS CREEK TRACT 511 &
HUNTERS VISTA BLVD PHASE 2
41/63 LOT 82

PARCEL ID # 30-24-29-3869-00-820

Name in which assessed:
MARCELO GRIEBLER

ALL of said property being in the County of Orange, State of Florida. Unless such certificate shall be redeemed according to law, the property described in such certificate will be sold to the highest bidder online at www.orange.realtaxdeed.com scheduled to begin at 10:00 a.m. ET, Oct 29, 2020.

Dated: Sep 10, 2020
Phil Diamond
County Comptroller
Orange County, Florida
By: M Hildebrandt
Deputy Comptroller
Sep. 17, 24; Oct. 1, 8, 2020

20-03527W

SECOND INSERTION

NOTICE OF APPLICATION FOR TAX DEED

NOTICE IS HEREBY GIVEN that LUKE R POWELL (A MINOR) FUTURE MAROBERT E POWELL CUST FOR the holder of the following certificate has filed said certificate for a TAX DEED to be issued thereon. The Certificate number and year of issuance, the description of the property, and the names in which it was assessed are as follows:

CERTIFICATE NUMBER: 2018-16238

YEAR OF ISSUANCE: 2018

DESCRIPTION OF PROPERTY:
REGISTRY AT MICHIGAN PARK
CONDOMINIUM 7941/2400 UNIT
1306

PARCEL ID # 04-23-30-7346-01-306

Name in which assessed: TOTAL HOMESTAR REAL ESTATE LLC

ALL of said property being in the County of Orange, State of Florida. Unless such certificate shall be redeemed according to law, the property described in such certificate will be sold to the highest bidder online at www.orange.realtaxdeed.com scheduled to begin at 10:00 a.m. ET, Oct 29, 2020.

Dated: Sep 10, 2020
Phil Diamond
County Comptroller
Orange County, Florida
By: M Hildebrandt
Deputy Comptroller
Sep. 17, 24; Oct. 1, 8, 2020

20-03533W

SECOND INSERTION

NOTICE OF APPLICATION FOR TAX DEED

NOTICE IS HEREBY GIVEN that FIG FL18 LLC the holder of the following certificate has filed said certificate for a TAX DEED to be issued thereon. The Certificate number and year of issuance, the description of the property, and the names in which it was assessed are as follows:

CERTIFICATE NUMBER: 2018-17830

YEAR OF ISSUANCE: 2018

DESCRIPTION OF PROPERTY:
AEIN SUB U/94 LOT 20 (LESS THE
E 300 FT)

PARCEL ID # 08-22-31-0028-00-200

Name in which assessed:
LUZ M VENERO

ALL of said property being in the County of Orange, State of Florida. Unless such certificate shall be redeemed according to law, the property described in such certificate will be sold to the highest bidder online at www.orange.realtaxdeed.com scheduled to begin at 10:00 a.m. ET, Oct 29, 2020.

Dated: Sep 10, 2020
Phil Diamond
County Comptroller
Orange County, Florida
By: M Hildebrandt
Deputy Comptroller
Sep. 17, 24; Oct. 1, 8, 2020

20-03539W

SECOND INSERTION

NOTICE OF APPLICATION FOR TAX DEED

NOTICE IS HEREBY GIVEN that FIG FL18 LLC the holder of the following certificate has filed said certificate for a TAX DEED to be issued thereon. The Certificate number and year of issuance, the description of the property, and the names in which it was assessed are as follows:

CERTIFICATE NUMBER:
2018-14990

YEAR OF ISSUANCE: 2018

DESCRIPTION OF PROPERTY:
SEMORAN CLUB CONDO CB 4/56
UNIT 35 BLDG C

PARCEL ID # 16-22-30-7800-03-350

Name in which assessed:
MICHAEL L BROWN

ALL of said property being in the County of Orange, State of Florida. Unless such certificate shall be redeemed according to law, the property described in such certificate will be sold to the highest bidder online at www.orange.realtaxdeed.com scheduled to begin at 10:00 a.m. ET, Oct 29, 2020.

Dated: Sep 10, 2020
Phil Diamond
County Comptroller
Orange County, Florida
By: M Hildebrandt
Deputy Comptroller
Sep. 17, 24; Oct. 1, 8, 2020

20-03528W

SECOND INSERTION

NOTICE OF APPLICATION FOR TAX DEED

NOTICE IS HEREBY GIVEN that FIG FL18 LLC the holder of the following certificate has filed said certificate for a TAX DEED to be issued thereon. The Certificate number and year of issuance, the description of the property, and the names in which it was assessed are as follows:

CERTIFICATE NUMBER:
2018-16486

YEAR OF ISSUANCE: 2018

DESCRIPTION OF PROPERTY:

ORANGE COUNTY

SUBSEQUENT INSERTIONS

FOURTH INSERTION

NOTICE OF APPLICATION FOR TAX DEED

NOTICE IS HEREBY GIVEN that FIG FL18 LLC the holder of the following certificate has filed said certificate for a TAX DEED to be issued thereon. The Certificate number and year of issuance, the description of the property, and the names in which it was assessed are as follows:

CERTIFICATE NUMBER: 2018-9522

YEAR OF ISSUANCE: 2018

DESCRIPTION OF PROPERTY: COTTAGE HILL SUB G/83 E 158.85 FT OF W 272 FT OF LOTS 9 & 10 BLK B (LESS PT TAKEN ON S FOR R/W PER 6265/3691)

PARCEL ID # 28-22-29-1764-02-093

Name in which assessed:
ISAAC D WILKES, MARGIE WILKES

ALL of said property being in the County of Orange, State of Florida. Unless such certificate shall be redeemed according to law, the property described in such certificate will be sold to the highest bidder online at www.orange.realtaxdeed.com scheduled to begin at 10:00 a.m. ET, Oct 15, 2020.

Dated: Aug 27, 2020
Phil Diamond
County Comptroller
Orange County, Florida
By: M Hildebrandt
Deputy Comptroller
September 3, 10, 17, 24, 2020
20-03125W

FOURTH INSERTION

NOTICE OF APPLICATION FOR TAX DEED

NOTICE IS HEREBY GIVEN that LIEGE TAX LIENS LLC 18 the holder of the following certificate has filed said certificate for a TAX DEED to be issued thereon. The Certificate number and year of issuance, the description of the property, and the names in which it was assessed are as follows:

CERTIFICATE NUMBER: 2018-9874_1

YEAR OF ISSUANCE: 2018

DESCRIPTION OF PROPERTY: L C COXS ADDITION R/42 LOTS 13 & 14 BLK D

PARCEL ID # 31-22-29-1800-04-140

Name in which assessed:
VERDIE LEE WATTS ESTATE

ALL of said property being in the County of Orange, State of Florida. Unless such certificate shall be redeemed according to law, the property described in such certificate will be sold to the highest bidder online at www.orange.realtaxdeed.com scheduled to begin at 10:00 a.m. ET, Oct 15, 2020.

Dated: Aug 27, 2020
Phil Diamond
County Comptroller
Orange County, Florida
By: M Hildebrandt
Deputy Comptroller
September 3, 10, 17, 24, 2020
20-03131W

FOURTH INSERTION

NOTICE OF APPLICATION FOR TAX DEED

NOTICE IS HEREBY GIVEN that FIG FL18 LLC the holder of the following certificate has filed said certificate for a TAX DEED to be issued thereon. The Certificate number and year of issuance, the description of the property, and the names in which it was assessed are as follows:

CERTIFICATE NUMBER: 2018-10880

YEAR OF ISSUANCE: 2018

DESCRIPTION OF PROPERTY: ANGEBILT ADDITION H/79 LOT 5 BLK 44

PARCEL ID # 03-23-29-0180-44-050

Name in which assessed:
US AMERIBANK

ALL of said property being in the County of Orange, State of Florida. Unless such certificate shall be redeemed according to law, the property described in such certificate will be sold to the highest bidder online at www.orange.realtaxdeed.com scheduled to begin at 10:00 a.m. ET, Oct 15, 2020.

Dated: Aug 27, 2020
Phil Diamond
County Comptroller
Orange County, Florida
By: M Hildebrandt
Deputy Comptroller
September 3, 10, 17, 24, 2020
20-03137W

FOURTH INSERTION

NOTICE OF APPLICATION FOR TAX DEED

NOTICE IS HEREBY GIVEN that FIG FL18 LLC the holder of the following certificate has filed said certificate for a TAX DEED to be issued thereon. The Certificate number and year of issuance, the description of the property, and the names in which it was assessed are as follows:

CERTIFICATE NUMBER: 2018-9623

YEAR OF ISSUANCE: 2018

DESCRIPTION OF PROPERTY: BEG SW COR OF NE1/4 TH E 473 FT S 165 FT E 842.54 FT N 165 FT W 442.54 FT N 310 FT N 76 DEG W 231.43 FT S 285 FT W 643 FT S 148 FT TO POB & (LESS S 148 FT OF W1/2 OF SW1/4 OF NE1/4) & (LESS 30 FT R/W ON W)

PARCEL ID # 29-22-29-0000-00-040

Name in which assessed:
SOUTHERN PROPERTY LLC

ALL of said property being in the County of Orange, State of Florida. Unless such certificate shall be redeemed according to law, the property described in such certificate will be sold to the highest bidder online at www.orange.realtaxdeed.com scheduled to begin at 10:00 a.m. ET, Oct 15, 2020.

Dated: Aug 27, 2020
Phil Diamond
County Comptroller
Orange County, Florida
By: M Hildebrandt
Deputy Comptroller
September 3, 10, 17, 24, 2020
20-03126W

FOURTH INSERTION

NOTICE OF APPLICATION FOR TAX DEED

NOTICE IS HEREBY GIVEN that FIG FL18 LLC the holder of the following certificate has filed said certificate for a TAX DEED to be issued thereon. The Certificate number and year of issuance, the description of the property, and the names in which it was assessed are as follows:

CERTIFICATE NUMBER: 2018-9884

YEAR OF ISSUANCE: 2018

DESCRIPTION OF PROPERTY: MALIBU GROVES SIXTH ADDITION 2/146 LOT 137

PARCEL ID # 31-22-29-1820-01-370

Name in which assessed:
LILLIE MAE MORRIS ESTATE

ALL of said property being in the County of Orange, State of Florida. Unless such certificate shall be redeemed according to law, the property described in such certificate will be sold to the highest bidder online at www.orange.realtaxdeed.com scheduled to begin at 10:00 a.m. ET, Oct 15, 2020.

Dated: Aug 27, 2020
Phil Diamond
County Comptroller
Orange County, Florida
By: M Hildebrandt
Deputy Comptroller
September 3, 10, 17, 24, 2020
20-03132W

FOURTH INSERTION

NOTICE OF APPLICATION FOR TAX DEED

NOTICE IS HEREBY GIVEN that FIG FL18 LLC the holder of the following certificate has filed said certificate for a TAX DEED to be issued thereon. The Certificate number and year of issuance, the description of the property, and the names in which it was assessed are as follows:

CERTIFICATE NUMBER: 2018-11159

YEAR OF ISSUANCE: 2018

DESCRIPTION OF PROPERTY: WASHINGTON SHORES 4TH ADDITION X/69 LOT 3 BLK D

PARCEL ID # 04-23-29-9021-04-030

Name in which assessed:
OPHELIA PRICE ESTATE, DELORES DIXON, MICHELLE R DIXON

ALL of said property being in the County of Orange, State of Florida. Unless such certificate shall be redeemed according to law, the property described in such certificate will be sold to the highest bidder online at www.orange.realtaxdeed.com scheduled to begin at 10:00 a.m. ET, Oct 15, 2020.

Dated: Aug 27, 2020
Phil Diamond
County Comptroller
Orange County, Florida
By: M Hildebrandt
Deputy Comptroller
September 3, 10, 17, 24, 2020
20-03138W

FOURTH INSERTION

NOTICE OF APPLICATION FOR TAX DEED

NOTICE IS HEREBY GIVEN that FIG FL18 LLC the holder of the following certificate has filed said certificate for a TAX DEED to be issued thereon. The Certificate number and year of issuance, the description of the property, and the names in which it was assessed are as follows:

CERTIFICATE NUMBER: 2018-9710

YEAR OF ISSUANCE: 2018

DESCRIPTION OF PROPERTY: OPAL GARDENS R/75 LOT 21

PARCEL ID # 29-22-29-6188-00-210

Name in which assessed:
ILENE WALWYN

ALL of said property being in the County of Orange, State of Florida. Unless such certificate shall be redeemed according to law, the property described in such certificate will be sold to the highest bidder online at www.orange.realtaxdeed.com scheduled to begin at 10:00 a.m. ET, Oct 15, 2020.

Dated: Aug 27, 2020
Phil Diamond
County Comptroller
Orange County, Florida
By: M Hildebrandt
Deputy Comptroller
September 3, 10, 17, 24, 2020
20-03127W

FOURTH INSERTION

NOTICE OF APPLICATION FOR TAX DEED

NOTICE IS HEREBY GIVEN that FIG FL18 LLC the holder of the following certificate has filed said certificate for a TAX DEED to be issued thereon. The Certificate number and year of issuance, the description of the property, and the names in which it was assessed are as follows:

CERTIFICATE NUMBER: 2018-10102

YEAR OF ISSUANCE: 2018

DESCRIPTION OF PROPERTY: WASHINGTON PARK SECTION ONE O/151 LOT 14 BLK 6

PARCEL ID # 32-22-29-9004-06-140

Name in which assessed:
LILLIE M PONDER

ALL of said property being in the County of Orange, State of Florida. Unless such certificate shall be redeemed according to law, the property described in such certificate will be sold to the highest bidder online at www.orange.realtaxdeed.com scheduled to begin at 10:00 a.m. ET, Oct 15, 2020.

Dated: Aug 27, 2020
Phil Diamond
County Comptroller
Orange County, Florida
By: M Hildebrandt
Deputy Comptroller
September 3, 10, 17, 24, 2020
20-03133W

FOURTH INSERTION

NOTICE OF APPLICATION FOR TAX DEED

NOTICE IS HEREBY GIVEN that LIEGE TAX LIENS LLC 18 the holder of the following certificate has filed said certificate for a TAX DEED to be issued thereon. The Certificate number and year of issuance, the description of the property, and the names in which it was assessed are as follows:

CERTIFICATE NUMBER: 2018-11355

YEAR OF ISSUANCE: 2018

DESCRIPTION OF PROPERTY: RICHMOND HEIGHTS NO 7 3/4 LOT 80

PARCEL ID # 05-23-29-7408-00-800

Name in which assessed:
IDA RAY DAVIS ESTATE

ALL of said property being in the County of Orange, State of Florida. Unless such certificate shall be redeemed according to law, the property described in such certificate will be sold to the highest bidder online at www.orange.realtaxdeed.com scheduled to begin at 10:00 a.m. ET, Oct 15, 2020.

Dated: Aug 27, 2020
Phil Diamond
County Comptroller
Orange County, Florida
By: M Hildebrandt
Deputy Comptroller
September 3, 10, 17, 24, 2020
20-03139W

FOURTH INSERTION

NOTICE OF APPLICATION FOR TAX DEED

NOTICE IS HEREBY GIVEN that FIG FL18 LLC the holder of the following certificate has filed said certificate for a TAX DEED to be issued thereon. The Certificate number and year of issuance, the description of the property, and the names in which it was assessed are as follows:

CERTIFICATE NUMBER: 2018-9750

YEAR OF ISSUANCE: 2018

DESCRIPTION OF PROPERTY: FLEMING HEIGHTS O/74 LOT 16 BLK B

PARCEL ID # 30-22-29-2744-02-160

Name in which assessed:
FERRAZ-SARTINI LLC

ALL of said property being in the County of Orange, State of Florida. Unless such certificate shall be redeemed according to law, the property described in such certificate will be sold to the highest bidder online at www.orange.realtaxdeed.com scheduled to begin at 10:00 a.m. ET, Oct 15, 2020.

Dated: Aug 27, 2020
Phil Diamond
County Comptroller
Orange County, Florida
By: M Hildebrandt
Deputy Comptroller
September 3, 10, 17, 24, 2020
20-03128W

FOURTH INSERTION

NOTICE OF APPLICATION FOR TAX DEED

NOTICE IS HEREBY GIVEN that FIG FL18 LLC the holder of the following certificate has filed said certificate for a TAX DEED to be issued thereon. The Certificate number and year of issuance, the description of the property, and the names in which it was assessed are as follows:

CERTIFICATE NUMBER: 2018-10264

YEAR OF ISSUANCE: 2018

DESCRIPTION OF PROPERTY: ROSE SUB 12/26 LOT 3

PARCEL ID # 33-22-29-7711-00-030

Name in which assessed:
GREATER NEW HOPE MISSIONARY BAPTIST

ALL of said property being in the County of Orange, State of Florida. Unless such certificate shall be redeemed according to law, the property described in such certificate will be sold to the highest bidder online at www.orange.realtaxdeed.com scheduled to begin at 10:00 a.m. ET, Oct 15, 2020.

Dated: Aug 27, 2020
Phil Diamond
County Comptroller
Orange County, Florida
By: M Hildebrandt
Deputy Comptroller
September 3, 10, 17, 24, 2020
20-03134W

FOURTH INSERTION

NOTICE OF APPLICATION FOR TAX DEED

NOTICE IS HEREBY GIVEN that FIG FL18 LLC the holder of the following certificate has filed said certificate for a TAX DEED to be issued thereon. The Certificate number and year of issuance, the description of the property, and the names in which it was assessed are as follows:

CERTIFICATE NUMBER: 2018-11388

YEAR OF ISSUANCE: 2018

DESCRIPTION OF PROPERTY: RICHMOND HEIGHTS NO 7 3/4 LOT 234

PARCEL ID # 05-23-29-7408-02-340

Name in which assessed:
MARKESHA DUNLAP

ALL of said property being in the County of Orange, State of Florida. Unless such certificate shall be redeemed according to law, the property described in such certificate will be sold to the highest bidder online at www.orange.realtaxdeed.com scheduled to begin at 10:00 a.m. ET, Oct 15, 2020.

Dated: Aug 27, 2020
Phil Diamond
County Comptroller
Orange County, Florida
By: M Hildebrandt
Deputy Comptroller
September 3, 10, 17, 24, 2020
20-03140W

FOURTH INSERTION

NOTICE OF APPLICATION FOR TAX DEED

NOTICE IS HEREBY GIVEN that FIG FL18 LLC the holder of the following certificate has filed said certificate for a TAX DEED to be issued thereon. The Certificate number and year of issuance, the description of the property, and the names in which it was assessed are as follows:

CERTIFICATE NUMBER: 2018-9818

YEAR OF ISSUANCE: 2018

DESCRIPTION OF PROPERTY: ORLO VISTA TERRACE ANNEX N/96 LOTS 6 THROUGH 9 BLK J (LESS W 56 FT FOR R/W) & (LESS PT TAKEN ON W FOR R/W PER 6297/3826)

PARCEL ID # 30-22-29-6426-10-060

Name in which assessed:
JOSEFS HOSPITALITY LLC

ALL of said property being in the County of Orange, State of Florida. Unless such certificate shall be redeemed according to law, the property described in such certificate will be sold to the highest bidder online at www.orange.realtaxdeed.com scheduled to begin at 10:00 a.m. ET, Oct 15, 2020.

Dated: Aug 27, 2020
Phil Diamond
County Comptroller
Orange County, Florida
By: M Hildebrandt
Deputy Comptroller
September 3, 10, 17, 24, 2020
20-03129W

FOURTH INSERTION

NOTICE OF APPLICATION FOR TAX DEED

NOTICE IS HEREBY GIVEN that FIG FL18 LLC the holder of the following certificate has filed said certificate for a TAX DEED to be issued thereon. The Certificate number and year of issuance, the description of the property, and the names in which it was assessed are as follows:

CERTIFICATE NUMBER: 2018-10762

YEAR OF ISSUANCE: 2018

DESCRIPTION OF PROPERTY: WESTWOOD GARDENS SUB R/91 LOT 31 (LESS PART IN R/W) & (LESS PT ON S TAKEN FOR R/W PER 9364/1227)

PARCEL ID # 02-23-29-9232-00-310

Name in which assessed:
MARIA BIERD

ALL of said property being in the County of Orange, State of Florida. Unless such certificate shall be redeemed according to law, the property described in such certificate will be sold to the highest bidder online at www.orange.realtaxdeed.com scheduled to begin at 10:00 a.m. ET, Oct 15, 2020.

Dated: Aug 27, 2020
Phil Diamond
County Comptroller
Orange County, Florida
By: M Hildebrandt
Deputy Comptroller
September 3, 10, 17, 24, 2020
20-03135W

FOURTH INSERTION

NOTICE OF APPLICATION FOR TAX DEED

NOTICE IS HEREBY GIVEN that LUKE R POWELL (A MINOR) FUMAROBERT E POWELL CUST FOR the holder of the following certificate has filed said certificate for a TAX DEED to be issued thereon. The Certificate number and year of issuance, the description of the property, and the names in which it was assessed are as follows:

CERTIFICATE NUMBER: 2018-11455

YEAR OF ISSUANCE: 2018

DESCRIPTION OF PROPERTY: GRAND RESERVE AT KIRKMAN PARKE CONDOMINIUM 8697/2263 UNIT 1515 BLDG 15

PARCEL ID # 07-23-29-3139-15-150

Name in which assessed:
LYNDA D WARD, EMILY P GOLDEY

ALL of said property being in the County of Orange, State of Florida. Unless such certificate shall be redeemed according to law, the property described in such certificate will be sold to the highest bidder online at www.orange.realtaxdeed.com scheduled to begin at 10:00 a.m. ET, Oct 15, 2020.

Dated: Aug 27, 2020
Phil Diamond
County Comptroller
Orange County, Florida
By: M Hildebrandt
Deputy Comptroller
September 3, 10, 17, 24, 2020
20-03141W

FOURTH INSERTION

NOTICE OF APPLICATION FOR TAX DEED

NOTICE IS HEREBY GIVEN that FIG FL18 LLC the holder of the following certificate has filed said certificate for a TAX DEED to be issued thereon. The Certificate number and year of issuance, the description of the property, and the names in which it was assessed are as follows:

CERTIFICATE NUMBER: 2018-9832

YEAR OF ISSUANCE: 2018

DESCRIPTION OF PROPERTY: WESTSIDE CROSSING CONDOMINIUM 8259/4042 UNIT D2 BLDG B

PARCEL ID # 30-22-29-9195-04-002

Name in which assessed:
PANGS PARTNERSHIP LC

ALL of said property being in the County of Orange, State of Florida. Unless such certificate shall be redeemed according to law, the property described in such certificate will be sold to the highest bidder online at www.orange.realtaxdeed.com scheduled to begin at 10:00 a.m. ET, Oct 15, 2020.

Dated: Aug 27, 2020
Phil Diamond
County Comptroller
Orange County, Florida
By: M Hildebrandt
Deputy Comptroller
September 3, 10, 17, 24, 2020
20-03130W

FOURTH INSERTION

NOTICE OF APPLICATION FOR TAX DEED

NOTICE IS HEREBY GIVEN that FIG FL18 LLC the holder of the following certificate has filed said certificate for a TAX DEED to be issued thereon. The Certificate number and year of issuance, the description of the property, and the names in which it was assessed are as follows:

CERTIFICATE NUMBER: 2018-10777

YEAR OF ISSUANCE: 2018

DESCRIPTION OF PROPERTY: ANGEBILT ADDITION H/79 LOT 10 BLK 7

PARCEL ID # 03-23-29-0180-07-100

Name in which assessed:
GHISLAINE BERTILJEN

ALL of said property being in the County of Orange, State of Florida. Unless such certificate shall be redeemed according to law, the property described in such certificate will be sold to the highest bidder online at www.orange.realtaxdeed.com scheduled to begin at 10:00 a.m. ET, Oct 15, 2020.

Dated: Aug 27, 2020
Phil Diamond
County Comptroller
Orange County, Florida
By: M Hildebrandt
Deputy Comptroller
September 3, 10, 17, 24, 2020
20-03136W

FOURTH INSERTION

NOTICE OF APPLICATION FOR TAX DEED

NOTICE IS HEREBY GIVEN that FIG FL18 LLC the holder of the following certificate has filed said certificate for a TAX DEED to be issued thereon. The Certificate number and year of issuance, the description of the property, and the names in which it was assessed are as follows:

CERTIFICATE NUMBER: 2018-11642

YEAR OF ISSUANCE: 2018

DESCRIPTION OF PROPERTY: LEMON TREE SECTION 1 CONDO CB 3/141 BLDG 8 UNIT F

PARCEL ID # 09-23-29-5050-08-060

Name in which assessed:
CARLOS A FLORES

ALL of said property being in the County of Orange, State of Florida. Unless such certificate shall be redeemed according to law, the property described in such certificate will be sold to the highest bidder online at www.orange.realtaxdeed.com scheduled to begin at 10:00 a.m. ET, Oct 15, 2020.

Dated: Aug 27, 2020
Phil Diamond
County Comptroller
Orange County, Florida
By: M Hildebrandt
Deputy Comptroller
September 3, 10, 17, 24, 2020
2

ORANGE COUNTY

SUBSEQUENT INSERTIONS

THIRD INSERTION

NOTICE OF ACTION FOR DISSOLUTION OF MARRIAGE (NO CHILD OR FINANCIAL SUPPORT) IN THE CIRCUIT COURT OF THE NINTH JUDICIAL CIRCUIT IN AND FOR ORANGE COUNTY, FLORIDA

CASE NO.: 2019-DR-15447
EKATERINA TSIULYA
Petitioner/Wife
vs.
STEWART MCFADDEN,
Respondent/Husband.
TO: STEWART MCFADDEN 11904
Atlin Drive Orlando, FL 32837
YOU ARE NOTIFIED that an action for dissolution of marriage has been filed against you and that you are required to serve a copy of your written defenses, if any, to it on EKATERINA TSIULYA whose address is 657 Maitland Avenue Altamonte Springs, FL 32701 and file the original with the clerk of this Court at 425 N. Orange Ave., Orlando FL 32801, on or before October 22, 2020 before service on Petitioner or immediately thereafter. If you fail to do so, a default may be entered against you for the relief demanded in the petition.

Copies of all court documents in this case, including orders, are available at the Clerk of the Circuit Court's office. You may review these documents upon request.

You must keep the Clerk of the Circuit Court's office notified of your current address/email address. (You may file Notice, Florida Family Law Form 12.915.) Future papers in this lawsuit will be mailed to the address on record at the clerk's office.

WARNING: Rule 12.285, Florida Family Law Rules of Procedure, requires certain automatic disclosure of documents and information. Failure to comply can result in sanctions, including dismissal or striking of pleadings.

DATED: 7/11/19
TIFFANY MOORE RUSSELL
CLERK OF THE CIRCUIT COURT
By: Felicia Sanders, Deputy Clerk
2020.08.26 09:27:52 -04'00'
425 North Orange Ave.
Suite 320
Orlando, Florida 32801

McClellan Law Group
W.A. Randolph McClellan, Esq.
Florida Bar # 98582
Randy@McClellanLawGroup.com
Melissa G. Morales, Esq.
Florida Bar # 1022142
Melissa@McClellanLawGroup.com
657 Maitland Avenue
Altamonte Springs, FL 32701
Tel. (407) 753.4455
Fax. (407) 753.4480
Primary E-mail:
Pleadings@McClellanLawGroup.com
Sep. 10, 17, 24; Oct. 1, 2020
20-03503W

FOURTH INSERTION

NOTICE OF APPLICATION FOR TAX DEED

NOTICE IS HEREBY GIVEN that FIG FL18 LLC the holder of the following certificate has filed said certificate for a TAX DEED to be issued thereon. The Certificate number and year of issuance, the description of the property, and the names in which it was assessed are as follows:

CERTIFICATE NUMBER: 2018-5431
YEAR OF ISSUANCE: 2018

DESCRIPTION OF PROPERTY:
SUNSET LAKE CONDOMINIUM
8472/3367 UNIT 1310 BLDG 13

PARCEL ID # 12-23-28-8187-01-310

Name in which assessed:
PAULA BAXLEY, GARY BAXLEY

ALL of said property being in the County of Orange, State of Florida. Unless such certificate shall be redeemed according to law, the property described in such certificate will be sold to the highest bidder online at www.orange.realtaxdeed.com scheduled to begin at 10:00 a.m. ET, Oct 15, 2020.

Dated: Aug 27, 2020
Phil Diamond
County Comptroller
Orange County, Florida
By: M Hildebrandt
Deputy Comptroller
September 3, 10, 17, 24, 2020
20-03119W



SAVE TIME

E-mail your Legal Notice
legal@businessobserverfl.com

IV10236

THIRD INSERTION

NOTICE OF ACTION IN THE CIRCUIT COURT, OF THE 9TH JUDICIAL CIRCUIT IN, AND FOR ORANGE COUNTY, FLORIDA

CASE NO.: 2017-CA-008224-O
DEUTSCHE BANK NATIONAL TRUST COMPANY, as Trustee for Argent Securities, Inc., Asset-Backed Pass-Through Certificates, Series 2005-W5, Plaintiff, v. CARMEN BRAVO, et al. Defendants. IDA BENITEZ, Cross-Plaintiff, v. CARMEN BRAVO, Cross-Defendant.
TO: Carmen Bravo
Last Known Address:
8325 Sarnow Dr., Orlando, FL 32822
YOU ARE NOTIFIED that a Cross-claim action for Quiet Title and Cancellation of Deed has been filed against you

FOURTH INSERTION

NOTICE OF ACTION FOR PUBLICATION IN THE CIRCUIT COURT OF THE NINTH JUDICIAL CIRCUIT, IN AND FOR ORANGE COUNTY, FLORIDA

CASE NO.: 2020-DR-005775
ROBERT SCOTT
Petitioner,
vs.
ASHLEY MARIE SCOTT
Respondent.
TO: ASHLEY MARIE SCOTT
YOU ARE NOTIFIED that an action for Petition for Dissolution of Marriage with Minor Children and Related Relief, has been filed against you. You are required to serve a copy of your written defenses, if any, to this action on Eneid Bano, Esq. Petitioner's attorney, whose address is 390 N Orange Ave Ste 2300, Orlando, FL 32801, on or before October 22, 2020, and file the original with the clerk of this court at Orange County Courthouse, 425 N. Orange Ave, Orlando, Florida 32801, either before service on Petitioner's attorney or immediately thereafter; otherwise a default will be entered against you for the relief demanded in the petition.

WARNING: Rule 12.285, Florida Family Law Rules of Procedure, requires certain automatic disclosure of documents and information. Failure to comply can result in sanctions, including dismissal or striking of pleadings.

DATED: 8/26/2020
TIFFANY MOORE RUSSELL
CLERK OF THE CIRCUIT COURT
By: Felicia Sanders, Deputy Clerk
2020.08.26 10:24:10 -0400'
425 North Orange Ave.
Suite 320
Orlando, Florida 32801
September 3, 10, 17, 24, 2019
20-03280W

FOURTH INSERTION

NOTICE OF APPLICATION FOR TAX DEED

NOTICE IS HEREBY GIVEN that FLORIDA TAX CERTIFICATE FUND 1 MUNICIPAL TAX LLC the holder of the following certificate has filed said certificate for a TAX DEED to be issued thereon. The Certificate number and year of issuance, the description of the property, and the names in which it was assessed are as follows:

CERTIFICATE NUMBER: 2018-5837
YEAR OF ISSUANCE: 2018

DESCRIPTION OF PROPERTY:
TOSCANA UNIT 1 55/77 LOT 136

PARCEL ID # 26-23-28-8203-01-360

Name in which assessed: REAL ESTATE BK FUND ASSETS LLC

ALL of said property being in the County of Orange, State of Florida. Unless such certificate shall be redeemed according to law, the property described in such certificate will be sold to the highest bidder online at www.orange.realtaxdeed.com scheduled to begin at 10:00 a.m. ET, Oct 15, 2020.

Dated: Aug 27, 2020
Phil Diamond
County Comptroller
Orange County, Florida
By: M Hildebrandt
Deputy Comptroller
September 3, 10, 17, 24, 2020
20-03120W

FOURTH INSERTION

GASTROENTEROLOGY CONSULTANTS CFL OFFICE RELOCATION
Nasim Ahmed, MD announces the relocation of his practice from 7328 Stonerock Cir, Orlando 32819 to his new office 7364 Stonerock Cir, Ste B., Orlando, 32819.
Patients may call 407-345-7990.
September 10, 17, 24; October 1, 2020
20-03472W

in the instant case. You are required to serve a copy of your written defenses, if any, on Cross Plaintiff's attorney, whose name and address are, Lisa R. Patten, Esquire, Patten & Associates, 7575 Dr. Phillips Blvd., Suite 250, Orlando, FL 32819, on or before October 29, 2020, and to file the original of the written defenses with the clerk of this court either before service on Cross Plaintiff's Attorney or immediately thereafter. Failure to serve and file written defenses as required may result in a default or order for the relief demanded, without further notice.

TIFFANY MOORE RUSSELL,
CLERK OF THE CIRCUIT COURT
By Sandra Jackson, Deputy Clerk
2020-09-08 08:34:32
Deputy Clerk
425 North Orange Ave.
Suite 350
Orlando, Florida 32801
Sep. 10, 17, 24; Oct. 1, 2020
20-03501W

FOURTH INSERTION

NOTICE OF APPLICATION FOR TAX DEED

NOTICE IS HEREBY GIVEN that FIG FL18 LLC the holder of the following certificate has filed said certificate for a TAX DEED to be issued thereon. The Certificate number and year of issuance, the description of the property, and the names in which it was assessed are as follows:

CERTIFICATE NUMBER: 2018-1931

YEAR OF ISSUANCE: 2018

DESCRIPTION OF PROPERTY: E1/2 OF SE1/4 OF SW1/4 (LESS N 770 FT OF S 800 FT OF E 300 FT OF W 350 FT THEREOF & LESS S 30 FT FOR RD R/W) OF SEC 03-21-28

PARCEL ID # 03-21-28-0000-00-038

Name in which assessed: JUDITH GABBAI TR, AMIR DAVID GABBAI TR, OREN RANDY GABBAI TR, SAMUEL JACOBSON TR

ALL of said property being in the County of Orange, State of Florida. Unless such certificate shall be redeemed according to law, the property described in such certificate will be sold to the highest bidder online at www.orange.realtaxdeed.com scheduled to begin at 10:00 a.m. ET, Oct 15, 2020.

Dated: Aug 27, 2020
Phil Diamond
County Comptroller
Orange County, Florida
By: M Hildebrandt
Deputy Comptroller
September 3, 10, 17, 24, 2020
20-03115W

FOURTH INSERTION

NOTICE OF APPLICATION FOR TAX DEED

NOTICE IS HEREBY GIVEN that FLORIDA TAX CERTIFICATE FUND 1 MUNICIPAL TAX LLC the holder of the following certificate has filed said certificate for a TAX DEED to be issued thereon. The Certificate number and year of issuance, the description of the property, and the names in which it was assessed are as follows:

CERTIFICATE NUMBER: 2018-8743

YEAR OF ISSUANCE: 2018

DESCRIPTION OF PROPERTY: PINE HILLS SUB NO 6 T/8 LOT 4 BLK D

PARCEL ID # 19-22-29-6950-04-040

Name in which assessed: BILLY ROBERTSON 1/3 INT, JAMES ROBERTSON 1/3 INT, RICHARD ROBERTSON 1/3 INT

ALL of said property being in the County of Orange, State of Florida. Unless such certificate shall be redeemed according to law, the property described in such certificate will be sold to the highest bidder online at www.orange.realtaxdeed.com scheduled to begin at 10:00 a.m. ET, Oct 15, 2020.

Dated: Aug 27, 2020
Phil Diamond
County Comptroller
Orange County, Florida
By: M Hildebrandt
Deputy Comptroller
September 3, 10, 17, 24, 2020
20-03121W

SECOND INSERTION

NOTICE OF PUBLIC SALE Central Florida RV Center gives notice and intent to sell, for nonpayment of storage fees the following vehicle on 10/5/20 at 8:30 AM at 2488 S. Orange Blossom Trail Apopka, FL 32703. Said Company reserves the right to accept or reject any and all bids.
03 FORV by Otto Gregor Fischer
VIN# 1FCNF53S320A08742
September 17, 24, 2020 20-03616W

FOURTH INSERTION

NOTICE OF APPLICATION FOR TAX DEED
NOTICE IS HEREBY GIVEN that FIG FL18 LLC the holder of the following certificate has filed said certificate for a TAX DEED to be issued thereon. The Certificate number and year of issuance, the description of the property, and the names in which it was assessed are as follows:

CERTIFICATE NUMBER: 2018-1994

YEAR OF ISSUANCE: 2018

DESCRIPTION OF PROPERTY:
MARTIN PLACE REPLAT 14/115 LOT 25

PARCEL ID # 04-21-28-5525-00-250

Name in which assessed:
ROGELIO ESPINO, EVA ESPINO

ALL of said property being in the County of Orange, State of Florida. Unless such certificate shall be redeemed according to law, the property described in such certificate will be sold to the highest bidder online at www.orange.realtaxdeed.com scheduled to begin at 10:00 a.m. ET, Oct 15, 2020.

Dated: Aug 27, 2020
Phil Diamond
County Comptroller
Orange County, Florida
By: M Hildebrandt
Deputy Comptroller
September 3, 10, 17, 24, 2020
20-03116W

FOURTH INSERTION

NOTICE OF APPLICATION FOR TAX DEED

NOTICE IS HEREBY GIVEN that FIG FL18 LLC the holder of the following certificate has filed said certificate for a TAX DEED to be issued thereon. The Certificate number and year of issuance, the description of the property, and the names in which it was assessed are as follows:

CERTIFICATE NUMBER: 2018-8800

YEAR OF ISSUANCE: 2018

DESCRIPTION OF PROPERTY: PINE HILLS SUB NO 12 U/4 LOT 10 BLK A

PARCEL ID # 19-22-29-6962-01-100

Name in which assessed:
DELVA WILNER

ALL of said property being in the County of Orange, State of Florida. Unless such certificate shall be redeemed according to law, the property described in such certificate will be sold to the highest bidder online at www.orange.realtaxdeed.com scheduled to begin at 10:00 a.m. ET, Oct 15, 2020.

Dated: Aug 27, 2020
Phil Diamond
County Comptroller
Orange County, Florida
By: M Hildebrandt
Deputy Comptroller
September 3, 10, 17, 24, 2020
20-03122W

THIRD INSERTION

NOTICE OF APPLICATION FOR TAX DEED

NOTICE IS HEREBY GIVEN that FIG FL18 LLC the holder of the following certificate has filed said certificate for a TAX DEED to be issued thereon. The Certificate number and year of issuance, the description of the property, and the names in which it was assessed are as follows:

CERTIFICATE NUMBER: 2018-14238

YEAR OF ISSUANCE: 2018

DESCRIPTION OF PROPERTY:
CAPRI AT HUNTERS CREEK
CONDOMINIUM 8721/3950
UNIT 1504

PARCEL ID # 34-24-29-1127-01-504

Name in which assessed: SEBASTIAN A BOGNI, MAXIMILIANA S BOGNI, NORMA L VALVERDE DE BOGNI, AUGUSTO H BOGNI-FOJO

ALL of said property being in the County of Orange, State of Florida. Unless such certificate shall be redeemed according to law, the property described in such certificate will be sold to the highest bidder online at www.orange.realtaxdeed.com scheduled to begin at 10:00 a.m. ET, Oct 22, 2020.

Dated: Sep 03, 2020
Phil Diamond
County Comptroller
Orange County, Florida
By: M Hildebrandt
Deputy Comptroller
Sep. 10, 17, 24; Oct. 1, 2020
20-03335W

FOURTH INSERTION

NOTICE OF APPLICATION FOR TAX DEED
NOTICE IS HEREBY GIVEN that FIG FL18 LLC the holder of the following certificate has filed said certificate for a TAX DEED to be issued thereon. The Certificate number and year of issuance, the description of the property, and the names in which it was assessed are as follows:

CERTIFICATE NUMBER: 2018-3157

YEAR OF ISSUANCE: 2018

DESCRIPTION OF PROPERTY:
YOGI BEARS JELLYSTONE
PK CAMP RESORT (APOPKA)
3347/2482 UNIT 2505

PARCEL ID # 27-21-28-9805-02-505

Name in which assessed:
WALLACE D LAMB ESTATE

ALL of said property being in the County of Orange, State of Florida. Unless such certificate shall be redeemed according to law, the property described in such certificate will be sold to the highest bidder online at www.orange.realtaxdeed.com scheduled to begin at 10:00 a.m. ET, Oct 15, 2020.

Dated: Aug 27, 2020
Phil Diamond
County Comptroller
Orange County, Florida
By: M Hildebrandt
Deputy Comptroller
September 3, 10, 17, 24, 2020
20-03117W

FOURTH INSERTION

NOTICE OF APPLICATION FOR TAX DEED

NOTICE IS HEREBY GIVEN that FIG FL18 LLC the holder of the following certificate has filed said certificate for a TAX DEED to be issued thereon. The Certificate number and year of issuance, the description of the property, and the names in which it was assessed are as follows:

CERTIFICATE NUMBER: 2018-8823

YEAR OF ISSUANCE: 2018

DESCRIPTION OF PROPERTY:
PINE HILLS MANOR NO 5 T/4 LOT 6 BLK C

PARCEL ID # 19-22-29-6982-03-060

Name in which assessed:
HENNY FRESSE

ALL of said property being in the County of Orange, State of Florida. Unless such certificate shall be redeemed according to law, the property described in such certificate will be sold to the highest bidder online at www.orange.realtaxdeed.com scheduled to begin at 10:00 a.m. ET, Oct 15, 2020.

Dated: Aug 27, 2020
Phil Diamond
County Comptroller
Orange County, Florida
By: M Hildebrandt
Deputy Comptroller
September 3, 10, 17, 24, 2020
20-03123W

THIRD INSERTION

NOTICE OF APPLICATION FOR TAX DEED

NOTICE IS HEREBY GIVEN that FIG FL18 LLC the holder of the following certificate has filed said certificate for a TAX DEED to be issued thereon. The Certificate number and year of issuance, the description of the property, and the names in which it was assessed are as follows:

CERTIFICATE NUMBER: 2018-14739

YEAR OF ISSUANCE: 2018

DESCRIPTION OF PROPERTY: E1/2 OF SW1/4 OF SE1/4 SEC 10-22-30 SEE 2954/1817

PARCEL ID # 10-22-30-0000-00-013

Name in which assessed:
WSG CORAL SPRINGS L P

ALL of said property being in the County of Orange, State of Florida. Unless such certificate shall be redeemed according to law, the property described in such certificate will be sold to the highest bidder online at www.orange.realtaxdeed.com scheduled to begin at 10:00 a.m. ET, Oct 22, 2020.

Dated: Sep 03, 2020
Phil Diamond
County Comptroller
Orange County, Florida
By: M Hildebrandt
Deputy Comptroller
Sep. 10, 17, 24; Oct. 1, 2020
20-03336W

FOURTH INSERTION

NOTICE OF APPLICATION FOR TAX DEED
NOTICE IS HEREBY GIVEN that FIG FL18 LLC the holder of the following certificate has filed said certificate for a TAX DEED to be issued thereon. The Certificate number and year of issuance, the description of the property, and the names in which it was assessed are as follows:

CERTIFICATE NUMBER: 2018-3958

YEAR OF ISSUANCE: 2018

DESCRIPTION OF PROPERTY:
BELROI V/69 THE W 50 FT OF LOT 5 BLK A

PARCEL ID # 14-22-28-0616-01-051

Name in which assessed:
MATTEW H WESTPHAL

ALL of said property being in the County of Orange, State of Florida. Unless such certificate shall be redeemed according to law, the property described in such certificate will be sold to the highest bidder online at www.orange.realtaxdeed.com scheduled to begin at 10:00 a.m. ET, Oct 15, 2020.

Dated: Aug 27, 2020
Phil Diamond
County Comptroller
Orange County, Florida
By: M Hildebrandt
Deputy Comptroller
September 3, 10, 17, 24, 2020
20-03118W

FOURTH INSERTION

NOTICE OF APPLICATION FOR TAX DEED

NOTICE IS HEREBY GIVEN that FIG FL18 LLC the holder of the following certificate has filed said certificate for a TAX DEED to be issued thereon. The Certificate number and year of issuance, the description of the property, and the names in which it was assessed are as follows:

CERTIFICATE NUMBER: 2018-9399

YEAR OF ISSUANCE: 2018

DESCRIPTION OF PROPERTY:
ADAM GLIKS REVISED C/42 THAT PT OF BLK B LYING E OF US 17/92-441 DESC AS: BEG AT SE COR BLK B TH RUN WEST 70.97 FT TH NELY 231.55 FT TH SOUTH 220.06 FT TO POB (LESS R/W PER 2958/1489)

PARCEL ID # 27-22-29-2984-02-001

Name in which assessed:
VIP INVESTMENT LLC

ALL of said property being in the County of Orange, State of Florida. Unless such certificate shall be redeemed according to law, the property described in such certificate will be sold to the highest bidder online at www.orange.realtaxdeed.com scheduled to begin at 10:00 a.m. ET, Oct 15, 2020.

Dated: Aug 27, 2020
Phil Diamond
County Comptroller
Orange County, Florida
By: M Hildebrandt
Deputy Comptroller
September 3, 10, 17, 24, 2020
20-03124W

SECOND INSERTION

NOTICE OF PUBLIC SALE
Sergios Auto Body Shop Inc. gives notice & intent to sell for nonpayment of labor, service & storage fees the following vehicle on 10/5/20 at 8:30 AM at 1220 W Church St., Orlando, FL 32805. Parties claiming interest have rights to a hearing prior to sale with Clerk of Court. Owner has rights to recover possession of vehicle w/out judicial proceedings as pursuant to FL Statute 559.917. Any proceeds recovered from sale over the amount of lien will be deposited w/ Clerk of the Court for disposition upon court order. Said Company reserves the right to accept or reject any & all bids.
2012 HOND
VIN# 5FNFF3H52CB010036
September 17, 24, 2020 20-03619W

HOW TO PUBLISH YOUR

LEGAL NOTICE

IN THE BUSINESS OBSERVER

CALL

941-906-9386

and select the appropriate County name from the menu option

OR E-MAIL:

legal@businessobserverfl.com

Business Observer

IV10242

ORANGE COUNTY
SUBSEQUENT INSERTIONS

SECOND INSERTION

NOTICE OF ACTION FOR DISSOLUTION OF MARRIAGE WITH NO PROPERTY IN THE CIRCUIT COURT OF THE NINTH JUDICIAL CIRCUIT, IN AND FOR ORANGE COUNTY, FLORIDA

Case No.: 2017-DR-4302-O
Division: 30
IN THE MARRIAGE OF:
JESSICA PEREIRA LOPES BROWN,
Petitioner,
and
JOSHUA LYNN BROWN,
Respondent.
TO: JOSHUA LYNN BROWN
5543 Conroy Road
Apartment 2
Orlando, FL 32811-3636
United States

YOU ARE NOTIFIED that an action for Dissolution of Marriage has been filed against you and that you are required to serve a copy of your written defenses, if any, to it on JESSICA PEREIRA LOPES BROWN C/O TYRONE WATSON LAW, P.A., whose address is P.O. BOX 160876 ALTAMONTE SPRINGS, FLORIDA, 32716 on or before October 8, 2020 and file the original with the clerk of this Court 425 N. Orange Avenue Orlando, Florida 3280, on or before October 29, 2020, before service on Petitioner or immediately thereafter. If you fail to do so, a default may be entered against you for the relief demanded in the petition.

Copies of all court documents in this case, including orders, are available at the Clerk of the Circuit Court's office. You may review these documents upon request.

You must keep the Clerk of the Circuit Court's office notified of your current address. (You may file Designation of Current Mailing and E-Mail Address, Florida Supreme Court Approved Family Law Form 12.915.) Future papers in this lawsuit will be mailed or e-mailed to the address(es) on record at the clerk's office.

WARNING: Rule 12.285, Florida Family Law Rules of Procedure, requires certain automatic disclosure of documents and information. Failure to comply can result in sanctions, including dismissal or striking of pleadings.

Date: September 17, 2020
TIFFANY MOORE RUSSELL
CLERK OF THE CIRCUIT COURT
By:
Sep. 17, 24; Oct. 1, 8, 2020

20-03615W

SECOND INSERTION

IN THE CIRCUIT COURT, IN AND FOR ORANGE COUNTY, FLORIDA.

CASE NO.: 20-CA-002799-O #39 HOLIDAY INN CLUB VACATIONS INCORPORATED F/K/A ORANGE LAKE COUNTRY CLUB, INC.

Plaintiff, vs.
SHAPIRA ET.AL.,
Defendant(s).

NOTICE OF ACTION
Count VI

To: KEITH I STEINBERG
And all parties claiming interest by, through, under or against Defendant(s) KEITH I STEINBERG and all parties having or claiming to have any right, title or interest in the property herein described:

YOU ARE NOTIFIED that an action to foreclose a mortgage/claim of lien on the following described property in Orange County, Florida:

WEEK/UNIT:
26/003644
of Orange Lake Country Club Villas III, a Condominium, together with an undivided interest in the common elements appurtenant thereto, according to the Declaration of Condominium thereof recorded in Official Records Book 5914, Page 1965, in the Public Records of Orange County, Florida, and all amendments thereto; the plat of which is recorded in Condominium Book 28, page 84-92 until 12:00 noon on the first Saturday 2071, at which date said estate shall terminate; TOGETHER with a remainder over in fee simple absolute as tenant in common with the other owners of all the unit

weeks in the above described Condominium in the percentage interest established in the Declaration of Condominium.

has been filed against you and you are required to serve a copy of your written defenses, if any, to it on Jerry E. Aron, Plaintiff's attorney, whose address is 2505 Metrocentre Blvd., Suite 301, West Palm Beach, Florida, 33407, within thirty (30) days after the first publication of this Notice, and file the original with the Clerk of this Court either before service on Plaintiff's attorney or immediately thereafter, otherwise a default will be entered against you for the relief demanded in the Complaint.

If you are a person with disability who needs any accommodation in order to participate in a court proceeding or event, you are entitled, at no cost to you, to the provision of certain assistance. Please contact: in Orange County, ADA Coordinator, Human Resources, Orange County Courthouse, 425 N. Orange Avenue, Suite 510, Orlando, Florida, (407) 836-2303, fax: 407-836-2204; at least 7 days before your scheduled court appearance, or immediately upon receiving notification if the time before the scheduled court appearance is less than 7 days. If you are hearing or voice impaired, call 711 to reach the Telecommunications Relay Service.

TIFFANY MOORE RUSSELL
CLERK OF THE CIRCUIT COURT
ORANGE COUNTY, FLORIDA
Sandra Jackson, Deputy Clerk
2020-07-17 09:19:17
425 North Orange Ave.
Suite 350
Orlando, Florida 32801
September 17, 24, 2020 20-03595W

SECOND INSERTION

IN THE CIRCUIT COURT, IN AND FOR ORANGE COUNTY, FLORIDA.

CASE NO.: 20-CA-002799-O #39 HOLIDAY INN CLUB VACATIONS INCORPORATED F/K/A ORANGE LAKE COUNTRY CLUB, INC.

Plaintiff, vs.
SHAPIRA ET.AL.,
Defendant(s).

NOTICE OF ACTION
Count XI

To: BASIT YOUNUS
And all parties claiming interest by, through, under or against Defendant(s) BASIT YOUNUS and all parties having or claiming to have any right, title or interest in the property herein described:

YOU ARE NOTIFIED that an action to foreclose a mortgage/claim of lien on the following described property in Orange County, Florida:

WEEK/UNIT:
41, 42/086123
of Orange Lake Country Club Villas III, a Condominium, together with an undivided interest in the common elements appurtenant thereto, according to the Declaration of Condominium thereof recorded in Official Records Book 5914, Page 1965, in the Public Records of Orange County, Florida, and all amendments thereto; the plat of which is recorded in Condominium Book 28, page 84-92 until 12:00 noon on the first Saturday 2071, at which date said estate shall terminate; TOGETHER with a remainder over in fee simple absolute as tenant in common with the other owners of all the unit weeks in the above described

Condominium in the percentage interest established in the Declaration of Condominium.

has been filed against you and you are required to serve a copy of your written defenses, if any, to it on Jerry E. Aron, Plaintiff's attorney, whose address is 2505 Metrocentre Blvd., Suite 301, West Palm Beach, Florida, 33407, within thirty (30) days after the first publication of this Notice, and file the original with the Clerk of this Court either before service on Plaintiff's attorney or immediately thereafter, otherwise a default will be entered against you for the relief demanded in the Complaint.

If you are a person with disability who needs any accommodation in order to participate in a court proceeding or event, you are entitled, at no cost to you, to the provision of certain assistance. Please contact: in Orange County, ADA Coordinator, Human Resources, Orange County Courthouse, 425 N. Orange Avenue, Suite 510, Orlando, Florida, (407) 836-2303, fax: 407-836-2204; at least 7 days before your scheduled court appearance, or immediately upon receiving notification if the time before the scheduled court appearance is less than 7 days. If you are hearing or voice impaired, call 711 to reach the Telecommunications Relay Service.

TIFFANY MOORE RUSSELL
CLERK OF THE CIRCUIT COURT
ORANGE COUNTY, FLORIDA
Sandra Jackson, Deputy Clerk
2020-07-17 09:16:54
425 North Orange Ave.
Suite 350
Orlando, Florida 32801
September 17, 24, 2020 20-03600W

SECOND INSERTION

NOTICE OF ACTION IN THE CIRCUIT COURT OF THE NINTH JUDICIAL CIRCUIT IN AND FOR ORANGE COUNTY, FLORIDA

CASE NO.: 2020-CA-002833-O DEUTSCHE BANK NATIONAL TRUST COMPANY, AS TRUSTEE FOR SECURITIZED ASSET BACKED RECEIVABLES LLC TRUST 2006-WM4, Plaintiff, vs.

UNKNOWN HEIRS, BENEFICIARIES, DEWISEES, SURVIVING SPOUSE, GRANTEEES, ASSIGNEE, LIENORS, CREDITORS, TRUSTEES, AND ALL OTHER PARTIES CLAIMING AN INTEREST BY THROUGH UNDER OR AGAINST THE ESTATE OF JEANETTE MITCHELL, DECEASED; et al., Defendant(s).

TO: UNKNOWN HEIRS, BENEFICIARIES, DEWISEES, SURVIVING SPOUSE, GRANTEEES, LIENORS, CREDITORS, TRUSTEES, AND ALL OTHER PARTIES CLAIMING AN INTEREST BY THROUGH UNDER OR AGAINST THE ESTATE OF JEANETTE MITCHELL, DECEASED

Last Known Residence: UNKNOWN

YOU ARE NOTIFIED that an action to foreclose a mortgage on the following property in ORANGE County, Florida: LOT 508, MALIBU GROVES NINTH ADDITION, ACCORDING TO MAP OR PLAT THEREOF AS RECORDED IN PLAT BOOK 3, PAGE 137, OF THE PUBLIC RECORDS OF ORANGE COUNTY, FLORIDA.

has been filed against you and you are required to serve a copy of your written defenses, if any, to it on ALDRIDGE | PITE, LLP, Plaintiff's attorney, at 1615 South Congress Avenue, Suite 200, Delray Beach, FL 33445, on or before 30 days from the first date of publication, and file the original with the clerk of this court either before service on Plaintiff's attorney or immediately thereafter; otherwise a default will be entered against you for the relief demanded in the complaint or petition.

Tiffany Moore Russell
As Clerk of the Court
By: Sandra Jackson, Deputy Clerk
2020-09-04 08:52:44
As Deputy Clerk
425 North Orange Ave.
Suite 350
Orlando, Florida 32801

1221-4177B
September 17, 24, 2020 20-03650W

SECOND INSERTION

IN THE CIRCUIT COURT, IN AND FOR ORANGE COUNTY, FLORIDA.

CASE NO.: 20-CA-002799-O #39 HOLIDAY INN CLUB VACATIONS INCORPORATED F/K/A ORANGE LAKE COUNTRY CLUB, INC.

Plaintiff, vs.
SHAPIRA ET.AL.,
Defendant(s).

NOTICE OF ACTION
Count VII

To: NATALIE LISA TEAGUE
And all parties claiming interest by, through, under or against Defendant(s) NATALIE LISA TEAGUE and all parties having or claiming to have any right, title or interest in the property herein described:

YOU ARE NOTIFIED that an action to foreclose a mortgage/claim of lien on the following described property in Orange County, Florida:

WEEK/UNIT:
43/086444
of Orange Lake Country Club Villas III, a Condominium, together with an undivided interest in the common elements appurtenant thereto, according to the Declaration of Condominium thereof recorded in Official Records Book 5914, Page 1965, in the Public Records of Orange County, Florida, and all amendments thereto; the plat of which is recorded in Condominium Book 28, page 84-92 until 12:00 noon on the first Saturday 2071, at which date said estate shall terminate; TOGETHER with a remainder over in fee simple absolute as tenant in common with the other owners of all the unit

weeks in the above described Condominium in the percentage interest established in the Declaration of Condominium.

has been filed against you and you are required to serve a copy of your written defenses, if any, to it on Jerry E. Aron, Plaintiff's attorney, whose address is 2505 Metrocentre Blvd., Suite 301, West Palm Beach, Florida, 33407, within thirty (30) days after the first publication of this Notice, and file the original with the Clerk of this Court either before service on Plaintiff's attorney or immediately thereafter, otherwise a default will be entered against you for the relief demanded in the Complaint.

If you are a person with disability who needs any accommodation in order to participate in a court proceeding or event, you are entitled, at no cost to you, to the provision of certain assistance. Please contact: in Orange County, ADA Coordinator, Human Resources, Orange County Courthouse, 425 N. Orange Avenue, Suite 510, Orlando, Florida, (407) 836-2303, fax: 407-836-2204; at least 7 days before your scheduled court appearance, or immediately upon receiving notification if the time before the scheduled court appearance is less than 7 days. If you are hearing or voice impaired, call 711 to reach the Telecommunications Relay Service.

TIFFANY MOORE RUSSELL
CLERK OF THE CIRCUIT COURT
ORANGE COUNTY, FLORIDA
Sandra Jackson, Deputy Clerk
2020-06-22 10:18:50
425 North Orange Ave.
Suite 350
Orlando, Florida 32801
September 17, 24, 2020 20-03596W

SECOND INSERTION

IN THE CIRCUIT COURT, IN AND FOR ORANGE COUNTY, FLORIDA.

CASE NO.: 20-CA-002799-O #39 HOLIDAY INN CLUB VACATIONS INCORPORATED F/K/A ORANGE LAKE COUNTRY CLUB, INC.

Plaintiff, vs.
SHAPIRA ET.AL.,
Defendant(s).

NOTICE OF ACTION
Count IX

To: PEARL WU and JEVONS WANG
And all parties claiming interest by, through, under or against Defendant(s) PEARL WU and JEVONS WANG and all parties having or claiming to have any right, title or interest in the property herein described:

YOU ARE NOTIFIED that an action to foreclose a mortgage/claim of lien on the following described property in Orange County, Florida:

WEEK/UNIT:
48/003655
of Orange Lake Country Club Villas III, a Condominium, together with an undivided interest in the common elements appurtenant thereto, according to the Declaration of Condominium thereof recorded in Official Records Book 5914, Page 1965, in the Public Records of Orange County, Florida, and all amendments thereto; the plat of which is recorded in Condominium Book 28, page 84-92 until 12:00 noon on the first Saturday 2071, at which date said estate shall terminate; TOGETHER with a remainder over in fee simple absolute as tenant in common with the other owners of all the unit

weeks in the above described Condominium in the percentage interest established in the Declaration of Condominium.

has been filed against you and you are required to serve a copy of your written defenses, if any, to it on Jerry E. Aron, Plaintiff's attorney, whose address is 2505 Metrocentre Blvd., Suite 301, West Palm Beach, Florida, 33407, within thirty (30) days after the first publication of this Notice, and file the original with the Clerk of this Court either before service on Plaintiff's attorney or immediately thereafter, otherwise a default will be entered against you for the relief demanded in the Complaint.

If you are a person with disability who needs any accommodation in order to participate in a court proceeding or event, you are entitled, at no cost to you, to the provision of certain assistance. Please contact: in Orange County, ADA Coordinator, Human Resources, Orange County Courthouse, 425 N. Orange Avenue, Suite 510, Orlando, Florida, (407) 836-2303, fax: 407-836-2204; at least 7 days before your scheduled court appearance, or immediately upon receiving notification if the time before the scheduled court appearance is less than 7 days. If you are hearing or voice impaired, call 711 to reach the Telecommunications Relay Service.

TIFFANY MOORE RUSSELL
CLERK OF THE CIRCUIT COURT
ORANGE COUNTY, FLORIDA
Sandra Jackson, Deputy Clerk
2020-07-15 12:17:17
425 North Orange Ave.
Suite 350
Orlando, Florida 32801
September 17, 24, 2020 20-03598W

SECOND INSERTION

NOTICE OF ACTION OF FORECLOSURE PROCEEDINGS - PROPERTY

IN THE COUNTY COURT FOR THE 9TH JUDICIAL CIRCUIT IN AND FOR ORANGE COUNTY, FLORIDA

CASE: 2019-CC-4015-O ASHLIN PARK HOMEOWNERS ASSOCIATION, INC., a not-for-profit Florida corporation, Plaintiff, vs.

SAUD MOHAMED SALIM MOHAMED ALDAHMANI; FATIMA MOUSA MOHAMED ALI BINHUWAIDEN; AND UNKNOWN TENANT(S), Defendant.

TO: SAUD MOHAMED SALIM MOHAMED ALDAHMANI and FATIMA MOUSA MOHAMED ALI BINHUWAIDEN

YOU ARE HEREBY NOTIFIED that an action has been commenced to foreclose a Claim of Lien on the following real property, lying and being situated in Orange County, Florida, more particularly described as follows:

Lot 74, of ASHLIN PARK PHASE 1, according to the Plat thereof as recorded in Plat Book 83, Page(s) 129, of the Public Records of Orange County, Florida, and any subsequent amendments to the aforesaid.

A/K/A 11438 Misty Oak Alley, Windermere, FL 34786

This action has been filed against you and you are required to serve a copy of your written defense, if any, upon MANKIN LAW GROUP, Attorneys for Plaintiff, whose address is 2535 Landmark Drive, Suite 212, Clearwater, FL 33761, within thirty (30) days after the first publication of this notice and file the original with the clerk of this Court either before service on Plaintiff's attorney or immediately thereafter; otherwise a default will be entered against you for the relief demanded in the Complaint.

WITNESS my hand and seal of this Court on the 10 day of September, 2020.

TIFFANY MOORE RUSSELL
Circuit and County Courts
ANGEL ROSKOWSKI
CIVIL COURT SEAL
Deputy Clerk
CIVIL DIVISION
425 North Orange Avenue, Room 310
Orlando, Florida 32801-1526
September 17, 24, 2020 20-03651W

Business Observer

HOW TO PUBLISH YOUR LEGAL NOTICE

IN THE BUSINESS OBSERVER

CALL 941-906-9386

and select the appropriate County name from the menu option

OR E-MAIL:
legal@businessobserverfl.com

Business Observer

OFFICIAL **COURTHOUSE** WEBSITES:

MANATEE COUNTY: manateeclerk.com | SARASOTA COUNTY: sarasotaclerk.com

CHARLOTTE COUNTY: charlotte.realforeclose.com | LEE COUNTY: leeclerk.org

COLLIER COUNTY: collierclerk.com | HILLSBOROUGH COUNTY: hillsclerk.com

PASCO COUNTY: pasco.realforeclose.com | PINELLAS COUNTY: pinellasclerk.org

POLK COUNTY: polkcountyclerk.net | ORANGE COUNTY: myorangeclerk.com

Check out your notices on:
www.floridapublicnotices.com

Business Observer

LV10186

ORANGE COUNTY

SUBSEQUENT INSERTIONS

THIRD INSERTION

NOTICE OF APPLICATION FOR TAX DEED

NOTICE IS HEREBY GIVEN that JPL INVESTMENTS CORP the holder of the following certificate has filed said certificate for a TAX DEED to be issued thereon. The Certificate number and year of issuance, the description of the property, and the names in which it was assessed are as follows:

CERTIFICATE NUMBER: 2018-395

YEAR OF ISSUANCE: 2018

DESCRIPTION OF PROPERTY: BEG NE COR OF S1/2 OF SE1/4 OF NE1/4 OF NW1/4 RUN S 130 FT W 225 FT N 130 FT E 225 FT TO POB (LESS E 30 FT RD R/W) IN SEC 01-21-27

PARCEL ID # 01-21-27-0000-00-011

Name in which assessed: SANDRA MONROE-COLLINS 1/4 INT, EURA B MONROE 1/4 INT, ARTHUR J MONROE 1/4 INT, MARVIN V L MONROE 1/4 INT

ALL of said property being in the County of Orange, State of Florida. Unless such certificate shall be redeemed according to law, the property described in such certificate will be sold to the highest bidder online at www.orange.realtaxdeed.com scheduled to begin at 10:00 a.m. ET, Oct 22, 2020.

Dated: Sep 03, 2020
Phil Diamond
County Comptroller
Orange County, Florida
By: M Hildebrandt
Deputy Comptroller
Sep. 10, 17, 24; Oct. 1, 2020

20-03317W

THIRD INSERTION

NOTICE OF APPLICATION FOR TAX DEED

NOTICE IS HEREBY GIVEN that FIG FL18 LLC the holder of the following certificate has filed said certificate for a TAX DEED to be issued thereon. The Certificate number and year of issuance, the description of the property, and the names in which it was assessed are as follows:

CERTIFICATE NUMBER: 2018-9648

YEAR OF ISSUANCE: 2018

DESCRIPTION OF PROPERTY: IVEY LANE ESTATES 2ND ADDITION 2/79 LOT 3 BLK C

PARCEL ID # 29-22-29-3931-03-030

Name in which assessed: CRYSTAL INVESTMENT PROPERTIES LLC

ALL of said property being in the County of Orange, State of Florida. Unless such certificate shall be redeemed according to law, the property described in such certificate will be sold to the highest bidder online at www.orange.realtaxdeed.com scheduled to begin at 10:00 a.m. ET, Oct 22, 2020.

Dated: Sep 03, 2020
Phil Diamond
County Comptroller
Orange County, Florida
By: M Hildebrandt
Deputy Comptroller
Sep. 10, 17, 24; Oct. 1, 2020

20-03323W

THIRD INSERTION

NOTICE OF APPLICATION FOR TAX DEED

NOTICE IS HEREBY GIVEN that FIG FL18 LLC the holder of the following certificate has filed said certificate for a TAX DEED to be issued thereon. The Certificate number and year of issuance, the description of the property, and the names in which it was assessed are as follows:

CERTIFICATE NUMBER: 2018-12031

YEAR OF ISSUANCE: 2018

DESCRIPTION OF PROPERTY: LAKE TYLER CONDO CB 5/16 BLDG C UNIT 11

PARCEL ID # 15-23-29-4778-03-110

Name in which assessed: LAKE TYLER CONDO ASSN INC

ALL of said property being in the County of Orange, State of Florida. Unless such certificate shall be redeemed according to law, the property described in such certificate will be sold to the highest bidder online at www.orange.realtaxdeed.com scheduled to begin at 10:00 a.m. ET, Oct 22, 2020.

Dated: Sep 03, 2020
Phil Diamond
County Comptroller
Orange County, Florida
By: M Hildebrandt
Deputy Comptroller
Sep. 10, 17, 24; Oct. 1, 2020

20-03329W

THIRD INSERTION

NOTICE OF APPLICATION FOR TAX DEED

NOTICE IS HEREBY GIVEN that IDE TECHNOLOGIES INC the holder of the following certificate has filed said certificate for a TAX DEED to be issued thereon. The Certificate number and year of issuance, the description of the property, and the names in which it was assessed are as follows:

CERTIFICATE NUMBER: 2018-2075

YEAR OF ISSUANCE: 2018

DESCRIPTION OF PROPERTY: MAP OF PLYMOUTH B/17 THE S HALF AS DES BEG 30 FT W & 20 FT N OF SE COR OF LOT 9 BLK N RUN W 202 FT N 101.40 FT E 202 FT S 101.40 FT TO POB & BEG 30 FT W 121.40 FT N OF SE COR OF LOT 9 BLK N TH RUN W 202 FT N 100.90 FT E 202 FT S 100.90 FT TO POB

PARCEL ID # 06-21-28-7172-14-096

Name in which assessed: SEAN WOLFORD, REBEKAH WOLFORD

ALL of said property being in the County of Orange, State of Florida. Unless such certificate shall be redeemed according to law, the property described in such certificate will be sold to the highest bidder online at www.orange.realtaxdeed.com scheduled to begin at 10:00 a.m. ET, Oct 22, 2020.

Dated: Sep 03, 2020
Phil Diamond
County Comptroller
Orange County, Florida
By: M Hildebrandt
Deputy Comptroller
Sep. 10, 17, 24; Oct. 1, 2020

20-03318W

THIRD INSERTION

NOTICE OF APPLICATION FOR TAX DEED

NOTICE IS HEREBY GIVEN that FIG FL18 LLC the holder of the following certificate has filed said certificate for a TAX DEED to be issued thereon. The Certificate number and year of issuance, the description of the property, and the names in which it was assessed are as follows:

CERTIFICATE NUMBER: 2018-9661

YEAR OF ISSUANCE: 2018

DESCRIPTION OF PROPERTY: FIRST ADDITION TO LAKE MANNS ADDITION TO ORLANDO K/29 N1/2 LOTS 11 TO 14 BLK P

PARCEL ID # 29-22-29-4593-16-111

Name in which assessed: GUSTAVO GERONIMO VERA, MONSERRAT ELIAS

ALL of said property being in the County of Orange, State of Florida. Unless such certificate shall be redeemed according to law, the property described in such certificate will be sold to the highest bidder online at www.orange.realtaxdeed.com scheduled to begin at 10:00 a.m. ET, Oct 22, 2020.

Dated: Sep 03, 2020
Phil Diamond
County Comptroller
Orange County, Florida
By: M Hildebrandt
Deputy Comptroller
Sep. 10, 17, 24; Oct. 1, 2020

20-03324W

THIRD INSERTION

NOTICE OF APPLICATION FOR TAX DEED

NOTICE IS HEREBY GIVEN that FIG FL18 LLC the holder of the following certificate has filed said certificate for a TAX DEED to be issued thereon. The Certificate number and year of issuance, the description of the property, and the names in which it was assessed are as follows:

CERTIFICATE NUMBER: 2018-12061

YEAR OF ISSUANCE: 2018

DESCRIPTION OF PROPERTY: MILLENNIUM PALMS CONDOMINIUM 9031/4073 UNIT 4747B

PARCEL ID # 15-23-29-5670-47-472

Name in which assessed: HAMID NASEEM

ALL of said property being in the County of Orange, State of Florida. Unless such certificate shall be redeemed according to law, the property described in such certificate will be sold to the highest bidder online at www.orange.realtaxdeed.com scheduled to begin at 10:00 a.m. ET, Oct 22, 2020.

Dated: Sep 03, 2020
Phil Diamond
County Comptroller
Orange County, Florida
By: M Hildebrandt
Deputy Comptroller
Sep. 10, 17, 24; Oct. 1, 2020

20-03330W

THIRD INSERTION

NOTICE OF APPLICATION FOR TAX DEED

NOTICE IS HEREBY GIVEN that FLORIDA TAX CERTIFICATE FUND 1 MUNICIPAL TAX LLC the holder of the following certificate has filed said certificate for a TAX DEED to be issued thereon. The Certificate number and year of issuance, the description of the property, and the names in which it was assessed are as follows:

CERTIFICATE NUMBER: 2018-3017

YEAR OF ISSUANCE: 2018

DESCRIPTION OF PROPERTY: PIEDMONT PARK 20/95 LOT 165

PARCEL ID # 24-21-28-6907-01-650

Name in which assessed: RODNEY STALLING, KAPRECE STALLING, GERALD STALLING

ALL of said property being in the County of Orange, State of Florida. Unless such certificate shall be redeemed according to law, the property described in such certificate will be sold to the highest bidder online at www.orange.realtaxdeed.com scheduled to begin at 10:00 a.m. ET, Oct 22, 2020.

Dated: Sep 03, 2020
Phil Diamond
County Comptroller
Orange County, Florida
By: M Hildebrandt
Deputy Comptroller
Sep. 10, 17, 24; Oct. 1, 2020

20-03319W

THIRD INSERTION

NOTICE OF APPLICATION FOR TAX DEED

NOTICE IS HEREBY GIVEN that FIG FL18 LLC the holder of the following certificate has filed said certificate for a TAX DEED to be issued thereon. The Certificate number and year of issuance, the description of the property, and the names in which it was assessed are as follows:

CERTIFICATE NUMBER: 2018-9810

YEAR OF ISSUANCE: 2018

DESCRIPTION OF PROPERTY: ORLO VISTA TERRACE ANNEX N/96 LOT 1 BLK D

PARCEL ID # 30-22-29-6426-04-010

Name in which assessed: PHYLLIS NEELEY

ALL of said property being in the County of Orange, State of Florida. Unless such certificate shall be redeemed according to law, the property described in such certificate will be sold to the highest bidder online at www.orange.realtaxdeed.com scheduled to begin at 10:00 a.m. ET, Oct 22, 2020.

Dated: Sep 03, 2020
Phil Diamond
County Comptroller
Orange County, Florida
By: M Hildebrandt
Deputy Comptroller
Sep. 10, 17, 24; Oct. 1, 2020

20-03325W

THIRD INSERTION

NOTICE OF APPLICATION FOR TAX DEED

NOTICE IS HEREBY GIVEN that LIEGE TAX LIENS LLC 18 the holder of the following certificate has filed said certificate for a TAX DEED to be issued thereon. The Certificate number and year of issuance, the description of the property, and the names in which it was assessed are as follows:

CERTIFICATE NUMBER: 2018-12688

YEAR OF ISSUANCE: 2018

DESCRIPTION OF PROPERTY: OAK TREE PLAZA CONDO 6128/2530 UNIT 7

PARCEL ID # 24-23-29-6079-00-070

Name in which assessed: GGH 50 LLC

ALL of said property being in the County of Orange, State of Florida. Unless such certificate shall be redeemed according to law, the property described in such certificate will be sold to the highest bidder online at www.orange.realtaxdeed.com scheduled to begin at 10:00 a.m. ET, Oct 22, 2020.

Dated: Sep 03, 2020
Phil Diamond
County Comptroller
Orange County, Florida
By: M Hildebrandt
Deputy Comptroller
Sep. 10, 17, 24; Oct. 1, 2020

20-03331W

THIRD INSERTION

NOTICE OF APPLICATION FOR TAX DEED

NOTICE IS HEREBY GIVEN that CYPRESS TAX LLC the holder of the following certificate has filed said certificate for a TAX DEED to be issued thereon. The Certificate number and year of issuance, the description of the property, and the names in which it was assessed are as follows:

CERTIFICATE NUMBER: 2018-3311

YEAR OF ISSUANCE: 2018

DESCRIPTION OF PROPERTY: CLEARVIEW HEIGHTS 1ST ADDITION Y/55 LOT 9

PARCEL ID # 35-21-28-1406-00-090

Name in which assessed: SERENDIPITY PROPERTY INVESTMENT LLC

ALL of said property being in the County of Orange, State of Florida. Unless such certificate shall be redeemed according to law, the property described in such certificate will be sold to the highest bidder online at www.orange.realtaxdeed.com scheduled to begin at 10:00 a.m. ET, Oct 22, 2020.

Dated: Sep 03, 2020
Phil Diamond
County Comptroller
Orange County, Florida
By: M Hildebrandt
Deputy Comptroller
Sep. 10, 17, 24; Oct. 1, 2020

20-03320W

THIRD INSERTION

NOTICE OF APPLICATION FOR TAX DEED

NOTICE IS HEREBY GIVEN that FIG FL18 LLC the holder of the following certificate has filed said certificate for a TAX DEED to be issued thereon. The Certificate number and year of issuance, the description of the property, and the names in which it was assessed are as follows:

CERTIFICATE NUMBER: 2018-11728

YEAR OF ISSUANCE: 2018

DESCRIPTION OF PROPERTY: WOODHAVEN J/127 LOTS 6 BLK O & THAT PORTION OF VAC R/W LYING N OF LOT 6 PER 5182/18

PARCEL ID # 09-23-29-9452-15-060

Name in which assessed: THEISEN BROTHERS INC, THEISEN BROTHERS GUNITE INC

ALL of said property being in the County of Orange, State of Florida. Unless such certificate shall be redeemed according to law, the property described in such certificate will be sold to the highest bidder online at www.orange.realtaxdeed.com scheduled to begin at 10:00 a.m. ET, Oct 22, 2020.

Dated: Sep 03, 2020
Phil Diamond
County Comptroller
Orange County, Florida
By: M Hildebrandt
Deputy Comptroller
Sep. 10, 17, 24; Oct. 1, 2020

20-03326W

THIRD INSERTION

NOTICE OF APPLICATION FOR TAX DEED

NOTICE IS HEREBY GIVEN that FIG FL18 LLC the holder of the following certificate has filed said certificate for a TAX DEED to be issued thereon. The Certificate number and year of issuance, the description of the property, and the names in which it was assessed are as follows:

CERTIFICATE NUMBER: 2018-12888

YEAR OF ISSUANCE: 2018

DESCRIPTION OF PROPERTY: SANDLAKE COURTYARDS CONDO 5901/3515 UNIT 1133 BLDG 6

PARCEL ID # 27-23-29-8012-01-133

Name in which assessed: WILFREDO RAMOS-PRADO

ALL of said property being in the County of Orange, State of Florida. Unless such certificate shall be redeemed according to law, the property described in such certificate will be sold to the highest bidder online at www.orange.realtaxdeed.com scheduled to begin at 10:00 a.m. ET, Oct 22, 2020.

Dated: Sep 03, 2020
Phil Diamond
County Comptroller
Orange County, Florida
By: M Hildebrandt
Deputy Comptroller
Sep. 10, 17, 24; Oct. 1, 2020

20-03332W

THIRD INSERTION

NOTICE OF APPLICATION FOR TAX DEED

NOTICE IS HEREBY GIVEN that LUKE R POWELL (A MINOR) FUTURE ROBERT E POWELL CUST FOR the holder of the following certificate has filed said certificate for a TAX DEED to be issued thereon. The Certificate number and year of issuance, the description of the property, and the names in which it was assessed are as follows:

CERTIFICATE NUMBER: 2018-7891

YEAR OF ISSUANCE: 2018

DESCRIPTION OF PROPERTY: LONDONDERRY HILLS SECTION 1 W/80 LOT 4 BLK D

PARCEL ID # 07-22-29-5172-04-040

Name in which assessed: TRAN THIEN PHONG, BUI THI DIEM PHUONG

ALL of said property being in the County of Orange, State of Florida. Unless such certificate shall be redeemed according to law, the property described in such certificate will be sold to the highest bidder online at www.orange.realtaxdeed.com scheduled to begin at 10:00 a.m. ET, Oct 22, 2020.

Dated: Sep 03, 2020
Phil Diamond
County Comptroller
Orange County, Florida
By: M Hildebrandt
Deputy Comptroller
Sep. 10, 17, 24; Oct. 1, 2020

20-03321W

THIRD INSERTION

NOTICE OF APPLICATION FOR TAX DEED

NOTICE IS HEREBY GIVEN that LIEGE TAX LIENS LLC 18 the holder of the following certificate has filed said certificate for a TAX DEED to be issued thereon. The Certificate number and year of issuance, the description of the property, and the names in which it was assessed are as follows:

CERTIFICATE NUMBER: 2018-11912

YEAR OF ISSUANCE: 2018

DESCRIPTION OF PROPERTY: CAMELOT BY THE LAKE CONDO CB 5/92 UNIT 17 BLDG M

PARCEL ID # 13-23-29-1139-13-170

Name in which assessed: JOSE RAUL VILLAVICENCIO

ALL of said property being in the County of Orange, State of Florida. Unless such certificate shall be redeemed according to law, the property described in such certificate will be sold to the highest bidder online at www.orange.realtaxdeed.com scheduled to begin at 10:00 a.m. ET, Oct 22, 2020.

Dated: Sep 03, 2020
Phil Diamond
County Comptroller
Orange County, Florida
By: M Hildebrandt
Deputy Comptroller
Sep. 10, 17, 24; Oct. 1, 2020

20-03327W

THIRD INSERTION

NOTICE OF APPLICATION FOR TAX DEED

NOTICE IS HEREBY GIVEN that FLORIDA TAX CERTIFICATE FUND 1 MUNICIPAL TAX LLC the holder of the following certificate has filed said certificate for a TAX DEED to be issued thereon. The Certificate number and year of issuance, the description of the property, and the names in which it was assessed are as follows:

CERTIFICATE NUMBER: 2018-13075

YEAR OF ISSUANCE: 2018

DESCRIPTION OF PROPERTY: ALLIANCE CONDOMINIUM 8149/3886 UNIT 258 BLK A2

PARCEL ID # 34-23-29-0108-01-258

Name in which assessed: IST CONTINENTAL GRANITE CORP

ALL of said property being in the County of Orange, State of Florida. Unless such certificate shall be redeemed according to law, the property described in such certificate will be sold to the highest bidder online at www.orange.realtaxdeed.com scheduled to begin at 10:00 a.m. ET, Oct 22, 2020.

Dated: Sep 03, 2020
Phil Diamond
County Comptroller
Orange County, Florida
By: M Hildebrandt
Deputy Comptroller
Sep. 10, 17, 24; Oct. 1, 2020

20-03333W

THIRD INSERTION

NOTICE OF APPLICATION FOR TAX DEED

NOTICE IS HEREBY GIVEN that MERCURY FUNDING LLC the holder of the following certificate has filed said certificate for a TAX DEED to be issued thereon. The Certificate number and year of issuance, the description of the property, and the names in which it was assessed are as follows:

CERTIFICATE NUMBER: 2018-9129

YEAR OF ISSUANCE: 2018

DESCRIPTION OF PROPERTY: MRS H PARKER HILL RESUB H/75 LOT 6

PARCEL ID # 25-22-29-3608-00-060

Name in which assessed: CATHERINE G FALK

ALL of said property being in the County of Orange, State of Florida. Unless such certificate shall be redeemed according to law, the property described in such certificate will be sold to the highest bidder online at www.orange.realtaxdeed.com scheduled to begin at 10:00 a.m. ET, Oct 22, 2020.

Dated: Sep 03, 2020
Phil Diamond
County Comptroller
Orange County, Florida
By: M Hildebrandt
Deputy Comptroller
Sep. 10, 17, 24; Oct. 1, 2020

20-03322W

THIRD INSERTION

NOTICE OF APPLICATION FOR TAX DEED

NOTICE IS HEREBY GIVEN that FIG FL18 LLC the holder of the following certificate has filed said certificate for a TAX DEED to be issued thereon. The Certificate number and year of issuance, the description of the property, and the names in which it was assessed are as follows:

CERTIFICATE NUMBER: 2018-12028

YEAR OF ISSUANCE: 2018

DESCRIPTION OF PROPERTY: LAKE TYLER CONDO CB 5/16 BLDG B UNIT 18

PARCEL ID # 15-23-29-4778-02-180

Name in which assessed: LAKE TYLER CONDO ASSN INC

ALL of said property being in the County of Orange, State of Florida. Unless such certificate shall be redeemed according to law, the property described in such certificate will be sold to the highest bidder online at www.orange.realtaxdeed.com scheduled to begin at 10:00 a.m. ET, Oct 22, 2020.

Dated: Sep 03, 2020
Phil Diamond
County Comptroller
Orange County, Florida
By: M Hildebrandt
Deputy Comptroller
Sep. 10, 17, 24; Oct. 1, 2020

20-03328W

THIRD INSERTION

NOTICE OF APPLICATION FOR TAX DEED

NOTICE IS HEREBY GIVEN that FIG FL18 LLC the holder of the following certificate has filed said certificate for a TAX DEED to be issued thereon. The Certificate number and year of issuance, the description of the property, and the names in which it was assessed are as follows:

CERTIFICATE NUMBER: 2018-13390

YEAR OF ISSUANCE: 2018

DESCRIPTION OF PROPERTY: TAFT E/4 LOT 6 BLK E TIER 4

PARCEL ID # 01-24-29-8516-41-106

Name in which assessed: KAREN HOLLIDAY

ALL of said property being in the County of Orange, State of Florida. Unless such certificate shall be redeemed according to law, the property described in such certificate will be sold to the highest bidder online at www.orange.realtaxdeed.com scheduled to begin at 10:00 a.m. ET, Oct 22, 2020.

Dated: Sep 03, 2020
Phil Diamond
County Comptroller
Orange County, Florida
By: M Hildebrandt
Deputy Comptroller
Sep. 10, 17, 24; Oct. 1, 2020

20-03334W

**ORANGE COUNTY
SUBSEQUENT INSERTIONS**

SECOND INSERTION

IN THE CIRCUIT COURT, IN AND FOR ORANGE COUNTY, FLORIDA.
CASE NO.: 20-CA-004030-0 #39 HOLIDAY INN CLUB VACATIONS INCORPORATED F/K/A ORANGE LAKE COUNTRY CLUB, INC. Plaintiff, vs. MCCURDY ET.AL., Defendant(s).

NOTICE OF ACTION
Count XIII
To: KATHLEEN M. WIENER and FREDERICK C WIENER AND ANY AND ALL UNKNOWN HEIRS, DEVISEES AND OTHER CLAIMANTS OF FREDERICK C. WEINER
And all parties claiming interest by, through, under or against Defendant(s) KATHLEEN M. WIENER and FREDERICK C. WEINER AND ANY AND ALL UNKNOWN HEIRS, DEVISEES AND OTHER CLAIMANTS OF FREDERICK C. WEINER and all parties having or claiming to have any right, title or interest in the property herein described:
YOU ARE NOTIFIED that an action to foreclose a mortgage/claim of lien on the following described property in Orange County, Florida:
WEEK/UNIT:
41-EVEN/087554
of Orange Lake Country Club Villas III, a Condominium, together with an undivided interest in the common elements appurtenant thereto, according to the Declaration of Condominium thereof recorded in Official Records Book 5914, Page 1965, in the Public Records of Orange County, Florida, and all amendments thereto; the plat of which is recorded in Condominium Book 28, page 84-92 until 12:00 noon on the first Saturday 2071, at which date said estate shall

terminate; TOGETHER with a remainder over in fee simple absolute as tenant in common with the other owners of all the unit weeks in the above described Condominium in the percentage interest established in the Declaration of Condominium.
has been filed against you and you are required to serve a copy of your written defenses, if any, to it on Jerry E. Aron, Plaintiff's attorney, whose address is 2505 Metrocentre Blvd., Suite 301, West Palm Beach, Florida, 33407, within thirty (30) days after the first publication of this Notice, and file the original with the Clerk of this Court either before service on Plaintiff's attorney or immediately thereafter, otherwise a default will be entered against you for the relief demanded in the Complaint.
If you are a person with disability who needs any accommodation in order to participate in a court proceeding or event, you are entitled, at no cost to you, to the provision of certain assistance. Please contact: in Orange County, ADA Coordinator, Human Resources, Orange County Courthouse, 425 N. Orange Avenue, Suite 510, Orlando, Florida, (407) 836-2303, fax: 407-836-2204; at least 7 days before your scheduled court appearance, or immediately upon receiving notification if the time before the scheduled court appearance is less than 7 days. If you are hearing or voice impaired, call 711 to reach the Telecommunications Relay Service.
TIFFANY MOORE RUSSELL
CLERK OF THE CIRCUIT COURT
ORANGE COUNTY, FLORIDA
Ramona Velez, Deputy Clerk
2020-05-19 08:20:54
425 North Orange Ave.
Suite 350
Orlando, Florida 32801
September 17, 24, 2020 20-03592W

SECOND INSERTION

IN THE CIRCUIT COURT, IN AND FOR ORANGE COUNTY, FLORIDA.
CASE NO.: 20-CA-004030-0 #39 HOLIDAY INN CLUB VACATIONS INCORPORATED F/K/A ORANGE LAKE COUNTRY CLUB, INC. Plaintiff, vs. MCCURDY ET.AL., Defendant(s).

NOTICE OF ACTION
Count XIV
To: FRANK G WILSON A/K/A FRANK G WILSON, SR. A/K/A FRANK GEORGE WILSON, SR. and CHARLOTTE B WILSON
And all parties claiming interest by, through, under or against Defendant(s) FRANK G WILSON A/K/A FRANK G WILSON, SR. A/K/A FRANK GEORGE WILSON, SR. and CHARLOTTE B WILSON and all parties having or claiming to have any right, title or interest in the property herein described:
YOU ARE NOTIFIED that an action to foreclose a mortgage/claim of lien on the following described property in Orange County, Florida:
WEEK/UNIT:
25/003644
of Orange Lake Country Club Villas III, a Condominium, together with an undivided interest in the common elements appurtenant thereto, according to the Declaration of Condominium thereof recorded in Official Records Book 5914, Page 1965, in the Public Records of Orange County, Florida, and all amendments thereto; the plat of which is recorded in Condominium Book 28, page 84-92 until 12:00 noon on the first Saturday 2071, at which date said estate shall terminate; TOGETHER with a

remainder over in fee simple absolute as tenant in common with the other owners of all the unit weeks in the above described Condominium in the percentage interest established in the Declaration of Condominium.
has been filed against you and you are required to serve a copy of your written defenses, if any, to it on Jerry E. Aron, Plaintiff's attorney, whose address is 2505 Metrocentre Blvd., Suite 301, West Palm Beach, Florida, 33407, within thirty (30) days after the first publication of this Notice, and file the original with the Clerk of this Court either before service on Plaintiff's attorney or immediately thereafter, otherwise a default will be entered against you for the relief demanded in the Complaint.
If you are a person with disability who needs any accommodation in order to participate in a court proceeding or event, you are entitled, at no cost to you, to the provision of certain assistance. Please contact: in Orange County, ADA Coordinator, Human Resources, Orange County Courthouse, 425 N. Orange Avenue, Suite 510, Orlando, Florida, (407) 836-2303, fax: 407-836-2204; at least 7 days before your scheduled court appearance, or immediately upon receiving notification if the time before the scheduled court appearance is less than 7 days. If you are hearing or voice impaired, call 711 to reach the Telecommunications Relay Service.
TIFFANY MOORE RUSSELL
CLERK OF THE CIRCUIT COURT
ORANGE COUNTY, FLORIDA
Sandra Jackson, Deputy Clerk
2020-07-01 13:07:37
425 North Orange Ave.
Suite 350
Orlando, Florida 32801
September 17, 24, 2020 20-03593W

SECOND INSERTION

IN THE CIRCUIT COURT, IN AND FOR ORANGE COUNTY, FLORIDA.
CASE NO.: 20-CA-002799-0 #39 HOLIDAY INN CLUB VACATIONS INCORPORATED F/K/A ORANGE LAKE COUNTRY CLUB, INC. Plaintiff, vs. SHAPIRA ET.AL., Defendant(s).

NOTICE OF ACTION
Count XII
To: DANIEL E ZANELLA and DANIEL E. ZANELLA, JR.
And all parties claiming interest by, through, under or against Defendant(s) DANIEL E ZANELLA and DANIEL E. ZANELLA, JR. and all parties having or claiming to have any right, title or interest in the property herein described:
YOU ARE NOTIFIED that an action to foreclose a mortgage/claim of lien on the following described property in Orange County, Florida:
WEEK/UNIT:
49/087946
of Orange Lake Country Club Villas III, a Condominium, together with an undivided interest in the common elements appurtenant thereto, according to the Declaration of Condominium thereof recorded in Official Records Book 5914, Page 1965, in the Public Records of Orange County, Florida, and all amendments thereto; the plat of which is recorded in Condominium Book 28, page 84-92 until 12:00 noon on the first Saturday 2071, at which date said estate shall terminate; TOGETHER with a remainder over in fee simple absolute as tenant in common with the other owners of all the unit

weeks in the above described Condominium in the percentage interest established in the Declaration of Condominium.
has been filed against you and you are required to serve a copy of your written defenses, if any, to it on Jerry E. Aron, Plaintiff's attorney, whose address is 2505 Metrocentre Blvd., Suite 301, West Palm Beach, Florida, 33407, within thirty (30) days after the first publication of this Notice, and file the original with the Clerk of this Court either before service on Plaintiff's attorney or immediately thereafter, otherwise a default will be entered against you for the relief demanded in the Complaint.
If you are a person with disability who needs any accommodation in order to participate in a court proceeding or event, you are entitled, at no cost to you, to the provision of certain assistance. Please contact: in Orange County, ADA Coordinator, Human Resources, Orange County Courthouse, 425 N. Orange Avenue, Suite 510, Orlando, Florida, (407) 836-2303, fax: 407-836-2204; at least 7 days before your scheduled court appearance, or immediately upon receiving notification if the time before the scheduled court appearance is less than 7 days. If you are hearing or voice impaired, call 711 to reach the Telecommunications Relay Service.
TIFFANY MOORE RUSSELL
CLERK OF THE CIRCUIT COURT
ORANGE COUNTY, FLORIDA
Sandra Jackson, Deputy Clerk
2020-07-17 09:12:38
425 North Orange Ave.
Suite 350
Orlando, Florida 32801
September 17, 24, 2020 20-03601W

SECOND INSERTION

IN THE CIRCUIT COURT, IN AND FOR ORANGE COUNTY, FLORIDA.
CASE NO.: 20-CA-004030-0 #39 HOLIDAY INN CLUB VACATIONS INCORPORATED F/K/A ORANGE LAKE COUNTRY CLUB, INC. Plaintiff, vs. MCCURDY ET.AL., Defendant(s).

NOTICE OF ACTION
Count VIII
To: PATRICIA A. SPAIN AND ANY AND ALL UNKNOWN HEIRS, DEVISEES AND OTHER CLAIMANTS OF PATRICIA A. SPAIN
And all parties claiming interest by, through, under or against Defendant(s) PATRICIA A. SPAIN AND ANY AND ALL UNKNOWN HEIRS, DEVISEES AND OTHER CLAIMANTS OF PATRICIA A. SPAIN and all parties having or claiming to have any right, title or interest in the property herein described:
YOU ARE NOTIFIED that an action to foreclose a mortgage/claim of lien on the following described property in Orange County, Florida:
WEEK/UNIT:
9/003594
of Orange Lake Country Club Villas III, a Condominium, together with an undivided interest in the common elements appurtenant thereto, according to the Declaration of Condominium thereof recorded in Official Records Book 5914, Page 1965, in the Public Records of Orange County, Florida, and all amendments thereto; the plat of which is recorded in Condominium Book 28, page 84-92 until 12:00 noon on the first Saturday 2071, at which date said estate shall terminate; TOGETHER with a

remainder over in fee simple absolute as tenant in common with the other owners of all the unit weeks in the above described Condominium in the percentage interest established in the Declaration of Condominium.
has been filed against you and you are required to serve a copy of your written defenses, if any, to it on Jerry E. Aron, Plaintiff's attorney, whose address is 2505 Metrocentre Blvd., Suite 301, West Palm Beach, Florida, 33407, within thirty (30) days after the first publication of this Notice, and file the original with the Clerk of this Court either before service on Plaintiff's attorney or immediately thereafter, otherwise a default will be entered against you for the relief demanded in the Complaint.
If you are a person with disability who needs any accommodation in order to participate in a court proceeding or event, you are entitled, at no cost to you, to the provision of certain assistance. Please contact: in Orange County, ADA Coordinator, Human Resources, Orange County Courthouse, 425 N. Orange Avenue, Suite 510, Orlando, Florida, (407) 836-2303, fax: 407-836-2204; at least 7 days before your scheduled court appearance, or immediately upon receiving notification if the time before the scheduled court appearance is less than 7 days. If you are hearing or voice impaired, call 711 to reach the Telecommunications Relay Service.
TIFFANY MOORE RUSSELL
CLERK OF THE CIRCUIT COURT
ORANGE COUNTY, FLORIDA
Sandra Jackson, Deputy Clerk
2020-05-14 12:22:29
425 North Orange Ave.
Suite 350
Orlando, Florida 32801
September 17, 24, 2020 20-03587W

SECOND INSERTION

IN THE CIRCUIT COURT, IN AND FOR ORANGE COUNTY, FLORIDA.
CASE NO.: 20-CA-004030-0 #39 HOLIDAY INN CLUB VACATIONS INCORPORATED F/K/A ORANGE LAKE COUNTRY CLUB, INC. Plaintiff, vs. MCCURDY ET.AL., Defendant(s).

NOTICE OF ACTION
Count IX
To: PATRICIA A. SPAIN AND ANY AND ALL UNKNOWN HEIRS, DEVISEES AND OTHER CLAIMANTS OF PATRICIA A. SPAIN
And all parties claiming interest by, through, under or against Defendant(s) PATRICIA A. SPAIN AND ANY AND ALL UNKNOWN HEIRS, DEVISEES AND OTHER CLAIMANTS OF PATRICIA A. SPAIN and all parties having or claiming to have any right, title or interest in the property herein described:
YOU ARE NOTIFIED that an action to foreclose a mortgage/claim of lien on the following described property in Orange County, Florida:
WEEK/UNIT:
47/087833
of Orange Lake Country Club Villas III, a Condominium, together with an undivided interest in the common elements appurtenant thereto, according to the Declaration of Condominium thereof recorded in Official Records Book 5914, Page 1965, in the Public Records of Orange County, Florida, and all amendments thereto; the plat of which is recorded in Condominium Book 28, page 84-92 until 12:00 noon on the first Saturday 2071, at which date said estate shall terminate; TOGETHER with a

remainder over in fee simple absolute as tenant in common with the other owners of all the unit weeks in the above described Condominium in the percentage interest established in the Declaration of Condominium.
has been filed against you and you are required to serve a copy of your written defenses, if any, to it on Jerry E. Aron, Plaintiff's attorney, whose address is 2505 Metrocentre Blvd., Suite 301, West Palm Beach, Florida, 33407, within thirty (30) days after the first publication of this Notice, and file the original with the Clerk of this Court either before service on Plaintiff's attorney or immediately thereafter, otherwise a default will be entered against you for the relief demanded in the Complaint.
If you are a person with disability who needs any accommodation in order to participate in a court proceeding or event, you are entitled, at no cost to you, to the provision of certain assistance. Please contact: in Orange County, ADA Coordinator, Human Resources, Orange County Courthouse, 425 N. Orange Avenue, Suite 510, Orlando, Florida, (407) 836-2303, fax: 407-836-2204; at least 7 days before your scheduled court appearance, or immediately upon receiving notification if the time before the scheduled court appearance is less than 7 days. If you are hearing or voice impaired, call 711 to reach the Telecommunications Relay Service.
TIFFANY MOORE RUSSELL
CLERK OF THE CIRCUIT COURT
ORANGE COUNTY, FLORIDA
Sandra Jackson, Deputy Clerk
2020-05-14 12:21:37
425 North Orange Ave.
Suite 350
Orlando, Florida 32801
September 17, 24, 2020 20-03588W

SECOND INSERTION

IN THE CIRCUIT COURT, IN AND FOR ORANGE COUNTY, FLORIDA.
CASE NO.: 20-CA-004030-0 #39 HOLIDAY INN CLUB VACATIONS INCORPORATED F/K/A ORANGE LAKE COUNTRY CLUB, INC. Plaintiff, vs. MCCURDY ET.AL., Defendant(s).

NOTICE OF ACTION
Count X
To: BABETTE M TURLEY AND ANY AND ALL UNKNOWN HEIRS, DEVISEES AND OTHER CLAIMANTS OF BABETTE M. TURLEY
And all parties claiming interest by, through, under or against Defendant(s) BABETTE M TURLEY AND ANY AND ALL UNKNOWN HEIRS, DEVISEES AND OTHER CLAIMANTS OF BABETTE M. TURLEY and all parties having or claiming to have any right, title or interest in the property herein described:
YOU ARE NOTIFIED that an action to foreclose a mortgage/claim of lien on the following described property in Orange County, Florida:
WEEK/UNIT:
5/086264
of Orange Lake Country Club Villas III, a Condominium, together with an undivided interest in the common elements appurtenant thereto, according to the Declaration of Condominium thereof recorded in Official Records Book 5914, Page 1965, in the Public Records of Orange County, Florida, and all amendments thereto; the plat of which is recorded in Condominium Book 28, page 84-92 until 12:00 noon on the first Saturday 2071, at which date said estate shall terminate; TOGETHER with a

remainder over in fee simple absolute as tenant in common with the other owners of all the unit weeks in the above described Condominium in the percentage interest established in the Declaration of Condominium.
has been filed against you and you are required to serve a copy of your written defenses, if any, to it on Jerry E. Aron, Plaintiff's attorney, whose address is 2505 Metrocentre Blvd., Suite 301, West Palm Beach, Florida, 33407, within thirty (30) days after the first publication of this Notice, and file the original with the Clerk of this Court either before service on Plaintiff's attorney or immediately thereafter, otherwise a default will be entered against you for the relief demanded in the Complaint.
If you are a person with disability who needs any accommodation in order to participate in a court proceeding or event, you are entitled, at no cost to you, to the provision of certain assistance. Please contact: in Orange County, ADA Coordinator, Human Resources, Orange County Courthouse, 425 N. Orange Avenue, Suite 510, Orlando, Florida, (407) 836-2303, fax: 407-836-2204; at least 7 days before your scheduled court appearance, or immediately upon receiving notification if the time before the scheduled court appearance is less than 7 days. If you are hearing or voice impaired, call 711 to reach the Telecommunications Relay Service.
TIFFANY MOORE RUSSELL
CLERK OF THE CIRCUIT COURT
ORANGE COUNTY, FLORIDA
Sandra Jackson, Deputy Clerk
2020-05-20 10:21:19
425 North Orange Ave.
Suite 350
Orlando, Florida 32801
September 17, 24, 2020 20-03589W



SAVE TIME

E-mail your Legal Notice
legal@businessobserverfl.com

ORANGE COUNTY
SUBSEQUENT INSERTIONS

SECOND INSERTION

IN THE CIRCUIT COURT, IN AND FOR ORANGE COUNTY, FLORIDA.
CASE NO.: 20-CA-004298-O #39 HOLIDAY INN CLUB VACATIONS INCORPORATED F/K/A ORANGE LAKE COUNTRY CLUB, INC.

Plaintiff, vs. BABIN ET.AL., Defendant(s).

NOTICE OF ACTION
Count V

To: HAYDEE S. INFANTE AND ANY AND ALL UNKNOWN HEIRS, DEVISEES AND OTHER CLAIMANTS OF HAYDEE S. INFANTE and LEONEL FUNDORA AND ANY AND ALL UNKNOWN HEIRS, DEVISEES AND OTHER CLAIMANTS OF LEONEL FUNDORA

And all parties claiming interest by, through, under or against Defendant(s) HAYDEE S. INFANTE AND ANY AND ALL UNKNOWN HEIRS, DEVISEES AND OTHER CLAIMANTS OF HAYDEE S. INFANTE and LEO-

NEL FUNDORA AND ANY AND ALL UNKNOWN HEIRS, DEVISEES AND OTHER CLAIMANTS OF LEONEL FUNDORA and all parties having or claiming to have any right, title or interest in the property herein described: YOU ARE NOTIFIED that an action to foreclose a mortgage/claim of lien on the following described property in Orange County, Florida:

WEEK/UNIT:
27/003811
of Orange Lake Country Club Villas III, a Condominium, together with an undivided interest in the common elements appurtenant thereto, according to the Declaration of Condominium thereof recorded in Official Records Book 5914, Page 1965, in the Public Records of Orange County, Florida, and all amendments thereto; the plat of which is recorded in Condominium Book 28, page 84-92 until 12:00

noon on the first Saturday 2071, at which date said estate shall terminate; TOGETHER with a remainder over in fee simple absolute as tenant in common with the other owners of all the unit weeks in the above described Condominium in the percentage interest established in the Declaration of Condominium.

has been filed against you and you are required to serve a copy of your written defenses, if any, to it on Jerry E. Aron, Plaintiff's attorney, whose address is 2505 Metrocentre Blvd., Suite 301, West Palm Beach, Florida, 33407, within thirty (30) days after the first publication of this Notice, and file the original with the Clerk of this Court either before service on Plaintiff's attorney or immediately thereafter, otherwise a default will be entered against you for the relief demanded in the Complaint.

If you are a person with disability

who needs any accommodation in order to participate in a court proceeding or event, you are entitled, at no cost to you, to the provision of certain assistance. Please contact: in Orange County, ADA Coordinator, Human Resources, Orange County Courthouse, 425 N. Orange Avenue, Suite 510, Orlando, Florida, (407) 836-2303, fax: 407-836-2204; at least 7 days before your scheduled court appearance, or immediately upon receiving notification if the time before the scheduled court appearance is less than 7 days. If you are hearing or voice impaired, call 711 to reach the Telecommunications Relay Service.

TIFFANY MOORE RUSSELL
CLERK OF THE CIRCUIT COURT
ORANGE COUNTY, FLORIDA
Tessa Greene, Deputy Clerk
2020-05-20 15:39:13
425 North Orange Ave.
Suite 350
Orlando, Florida 32801
September 17, 24, 2020 20-03569W

SECOND INSERTION

RE-NOTICE OF FORECLOSURE SALE
IN THE CIRCUIT COURT OF THE NINTH JUDICIAL CIRCUIT, IN AND FOR ORANGE COUNTY, FLORIDA
CIVIL DIVISION

CASE NO.: 2018-CA-009042-O JPMORGAN CHASE BANK, NATIONAL ASSOCIATION Plaintiff, vs.

RONALD W. ROGERS, et al Defendants.

RE-NOTICE IS HEREBY GIVEN pursuant to an Order Granting Plaintiff's Motion to Reschedule Foreclosure Sale entered on August 4, 2020 in Case No. 2018-CA-009042-O of the Circuit Court of the NINTH Judicial Circuit in and for ORANGE COUNTY, Florida, wherein JPMORGAN CHASE BANK, NATIONAL ASSOCIATION, is Plaintiff, and RONALD W. ROGERS, et al are Defendants, the clerk, Tiffany Moore Russell, will sell to the highest and best bidder for cash, beginning at 11:00 AM www.myOrangeClerk.realforeclose.com, in accordance with Chapter 45, Florida Statutes, on the 06 day of October, 2020, the following described property as set forth in said Final Judgment, to wit:

Lot 26, WINDERMERE RESERVE, according to the plat thereof as recorded in Plat Book 27, Page 46, Public Records of Orange County, Florida.

If you are a person claiming a right to funds remaining after the sale, you must file a claim with the clerk no later

than the date that the clerk reports the funds as unclaimed. If you fail to file a claim, you will not be entitled to any remaining funds. After the funds are reported as unclaimed, only the owner of record as of the date of the lis pendens may claim the surplus.

If you are a person with a disability who needs any accommodation to participate in this proceeding, you are entitled, at no cost to you, to the provision of certain assistance. Please contact the ADA Coordinator, Human Resources, Orange County Courthouse, 425 N. Orange Avenue, Suite 510, Orlando, Florida, (407) 836-2303, at least 7 days before your scheduled court appearance, or immediately upon receiving this notification if the time before the scheduled appearance is less than seven (7) days; if you are hearing or voice impaired, call 711.

Dated: September 14, 2020
By: /s/ Heather Griffiths
Phelan Hallinan
Diamond & Jones, PLLC
Heather Griffiths, Esq.,
Florida Bar No. 0091444

Phelan Hallinan Diamond & Jones, PLLC
Attorneys for Plaintiff
2001 NW 64th Street, Suite 100
Ft. Lauderdale, FL 33309
Tel: 954-462-7000
Fax: 954-462-7001
Service by email:
FL.Service@PhelanHallinan.com
PH # 90528
September 17, 24, 2020 20-03607W

SECOND INSERTION

IN THE CIRCUIT COURT, IN AND FOR ORANGE COUNTY, FLORIDA.
CASE NO.: 20-CA-004453-O #39 HOLIDAY INN CLUB VACATIONS INCORPORATED F/K/A ORANGE LAKE COUNTRY CLUB, INC.

Plaintiff, vs. BINKLEY ET.AL., Defendant(s).

NOTICE OF ACTION
Count IV

To: FRANK M CASWELL A/K/A FRANK M. CASWELL, JR. and MARY G. CASWELL AND ANY AND ALL UNKNOWN HEIRS, DEVISEES AND OTHER CLAIMANTS OF MARY G. CASWELL

And all parties claiming interest by, through, under or against Defendant(s) FRANK M CASWELL A/K/A FRANK M. CASWELL, JR. and MARY G. CASWELL AND ANY AND ALL UNKNOWN HEIRS, DEVISEES AND OTHER CLAIMANTS OF MARY G. CASWELL and all parties having or claiming to have any right, title or interest in the property herein described:

YOU ARE NOTIFIED that an action to foreclose a mortgage/claim of lien on the following described property in Orange County, Florida:

WEEK/UNIT:
11/000330
of Orange Lake Country Club Villas I, a Condominium, together with an undivided interest in the common elements appurtenant thereto, according to the Declaration of Condominium thereof recorded in Official Records Book 3300, Page 2702, in the Public Records of Orange County, Florida, and all amendments thereto; the plat of which is recorded in Condominium Book 7, page 59 until 12:00 noon on the first Saturday 2061, at which date said estate shall

terminate; TOGETHER with a remainder over in fee simple absolute as tenant in common with the other owners of all the unit weeks in the above described Condominium in the percentage interest established in the Declaration of Condominium.

has been filed against you and you are required to serve a copy of your written defenses, if any, to it on Jerry E. Aron, Plaintiff's attorney, whose address is 2505 Metrocentre Blvd., Suite 301, West Palm Beach, Florida, 33407, within thirty (30) days after the first publication of this Notice, and file the original with the Clerk of this Court either before service on Plaintiff's attorney or immediately thereafter, otherwise a default will be entered against you for the relief demanded in the Complaint.

If you are a person with disability who needs any accommodation in order to participate in a court proceeding or event, you are entitled, at no cost to you, to the provision of certain assistance. Please contact: in Orange County, ADA Coordinator, Human Resources, Orange County Courthouse, 425 N. Orange Avenue, Suite 510, Orlando, Florida, (407) 836-2303, fax: 407-836-2204; at least 7 days before your scheduled court appearance, or immediately upon receiving notification if the time before the scheduled court appearance is less than 7 days. If you are hearing or voice impaired, call 711 to reach the Telecommunications Relay Service.

TIFFANY MOORE RUSSELL
CLERK OF THE CIRCUIT COURT
ORANGE COUNTY, FLORIDA
Ramona Velez, Deputy Clerk
2020-05-19 08:03:38
425 North Orange Ave.
Suite 350
Orlando, Florida 32801
September 17, 24, 2020 20-03574W

SECOND INSERTION

IN THE CIRCUIT COURT, IN AND FOR ORANGE COUNTY, FLORIDA.
CASE NO.: 20-CA-004051-O #39 HOLIDAY INN CLUB VACATIONS INCORPORATED F/K/A ORANGE LAKE COUNTRY CLUB, INC.

Plaintiff, vs. ABDELAAL ET.AL., Defendant(s).

NOTICE OF ACTION
Count VII

To: IMELDA M. SILVA and MAGDALENO P. SILVA AND ANY AND ALL UNKNOWN HEIRS, DEVISEES AND OTHER CLAIMANTS OF MAGDALENO P. SILVA

And all parties claiming interest by, through, under or against Defendant(s) IMELDA M. SILVA and MAGDALENO P. SILVA AND ANY AND ALL UNKNOWN HEIRS, DEVISEES AND OTHER CLAIMANTS OF MAGDALENO P. SILVA and all parties having or claiming to have any right, title or interest in the property herein described:

YOU ARE NOTIFIED that an action to foreclose a mortgage/claim of lien on the following described property in Orange County, Florida:

WEEK/UNIT:
32/005411
of Orange Lake Country Club Villas II, a Condominium, together with an undivided interest in the common elements appurtenant thereto, according to the Declaration of Condominium thereof recorded in Official Records Book 4846, Page 1619, in the Public Records of Orange County, Florida, and all amendments thereto; the plat of which is recorded in Condominium Book 22, page 132-146 until 12:00 noon on the first Saturday 2061, at which date said estate shall terminate; TO-

GETHER with a remainder over in fee simple absolute as tenant in common with the other owners of all the unit weeks in the above described Condominium in the percentage interest established in the Declaration of Condominium.

has been filed against you and you are required to serve a copy of your written defenses, if any, to it on Jerry E. Aron, Plaintiff's attorney, whose address is 2505 Metrocentre Blvd., Suite 301, West Palm Beach, Florida, 33407, within thirty (30) days after the first publication of this Notice, and file the original with the Clerk of this Court either before service on Plaintiff's attorney or immediately thereafter, otherwise a default will be entered against you for the relief demanded in the Complaint.

If you are a person with disability who needs any accommodation in order to participate in a court proceeding or event, you are entitled, at no cost to you, to the provision of certain assistance. Please contact: in Orange County, ADA Coordinator, Human Resources, Orange County Courthouse, 425 N. Orange Avenue, Suite 510, Orlando, Florida, (407) 836-2303, fax: 407-836-2204; at least 7 days before your scheduled court appearance, or immediately upon receiving notification if the time before the scheduled court appearance is less than 7 days. If you are hearing or voice impaired, call 711 to reach the Telecommunications Relay Service.

TIFFANY MOORE RUSSELL
CLERK OF THE CIRCUIT COURT
ORANGE COUNTY, FLORIDA
Sandra Jackson, Deputy Clerk
2020-07-01 13:14:45
425 North Orange Ave.
Suite 350
Orlando, Florida 32801
September 17, 24, 2020 20-03556W

SECOND INSERTION

NOTICE OF SALE
PURSUANT TO CHAPTER 45
IN THE CIRCUIT COURT OF THE 9TH JUDICIAL CIRCUIT, IN AND FOR ORANGE COUNTY, FLORIDA
CASE NO.

2016-CA-007034-O U.S. BANK TRUST NATIONAL ASSOCIATION, AS TRUSTEE OF THE CABANA SERIES IV TRUST, Plaintiff, v.

JUDITH VELAZQUEZ; JOSE L. VELAZQUEZ; FLTRUST LLC, AS TRUSTEE UNDER THE 8209 SPRING BREEZE LAND TRUSTE DATED 5/5/2015; et al, Defendants.

NOTICE IS HEREBY GIVEN that pursuant to the Final Judgment of Foreclosure entered on August 20, 2020 and entered in Case No. 2016-CA-007034-O in the Circuit Court in and for Orange County, Florida, wherein U.S. BANK TRUST NATIONAL ASSOCIATION, AS TRUSTEE OF THE CABANA SERIES IV TRUST, is Plaintiff, and JUDITH VELAZQUEZ; JOSE L. VELAZQUEZ; FLTRUST LLC, AS TRUSTEE UNDER THE 8209 SPRING BREEZE LAND TRUST DATED 5/5/2015; SECURED CAPITAL TRUST LLC are Defendants, The Clerk of the Court, Tiffany Moore Russell will sell to the highest and best bidder for cash at https://myorangeclerk.realforeclose.com on October 20, 2020 at 11:00 a.m., the following described property as set forth in said Final Judgment, to wit:

LOT 52, SPRING VILLAGE, ACCORDING TO THE PLAT THEREOF AS RECORDED IN PLAT BOOK 28, PAGE 95, PUBLIC RECORDS OF ORANGE COUNTY, FLORIDA.

and commonly known as: 8209 Spring Breeze CT., Orlando, FL 32829 (the "Property").

Any person claiming an interest in the surplus from the sale, if any, other than the property owner as of the date of the lis pendens must file a claim within sixty (60) days after the sale.

"If you are a person with a disability who needs any accommodation in order to participate in a court proceeding or event, you are entitled, at no cost to you, to the provision of certain assistance. Please contact: in Orange County, ADA Coordinator, Human Resources, Orange County Courthouse, 425 N. Orange Avenue, Suite 510, Orlando, Florida, (407) 836-2303, fax: 407-836-2204; and in Osceola County: ADA Coordinator, Court Administration, Osceola County Courthouse, 2 Courthouse Square, Suite 6300, Kissimmee, FL 34741, (407) 742-2417, fax 407-835-5079 at least 7 days before your scheduled court appearance, or immediately upon receiving notification if the time before the scheduled court appearance is less than 7 days. If you are hearing or voice impaired, call 711 to reach the Telecommunications Relay Service."

By: /s/ Tara L. Rosenfeld
Chase A. Berger, Esq.
Florida Bar No.: 083794
Tara L. Rosenfeld, Esq.
Florida Bar No. 0059454

fcpleadings@ghidottiberger.com
GHIDOTTI | BERGER LLP
Attorneys for the Plaintiff
1031 North Miami Beach Blvd
North Miami Beach, FL 33162
Telephone: (305) 501.2808
Fax: (954) 780.5578
September 17, 24, 2020 20-03605W

SECOND INSERTION

IN THE CIRCUIT COURT, IN AND FOR ORANGE COUNTY, FLORIDA.
CASE NO.: 20-CA-004051-O #39 HOLIDAY INN CLUB VACATIONS INCORPORATED F/K/A ORANGE LAKE COUNTRY CLUB, INC.

Plaintiff, vs. ABDELAAL ET.AL., Defendant(s).

NOTICE OF ACTION
Count II

To: MARK K ADKINS and BRENDA S ADKINS AND ANY AND ALL UNKNOWN HEIRS, DEVISEES AND OTHER CLAIMANTS OF BRENDA S. ADKINS

And all parties claiming interest by, through, under or against Defendant(s) MARK K ADKINS and BRENDA S ADKINS AND ANY AND ALL UNKNOWN HEIRS, DEVISEES AND OTHER CLAIMANTS OF BRENDA S. ADKINS and all parties having or claiming to have any right, title or interest in the property herein described:

YOU ARE NOTIFIED that an action to foreclose a mortgage/claim of lien on the following described property in Orange County, Florida:

WEEK/UNIT:
42/002561
of Orange Lake Country Club Villas II, a Condominium, together with an undivided interest in the common elements appurtenant thereto, according to the Declaration of Condominium thereof recorded in Official Records Book 4846, Page 1619, in the Public Records of Orange County, Florida, and all amendments thereto; the plat of which is recorded in Condominium Book 22, page 132-146 until 12:00 noon on the first Saturday 2061, at which date said estate shall terminate; TO-

GETHER with a remainder over in fee simple absolute as tenant in common with the other owners of all the unit weeks in the above described Condominium in the percentage interest established in the Declaration of Condominium.

has been filed against you and you are required to serve a copy of your written defenses, if any, to it on Jerry E. Aron, Plaintiff's attorney, whose address is 2505 Metrocentre Blvd., Suite 301, West Palm Beach, Florida, 33407, within thirty (30) days after the first publication of this Notice, and file the original with the Clerk of this Court either before service on Plaintiff's attorney or immediately thereafter, otherwise a default will be entered against you for the relief demanded in the Complaint.

If you are a person with disability who needs any accommodation in order to participate in a court proceeding or event, you are entitled, at no cost to you, to the provision of certain assistance. Please contact: in Orange County, ADA Coordinator, Human Resources, Orange County Courthouse, 425 N. Orange Avenue, Suite 510, Orlando, Florida, (407) 836-2303, fax: 407-836-2204; at least 7 days before your scheduled court appearance, or immediately upon receiving notification if the time before the scheduled court appearance is less than 7 days. If you are hearing or voice impaired, call 711 to reach the Telecommunications Relay Service.

TIFFANY MOORE RUSSELL
CLERK OF THE CIRCUIT COURT
ORANGE COUNTY, FLORIDA
Ramona Velez, Deputy Clerk
2020-05-19 08:48:40
425 North Orange Ave.
Suite 350
Orlando, Florida 32801
September 17, 24, 2020 20-03554W

SECOND INSERTION

IN THE CIRCUIT COURT, IN AND FOR ORANGE COUNTY, FLORIDA.
CASE NO.: 20-CA-004051-O #39 HOLIDAY INN CLUB VACATIONS INCORPORATED F/K/A ORANGE LAKE COUNTRY CLUB, INC.

Plaintiff, vs. ABDELAAL ET.AL., Defendant(s).

NOTICE OF ACTION
Count V

To: LISA A FIELDS BUMBALOUGH and BILL E. BUMBALOUGH AND ANY AND ALL UNKNOWN HEIRS, DEVISEES AND OTHER CLAIMANTS OF BILL E. BUMBALOUGH
And all parties claiming interest by, through, under or against Defendant(s) LISA A FIELDS BUMBALOUGH and BILL E. BUMBALOUGH AND ANY AND ALL UNKNOWN HEIRS, DEVISEES AND OTHER CLAIMANTS OF BILL E. BUMBALOUGH and all parties having or claiming to have any right, title or interest in the property herein described:

YOU ARE NOTIFIED that an action to foreclose a mortgage/claim of lien on the following described property in Orange County, Florida:

WEEK/UNIT:
18/005422
of Orange Lake Country Club Villas II, a Condominium, together with an undivided interest in the common elements appurtenant thereto, according to the Declaration of Condominium thereof recorded in Official Records Book 4846, Page 1619, in the Public Records of Orange County, Florida, and all amendments thereto; the plat of which is recorded in Condominium Book 22, page 132-146 until 12:00 noon on the first Saturday 2061, at which date said estate shall terminate; TO-

GETHER with a remainder over in fee simple absolute as tenant in common with the other owners of all the unit weeks in the above described Condominium in the percentage interest established in the Declaration of Condominium.

has been filed against you and you are required to serve a copy of your written defenses, if any, to it on Jerry E. Aron, Plaintiff's attorney, whose address is 2505 Metrocentre Blvd., Suite 301, West Palm Beach, Florida, 33407, within thirty (30) days after the first publication of this Notice, and file the original with the Clerk of this Court either before service on Plaintiff's attorney or immediately thereafter, otherwise a default will be entered against you for the relief demanded in the Complaint.

If you are a person with disability who needs any accommodation in order to participate in a court proceeding or event, you are entitled, at no cost to you, to the provision of certain assistance. Please contact: in Orange County, ADA Coordinator, Human Resources, Orange County Courthouse, 425 N. Orange Avenue, Suite 510, Orlando, Florida, (407) 836-2303, fax: 407-836-2204; at least 7 days before your scheduled court appearance, or immediately upon receiving notification if the time before the scheduled court appearance is less than 7 days. If you are hearing or voice impaired, call 711 to reach the Telecommunications Relay Service.

TIFFANY MOORE RUSSELL
CLERK OF THE CIRCUIT COURT
ORANGE COUNTY, FLORIDA
Sandra Jackson, Deputy Clerk
2020-05-20 10:36:53
425 North Orange Ave.
Suite 350
Orlando, Florida 32801
September 17, 24, 2020 20-03555W

SECOND INSERTION

NOTICE OF SALE
IN THE CIRCUIT COURT OF THE NINTH JUDICIAL CIRCUIT IN AND FOR ORANGE COUNTY, FLORIDA
CASE NO. 48-2014-CA-008800-O WELLS FARGO BANK, N.A.

Plaintiff, v. BROOKE A. AXTELL A/K/A BROOKE AXTELL; JONATHAN AXTELL A/K/A JONATHAN W. AXTELL; UNKNOWN TENANT 1; UNKNOWN TENANT 2; AND ALL UNKNOWN PARTIES CLAIMING BY, THROUGH, UNDER OR AGAINST THE ABOVE NAMED DEFENDANT(S), WHO (IS/ARE) NOT KNOWN TO BE DEAD OR ALIVE, WHETHER SAID UNKNOWN PARTIES CLAIM AS HEIRS, DEVISEES, GRANTEES, ASSIGNEES, LIENORS, CREDITORS, TRUSTEES, SPOUSES, OR OTHER CLAIMANTS; BROOKSTONE PROPERTY OWNERS ASSOCIATION, INC.; UNITED STATES OF AMERICA, INTERNAL REVENUE SERVICE Defendants.

Notice is hereby given that, pursuant to the Final Judgment of Foreclosure entered on June 22, 2015, in this cause, in the Circuit Court of Orange County, Florida, the office of Tiffany Moore Russell, Clerk of the Circuit Court, shall sell the property situated in Orange County, Florida, described as:

LOT 30, BROOKSTONE UNIT 1, ACCORDING TO THE PLAT THEREOF, RECORDED IN PLAT BOOK 43, PAGES 47 THROUGH 49, OF THE PUBLIC RECORDS OF ORANGE COUNTY, FLORIDA.

a/k/a 418 COVERED BRIDGE DR, OCOEE, FL 34761-3357 at public sale, to the highest and best bidder, for cash, online at www.myorangeclerk.realforeclose.com, on October 06, 2020 beginning at 11:00 AM.

Any person claiming an interest in the surplus from the sale, if any, other than the property owner as of the date of the lis pendens must file a claim before the clerk reports the surplus as unclaimed.

If you are a person with a disability who needs any accommodation in order to participate in a court proceeding or event, you are entitled, at no cost to you, to the provision of certain assistance. Please contact the ADA Coordinator, Human Resources, Orange County Courthouse, 425 N. Orange Avenue, Suite 510, Orlando, Florida, (407) 836-2303, fax: 407-836-2204 at least 7 days before your scheduled court appearance, or immediately upon receiving notification if the time before the scheduled court appearance is less than 7 days. If you are hearing or voice impaired, call 711 to reach the Telecommunications Relay Service.

Dated at St. Petersburg, Florida this 9 day of September, 2020.
By: David Reider
FL Bar: 95719

eXL Legal, PLLC
Designated Email Address:
efiling@exlegal.com
12425 28th Street North,
Suite 200
St. Petersburg, FL 33716
Telephone No. (727) 536-4911
Attorney for the Plaintiff
888140528
September 17, 24, 2020 20-03604W

HOW TO PUBLISH YOUR

LEGAL NOTICE
IN THE BUSINESS OBSERVER

CALL 941-906-9386

and select the appropriate County name from the menu option
OR
e-mail legal@businessobserverfl.com

Business
Observer
11/2024P

ORANGE COUNTY
SUBSEQUENT INSERTIONS

SECOND INSERTION
NOTICE OF APPLICATION FOR TAX DEED
NOTICE IS HEREBY GIVEN that FIG FL18 LLC the holder of the following certificate has filed said certificate for a TAX DEED to be issued thereon. The Certificate number and year of issuance, the description of the property, and the names in which it was assessed are as follows:

CERTIFICATE NUMBER: 2018-18408

YEAR OF ISSUANCE: 2018

DESCRIPTION OF PROPERTY: REGENT PARK CONDOMINIUM PHASE 9 9507/3803 UNIT 1704 BLDG 17

PARCEL ID # 29-22-31-7382-01-704

Name in which assessed: MEGAN E MITENIUS, THERION C SLACK

ALL of said property being in the County of Orange, State of Florida. Unless such certificate shall be redeemed according to law, the property described in such certificate will be sold to the highest bidder online at www.orange.realtaxdeed.com scheduled to begin at 10:00 a.m. ET, Oct 29, 2020.

Dated: Sep 10, 2020
Phil Diamond
County Comptroller
Orange County, Florida
By: M Hildebrandt
Deputy Comptroller
Sep. 17, 24; Oct. 1, 8, 2020

20-03541W

SECOND INSERTION
NOTICE OF APPLICATION FOR TAX DEED
NOTICE IS HEREBY GIVEN that FIG FL18 LLC the holder of the following certificate has filed said certificate for a TAX DEED to be issued thereon. The Certificate number and year of issuance, the description of the property, and the names in which it was assessed are as follows:

CERTIFICATE NUMBER: 2018-19245

YEAR OF ISSUANCE: 2018

DESCRIPTION OF PROPERTY: UNRECORDED PLAT EAST ORLANDO GATEWAY ANNEX LOT M DESC AS W 110 FT OF E 220 FT OF N 130 FT OF S 165 FT OF NW1/4 OF NW1/4 OF SEC 28-22-32

PARCEL ID # 21-22-32-2337-01-710

Name in which assessed: ELIZABETH HART-HORN ESTATE

ALL of said property being in the County of Orange, State of Florida. Unless such certificate shall be redeemed according to law, the property described in such certificate will be sold to the highest bidder online at www.orange.realtaxdeed.com scheduled to begin at 10:00 a.m. ET, Oct 29, 2020.

Dated: Sep 10, 2020
Phil Diamond
County Comptroller
Orange County, Florida
By: M Hildebrandt
Deputy Comptroller
Sep. 17, 24; Oct. 1, 8, 2020

20-03547W

SECOND INSERTION
NOTICE OF APPLICATION FOR TAX DEED
NOTICE IS HEREBY GIVEN that FIG FL18 LLC the holder of the following certificate has filed said certificate for a TAX DEED to be issued thereon. The Certificate number and year of issuance, the description of the property, and the names in which it was assessed are as follows:

CERTIFICATE NUMBER: 2018-20406

YEAR OF ISSUANCE: 2018

DESCRIPTION OF PROPERTY: CHRISTMAS PARK FIRST ADDITION Y/44 LOT 4 BLK A SEE 5183/3477

PARCEL ID # 34-22-33-1327-01-040

Name in which assessed: GARY BENSON, ANGELA BENSON

ALL of said property being in the County of Orange, State of Florida. Unless such certificate shall be redeemed according to law, the property described in such certificate will be sold to the highest bidder online at www.orange.realtaxdeed.com scheduled to begin at 10:00 a.m. ET, Oct 29, 2020.

Dated: Sep 10, 2020
Phil Diamond
County Comptroller
Orange County, Florida
By: M Hildebrandt
Deputy Comptroller
Sep. 17, 24; Oct. 1, 8, 2020

20-03553W

SECOND INSERTION
NOTICE OF APPLICATION FOR TAX DEED
NOTICE IS HEREBY GIVEN that LIEGE TAX LIENS LLC 18 the holder of the following certificate has filed said certificate for a TAX DEED to be issued thereon. The Certificate number and year of issuance, the description of the property, and the names in which it was assessed are as follows:

CERTIFICATE NUMBER: 2018-18558

YEAR OF ISSUANCE: 2018

DESCRIPTION OF PROPERTY: STONEYBROOK UNIT 1 37/140 LOT 48 BLK 8

PARCEL ID # 02-23-31-1980-80-480

Name in which assessed: WILLIAM MARTINEZ

ALL of said property being in the County of Orange, State of Florida. Unless such certificate shall be redeemed according to law, the property described in such certificate will be sold to the highest bidder online at www.orange.realtaxdeed.com scheduled to begin at 10:00 a.m. ET, Oct 29, 2020.

Dated: Sep 10, 2020
Phil Diamond
County Comptroller
Orange County, Florida
By: M Hildebrandt
Deputy Comptroller
Sep. 17, 24; Oct. 1, 8, 2020

20-03542W

SECOND INSERTION
NOTICE OF APPLICATION FOR TAX DEED
NOTICE IS HEREBY GIVEN that FIG FL18 LLC the holder of the following certificate has filed said certificate for a TAX DEED to be issued thereon. The Certificate number and year of issuance, the description of the property, and the names in which it was assessed are as follows:

CERTIFICATE NUMBER: 2018-19892

YEAR OF ISSUANCE: 2018

DESCRIPTION OF PROPERTY: CAPE ORLANDO ESTATES UNIT 31A 3/110 LOT 15 BLK 2

PARCEL ID # 02-23-32-1221-20-150

Name in which assessed: JAY A MCWILLIAMS, TERESA MCWILLIAMS

ALL of said property being in the County of Orange, State of Florida. Unless such certificate shall be redeemed according to law, the property described in such certificate will be sold to the highest bidder online at www.orange.realtaxdeed.com scheduled to begin at 10:00 a.m. ET, Oct 29, 2020.

Dated: Sep 10, 2020
Phil Diamond
County Comptroller
Orange County, Florida
By: M Hildebrandt
Deputy Comptroller
Sep. 17, 24; Oct. 1, 8, 2020

20-03548W

SECOND INSERTION
NOTICE OF FORECLOSURE SALE PURSUANT TO CHAPTER 45 IN THE CIRCUIT COURT OF THE NINTH JUDICIAL CIRCUIT IN AND FOR ORANGE COUNTY, FLORIDA CASE NO.: 2019-CA-007545-O
BRANCH BANKING AND TRUST COMPANY, Plaintiff, VS. BESSIE M. ENMOND; et al., Defendant(s).
NOTICE IS HEREBY GIVEN that sale will be made pursuant to an Order or Final Judgment. Final Judgment was awarded on November 25, 2019 in Civil Case No. 2019-CA-007545-O, of the Circuit Court of the NINTH Judicial Circuit in and for Orange County, Florida, wherein, BRANCH BANKING AND TRUST COMPANY is the Plaintiff, and BESSIE M. ENMOND; LEND-MARK FINANCIAL SERVICES, INC.; UNKNOWN TENANT 1 N/K/A EUGENE INMON; ANY AND ALL UNKNOWN PARTIES CLAIMING BY, THROUGH, UNDER AND AGAINST THE HEREIN NAMED INDIVIDUAL DEFENDANT(S) WHO ARE NOT KNOWN TO BE DEAD OR ALIVE, WHETHER SAID UNKNOWN PARTIES MAY CLAIM AN INTEREST AS SPOUSES, HEIRS, DEVISEES, GRANTEES, OR OTHER CLAIMANTS are Defendants.
The Clerk of the Court, Tiffany Moore Russell will sell to the highest bidder for cash at www.myorangedclerk.realforeclose.com on October 20, 2020 at 11:00:00 AM EST the following described real property as set forth in said Final Judgment, to wit:
LOT 82, MALIBU GROVES, ELEVENTH ADDITION, ACCORDING TO A PLAT THEREOF, AS RECORDED IN PLAT BOOK 4, PAGES 87 AND 88, IN THE PUBLIC RECORDS OF OR-

SECOND INSERTION
NOTICE OF APPLICATION FOR TAX DEED
NOTICE IS HEREBY GIVEN that LIEGE TAX LIENS LLC 18 the holder of the following certificate has filed said certificate for a TAX DEED to be issued thereon. The Certificate number and year of issuance, the description of the property, and the names in which it was assessed are as follows:

CERTIFICATE NUMBER: 2018-18582

YEAR OF ISSUANCE: 2018

DESCRIPTION OF PROPERTY: STONEWOOD ESTATES AT CYPRESS SPRINGS 2 42/63 LOT 52

PARCEL ID # 05-23-31-1976-00-520

Name in which assessed: ELISEO RIVERA SR, MYRNA RIVERA

ALL of said property being in the County of Orange, State of Florida. Unless such certificate shall be redeemed according to law, the property described in such certificate will be sold to the highest bidder online at www.orange.realtaxdeed.com scheduled to begin at 10:00 a.m. ET, Oct 29, 2020.

Dated: Sep 10, 2020
Phil Diamond
County Comptroller
Orange County, Florida
By: M Hildebrandt
Deputy Comptroller
Sep. 17, 24; Oct. 1, 8, 2020

20-03543W

SECOND INSERTION
NOTICE OF APPLICATION FOR TAX DEED
NOTICE IS HEREBY GIVEN that FIG FL18 LLC the holder of the following certificate has filed said certificate for a TAX DEED to be issued thereon. The Certificate number and year of issuance, the description of the property, and the names in which it was assessed are as follows:

CERTIFICATE NUMBER: 2018-19907

YEAR OF ISSUANCE: 2018

DESCRIPTION OF PROPERTY: CAPE ORLANDO ESTATES UNIT 31A 3/110 LOT 49 BLK 5

PARCEL ID # 02-23-32-1221-50-490

Name in which assessed: THEODORE H ZAMBELIS

ALL of said property being in the County of Orange, State of Florida. Unless such certificate shall be redeemed according to law, the property described in such certificate will be sold to the highest bidder online at www.orange.realtaxdeed.com scheduled to begin at 10:00 a.m. ET, Oct 29, 2020.

Dated: Sep 10, 2020
Phil Diamond
County Comptroller
Orange County, Florida
By: M Hildebrandt
Deputy Comptroller
Sep. 17, 24; Oct. 1, 8, 2020

20-03549W

SECOND INSERTION
ANGE COUNTY, FLORIDA.
Any person claiming an interest in the surplus from the sale, if any, other than the property owner as of the date of the lis pendens must file a claim before the clerk reports the surplus as unclaimed.
IMPORTANT AMERICANS WITH DISABILITIES ACT: AMERICANS WITH DISABILITIES ACT: If you are a person with a disability who needs any accommodation in order to participate in a court proceeding or event, you are entitled, at no cost to you, to the provision of certain assistance. Please contact Orange County, ADA Coordinator, Human Resources, Orange County Courthouse, 425 N. Orange Avenue, Suite 510, Orlando, Florida, (407) 836-2303, fax: 407-836-2204; and in Osceola County: ADA Coordinator, Court Administration, Osceola County Courthouse, 2 Courthouse Square, Suite 6300, Kissimmee, FL 34741, (407) 742-2417, fax 407-835-5079, at least 7 days before your scheduled court appearance, or immediately upon receiving notification if the time before the scheduled court appearance is less than 7 days. If you are hearing or voice impaired, call 711 to reach the Telecommunications Relay Service.
Dated this 11 day of September, 2020.
Digitally signed by Zachary Ullman
Date: 2020-09-11 13:10:54
FBN: 106751
Primary E-Mail: ServiceMail@aldridgepите.com
ALDRIDGE | PITE, LLP
Attorney for Plaintiff
1615 South Congress Avenue Suite 200
Delray Beach, FL 33445
Telephone: 561-392-6391
Facsimile: 561-392-6965
1212-1327B
September 17, 24, 2020 20-03603W

SECOND INSERTION
NOTICE OF APPLICATION FOR TAX DEED
NOTICE IS HEREBY GIVEN that FIG FL18 LLC the holder of the following certificate has filed said certificate for a TAX DEED to be issued thereon. The Certificate number and year of issuance, the description of the property, and the names in which it was assessed are as follows:

CERTIFICATE NUMBER: 2018-19049

YEAR OF ISSUANCE: 2018

DESCRIPTION OF PROPERTY: UNRECORDED PLAT EAST ORLANDO ESTATES SECTION 1 TR 14 THE N1/2 OF THE FOLLOWING DESC PARCEL FROM A POINT ON THE W LINE OF SEC 22-22-32 RUN S 813.24 FT OF W1/4 COR OF SAID SEC E 608.15 FT S 180.36 FT TOR POB CONT S 207 FT E 518.27 FT N 18 DEG W 217.94 FT W 450.10 FT TO POB

PARCEL ID # 15-22-32-2336-00-140

Name in which assessed: MARGARET ALLISON CORRELL

ALL of said property being in the County of Orange, State of Florida. Unless such certificate shall be redeemed according to law, the property described in such certificate will be sold to the highest bidder online at www.orange.realtaxdeed.com scheduled to begin at 10:00 a.m. ET, Oct 29, 2020.

Dated: Sep 10, 2020
Phil Diamond
County Comptroller
Orange County, Florida
By: M Hildebrandt
Deputy Comptroller
Sep. 17, 24; Oct. 1, 8, 2020

20-03544W

SECOND INSERTION
NOTICE OF APPLICATION FOR TAX DEED
NOTICE IS HEREBY GIVEN that FIG FL18 LLC the holder of the following certificate has filed said certificate for a TAX DEED to be issued thereon. The Certificate number and year of issuance, the description of the property, and the names in which it was assessed are as follows:

CERTIFICATE NUMBER: 2018-20026

YEAR OF ISSUANCE: 2018

DESCRIPTION OF PROPERTY: CAPE ORLANDO ESTATES UNIT 12A 4/66 LOT 12 BLK 18

PARCEL ID # 10-23-32-1184-18-120

Name in which assessed: ALVIN J CHODORA, IRENE R CHODORA

ALL of said property being in the County of Orange, State of Florida. Unless such certificate shall be redeemed according to law, the property described in such certificate will be sold to the highest bidder online at www.orange.realtaxdeed.com scheduled to begin at 10:00 a.m. ET, Oct 29, 2020.

Dated: Sep 10, 2020
Phil Diamond
County Comptroller
Orange County, Florida
By: M Hildebrandt
Deputy Comptroller
Sep. 17, 24; Oct. 1, 8, 2020

20-03550W

SECOND INSERTION
NOTICE OF FORECLOSURE SALE PURSUANT TO CHAPTER 45 IN THE CIRCUIT COURT OF THE NINTH JUDICIAL CIRCUIT IN AND FOR ORANGE COUNTY, FLORIDA CASE NO.: 2019-CA-007935-O
WELLS FARGO BANK, NATIONAL ASSOCIATION, AS TRUSTEE, ON BEHALF OF THE REGISTERED HOLDERS OF MORGAN STANLEY ABS CAPITAL I INC. TRUST 2007-HE4, MORTGAGE PASS-THROUGH CERTIFICATES, SERIES 2007- HE4, Plaintiff, VS. LAMEISICIA L. CURRY A/K/A LAMEISICIA L. CURRY; et al Defendant(s).
NOTICE IS HEREBY GIVEN that sale will be made pursuant to an Order or Final Judgment. Final Judgment was awarded on February 27, 2020 in Civil Case No. 2019-CA-007935-O, of the Circuit Court of the NINTH Judicial Circuit in and for Orange County, Florida, wherein, WELLS FARGO BANK, NATIONAL ASSOCIATION, AS TRUSTEE, ON BEHALF OF THE REGISTERED HOLDERS OF MORGAN STANLEY ABS CAPITAL I INC. TRUST 2007-HE4, MORTGAGE PASS-THROUGH CERTIFICATES, SERIES 2007- HE4 is the Plaintiff, and LAMEISICIA L. CURRY A/K/A LAMEISICIA L. CURRY; UNKNOWN SPOUSE OF LAMEISICIA CURRY; HUNTER'S CREEK COM-

SECOND INSERTION
NOTICE OF APPLICATION FOR TAX DEED
NOTICE IS HEREBY GIVEN that FIG FL18 LLC the holder of the following certificate has filed said certificate for a TAX DEED to be issued thereon. The Certificate number and year of issuance, the description of the property, and the names in which it was assessed are as follows:

CERTIFICATE NUMBER: 2018-19069

YEAR OF ISSUANCE: 2018

DESCRIPTION OF PROPERTY: UNRECORDED PLAT EAST ORLANDO ESTATES SECTION 1 TR 65 DESC AS BEG 139.96 FT S S 18 DEG E 1584.72 FT N 72 DEG E 262.46 FT & 240 FT E FROM NW COR OF SEC 22 22 32 E 240 FT S 420 FT W 240 FT N 420 FT TO POB (LESS W1/2 THEREOF)

PARCEL ID # 15-22-32-2336-00-650

Name in which assessed: JACK ARNOLD YANDLE JR, RHONDA K MARTIN

ALL of said property being in the County of Orange, State of Florida. Unless such certificate shall be redeemed according to law, the property described in such certificate will be sold to the highest bidder online at www.orange.realtaxdeed.com scheduled to begin at 10:00 a.m. ET, Oct 29, 2020.

Dated: Sep 10, 2020
Phil Diamond
County Comptroller
Orange County, Florida
By: M Hildebrandt
Deputy Comptroller
Sep. 17, 24; Oct. 1, 8, 2020

20-03545W

SECOND INSERTION
NOTICE OF APPLICATION FOR TAX DEED
NOTICE IS HEREBY GIVEN that FIG FL18 LLC the holder of the following certificate has filed said certificate for a TAX DEED to be issued thereon. The Certificate number and year of issuance, the description of the property, and the names in which it was assessed are as follows:

CERTIFICATE NUMBER: 2018-20241

YEAR OF ISSUANCE: 2018

DESCRIPTION OF PROPERTY: CAPE ORLANDO ESTATES UNIT 7A 3/103 LOT 53 BLK 2

PARCEL ID # 26-23-32-1173-20-530

Name in which assessed: REINALDO DELVALLE, BRENDA I DELVALLE

ALL of said property being in the County of Orange, State of Florida. Unless such certificate shall be redeemed according to law, the property described in such certificate will be sold to the highest bidder online at www.orange.realtaxdeed.com scheduled to begin at 10:00 a.m. ET, Oct 29, 2020.

Dated: Sep 10, 2020
Phil Diamond
County Comptroller
Orange County, Florida
By: M Hildebrandt
Deputy Comptroller
Sep. 17, 24; Oct. 1, 8, 2020

20-03551W

SECOND INSERTION
MUNITY ASSOCIATION, INC.; UNKNOWN TENANT 1; UNKNOWN TENANT 2; ANY AND ALL UNKNOWN PARTIES CLAIMING BY, THROUGH, UNDER AND AGAINST THE HEREIN NAMED INDIVIDUAL DEFENDANT(S) WHO ARE NOT KNOWN TO BE DEAD OR ALIVE, WHETHER SAID UNKNOWN PARTIES MAY CLAIM AN INTEREST AS SPOUSES, HEIRS, DEVISEES, GRANTEES, OR OTHER CLAIMANTS are Defendants.
The Clerk of the Court, Tiffany Moore Russell will sell to the highest bidder for cash at www.myorangedclerk.realforeclose.com on October 20, 2020 at 11:00:00 AM EST the following described real property as set forth in said Final Judgment, to wit:
LOT 87, HUNTER'S CREEK TRACT 550, ACCORDING TO THE MAP OR PLAT THEREOF, AS RECORDED IN PLAT BOOK 37, PAGES 35-36, OF THE PUBLIC RECORDS OF ORANGE COUNTY, FLORIDA.
Any person claiming an interest in the surplus from the sale, if any, other than the property owner as of the date of the lis pendens must file a claim before the clerk reports the surplus as unclaimed.
IMPORTANT AMERICANS WITH DISABILITIES ACT: AMERICANS WITH DISABILITIES ACT: If you are a person with a disability who needs any accommoda-

SECOND INSERTION
NOTICE OF APPLICATION FOR TAX DEED
NOTICE IS HEREBY GIVEN that FIG FL18 LLC the holder of the following certificate has filed said certificate for a TAX DEED to be issued thereon. The Certificate number and year of issuance, the description of the property, and the names in which it was assessed are as follows:

CERTIFICATE NUMBER: 2018-19100

YEAR OF ISSUANCE: 2018

DESCRIPTION OF PROPERTY: UNRECORDED PLAT EAST ORLANDO ESTATES SECTION 1 TR 190 DESC AS BEG 2322.4 FT N & 4712.85 FT E FROM W 1/4 COR OF SEC 22-22-32 N 150 FT E 295 FT S 150 FT W 295 FT TO POB

PARCEL ID # 15-22-32-2336-01-900

Name in which assessed: KAREN M CAMPBELL

ALL of said property being in the County of Orange, State of Florida. Unless such certificate shall be redeemed according to law, the property described in such certificate will be sold to the highest bidder online at www.orange.realtaxdeed.com scheduled to begin at 10:00 a.m. ET, Oct 29, 2020.

Dated: Sep 10, 2020
Phil Diamond
County Comptroller
Orange County, Florida
By: M Hildebrandt
Deputy Comptroller
Sep. 17, 24; Oct. 1, 8, 2020

20-03546W

SECOND INSERTION
NOTICE OF APPLICATION FOR TAX DEED
NOTICE IS HEREBY GIVEN that FIG FL18 LLC the holder of the following certificate has filed said certificate for a TAX DEED to be issued thereon. The Certificate number and year of issuance, the description of the property, and the names in which it was assessed are as follows:

CERTIFICATE NUMBER: 2018-20248

YEAR OF ISSUANCE: 2018

DESCRIPTION OF PROPERTY: CAPE ORLANDO ESTATES UNIT 7A 3/103 LOT 20 BLK 3

PARCEL ID # 26-23-32-1173-30-200

Name in which assessed: RAYMOND A NICOLOSI

ALL of said property being in the County of Orange, State of Florida. Unless such certificate shall be redeemed according to law, the property described in such certificate will be sold to the highest bidder online at www.orange.realtaxdeed.com scheduled to begin at 10:00 a.m. ET, Oct 29, 2020.

Dated: Sep 10, 2020
Phil Diamond
County Comptroller
Orange County, Florida
By: M Hildebrandt
Deputy Comptroller
Sep. 17, 24; Oct. 1, 8, 2020

20-03552W

SECOND INSERTION
tion in order to participate in a court proceeding or event, you are entitled, at no cost to you, to the provision of certain assistance. Please contact Orange County, ADA Coordinator, Human Resources, Orange County Courthouse, 425 N. Orange Avenue, Suite 510, Orlando, Florida, (407) 836-2303, fax: 407-836-2204; and in Osceola County: ADA Coordinator, Court Administration, Osceola County Courthouse, 2 Courthouse Square, Suite 6300, Kissimmee, FL 34741, (407) 742-2417, fax 407-835-5079, at least 7 days before your scheduled court appearance, or immediately upon receiving notification if the time before the scheduled court appearance is less than 7 days. If you are hearing or voice impaired, call 711 to reach the Telecommunications Relay Service.
Dated this 11 day of Sept., 2020.
Digitally signed by Jennifer Travieso
Date: 2020-09-11 13:50:20
Florida Bar #641065
Primary E-Mail: ServiceMail@aldridgepите.com
ALDRIDGE | PITE, LLP
Attorney for Plaintiff
1615 South Congress Avenue
Suite 200
Delray Beach, FL 33445
Telephone: 561-392-6391
Facsimile: 561-392-6965
1012-3251B
September 17, 24, 2020 20-03602W

ORANGE COUNTY
SUBSEQUENT INSERTIONS

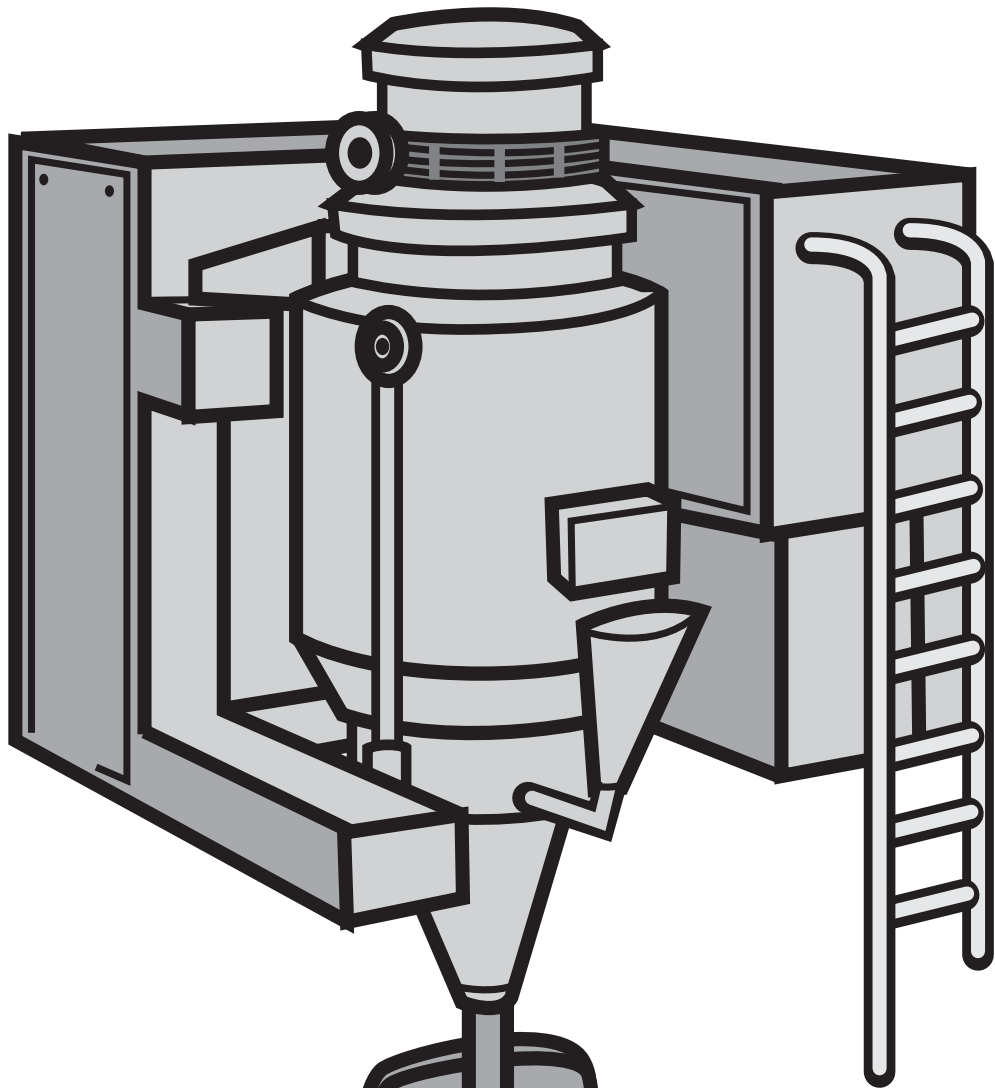

A special printing of a classic story illustrating the importance of protecting capitalism.

TOM SMITH AND HIS INCREDIBLE BREAD MACHINE

By R.W. Grant

Illustrations by Austin McKinley

This is the legend of a man whose name
Was a household word: a man whose fame
Burst on the world like an atom bomb.
Smith was his last name; first name: Tom.

The argument goes on today.
"He was a villain," some will say.
"No! A hero!" others declare.
Or was he both? Well, I despair;
The fight will last 'til kingdom come;
Was Smith a hero? Or was Smith a bum?
So, listen to the story and it's up to you
To decide for yourself as to which is true!

Now, Smith, an inventor, had specialized
In toys. So people were surprised
When they found that he instead
Of making toys, was baking bread!
The news was flashed by CBS
Of his incredible success.
Then NBC jumped in in force,
Followed by the Times, of course.
The reason for their rapt attention,
The nature of his new invention,
The way to make bread he'd conceived
Cost less than people could believe!
And not just make it! This device
Could in addition wrap and slice!
The price per loaf, one loaf or many:
The miniscule sum of under one penny!

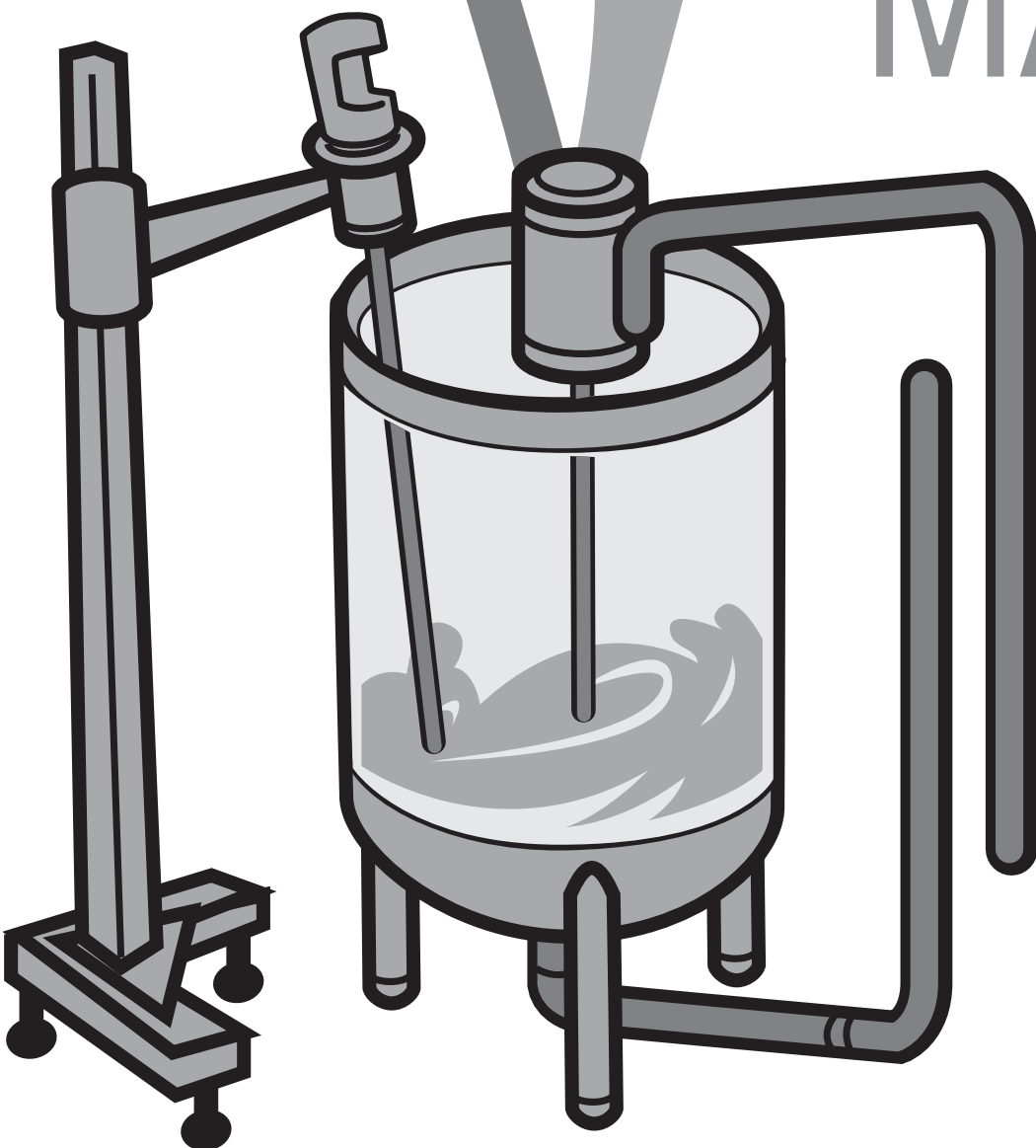

ORANGE COUNTY
SUBSEQUENT INSERTIONS

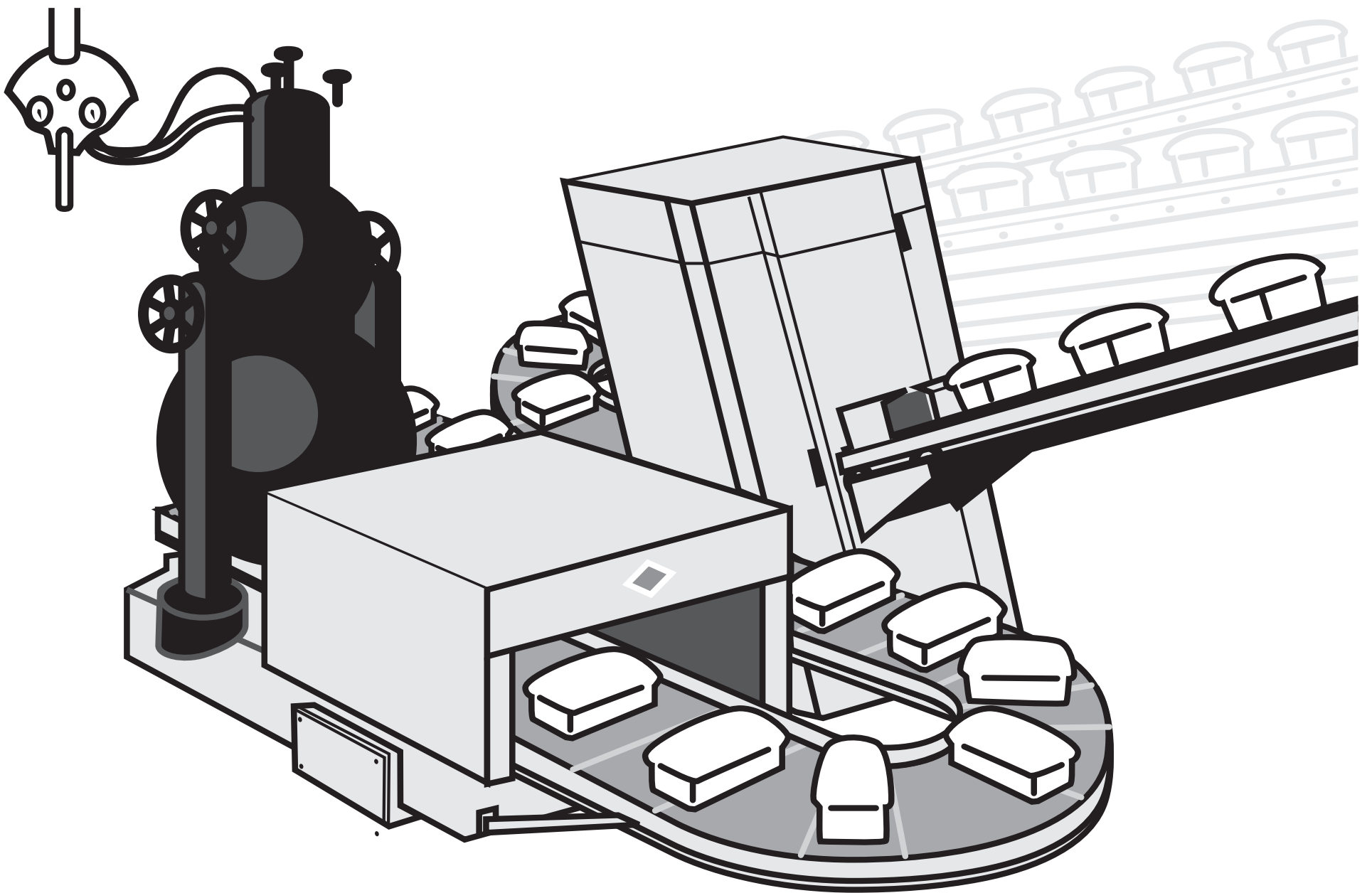

Can you imagine what this meant?
Can you comprehend the consequent?
The first time yet the world well fed!
And all because of Tom Smith's bread!

Not the last to see the repercussions
Were the Red Chinese, and, of course, the
Russians,
For Capitalist bread in such array

Threw the whole red block into black dis-
may!
Nonetheless, the world soon found
That bread was plentiful the world
around.
Thanks to Smith and all that bread,
A grateful world was at last well fed!

But isn't it a wondrous thing
How quickly fame is flown?
Smith, the hero of today
Tomorrow, scarcely known!
Yes, the fickle years passed by.
Smith was a billionaire.

But Smith himself was now forgot,
Though bread was everywhere.
People, asked from where it came,
Would very seldom know.

They would simply eat and ask,
'Was not it always so?'

However, Smith cared not a bit,
For millions ate his bread,
And "Everything is fine," thought he.
"I'm rich and they are fed!"

Everything was fine, he thought?
He reckoned not with fate.
Note the sequence of events
Starting on the date
On which inflation took its toll,
And to a slight extent,
The price on every loaf increased:
It went to one full cent!

A sharp reaction quickly came.
People were concerned.
White House aide expressed dismay.
Then the nation learned
That Russia lodged a sharp protest.
India did the same.
"Exploitation of the Poor!"
Yet, who was there to blame?

And though the clamor ebbed and flowed,
All that Tom would say
Was that it was but foolish talk.
Which soon would die away.
And it appeared that he was right.
Though on and on it ran,
The argument went 'round and 'round
But stopped where it began.

There it stopped, and people cried,
"For heaven's sake, we can't decide!
It's relative! Beyond dispute,
There's no such thing as 'absolute'!
And though we try with all our might,
Since nothing's ever black or white,
All that we can finally say is
'Everything one shade of grey is!'
So people cried out, "Give us light!
We can't tell what's wrong from right!"

To comprehend confusion,
We seek wisdom at its source.
To whom, then did the people turn?
The Intellectuals, of course!

And what could be a better time
For them to take the lead,
Than at their International Conference
On Inhumanity and Greed.
For at this weighty conference,
Once each year we face
The moral conscience of the world—
Concentrated in one place.

At that mighty conference were
A thousand, more or less,
Of intellectuals and bureaucrats,
And those who write the press.
And from Yale and Harvard
The professors; all aware
The fate of Smith would now be known.
Excitement filled the air!

"The time has come," the chairman said
"To speak of many things:
Of duty, bread and selfishness,
And the evil that it brings.
For, speaking thus we can amend
That irony of fate
That gives to unenlightened minds
The power to create.



ORANGE COUNTY
SUBSEQUENT INSERTIONS

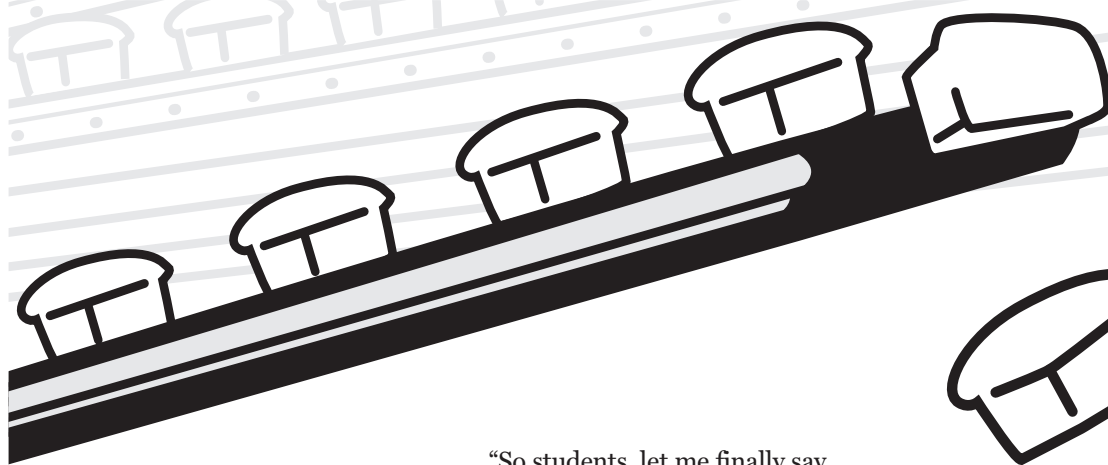

“Since reason tells us that it can’t,
Therefore let us start
Not by thinking with the mind,
But only with the heart!
Since we believe in people, then,
At last the chairman said,
‘We must meet our obligation
To see that they are fed!’”

And so it went, one by one,
Denouncing private greed;
Denouncing those who’d profit thus
From other people’s need!

Then, suddenly each breath was held,
For there was none more wise
Than the nation’s foremost Pundit
Who now rose to summarize:

“My friends,” he said, (they all
exhaled)
‘We see in these events
The flouting of the Higher Law—
And its consequence.
We must again remind ourselves
Just why mankind is cursed:
Because we fail to realize
Society comes first!’

“Smith placed himself above the
group
To profit from his brothers.
He failed to see the Greater Good,
Is Service, friends, to Others!”

With boldness and with vision,
then,
They ratified the motion
To dedicate to all mankind
Smith’s bread-and their devotion!

The conference finally ended.
It had been a huge success.
The intellectuals had spoken.
Now others did the rest.

The professors joined in all the
fuss,
And one was heard to lecture thus:
(For clarity, he spoke in terms
Of Mother Nature, birds and worms):

“That early birds should get the worm
Is clearly quite unfair.
Wouldn’t it much nicer be
If all of them would share?
But selfishness and private greed

Seem part of nature’s plan,
Which Mother Nature has decreed
For bird. But also Man?
The system which I question now,
As you are well aware,
(I’m sure you’ve heard the term
before
Is Business, Laissez-Faire!

“So students, let me finally say
That we must find a nobler way.
So, let us fix the race that all
May finish side-by-side;
The playing field forever flat,
The score forever tied.
To achieve this end, of course,
We turn to government-and force.
So, if we have to bring Smith do
As indeed we should,
I’m sure you will agree with me,
It’s for the Greater Good!”

Comments in the nation’s press
Now scorned Smith and his plunder:
‘What right had he to get so rich
On other people’s hunger?’
A prize cartoon depicted Smith
With fat and drooping jowls
Snatching bread from hungry babes,
Indifferent to their howls.

One night, a TV star cried out,
“Forgive me if I stumble,
But I don’t think, I kid you not,
That Smith is very humble!”
Growing bolder, he leaped up,

(Silencing the cheers)
“Humility!” he cried to all—
And then collapsed in tears!

The clamor rises all about;
Now hear the politician shout:
‘What’s Smith done, so rich to be?
Why should Smith have more than thee?
So, down with Smith and all his greed;
I’ll protect your right to need!’”

Then Tom found to his dismay
That certain businessmen would say,
“The people now should realize
It’s time to cut Smith down to size,
For he’s betrayed his public trust
(And taken all that bread from us!)”

Well, since the Public does come first,
It could not be denied
That in matters such as this,
The public must decide.
So, SEC became concerned,
And told the press what it had learned:
“It’s obvious that he’s guilty
—Of what we’re not aware—
Though actually and factually
We’re sure there’s something there!”

And Antitrust now took a hand.
Of course it was appalled
At what it found was going on.
The “bread trust” it was called.

“Smith has too much crust,”
they said. “A deplorable condition
That Robber Barons profit thus
From cutthroat competition!”

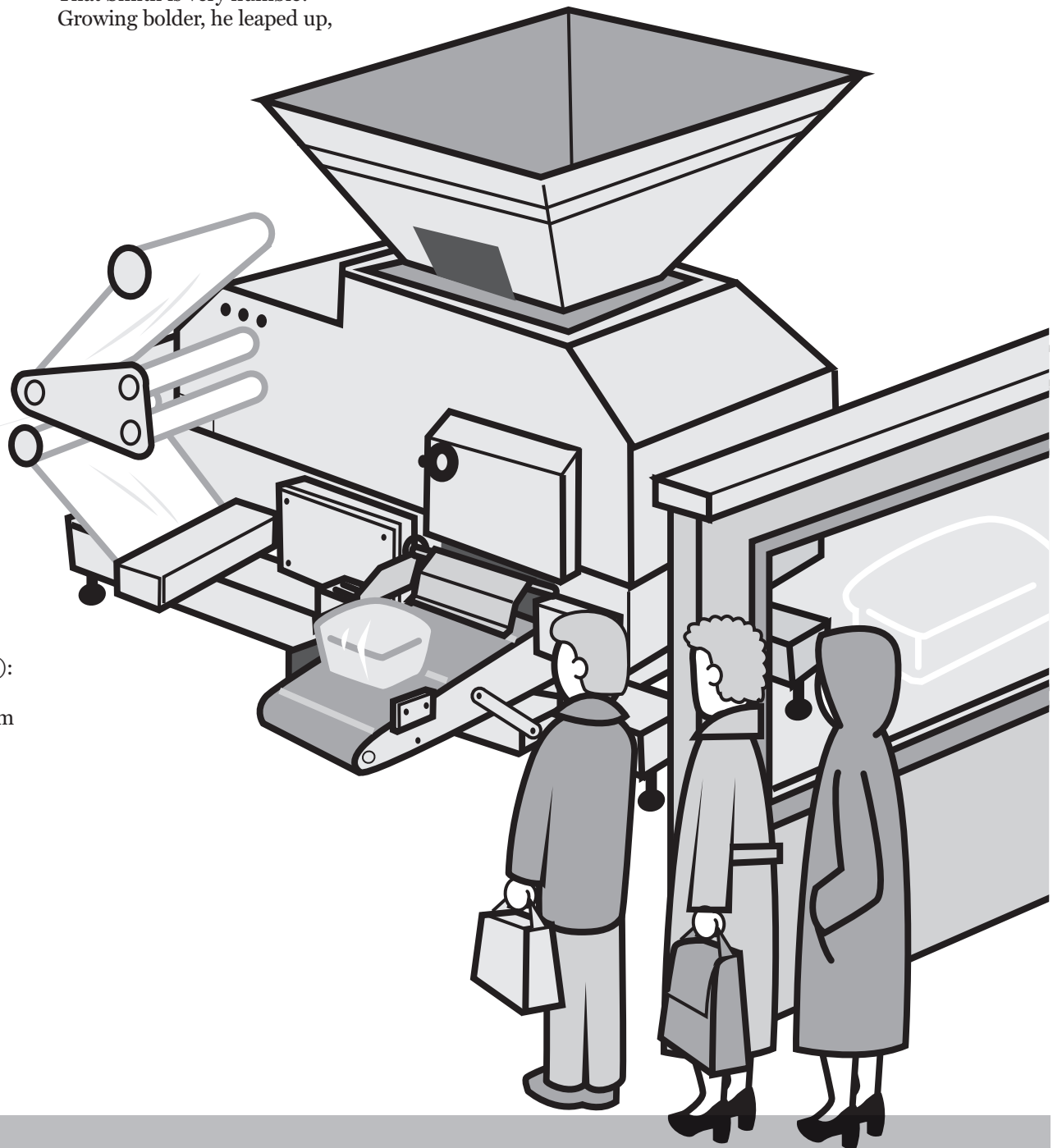
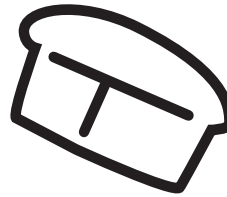
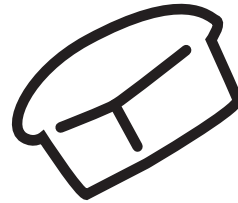

ORANGE COUNTY

SUBSEQUENT INSERTIONS

WELL!

This was getting serious!
So Smith felt that he must
Have a friendly interview
With SEC and ‘Trust.
So, hat in hand, he went to them.
They’d surely been misled;
No rule of law had he defied.
But then their lawyer said:

“The rule of law, in complex times,
Has proved itself deficient.
We much prefer the rule of men.
It’s vastly more efficient.

“So, nutshell-wise, the way it is,
The law is what we say it is!

“So, let me state the present rules,”
The lawyer then went on,
“These very simple guidelines
You can rely upon:
You’re gouging on your prices
If you charge more than the rest.
But it’s unfair competition
If you think you can charge less!
“A second point that we would make,
To help avoid confusion:
Don’t try to charge the same amount,
For that would be collusion!

“You must compete—but not too much.
For if you do, you see,
Then the market would be yours—
And that’s monopoly!
Oh, don’t dare monopolize!
We’d raise an awful fuss,
For that’s the greatest crime of all!
(Unless it’s done by us!)”

“I think I understand,” said Tom.
“And yet, before I go,
How does one get a job like yours?
I’d really like to know!”

The lawyer rose then with a smile;
“I’m glad you asked,” said he.
“I’ll tell you how I got my start
And how it came to be.”

(His secretaries gathered ‘round
As their boss did thus expound.)

*‘When I was a lad going off to school,
I was always guided by this golden rule:
Let others take the lead in things, for
heaven’s sake,
So if things go wrong—why, then it’s their
mistake!’*
(*So if things go wrong—why, then it’s their
mistake!*)

*“Following this precept it came to pass
I became the president of my senior class.
Then on to college where my profs extolled
The very same theory from the very same
mold!”*
(*The very same theory from the very same
mold!*)

*“Let others take the chances, and I would
go along.
Then I would let them know where they all
went wrong!
So successful was my system that then
indeed,
I was voted most likely in my class to suc-
ceed!”*

*(He was voted most likely in his class to
succeed!)*

*“Then out into the world I went, along
with all the rest,
Where I put my golden rule to the ulti-
mate test.
I avoided all of commerce at whatever the
cost—
And because I never ventured, then I also
never lost!”*
(*And because he never ventured, then he
also never lost!*)

*‘With this unblemished record then, I
quickly caught the eye
Of some influential people ‘mongst the
powers on high.*

*And so these many years among the
mighty I have sat,
Having found my niche as a bureaucrat!”*
(*Having found his niche as a bureaucrat!*)

*“To be a merchant prince has never been
my goal,
For I’m qualified to play a more impor-
tant role:
Since I’ve never failed in business, this of
course assures
That I’m qualified beyond dispute to now
run yours!”*
(*That he’s qualified beyond dispute to now
run yours!*)

“Thanks; that clears it up,” said Tom.

The lawyer said, “I’m glad!
We try to serve the public good.
We’re really not so bad!

“Now, in disposing of this case,
If you wish to know just how,
Go up to the seventh floor;
We’re finalizing now!”

So, Tom went to the conference room
Up on the seventh floor.
He raised his hand, about to knock,
He raised it—but no more—
For what he overheard within
Kept him outside the door!
A sentence here, a sentence there—
Every other word—
He couldn’t make it out (he hoped),
For this is what he heard:

“Mumble, mumble, let’s not fumble!
Mumble, mumble, what’s the charge?
Grumble, grumble, he’s not humble?
Private greed? Or good of all?”

“Public Interest, Rah! Rah! Rah!
Business, Business, Bah! Bah! Bah!

“Say, now this now we confess
That now this now is a mess!
Well now, what now do we guess?
Discharge? Which charge would be best?”

“How ‘bout ‘Greed and Selfishness’?
Oh, wouldn’t that be fun?
It’s vague enough to trip him up
No matter what he’s done!

‘We don’t produce or build a thing!
But before we’re through,
We allow that now we’ll show Smith how
We handle those who do!

‘We serve the public interest;
We make up our own laws;
Oh, golly gee, how selflessly
We serve the public cause!

“For we’re the ones who make the rules
At ‘Trust and SEC,
So bye and bye we’ll get that guy;
Now, what charge will it be?”

“Price too high? Or price too low?
Now, which charge will we make?
Well, we’re not loath to charging both
When public good’s at stake!

“But can we go one better?
How ‘bout monopoly?
No muss, no fuss, oh clever us!
Right-O! Let’s charge all three!

“But why stop here? We have one more!
Insider Trading! Number four!
We’ve not troubled to define
This crime in any way so,
This allows the courts to find
Him guilty ‘cause we say so!”

So, that was the indictment.
Smith’s trial soon began.
It was a cause célèbre
Which was followed’ cross the land.
In his defense Tom only said,
“I’m rich, but all of you are fed!
Is that bargain so unjust
That I should now be punished thus?”

Tom fought it hard all the way.
But it didn’t help him win.
The jury took but half an hour
To bring this verdict in:

“Guilty! Guilty! We agree!
He’s guilty of this plunder!
He had no right to get so rich
On other people’s hunger!”

“Five years in jail!” the judge then said.
“You’re lucky it’s not worse!
Robber Barons must be taught
Society Comes First!
As flies to wanton boys,” he leered,
“Are we to men like these!
They exploit us for their sport!
Exploit us as they please!”

The sentence seemed a bit severe,
But mercy was extended.
In deference to his mother’s pleas,
One year was suspended.
And what about the Bread Machine?
Tom Smith’s little friend?
Broken up and sold for scrap.
Some win. Some lose. The end.

EPILOGUE

Now, bread is baked by government.
And as might be expected,
Everything is well controlled—
The public well protected.

True, loaves cost ten dollars each.
But our leaders do their best.
The selling price is half a cent.
Taxes pay the rest!

