

## ORANGE COUNTY LEGAL NOTICES

**FIRST INSERTION**  
**FICTITIOUS NAME NOTICE**  
Notice is hereby given that AHAM CO, LLC, OWNER, desiring to engage in business under the fictitious name of MD MAESTRO located at 6900 TAVISTOCK LAKES BLVD, SUITE 400, ORLANDO, FLORIDA 32827 intends to register the said name in ORANGE county with the Division of Corporations, Florida Department of State, pursuant to section 865.09 of the Florida Statutes.  
September 9, 2021 21-03340W

**FIRST INSERTION**  
**FICTITIOUS NAME NOTICE**  
Notice is hereby given that AHAM CO, LLC, OWNER, desiring to engage in business under the fictitious name of TECHE SOLUTIONS located at 6900 TAVISTOCK LAKES BLVD, SUITE 400, ORLANDO, FLORIDA 32827 intends to register the said name in ORANGE county with the Division of Corporations, Florida Department of State, pursuant to section 865.09 of the Florida Statutes.  
September 9, 2021 21-03341W

**FIRST INSERTION**  
**FICTITIOUS NAME NOTICE**  
Notice is hereby given that CHERYL LYNNE BOYD, OWNER, desiring to engage in business under the fictitious name of FUREVER STRONG DOG TRAINING located at 326 CRABTREE AVE, ORLANDO, FLORIDA 32835 intends to register the said name in ORANGE county with the Division of Corporations, Florida Department of State, pursuant to section 865.09 of the Florida Statutes.  
September 9, 2021 21-03339W

**FIRST INSERTION**  
**FICTITIOUS NAME NOTICE**  
Notice is hereby given that JAMES J NIERODZINSKI, OWNER, desiring to engage in business under the fictitious name of JIM'S FULL LAWN SERVICE & HOME CLEAN OUT located at 3112 9TH ST, ORLANDO, FLORIDA 32833 intends to register the said name in ORANGE county with the Division of Corporations, Florida Department of State, pursuant to section 865.09 of the Florida Statutes.  
September 9, 2021 21-03338W

**FIRST INSERTION**  
**FICTITIOUS NAME NOTICE**  
Notice is hereby given that ONE TOUCH MOBILE LLC, OWNER, desiring to engage in business under the fictitious name of ONE TOUCH MOBILE LOCKSMITH located at 215 E MICHIGAN ST., ORLANDO, FLORIDA 32806 intends to register the said name in ORANGE county with the Division of Corporations, Florida Department of State, pursuant to section 865.09 of the Florida Statutes.  
September 9, 2021 21-03361W

**FIRST INSERTION**  
**NOTICE OF PUBLIC SALE**  
H & A Towing and Recovery LLC gives Notice of Foreclosure of Lien and intent to sell these vehicles on 09/24/2021, 11:00 am at 6548 E COLONIAL DR ORLANDO, FL 32807-5268, pursuant to subsection 713.78 of the Florida Statutes. H&A TOWING AND RECOVERY LLC reserves the right to accept or reject any and/or all bids.  
1N4AL3AP6FN902260  
2015 NISSAN ALTIMA  
September 9, 2021 21-03346W

**FIRST INSERTION**  
**NOTICE OF PUBLIC SALE**  
THE FOLLOWING VEHICLE WILL BE SOLD AT PUBLIC AUCTION ON SEPTEMBER 24, 2021, 9:00 AM, AT ADDRESS 815 S MILLS AVE, ORLANDO FL 32803, FREE OF ALL LIENS, PER FL. STAT. 713.785, AT LIENOR,S ADDRESS. NO TITLES, AS IS, CASH ONLY FOR  
2009 FORD  
VIN# 1FTPW14V29KB66708  
September 9, 2021 21-03329W

**FIRST INSERTION**  
**FICTITIOUS NAME NOTICE**  
Notice is hereby given that SARINA D EVANS, OWNER, desiring to engage in business under the fictitious name of FANTASTIC WEDDING FAVORS located at 6150 CLARCONA OCOEE RD, ORLANDO, FLORIDA 32810 intends to register the said name in ORANGE county with the Division of Corporations, Florida Department of State, pursuant to section 865.09 of the Florida Statutes.  
September 9, 2021 21-03359W

**FIRST INSERTION**  
**FICTITIOUS NAME NOTICE**  
Notice is hereby given that J P RESTAURANTS,LLC, JULIE PE-TRAKIS, OWNERS, desiring to engage in business under the fictitious name of CASK & LARDER located at 565 W. FAIRBANKS AVE, WINTER PARK, FLORIDA 32789 intends to register the said name in ORANGE county with the Division of Corporations, Florida Department of State, pursuant to section 865.09 of the Florida Statutes.  
September 9, 2021 21-03343W

**FIRST INSERTION**  
**NOTICE OF PUBLIC SALE**  
H & A Towing and Recovery LLC gives Notice of Foreclosure of Lien and intent to sell these vehicles on 09/24/2021, 11:00 am at 6548 E COLONIAL DR ORLANDO, FL 32807-5268, pursuant to subsection 713.78 of the Florida Statutes. H&A TOWING AND RECOVERY LLC reserves the right to accept or reject any and/or all bids.  
JHLRE38768C045467  
2008 HONDA CRV  
September 9, 2021 21-03347W

**FIRST INSERTION**  
**Notice Under Fictitious Name Law**  
According to Florida Statute Number 865.09  
**NOTICE IS HEREBY GIVEN** that the undersigned, desiring to engage in business under the Fictitious Name of Elsa Maria Marchany Vega located at 10160 andover point circle #1 in the City of orlando, Orange County, FL 32825 intends to register the said name with the Division of Corporations of the Department of State, Tallahassee, Florida.  
Dated this 1st day of September, 2021.  
Marchany-Garcia, Elsa M.  
September 9, 2021 21-03336W

**FIRST INSERTION**  
**Notice Under Fictitious Name Law**  
According to Florida Statute Number 865.09  
**NOTICE IS HEREBY GIVEN** that the undersigned, desiring to engage in business under the Fictitious Name of WORLD COLLECTABLES EXCHANGE located at 127 W. Fairbanks Ave. # 320 in the City of Winter Park, Orange County, FL 32789 intends to register the said name with the Division of Corporations of the Department of State, Tallahassee, Florida.  
Dated this 7th day of September, 2021.  
WORLD EQUITY LLC  
September 9, 2021 21-03358W

**FIRST INSERTION**  
**NOTICE OF PUBLIC SALE:**  
The Car Store of West Orange gives Notice of Foreclosure of Lien and intent to sell these vehicles on 09/24/2021, 7:00 am at 12811 W Colonial Dr Winter Garden, FL 34787-4119, pursuant to subsection 713.78 of the Florida Statutes. The Car Store of West Orange reserves the right to accept or reject any and/or all bids.  
00000101662 1971 GLASTRON  
WDBJF55FXVA427554  
1997 MERCEDES-BENZ  
JN8AR05SXVW1805584 1997 NISSAN  
WBADE6328VBW55468 1997 BMW  
1MEFM55S1A622805  
2001 MERCURY  
3VWSK69M13M117550  
2003 VOLKSWAGEN  
1N4AL11E63C103895 2003 NISSAN  
2T1BR32E94C289190 2004 TOYOTA  
1HGCM56314A142214 2004 HONDA  
1GHDX03E24D190574  
2004 OLDSMOBILE  
JTKKT624X50114817 2005 TOYOTA  
5UXFA135X5L09143 2005 BMW  
1HGCM56896A127622 2006 HONDA  
1GCEK19B56Z155125  
2006 CHEVROLET  
WBABW33527PV72683 2007 BMW  
1J4GB591X7L107027 2007 JEEP  
1FTPW14528FB91230 2008 FORD  
3GNFC16028G101313  
2008 CHEVROLET  
1FAHP35N18W191480 2008 FORD  
5GAEV23778J272662 2008 BUICK  
1N4AL21E48N540277 2008 NISSAN  
1N4AL2AP6AN417054 2010 NISSAN  
1N4AL2APOCC214546 2012 NISSAN  
1GCUYED3KZ183993  
2019 CHEVROLET  
7FYBE1624LD012758 2020 ANVL  
3AKJHHR9LSMJ0140  
2020 FREIGHTLINER  
September 9, 2021 21-03333W

**FIRST INSERTION**  
**Notice Under Fictitious Name Law**  
According to Florida Statute Number 865.09  
**NOTICE IS HEREBY GIVEN** that the undersigned, desiring to engage in business under the Fictitious Name of Florida Injuryline located at 37 North Orange Avenue, Suite 500 in the City of Orlando, Orange County, FL 32801 intends to register the said name with the Division of Corporations of the Department of State, Tallahassee, Florida.  
Dated this 3rd day of September, 2021.  
Joseph E. Ram Jr.  
September 9, 2021 21-03335W

**FIRST INSERTION**  
**FICTITIOUS NAME NOTICE**  
Notice is hereby given that JULIE PE-TRAKIS, J P RESTAURANTS,LLC, OWNERS, desiring to engage in business under the fictitious name of RAV-ENOUS PIG BREWING CO located at 511 WEST FAIRBANKS AVENUE, WINTER PARK, FLORIDA 32789 intends to register the said name in ORANGE county with the Division of Corporations, Florida Department of State, pursuant to section 865.09 of the Florida Statutes.  
September 9, 2021 21-03342W

**FIRST INSERTION**  
**FICTITIOUS NAME NOTICE**  
Notice is hereby given that VINCENT'S RESTAURANT INC, OWNER, desiring to engage in business under the fictitious name of VINCENT'S ITALIAN RESTAURANT located at 5914 NORTH ORANGE BLOSSOM TRAIL, MOUNT DORA, FLORIDA 32757 intends to register the said name in ORANGE county with the Division of Corporations, Florida Department of State, pursuant to section 865.09 of the Florida Statutes.  
September 9, 2021 21-03360W

**FIRST INSERTION**

**CITY OF OCOEE PUBLIC HEARING**

A Public Hearing before the Ocoee City Commission will be held **Tuesday, September 21, 2021, at 6:15 p.m.** or as soon thereafter as may be heard, in the Commission Chambers of City Hall at 150 North Lakeshore Drive, Ocoee, Florida, to consider the following:

**AN ORDINANCE OF THE CITY OF OCOEE, FLORIDA, RELATING TO ANIMALS; ENACTING SECTION 3 OF CHAPTER 43 OF THE CODE OF ORDINANCES OF THE CITY OF OCOEE; REGULATING THE RETAIL SALE OF DOGS, CATS AND RABBITS BY PET STORES; PROVIDING FOR SEVERABILITY; PROVIDING FOR CODIFICATION; PROVIDING AN EFFECTIVE DATE.**

City Hall is open to the public. The Ocoee City Commission may continue the public hearing to other dates and times, as it deems necessary. If a person decides to appeal any decision made by the City Commission with respect to any matter considered at such hearing, they will need a record of the proceedings, and for such purpose they may need to ensure that a verbatim record of the proceedings is made, which record includes the testimony and evidence upon which the appeal is to be based. In accordance with the Americans with Disabilities Act, persons needing a special accommodation or an interpreter to participate in this proceeding should contact the City Clerk's office at 407-905-3105 at least two days prior to the date of hearing.  
September 9, 2021 21-03327W

**FIRST INSERTION**

**CITY OF OCOEE NOTICE OF PUBLIC HEARING**

**TO CONSIDER THE RIGHT-OF-WAY VACATION OF NORTH LAKEWOOD AVENUE AND CLARCONA OCOEE ROAD PROJECT NO. VAC-21-031**

**NOTICE IS HEREBY GIVEN**, pursuant to Section 153-13, Article II of the Code of the City of Ocoee, that on **TUESDAY, SEPTEMBER 21, 2021, at 6:15 p.m.**, or as soon thereafter as practical, the **OCOEE CITY COMMISSION** will hold a **PUBLIC HEARING** at the Ocoee City Commission Chambers, 150 North Lakeshore Drive, Ocoee, Florida, to consider the vacation of the Right-of-Way for a portion of Lakewood Avenue & Clarcona Ocoee Road to consider the adoption of the following resolution:

**A RESOLUTION OF THE CITY OF OCOEE, FLORIDA, ABANDONING AND VACATING THAT PORTION OF NORTH LAKEWOOD AVENUE AND CLARCONA - OCOEE ROAD, AN 11,040 SF PORTION OF THE REMNANT RIGHT-OF-WAY LYING SOUTH OF CLARCONA OCOEE ROAD AND EAST OF NORTH LAKEWOOD AVENUE; PROVIDING FOR RECORDATION; PROVIDING FOR SEVERABILITY; PROVIDING AN EFFECTIVE DATE.**

Interested parties may appear at the public hearing and be heard with respect to the proposed actions. The complete case file, including a complete legal description by metes and bounds, may be inspected at the Ocoee Development Services Department, 150 North Lakeshore Drive, Ocoee, Florida, between the hours of 8:00 a.m. and 5:00 p.m., Monday through Friday, except legal holidays. The City Commission may continue the public hearing to other dates and times, as it deems necessary. Any interested party shall be advised that the dates, times, and places of any continuation of these or continued public hearings shall be announced during the hearings and that no further notices regarding these matters will be published. You are advised that any person who desires to appeal any decision made during the public hearings will need a record of the proceedings and for this purpose may need to ensure that a verbatim record of the proceedings is made which includes the testimony and evidence upon which the appeal is based. Persons with disabilities needing assistance to participate in any of the proceedings should contact the City Clerk's Office 48 hours in advance of the meeting at (407) 905-3105.  
September 9, 2021 21-03344W

**FIRST INSERTION**  
**NOTICE OF PUBLIC SALE**  
Pursuant to F.S. 713.78, Airport Towing Service will sell the following vehicles and/or vessels. Seller reserves the right to bid. Sold as is, no warranty. Seller guarantees no title, terms cash. Seller reserves the right to refuse any or all bids.  
**SALE DATE 09/20/2021, 11:00 AM**  
**Located at 6690 E. Colonial Drive, Orlando FL 32807**  
2003 VOLKSWAGEN  
3VWSK69M83M096020  
2005 DODGE  
1D4HD48K25F570318  
2003 FORD  
1FAPP55223A202341  
2010 FORD  
1FAHP3FN6AW126029  
2010 VOLKSWAGEN  
WVWFV7AJ7AW368797  
2001 DODGE  
3B7HC13Y71M274988  
2005 NISSAN  
1N4AL11D55C134467  
1991 CHEVROLET  
1GCCS14R8M8204204  
**Located at: 4507 E. Wetherbee Rd, Orlando, FL 32824**  
2000 TOYOTA  
4T1BG22K0YU010459

2011 DODGE  
1B3BD1FG5BN513159  
**SALE DATE 09/21/2021, 11:00 AM**  
**Located at 6690 E. Colonial Drive, Orlando FL 32807**  
1997 FORD  
1FALP45XXVF179485  
**SALE DATE 09/23/2021, 11:00 AM**  
**Located at 6690 E. Colonial Drive, Orlando FL 32807**  
2007 TOYOTA  
2T1BR32E77C742405  
**SALE DATE 09/24/2021, 11:00 AM**  
**Located at 6690 E. Colonial Drive, Orlando FL 32807**  
2015 JEEP  
ZACCJBC19FPB86863  
2006 CHEVROLET  
1G1AL58F267821093  
**Located at: 4507 E. Wetherbee Rd, Orlando, FL 32824**  
2011 FORD  
3FAHP0HA2BR152365  
September 9, 2021 21-03328W

**FIRST INSERTION**

**NOTICE OF PUBLIC HEARING CITY OF WINTER GARDEN, FLORIDA**

Pursuant to the Florida Statutes, notice is hereby given that the City of Winter Garden City Commission will, on September 29, 2021 at 6:30 p.m. or as soon after as possible, hold a public hearing in the City Commission Chambers located at 300 West Plant Street, Winter Garden, Florida in order to consider the adoption of the following ordinance(s):

**ORDINANCE 21-19**

**AN ORDINANCE OF THE CITY OF WINTER GARDEN, FLORIDA AMENDING THE FUTURE LAND USE MAP OF THE WINTER GARDEN COMPREHENSIVE PLAN BY CHANGING THE LAND USE DESIGNATION OF REAL PROPERTY GENERALLY DESCRIBED AS APPROXIMATELY 0.28 +/- ACRES LOCATED AT 35 AND 41 WEST MORGAN STREET, WEST OF CROSS STREET, EAST OF VINELAND ROAD, NORTH OF WEST MORGAN STREET, AND SOUTH OF BROAD STREET FROM LOW DENSITY RESIDENTIAL TO COMMERCIAL; PROVIDING FOR SEVERABILITY; PROVIDING FOR AN EFFECTIVE DATE.**

**ORDINANCE 21-20**

**AN ORDINANCE OF THE CITY OF WINTER GARDEN, FLORIDA, REZONING CERTAIN REAL PROPERTY GENERALLY DESCRIBED AS APPROXIMATELY 1.11 +/- ACRES OF LAND GENERALLY LOCATED AT 35 & 41 WEST MORGAN STREET & 965, 981, 995 VINELAND ROAD, ON THE NORTHEAST CORNER OF VINELAND ROAD AND WEST MORGAN STREET; FROM C-2 (ARTERIAL COMMERCIAL DISTRICT) AND R-2 (RESIDENTIAL DISTRICT), TO PCD (PLANNED COMMERCIAL DEVELOPMENT) AS SET FORTH IN THIS ORDINANCE; PROVIDING FOR CERTAIN PCD REQUIREMENTS AND DESCRIBING THE DEVELOPMENT AS THE MORGAN STREET OFFICE RETAIL COMPLEX; AND PROVIDING FOR SEVERABILITY, CONFLICTS AND AN EFFECTIVE DATE.**

Copies of the proposed ordinance(s) (which includes the legal description in metes and bounds of the proposed site) may be inspected by the public between the hours of 8:00 a.m. and 5:00 p.m. Monday through Friday of each week, except for legal holidays, at the Planning & Zoning Division in City Hall, 300 West Plant Street, Winter Garden, Florida. For more information, please call Kelly Carson at 656-4111 ext. 2312.

Interested parties may appear at the meetings and be heard with respect to the proposed ordinance(s). Written comments will be accepted before or at the public hearings. Persons wishing to appeal any decision made by the Planning and Zoning Board at such hearing will need a record of the proceedings and for such purpose you may need to ensure that a verbatim record of the proceedings is made, which includes the testimony and evidence upon which the appeal is based. The City does not provide this verbatim record. Persons with disabilities needing special accommodations to participate in this public hearing should contact the City Clerk's Office at (407) 656-4111 at least 48 hours prior to the meeting. Monday through Friday of each week, except for legal holidays, at the Planning & Zoning Division in City Hall, 300 West Plant Street, Winter Garden, Florida.

**LOCATION MAP**

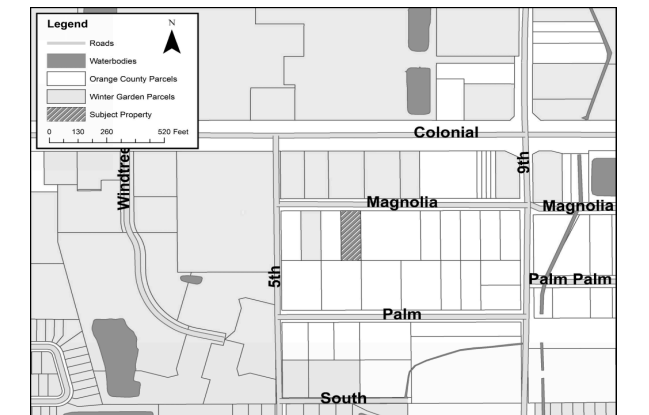

September 9, 2021

21-03357W

**HOW TO PUBLISH YOUR LEGAL NOTICE**  
IN THE BUSINESS OBSERVER

**CALL 941-906-9386**  
and select the appropriate County name from the menu option  
or e-mail [legal@businessobserverfl.com](mailto:legal@businessobserverfl.com)

**Business Observer**

**OFFICIAL COURTHOUSE WEBSITES:**

MANATEE COUNTY: [manateeclerk.com](http://manateeclerk.com) | SARASOTA COUNTY: [sarasotaclerk.com](http://sarasotaclerk.com) | CHARLOTTE COUNTY: [charlotte.realforeclose.com](http://charlotte.realforeclose.com)  
LEE COUNTY: [leeclerk.org](http://leeclerk.org) | COLLIER COUNTY: [collierclerk.com](http://collierclerk.com) | HILLSBOROUGH COUNTY: [hillsclerk.com](http://hillsclerk.com)  
PASCO COUNTY: [pasco.realforeclose.com](http://pasco.realforeclose.com) | PINELLAS COUNTY: [pinellasclerk.org](http://pinellasclerk.org)  
POLK COUNTY: [polkcountyclerk.net](http://polkcountyclerk.net) | ORANGE COUNTY: [myorangeclerk.com](http://myorangeclerk.com)

Check out your notices on:  
[www.floridapublicnotices.com](http://www.floridapublicnotices.com)

**Business Observer**







**ORANGE COUNTY**

FIRST INSERTION
<p>NOTICE OF APPLICATION FOR TAX DEED</p> <p>NOTICE IS HEREBY GIVEN that MUNICIPAL POINT CAPITAL LP the holder of the following certificate has filed said certificate for a TAX DEED to be issued thereon. The Certificate number and year of issuance, the description of the property, and the names in which it was assessed are as follows:</p> <p>CERTIFICATE NUMBER: 2019-14498</p> <p>YEAR OF ISSUANCE: 2019</p> <p>DESCRIPTION OF PROPERTY: VILLANOVA AT HUNTERS CREEK CONDOMINIUM 8103/2271 UNIT 101 BLDG 3</p> <p>PARCEL ID # 29-24-29-8824-03-101</p> <p>Name in which assessed: A AND A STRATEGY ALLIANCE INC</p> <p>ALL of said property being in the County of Orange, State of Florida. Unless such certificate shall be redeemed according to law, the property described in such certificate will be sold to the highest bidder online at www.orange.realtaxdeed.com scheduled to begin at 10:00 a.m. ET, Oct 21, 2021.</p> <p>Dated: Sep 02, 2021 Phil Diamond County Comptroller Orange County, Florida By: M Hildebrandt Deputy Comptroller September 9, 16, 23, 30, 2021 21-03283W</p>

FIRST INSERTION
<p>NOTICE OF APPLICATION FOR TAX DEED</p> <p>NOTICE IS HEREBY GIVEN that MERIDIAN TAX the holder of the following certificate has filed said certificate for a TAX DEED to be issued thereon. The Certificate number and year of issuance, the description of the property, and the names in which it was assessed are as follows:</p> <p>CERTIFICATE NUMBER: 2019-14730</p> <p>YEAR OF ISSUANCE: 2019</p> <p>DESCRIPTION OF PROPERTY: DOMMERICH HILLS FOURTH ADDITION 1/2 LOT 1 BLK A</p> <p>PARCEL ID # 29-21-30-9572-01-010</p> <p>Name in which assessed: PENSICO TRUST COMPANY LLC CUSTODIAN</p> <p>ALL of said property being in the County of Orange, State of Florida. Unless such certificate shall be redeemed according to law, the property described in such certificate will be sold to the highest bidder online at www.orange.realtaxdeed.com scheduled to begin at 10:00 a.m. ET, Oct 21, 2021.</p> <p>Dated: Sep 02, 2021 Phil Diamond County Comptroller Orange County, Florida By: M Hildebrandt Deputy Comptroller September 9, 16, 23, 30, 2021 21-03284W</p>

FIRST INSERTION
<p>NOTICE OF APPLICATION FOR TAX DEED</p> <p>NOTICE IS HEREBY GIVEN that MERIDIAN TAX the holder of the following certificate has filed said certificate for a TAX DEED to be issued thereon. The Certificate number and year of issuance, the description of the property, and the names in which it was assessed are as follows:</p> <p>CERTIFICATE NUMBER: 2019-14977</p> <p>YEAR OF ISSUANCE: 2019</p> <p>DESCRIPTION OF PROPERTY: TOWN OF WINTER PARK A/67 &amp; B/86 &amp; MISC BOOK 3/220 LOT 1 BLK 42</p> <p>PARCEL ID # 05-22-30-9400-42-010</p> <p>Name in which assessed: LAKE HALL LODGE NO 33 F AM</p> <p>ALL of said property being in the County of Orange, State of Florida. Unless such certificate shall be redeemed according to law, the property described in such certificate will be sold to the highest bidder online at www.orange.realtaxdeed.com scheduled to begin at 10:00 a.m. ET, Oct 21, 2021.</p> <p>Dated: Sep 02, 2021 Phil Diamond County Comptroller Orange County, Florida By: M Hildebrandt Deputy Comptroller September 9, 16, 23, 30, 2021 21-03285W</p>

FIRST INSERTION
<p>NOTICE OF APPLICATION FOR TAX DEED</p> <p>NOTICE IS HEREBY GIVEN that MERIDIAN TAX the holder of the following certificate has filed said certificate for a TAX DEED to be issued thereon. The Certificate number and year of issuance, the description of the property, and the names in which it was assessed are as follows:</p> <p>CERTIFICATE NUMBER: 2019-15047</p> <p>YEAR OF ISSUANCE: 2019</p> <p>DESCRIPTION OF PROPERTY: MAGNOLIA GARDENS SUB R/85 LOT 5 BLK B</p> <p>PARCEL ID # 06-22-30-5436-02-050</p> <p>Name in which assessed: STAB CAB LLC</p> <p>ALL of said property being in the County of Orange, State of Florida. Unless such certificate shall be redeemed according to law, the property described in such certificate will be sold to the highest bidder online at www.orange.realtaxdeed.com scheduled to begin at 10:00 a.m. ET, Oct 21, 2021.</p> <p>Dated: Sep 02, 2021 Phil Diamond County Comptroller Orange County, Florida By: M Hildebrandt Deputy Comptroller September 9, 16, 23, 30, 2021 21-03286W</p>

FIRST INSERTION
<p>NOTICE OF APPLICATION FOR TAX DEED</p> <p>NOTICE IS HEREBY GIVEN that MERIDIAN TAX the holder of the following certificate has filed said certificate for a TAX DEED to be issued thereon. The Certificate number and year of issuance, the description of the property, and the names in which it was assessed are as follows:</p> <p>CERTIFICATE NUMBER: 2019-15383</p> <p>YEAR OF ISSUANCE: 2019</p> <p>DESCRIPTION OF PROPERTY: ARCADIA ACRES SECTION ONE X/96 LOT 21 (LESS WLY 43.32 FT) &amp; WLY 54.15 FT OF LOT 22 BLK H</p> <p>PARCEL ID # 14-22-30-0226-08-220</p> <p>Name in which assessed: 7901 DELPHIA TRUST</p> <p>ALL of said property being in the County of Orange, State of Florida. Unless such certificate shall be redeemed according to law, the property described in such certificate will be sold to the highest bidder online at www.orange.realtaxdeed.com scheduled to begin at 10:00 a.m. ET, Oct 21, 2021.</p> <p>Dated: Sep 02, 2021 Phil Diamond County Comptroller Orange County, Florida By: M Hildebrandt Deputy Comptroller September 9, 16, 23, 30, 2021 21-03287W</p>

FIRST INSERTION
<p>NOTICE OF APPLICATION FOR TAX DEED</p> <p>NOTICE IS HEREBY GIVEN that MUNICIPAL POINT CAPITAL LP the holder of the following certificate has filed said certificate for a TAX DEED to be issued thereon. The Certificate number and year of issuance, the description of the property, and the names in which it was assessed are as follows:</p> <p>CERTIFICATE NUMBER: 2019-17268</p> <p>YEAR OF ISSUANCE: 2019</p> <p>DESCRIPTION OF PROPERTY: VENETIAN PLACE CONDOMINIUM 8755/1712 UNIT 1117 BLDG 11</p> <p>PARCEL ID # 10-23-30-8908-01-117</p> <p>Name in which assessed: REALITY RED LLC</p> <p>ALL of said property being in the County of Orange, State of Florida. Unless such certificate shall be redeemed according to law, the property described in such certificate will be sold to the highest bidder online at www.orange.realtaxdeed.com scheduled to begin at 10:00 a.m. ET, Oct 21, 2021.</p> <p>Dated: Sep 02, 2021 Phil Diamond County Comptroller Orange County, Florida By: M Hildebrandt Deputy Comptroller September 9, 16, 23, 30, 2021 21-03288W</p>

FIRST INSERTION
<p>NOTICE OF APPLICATION FOR TAX DEED</p> <p>NOTICE IS HEREBY GIVEN that MUNICIPAL POINT CAPITAL LP the holder of the following certificate has filed said certificate for a TAX DEED to be issued thereon. The Certificate number and year of issuance, the description of the property, and the names in which it was assessed are as follows:</p> <p>CERTIFICATE NUMBER: 2019-17278</p> <p>YEAR OF ISSUANCE: 2019</p> <p>DESCRIPTION OF PROPERTY: VENETIAN PLACE CONDOMINIUM 8755/1712 UNIT 1614 BLDG 16</p> <p>PARCEL ID # 10-23-30-8908-01-614</p> <p>Name in which assessed: SAMUEL NWANOSIKE</p> <p>ALL of said property being in the County of Orange, State of Florida. Unless such certificate shall be redeemed according to law, the property described in such certificate will be sold to the highest bidder online at www.orange.realtaxdeed.com scheduled to begin at 10:00 a.m. ET, Oct 21, 2021.</p> <p>Dated: Sep 02, 2021 Phil Diamond County Comptroller Orange County, Florida By: M Hildebrandt Deputy Comptroller September 9, 16, 23, 30, 2021 21-03289W</p>

FIRST INSERTION
<p>NOTICE OF APPLICATION FOR TAX DEED</p> <p>NOTICE IS HEREBY GIVEN that MERIDIAN TAX the holder of the following certificate has filed said certificate for a TAX DEED to be issued thereon. The Certificate number and year of issuance, the description of the property, and the names in which it was assessed are as follows:</p> <p>CERTIFICATE NUMBER: 2019-17861</p> <p>YEAR OF ISSUANCE: 2019</p> <p>DESCRIPTION OF PROPERTY: CENTRAL PARK ON LEE VISTA CONDOMINIUM 8316/2619 UNIT 1702</p> <p>PARCEL ID # 24-23-30-1256-01-702</p> <p>Name in which assessed: LIZEIDA J GONZALEZ, ABEL RAMOS</p> <p>ALL of said property being in the County of Orange, State of Florida. Unless such certificate shall be redeemed according to law, the property described in such certificate will be sold to the highest bidder online at www.orange.realtaxdeed.com scheduled to begin at 10:00 a.m. ET, Oct 21, 2021.</p> <p>Dated: Sep 02, 2021 Phil Diamond County Comptroller Orange County, Florida By: M Hildebrandt Deputy Comptroller September 9, 16, 23, 30, 2021 21-03290W</p>

FIRST INSERTION
<p>NOTICE OF APPLICATION FOR TAX DEED</p> <p>NOTICE IS HEREBY GIVEN that MUNICIPAL POINT CAPITAL LP the holder of the following certificate has filed said certificate for a TAX DEED to be issued thereon. The Certificate number and year of issuance, the description of the property, and the names in which it was assessed are as follows:</p> <p>CERTIFICATE NUMBER: 2019-17883</p> <p>YEAR OF ISSUANCE: 2019</p> <p>DESCRIPTION OF PROPERTY: VISTA LAKES - TOWN CENTER SOUTH 56/30 LOT 1</p> <p>PARCEL ID # 24-23-30-8969-00-010</p> <p>Name in which assessed: ANIMAL HOSPITAL AT VISTA LAKES LLC</p> <p>ALL of said property being in the County of Orange, State of Florida. Unless such certificate shall be redeemed according to law, the property described in such certificate will be sold to the highest bidder online at www.orange.realtaxdeed.com scheduled to begin at 10:00 a.m. ET, Oct 21, 2021.</p> <p>Dated: Sep 02, 2021 Phil Diamond County Comptroller Orange County, Florida By: M Hildebrandt Deputy Comptroller September 9, 16, 23, 30, 2021 21-03291W</p>

FIRST INSERTION
<p>NOTICE OF APPLICATION FOR TAX DEED</p> <p>NOTICE IS HEREBY GIVEN that MUNICIPAL POINT CAPITAL LP the holder of the following certificate has filed said certificate for a TAX DEED to be issued thereon. The Certificate number and year of issuance, the description of the property, and the names in which it was assessed are as follows:</p> <p>CERTIFICATE NUMBER: 2019-18274</p> <p>YEAR OF ISSUANCE: 2019</p> <p>DESCRIPTION OF PROPERTY: SUNCREST UNIT 2 19/70 LOT 116</p> <p>PARCEL ID # 05-22-31-8413-01-160</p> <p>Name in which assessed: STEVEN MOFFETT</p> <p>ALL of said property being in the County of Orange, State of Florida. Unless such certificate shall be redeemed according to law, the property described in such certificate will be sold to the highest bidder online at www.orange.realtaxdeed.com scheduled to begin at 10:00 a.m. ET, Oct 21, 2021.</p> <p>Dated: Sep 02, 2021 Phil Diamond County Comptroller Orange County, Florida By: M Hildebrandt Deputy Comptroller September 9, 16, 23, 30, 2021 21-03292W</p>

FIRST INSERTION
<p>NOTICE OF APPLICATION FOR TAX DEED</p> <p>NOTICE IS HEREBY GIVEN that MERIDIAN TAX the holder of the following certificate has filed said certificate for a TAX DEED to be issued thereon. The Certificate number and year of issuance, the description of the property, and the names in which it was assessed are as follows:</p> <p>CERTIFICATE NUMBER: 2019-18802</p> <p>YEAR OF ISSUANCE: 2019</p> <p>DESCRIPTION OF PROPERTY: BUNKER HILL K/40 LOT 4 BLK D</p> <p>PARCEL ID # 24-22-31-1052-04-040</p> <p>Name in which assessed: DOUGLAS PAT BURDETTE</p> <p>ALL of said property being in the County of Orange, State of Florida. Unless such certificate shall be redeemed according to law, the property described in such certificate will be sold to the highest bidder online at www.orange.realtaxdeed.com scheduled to begin at 10:00 a.m. ET, Oct 21, 2021.</p> <p>Dated: Sep 02, 2021 Phil Diamond County Comptroller Orange County, Florida By: M Hildebrandt Deputy Comptroller September 9, 16, 23, 30, 2021 21-03293W</p>

FIRST INSERTION
<p>NOTICE OF APPLICATION FOR TAX DEED</p> <p>NOTICE IS HEREBY GIVEN that MUNICIPAL POINT CAPITAL LP the holder of the following certificate has filed said certificate for a TAX DEED to be issued thereon. The Certificate number and year of issuance, the description of the property, and the names in which it was assessed are as follows:</p> <p>CERTIFICATE NUMBER: 2019-19090</p> <p>YEAR OF ISSUANCE: 2019</p> <p>DESCRIPTION OF PROPERTY: STONEYBROOK UNIT 2 40/106 LOT 16 BLK 14</p> <p>PARCEL ID # 01-23-31-1982-14-016</p> <p>Name in which assessed: PAUL ZILKHA</p> <p>ALL of said property being in the County of Orange, State of Florida. Unless such certificate shall be redeemed according to law, the property described in such certificate will be sold to the highest bidder online at www.orange.realtaxdeed.com scheduled to begin at 10:00 a.m. ET, Oct 21, 2021.</p> <p>Dated: Sep 02, 2021 Phil Diamond County Comptroller Orange County, Florida By: M Hildebrandt Deputy Comptroller September 9, 16, 23, 30, 2021 21-03294W</p>

FIRST INSERTION
<p>NOTICE OF APPLICATION FOR TAX DEED</p> <p>NOTICE IS HEREBY GIVEN that MERIDIAN TAX the holder of the following certificate has filed said certificate for a TAX DEED to be issued thereon. The Certificate number and year of issuance, the description of the property, and the names in which it was assessed are as follows:</p> <p>CERTIFICATE NUMBER: 2019-19228</p> <p>YEAR OF ISSUANCE: 2019</p> <p>DESCRIPTION OF PROPERTY: CROWNTREE LAKES TRACTS 2 &amp; 3 57/130 LOT 191</p> <p>PARCEL ID # 18-23-31-1776-01-910</p> <p>Name in which assessed: REYGO LLC</p> <p>ALL of said property being in the County of Orange, State of Florida. Unless such certificate shall be redeemed according to law, the property described in such certificate will be sold to the highest bidder online at www.orange.realtaxdeed.com scheduled to begin at 10:00 a.m. ET, Oct 21, 2021.</p> <p>Dated: Sep 02, 2021 Phil Diamond County Comptroller Orange County, Florida By: M Hildebrandt Deputy Comptroller September 9, 16, 23, 30, 2021 21-03295W</p>

FIRST INSERTION
<p>NOTICE OF APPLICATION FOR TAX DEED</p> <p>NOTICE IS HEREBY GIVEN that MUNICIPAL POINT CAPITAL LP the holder of the following certificate has filed said certificate for a TAX DEED to be issued thereon. The Certificate number and year of issuance, the description of the property, and the names in which it was assessed are as follows:</p> <p>CERTIFICATE NUMBER: 2019-19381</p> <p>YEAR OF ISSUANCE: 2019</p> <p>DESCRIPTION OF PROPERTY: TRAILS AT MOSS PARK 93/21 LOT 63</p> <p>PARCEL ID # 10-24-31-9015-00-630</p> <p>Name in which assessed: NEW DIRECTION IRA INC FBO MELBA VIT'AL IRA</p> <p>ALL of said property being in the County of Orange, State of Florida. Unless such certificate shall be redeemed according to law, the property described in such certificate will be sold to the highest bidder online at www.orange.realtaxdeed.com scheduled to begin at 10:00 a.m. ET, Oct 21, 2021.</p> <p>Dated: Sep 02, 2021 Phil Diamond County Comptroller Orange County, Florida By: M Hildebrandt Deputy Comptroller September 9, 16, 23, 30, 2021 21-03296W</p>

FIRST INSERTION
<p>NOTICE OF APPLICATION FOR TAX DEED</p> <p>NOTICE IS HEREBY GIVEN that MERIDIAN TAX the holder of the following certificate has filed said certificate for a TAX DEED to be issued thereon. The Certificate number and year of issuance, the description of the property, and the names in which it was assessed are as follows:</p> <p>CERTIFICATE NUMBER: 2019-20261</p> <p>YEAR OF ISSUANCE: 2019</p> <p>DESCRIPTION OF PROPERTY: AVALON LAKES PHASE 3 VILLAGES A &amp; B 58/81 LOT 141 VILLAGE B</p> <p>PARCEL ID # 31-22-32-0534-02-141</p> <p>Name in which assessed: AMMAR ABU JUBARA, AMANI ABU JUBARA</p> <p>ALL of said property being in the County of Orange, State of Florida. Unless such certificate shall be redeemed according to law, the property described in such certificate will be sold to the highest bidder online at www.orange.realtaxdeed.com scheduled to begin at 10:00 a.m. ET, Oct 21, 2021.</p> <p>Dated: Sep 02, 2021 Phil Diamond County Comptroller Orange County, Florida By: M Hildebrandt Deputy Comptroller September 9, 16, 23, 30, 2021 21-03297W</p>

FIRST INSERTION
<p>NOTICE OF APPLICATION FOR TAX DEED</p> <p>NOTICE IS HEREBY GIVEN that GERAN-Z LLC the holder of the following certificate has filed said certificate for a TAX DEED to be issued thereon. The Certificate number and year of issuance, the description of the property, and the names in which it was assessed are as follows:</p> <p>CERTIFICATE NUMBER: 2019-20347</p> <p>YEAR OF ISSUANCE: 2019</p> <p>DESCRIPTION OF PROPERTY: ROCKET CITY UNIT 2 Z/56 A/K/A CAPE ORLANDO ESTATES UNIT 2 1855/292 BEG AT NE COR LOT 15 BLK 41 RUN W 125 FT S 36 FT E 81.69 FT N 44 DEG E 22 FT NELY 30.83 FT N 8.95 FT TO POB</p> <p>PARCEL ID # 01-23-32-7599-41-152</p> <p>Name in which assessed: BUENAVENTURA MARELLA, FELICITAS MARELLA</p> <p>ALL of said property being in the County of Orange, State of Florida. Unless such certificate shall be redeemed according to law, the property described in such certificate will be sold to the highest bidder online at www.orange.realtaxdeed.com scheduled to begin at 10:00 a.m. ET, Oct 21, 2021.</p> <p>Dated: Sep 02, 2021 Phil Diamond County Comptroller Orange County, Florida By: M Hildebrandt Deputy Comptroller September 9, 16, 23, 30, 2021 21-03298W</p>

FIRST INSERTION
<p>NOTICE OF APPLICATION FOR TAX DEED</p> <p>NOTICE IS HEREBY GIVEN that MERIDIAN TAX the holder of the following certificate has filed said certificate for a TAX DEED to be issued thereon. The Certificate number and year of issuance, the description of the property, and the names in which it was assessed are as follows:</p> <p>CERTIFICATE NUMBER: 2019-20475</p> <p>YEAR OF ISSUANCE: 2019</p> <p>DESCRIPTION OF PROPERTY: CAPE ORLANDO ESTATES UNIT 12A 4/66 LOT 7 BLK 2</p> <p>PARCEL ID # 10-23-32-1184-02-070</p> <p>Name in which assessed: JAMES H WARE 1/2 INT, JERRY L WARE 1/2 INT</p> <p>ALL of said property being in the County of Orange, State of Florida. Unless such certificate shall be redeemed according to law, the property described in such certificate will be sold to the highest bidder online at www.orange.realtaxdeed.com scheduled to begin at 10:00 a.m. ET, Oct 21, 2021.</p> <p>Dated: Sep 02, 2021 Phil Diamond County Comptroller Orange County, Florida By: M Hildebrandt Deputy Comptroller September 9, 16, 23, 30, 2021 21-03299W</p>

FIRST INSERTION
<p>NOTICE OF APPLICATION FOR TAX DEED</p> <p>NOTICE IS HEREBY GIVEN that MERIDIAN TAX the holder of the following certificate has filed said certificate for a TAX DEED to be issued thereon. The Certificate number and year of issuance, the description of the property, and the names in which it was assessed are as follows:</p> <p>CERTIFICATE NUMBER: 2019-20498</p> <p>YEAR OF ISSUANCE: 2019</p> <p>DESCRIPTION OF PROPERTY: CAPE ORLANDO ESTATES UNIT 12A 4/66 LOT 11 BLK 16</p> <p>PARCEL ID # 10-23-32-1184-16-110</p> <p>Name in which assessed: EDWARD Y ACOSTA</p> <p>ALL of said property being in the County of Orange, State of Florida. Unless such certificate shall be redeemed according to law, the property described in such certificate will be sold to the highest bidder online at www.orange.realtaxdeed.com scheduled to begin at 10:00 a.m. ET, Oct 21, 2021.</p> <p>Dated: Sep 02, 2021 Phil Diamond County Comptroller Orange County, Florida By: M Hildebrandt Deputy Comptroller September 9, 16, 23, 30, 2021 21-03300W</p>











# ORANGE COUNTY

## FIRST INSERTION

May 13, 2021

### NOTICE OF DEFAULT AND INTENT TO FORECLOSE

Jerry E. Aron, P.A. has been appointed as Trustee by Holiday Inn Club Vacations Incorporated for the purposes of instituting a Trustee Foreclosure and Sale under Florida Statutes 721.856. The obligors listed below are hereby notified that you are in default on your account by failing to make the required payments pursuant to your Promissory Note. Your failure to make timely payments resulted in you defaulting on the Note/Mortgage.

**TIMESHARE PLAN: ORANGE LAKE COUNTRY CLUB**  
 VILLA I, together with an undivided interest in the common elements appurtenant thereto, according to the Declaration of Condominium thereof recorded in OR Book 3300, Page 2702 in the Public Records of Orange County, Florida.  
 VILLA II, together with an undivided interest in the common elements appurtenant thereto, according to the Declaration of Condominium thereof recorded in OR Book 4846, Page 1619 in the Public Records of Orange County, Florida.  
 VILLA III, together with an undivided interest in the common elements appurtenant thereto, according to the Declaration of Condominium thereof recorded in OR Book 5914, Page 1965 in the Public Records of Orange County, Florida.  
 Contract Number: 6242535 -- JANET SUE ALEXANDER and ROBERT TRUMAN ALEXANDER, II, ("Owner(s)"), 2229 SKEETERTOWN RD, SUFFOLK, VA 23434, Villa I/Week 49 in Unit No. 004027/Principal Balance: \$13,676.43 / Mtg Doc #20150525942  
 Contract Number: 6481245 -- NICOTRA CATRICE ANDERSON, ("Owner(s)"), 616 MONROE ST, MARKED TREE, AR 72365, Villa I/Week 43 in Unit No. 005262/Principal Balance: \$9,963.37 / Mtg Doc #20180083472  
 Contract Number: 6478428 -- MARIE CLAIRE BOURGEOU and LOUISE ALEXANDRE, ("Owner(s)"), 351 SUMMIT DR, ORANGE PARK, FL 32073, Villa I/Week 44 in Unit No. 003228/Principal Balance: \$17,749.17

Mtg Doc #20160471217  
 Contract Number: 6551965 -- EVAN PAUL BRATFISH-PARDUE, ("Owner(s)"), 50571 JEFFERSON AVE APT 11, NEW BALTIMORE, MI 48047, Villa II/Week 20 in Unit No. 002519/Principal Balance: \$23,271.31 / Mtg Doc #20180344899  
 Contract Number: 6544127 -- BRADFORD JENNINGS BROWN, ("Owner(s)"), 548 CRAIG KROPPF DR, WELLSFORD, SC 29385, Villa I/Week 47 in Unit No. 005280/Principal Balance: \$11,656.96 / Mtg Doc #20180406859  
 Contract Number: 6393528 -- CHRISTINE M. COLEMAN and ARTHUR LEE COLEMAN, ("Owner(s)"), 495 CREEKVIEW BLVD, COVINGTON, GA 30016, Villa III/Week 49 EVEN in Unit No. 086616/Principal Balance: \$11,177.70 / Mtg Doc #20170121385  
 Contract Number: 6539948 -- WELDON EVERETT DEAN and JOYCE COOK DEAN, ("Owner(s)"), 2265 S FM 1138, ROYSE CITY, TX 75189 and PO BOX 10, LAVON, TX 75166, Villa I/Week 25 in Unit No. 004020/Principal Balance: \$39,562.39 / Mtg Doc #20180386867  
 Contract Number: 6343429 -- SONYA R. EASLEY A/K/A MS SONYA R. EASLEY, ("Owner(s)"), 4849 W FULTON ST APT 2, CHICAGO, IL 60644, Villa III/Week 21 in Unit No. 003433/Principal Balance: \$17,676.22 / Mtg Doc #20160389739  
 Contract Number: 6190065 -- WILLIE E. ELLINGTON and LIDIA T. ELLINGTON, ("Owner(s)"), 24 BRASS LANTERN WAY, WATERBURY, CT 06708 and 1850 LAFAYETTE AVE APT 16H, BRONX, NY 10473, Villa I/Week 18 in Unit No. 003022/Principal Balance: \$7,233.18 / Mtg Doc #20150425740  
 Contract Number: 6256297 -- STEPHEN ALLEN FAITH and GLENDA ANNETTE FAITH, and FLOY GAY LOOPER ("Owner(s)"), 3203 E 11TH PL, BIG SPRING, TX 79720 and 1600 S LANCASTER ST UNIT 3, BIG SPRING, TX 79720, Villa I/Week 47 in Unit No. 000441/Principal Balance: \$16,431.51 / Mtg Doc #20160565438  
 Contract Number: 6354802 -- LORRAINE P. GAILLARD, ("Owner(s)"), 279 RICHMOND FARM CIR, LEXINGTON, SC 29072, Villa I/Week 51 in Unit No. 000447/Principal Balance: \$23,561.40 / Mtg Doc #20160403478  
 Contract Number: 6528519 -- HEATHER DONNE GREEN, ("Owner(s)"),

1660 SANDRIDGE RD, DORCHESTER, SC 29437, Villa I/Week 44 in Unit No. 005215/Principal Balance: \$9,220.79 / Mtg Doc #20180356801  
 Contract Number: 6539528 -- KIMBERLY KAYE JACKSON and TOMMY JONES, ("Owner(s)"), 4456 LONE ALCOVE DR, SPRING, TX 77386, Villa II/Week 37 in Unit No. 002571/Principal Balance: \$16,764.49 / Mtg Doc #20170657036  
 Contract Number: 6352833 -- MARIO JAUREGUI, ("Owner(s)"), 2003 W HURON ST APT 1, CHICAGO, IL 60612, Villa I/Week 1 in Unit No. 004262/Principal Balance: \$14,944.37 / Mtg Doc #20170135317  
 Contract Number: 6499250 -- LARRY GAYLE JUNGSMANN, ("Owner(s)"), 806 W 22ND ST, CAMERON, TX 76520, Villa III/Week 19 ODD in Unit No. 087522/Principal Balance: \$14,394.49 / Mtg Doc #20170132055  
 Contract Number: 6353126 -- WALTER C. LEE, ("Owner(s)"), 4067 N 7TH ST, MILWAUKEE, WI 53209, Villa III/Week 48 in Unit No. 003425/Principal Balance: \$12,983.52 / Mtg Doc #20180041987  
 Contract Number: 6554693 -- MATTHEW MICHAEL MITTS, ("Owner(s)"), 2 SUNNY TRAIL CT, ELLISVILLE, MO 63011, Villa III/Week 14 in Unit No. 087827/Principal Balance: \$27,979.25 / Mtg Doc #20180341581  
 Contract Number: 6462622 -- TIMOTHY RAYMOND MONDE and KIMBERLY ANN MONDE, ("Owner(s)"), 4807 ASHERTON PL NW, CONCORD, NC 28027, Villa I/Week 18 in Unit No. 003061/Principal Balance: \$15,858.97 / Mtg Doc #20170021189  
 Contract Number: 6463844 -- MONICA ORTIZ RIVERA and RAMON NATAL ADAMES, ("Owner(s)"), 1409 GULF STREAM CIR APT 203, BRANDON, FL 33511 and 4705 FOXSHIRE CIR, TAMPA, FL 33624, Villa I/Week 41 in Unit No. 005315/Principal Balance: \$8,446.52 / Mtg Doc #20160471787  
 Contract Number: 6553878 -- SINCLAIR AUVANT PARKER, ("Owner(s)"), PO BOX 12122, WILMINGTON, NC 28405, Villa I/Week 7 in Unit No. 003056/Principal Balance: \$27,446.19 / Mtg Doc #20180204588

Contract Number: 6540005 -- DAVID RODRIGUEZ, ("Owner(s)"), 4470 THOROUGHbred TRl, SPRINGDALE, AR 72764, Villa I/Week 17 in Unit No. 003045/Principal Balance: \$28,411.01 / Mtg Doc #20190321630  
 Contract Number: 6555047 -- JORGE F ROMO and MARIA MAGDALENA FERREIRA, ("Owner(s)"), 5050 NW 7TH ST APT 209, MIAMI, FL 33126, Villa I/Week 30 in Unit No. 000315/Principal Balance: \$26,883.92 / Mtg Doc #20180396711  
 Contract Number: 6273982 -- WILLIAM HARVEY WAUGH and JANE ELIZABETH WAUGH, ("Owner(s)"), 18569 SE 19TH ST, SILVER SPRINGS, FL 34488, Villa I/Week 2 in Unit No. 000350/Principal Balance: \$12,453.63 / Mtg Doc #20150208991  
 You have the right to cure the default by paying the full amount set forth above plus per diem as accrued to the date of payment, on or before the 30th day after the date of this notice. If payment is not received within such 30-day period, additional amounts will be due. The full amount has to be paid with your credit card by calling Holiday Inn Club Vacations Incorporated F/K/A Orange Lake Country Club, Inc., at 866-714-8679.  
 Failure to cure the default set forth herein or take other appropriate action regarding this matter will result in the loss of ownership of the timeshare through the trustee foreclosure procedure set forth in F.S. 721.856. You have the right to submit an objection form, exercising your right to object to the use of trustee foreclosure procedure. If the objection is filed this matter shall be subject to the to the judicial foreclosure procedure only. The default may be cured any time before the trustee's sale of your timeshare interest. If you do not object to the use of trustee foreclosure procedure, you will not be subject to a deficiency judgment even if the proceeds from the sale of your timeshare interest are sufficient to offset the amounts secured by the lien.  
 Pursuant to the Fair Debt Collection Practices Act, it is required that we state the following: THIS IS AN ATTEMPT TO COLLECT A DEBT AND ANY INFORMATION OBTAINED WILL BE USED FOR THAT PURPOSE.  
 By: Jerry E. Aron, P.A., Trustee, 2505 Metrocentre Blvd, Ste 301, West Palm Beach, FL 33407  
 September 9, 16, 2021 21-03305W

April 23, 2021

### NOTICE OF DEFAULT AND INTENT TO FORECLOSE

Jerry E. Aron, P.A. has been appointed as Trustee by Holiday Inn Club Vacations Incorporated for the purposes of instituting a Trustee Foreclosure and Sale under Florida Statutes 721.856. The obligors listed below are hereby notified that you are in default on your account by failing to make the required payments pursuant to your Promissory Note. Your failure to make timely payments resulted in you defaulting on the Note/Mortgage.

**TIMESHARE PLAN: ORANGE LAKE LAND TRUST**  
 Type of Interest(s), as described below, in the Orange Lake Land Trust, evidenced for administrative, assessment and ownership purposes by Number of Points, as described below, which Trust was created pursuant to and further described in that certain Trust Agreement for Orange Lake Land Trust dated December 15, 2017, executed by and among Chicago Title Timeshare Land Trust, Inc., a Florida Corporation, as the trustee of the Trust, Holiday Inn Club Vacations Incorporated, a Delaware corporation, f/k/a Orange Lake Country Club, Inc., a Delaware corporation, and Orange Lake Trust Owners' Association, Inc., a Florida not-for-profit corporation, as such agreement may be amended and supplemented from time to time, a memorandum of which is recorded in Official Records Document Number: 20180061276, Public Records of Orange County, Florida.  
 Contract Number: 6586515 -- IRENE AYALA and ASHLEY JAZMIN GARCIA, ("Owner(s)"), 10710 SHORE FRONT PKWY APT 10S, ROCKAWAY PARK, NY 11694 and 23 LYNWOOD DR, VALLEY STREAM, NY 11580, STANDARD Interest(s) /50000 Points/ Principal Balance: \$14,228.13 / Mtg Doc #20190085720  
 Contract Number: 6629887 -- JAVEL K. CARRINGTON and DEYANIRIS DIAZ, ("Owner(s)"), 1358 SHERIDAN AVE APT OE, BRONX, NY 10456, STANDARD Interest(s) /50000 Points/ Principal Balance: \$14,566.68 / Mtg Doc #20190139250

Contract Number: 6584020 -- SHERILYN M. ELAM ("Owner(s)"), 5832 FRANKLIN TRl, LIBERTY TWP, OH 45011, STANDARD Interest(s) /150000 Points/ Principal Balance: \$37,659.52 / Mtg Doc #20190264096  
 Contract Number: 6617001 -- JUAN CARLOS MILLER and FRANCES DIANE MILLER, ("Owner(s)"), 15 DAN ST, TAYLORS, SC 29687, STANDARD Interest(s) /50000 Points/ Principal Balance: \$10,134.37 / Mtg Doc #20190143471  
 Contract Number: 6630459 -- SASHANTAE C. WILLIE A/K/A WILLIE S. ("Owner(s)"), 44 KIRK AVE, MONTAUK, NY 11954, STANDARD Interest(s) /50000 Points/ Principal Balance: \$14,289.54 / Mtg Doc #20190187417  
 You have the right to cure the default by paying the full amount set forth above plus per diem as accrued to the date of payment, on or before the 30th day after the date of this notice. If payment is not received within such 30-day period, additional amounts will be due. The full amount has to be paid with your credit card by calling Holiday Inn Club Vacations Incorporated at 866-714-8679.  
 Failure to cure the default set forth herein or take other appropriate action regarding this matter will result in the loss of ownership of the timeshare through the trustee foreclosure procedure set forth in F.S. 721.856. You have the right to submit an objection form, exercising your right to object to the use of trustee foreclosure procedure. If the objection is filed this matter shall be subject to the to the judicial foreclosure procedure only. The default may be cured any time before the trustee's sale of your timeshare interest. If you do not object to the use of trustee foreclosure procedure, you will not be subject to a deficiency judgment even if the proceeds from the sale of your timeshare interest are sufficient to offset the amounts secured by the lien.  
 Pursuant to the Fair Debt Collection Practices Act, it is required that we state the following: THIS IS AN ATTEMPT TO COLLECT A DEBT AND ANY INFORMATION OBTAINED WILL BE USED FOR THAT PURPOSE.  
 By: Jerry E. Aron, P.A., Trustee, 2505 Metrocentre Blvd, Ste 301, West Palm Beach, FL 33407  
 September 9, 16, 2021 21-03308W

# ORANGE COUNTY

## SUBSEQUENT INSERTIONS

**SECOND INSERTION**  
**NOTICE OF APPLICATION FOR TAX DEED**  
 NOTICE IS HEREBY GIVEN that TRACY POWELL the holder of the following certificate has filed said certificate for a TAX DEED to be issued thereon. The Certificate number and year of issuance, the description of the property, and the names in which it was assessed are as follows:  
 CERTIFICATE NUMBER: 2014-258  
 YEAR OF ISSUANCE: 2014  
 DESCRIPTION OF PROPERTY: BEG 279 FT S & 149.1 FT W OF NE COR OF SE1/4 OF SW1/4 OF NE1/4 RUN W 59.2 FT S 84.1 FT ELY TO PT 149.1 FT W OF E LINE OF SW1/4 OF NE1/4 N TO POB IN SEC 21-20-27  
 PARCEL ID # 21-20-27-0000-00-024  
 Name in which assessed: G W SMITH, ANNIE LEE SMITH  
 ALL of said property being in the County of Orange, State of Florida. Unless such certificate shall be redeemed according to law, the property described in such certificate will be sold to the highest bidder online at www.orange.realtaxdeed.com scheduled to begin at 10:00 a.m. ET, Oct 14, 2021.  
 Dated: Aug 26, 2021  
 Phil Diamond  
 County Comptroller  
 Orange County, Florida  
 By: M Hildebrandt  
 Deputy Comptroller  
 September 2, 9, 16, 23, 2021  
 21-02937W

**SECOND INSERTION**  
**NOTICE OF APPLICATION FOR TAX DEED**  
 NOTICE IS HEREBY GIVEN that RAYMOND P RHODE the holder of the following certificate has filed said certificate for a TAX DEED to be issued thereon. The Certificate number and year of issuance, the description of the property, and the names in which it was assessed are as follows:  
 CERTIFICATE NUMBER: 2014-24021  
 YEAR OF ISSUANCE: 2014  
 DESCRIPTION OF PROPERTY: ROCKET CITY UNIT 8A Z/106 A/K/A CAPE ORLANDO ESTATES UNIT 8A 1855/292 THE E 75 FT OF W 150 FT OF TR 47  
 PARCEL ID # 23-23-32-9630-00-471  
 Name in which assessed: SERGIO BALBIN, CICELY BALBIN  
 ALL of said property being in the County of Orange, State of Florida. Unless such certificate shall be redeemed according to law, the property described in such certificate will be sold to the highest bidder online at www.orange.realtaxdeed.com scheduled to begin at 10:00 a.m. ET, Oct 14, 2021.  
 Dated: Aug 26, 2021  
 Phil Diamond  
 County Comptroller  
 Orange County, Florida  
 By: M Hildebrandt  
 Deputy Comptroller  
 September 2, 9, 16, 23, 2021  
 21-02938W

**SECOND INSERTION**  
**NOTICE OF APPLICATION FOR TAX DEED**  
 NOTICE IS HEREBY GIVEN that RAYMOND P RHODE the holder of the following certificate has filed said certificate for a TAX DEED to be issued thereon. The Certificate number and year of issuance, the description of the property, and the names in which it was assessed are as follows:  
 CERTIFICATE NUMBER: 2014-24111  
 YEAR OF ISSUANCE: 2014  
 DESCRIPTION OF PROPERTY: ROCKET CITY UNIT 4A Z/110 A/K/A CAPE ORLANDO ESTATES UNIT 4A 1855/292 THE E 75 FT OF TR 64  
 PARCEL ID # 25-23-32-9632-00-641  
 Name in which assessed: CAROL T RICH  
 ALL of said property being in the County of Orange, State of Florida. Unless such certificate shall be redeemed according to law, the property described in such certificate will be sold to the highest bidder online at www.orange.realtaxdeed.com scheduled to begin at 10:00 a.m. ET, Oct 14, 2021.  
 Dated: Aug 26, 2021  
 Phil Diamond  
 County Comptroller  
 Orange County, Florida  
 By: M Hildebrandt  
 Deputy Comptroller  
 September 2, 9, 16, 23, 2021  
 21-02939W

**SECOND INSERTION**  
**NOTICE OF APPLICATION FOR TAX DEED**  
 NOTICE IS HEREBY GIVEN that RAYMOND P RHODE the holder of the following certificate has filed said certificate for a TAX DEED to be issued thereon. The Certificate number and year of issuance, the description of the property, and the names in which it was assessed are as follows:  
 CERTIFICATE NUMBER: 2014-24132  
 YEAR OF ISSUANCE: 2014  
 DESCRIPTION OF PROPERTY: ROCKET CITY UNIT 4A Z/110 A/K/A CAPE ORLANDO ESTATES UNIT 4A 1855/292 THE E 75 FT OF W 300 FT OF TR 95  
 PARCEL ID # 25-23-32-9632-00-952  
 Name in which assessed: PARAGON MORTGAGE HOLDINGS LLC  
 ALL of said property being in the County of Orange, State of Florida. Unless such certificate shall be redeemed according to law, the property described in such certificate will be sold to the highest bidder online at www.orange.realtaxdeed.com scheduled to begin at 10:00 a.m. ET, Oct 14, 2021.  
 Dated: Aug 26, 2021  
 Phil Diamond  
 County Comptroller  
 Orange County, Florida  
 By: M Hildebrandt  
 Deputy Comptroller  
 September 2, 9, 16, 23, 2021  
 21-02940W

**SECOND INSERTION**  
**NOTICE OF APPLICATION FOR TAX DEED**  
 NOTICE IS HEREBY GIVEN that SUNSHINE STATE CERT VII LLLP the holder of the following certificate has filed said certificate for a TAX DEED to be issued thereon. The Certificate number and year of issuance, the description of the property, and the names in which it was assessed are as follows:  
 CERTIFICATE NUMBER: 2018-16923  
 YEAR OF ISSUANCE: 2018  
 DESCRIPTION OF PROPERTY: SPRING VILLAGE 28/95 LOT 70  
 PARCEL ID # 12-23-30-8259-00-700  
 Name in which assessed: NDAIZIWEI K CHIPUNGU  
 ALL of said property being in the County of Orange, State of Florida. Unless such certificate shall be redeemed according to law, the property described in such certificate will be sold to the highest bidder online at www.orange.realtaxdeed.com scheduled to begin at 10:00 a.m. ET, Oct 14, 2021.  
 Dated: Aug 26, 2021  
 Phil Diamond  
 County Comptroller  
 Orange County, Florida  
 By: M Hildebrandt  
 Deputy Comptroller  
 September 2, 9, 16, 23, 2021  
 21-02941W

**SECOND INSERTION**  
**NOTICE OF APPLICATION FOR TAX DEED**  
 NOTICE IS HEREBY GIVEN that RELIANCE LOAN FUNDING LLC the holder of the following certificate has filed said certificate for a TAX DEED to be issued thereon. The Certificate number and year of issuance, the description of the property, and the names in which it was assessed are as follows:  
 CERTIFICATE NUMBER: 2018-19888  
 YEAR OF ISSUANCE: 2018  
 DESCRIPTION OF PROPERTY: 6135/3279 ERROR IN LEGAL DESCRIPTION -- CAPE ORLANDO ESTATES UNIT 31A 3/110 LOT 20 BLK 1  
 PARCEL ID # 02-23-32-1221-10-200  
 Name in which assessed: JOHN ORTEGA  
 ALL of said property being in the County of Orange, State of Florida. Unless such certificate shall be redeemed according to law, the property described in such certificate will be sold to the highest bidder online at www.orange.realtaxdeed.com scheduled to begin at 10:00 a.m. ET, Oct 14, 2021.  
 Dated: Aug 26, 2021  
 Phil Diamond  
 County Comptroller  
 Orange County, Florida  
 By: M Hildebrandt  
 Deputy Comptroller  
 September 2, 9, 16, 23, 2021  
 21-02942W

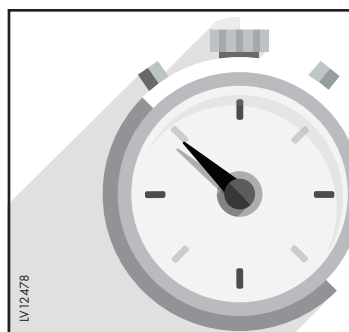

# SAVE TIME

## EMAIL YOUR LEGAL NOTICES

Sarasota County • Manatee County • Hillsborough County • Charlotte County • Pinellas County  
 Pasco County • Polk County • Lee County • Collier County • Orange County  
 legal@businessobserverfl.com



Wednesday 2pm Deadline for Friday Publication | Wednesday 10am for Thursday Publication in Orange County

## ORANGE COUNTY SUBSEQUENT INSERTIONS

<p style="text-align: center;"><b>SECOND INSERTION</b></p> <p style="text-align: center;">NOTICE OF APPLICATION FOR TAX DEED</p> <p>NOTICE IS HEREBY GIVEN that MERIDIAN TAX the holder of the following certificate has filed said certificate for a TAX DEED to be issued thereon. The Certificate number and year of issuance, the description of the property, and the names in which it was assessed are as follows:</p> <p>CERTIFICATE NUMBER: 2019-61</p> <p>YEAR OF ISSUANCE: 2019</p> <p>DESCRIPTION OF PROPERTY: TANGERINE MISC 3/599 N1/2 OF LOT 7 &amp; ALL OF LOTS 8 &amp; 9 BLK 2</p> <p>PARCEL ID # 08-20-27-8559-02-080</p> <p>Name in which assessed: NUVIEW IRA FBO</p> <p>ALL of said property being in the County of Orange, State of Florida. Unless such certificate shall be redeemed according to law, the property described in such certificate will be sold to the highest bidder online at www.orange.realtaxdeed.com scheduled to begin at 10:00 a.m. ET, Oct 14, 2021.</p> <p>Dated: Aug 26, 2021 Phil Diamond County Comptroller Orange County, Florida By: M Hildebrandt Deputy Comptroller September 2, 9, 16, 23, 2021</p> <p style="text-align: right;">21-02943W</p>	<p style="text-align: center;"><b>SECOND INSERTION</b></p> <p style="text-align: center;">NOTICE OF APPLICATION FOR TAX DEED</p> <p>NOTICE IS HEREBY GIVEN that SUNSHINE STATE CERT VII LLLP the holder of the following certificate has filed said certificate for a TAX DEED to be issued thereon. The Certificate number and year of issuance, the description of the property, and the names in which it was assessed are as follows:</p> <p>CERTIFICATE NUMBER: 2019-683</p> <p>YEAR OF ISSUANCE: 2019</p> <p>DESCRIPTION OF PROPERTY: E 273 FT OF W 773 FT OF S 275 FT OF SW1/4 OF SE1/4 (LESS S 75 FT FOR ST RD) OF SEC 22-22-27</p> <p>PARCEL ID # 22-22-27-0000-00-057</p> <p>Name in which assessed: SHAZAD A NESARALLI, OMAWATIE NESARALLI</p> <p>ALL of said property being in the County of Orange, State of Florida. Unless such certificate shall be redeemed according to law, the property described in such certificate will be sold to the highest bidder online at www.orange.realtaxdeed.com scheduled to begin at 10:00 a.m. ET, Oct 14, 2021.</p> <p>Dated: Aug 26, 2021 Phil Diamond County Comptroller Orange County, Florida By: M Hildebrandt Deputy Comptroller September 2, 9, 16, 23, 2021</p> <p style="text-align: right;">21-02944W</p>	<p style="text-align: center;"><b>SECOND INSERTION</b></p> <p style="text-align: center;">NOTICE OF APPLICATION FOR TAX DEED</p> <p>NOTICE IS HEREBY GIVEN that THORNTON MELLON LLC the holder of the following certificate has filed said certificate for a TAX DEED to be issued thereon. The Certificate number and year of issuance, the description of the property, and the names in which it was assessed are as follows:</p> <p>CERTIFICATE NUMBER: 2019-858</p> <p>YEAR OF ISSUANCE: 2019</p> <p>DESCRIPTION OF PROPERTY: MERCHANTS SUB Q/101 LOTS 1 &amp; 2 BLK D</p> <p>PARCEL ID # 24-22-27-5584-04-010</p> <p>Name in which assessed: PERCIVAL N TAVARES ESTATE</p> <p>ALL of said property being in the County of Orange, State of Florida. Unless such certificate shall be redeemed according to law, the property described in such certificate will be sold to the highest bidder online at www.orange.realtaxdeed.com scheduled to begin at 10:00 a.m. ET, Oct 14, 2021.</p> <p>Dated: Aug 26, 2021 Phil Diamond County Comptroller Orange County, Florida By: M Hildebrandt Deputy Comptroller September 2, 9, 16, 23, 2021</p> <p style="text-align: right;">21-02945W</p>	<p style="text-align: center;"><b>SECOND INSERTION</b></p> <p style="text-align: center;">NOTICE OF APPLICATION FOR TAX DEED</p> <p>NOTICE IS HEREBY GIVEN that DANA H COOK FAMILY PARTNER-SHIP the holder of the following certificate has filed said certificate for a TAX DEED to be issued thereon. The Certificate number and year of issuance, the description of the property, and the names in which it was assessed are as follows:</p> <p>CERTIFICATE NUMBER: 2019-1146</p> <p>YEAR OF ISSUANCE: 2019</p> <p>DESCRIPTION OF PROPERTY: STONEYBROOK WEST UT 4 48/48 LOT 6 BLK 9</p> <p>PARCEL ID # 03-23-27-8234-09-006</p> <p>Name in which assessed: CINDA CRANE</p> <p>ALL of said property being in the County of Orange, State of Florida. Unless such certificate shall be redeemed according to law, the property described in such certificate will be sold to the highest bidder online at www.orange.realtaxdeed.com scheduled to begin at 10:00 a.m. ET, Oct 14, 2021.</p> <p>Dated: Aug 26, 2021 Phil Diamond County Comptroller Orange County, Florida By: M Hildebrandt Deputy Comptroller September 2, 9, 16, 23, 2021</p> <p style="text-align: right;">21-02946W</p>	<p style="text-align: center;"><b>SECOND INSERTION</b></p> <p style="text-align: center;">NOTICE OF APPLICATION FOR TAX DEED</p> <p>NOTICE IS HEREBY GIVEN that MERIDIAN TAX the holder of the following certificate has filed said certificate for a TAX DEED to be issued thereon. The Certificate number and year of issuance, the description of the property, and the names in which it was assessed are as follows:</p> <p>CERTIFICATE NUMBER: 2019-1189</p> <p>YEAR OF ISSUANCE: 2019</p> <p>DESCRIPTION OF PROPERTY: LAKE AVALON GROVES REPLAT H/81 LOT 39H (LESS W 618 FT THEREOF) &amp; (LESS N 350 FT THEREOF) &amp; LOT 40H (LESS N 350 FT THEREOF)</p> <p>PARCEL ID # 06-23-27-4288-08-401</p> <p>Name in which assessed: ORLEAN E NEWBY</p> <p>ALL of said property being in the County of Orange, State of Florida. Unless such certificate shall be redeemed according to law, the property described in such certificate will be sold to the highest bidder online at www.orange.realtaxdeed.com scheduled to begin at 10:00 a.m. ET, Oct 14, 2021.</p> <p>Dated: Aug 26, 2021 Phil Diamond County Comptroller Orange County, Florida By: M Hildebrandt Deputy Comptroller September 2, 9, 16, 23, 2021</p> <p style="text-align: right;">21-02947W</p>	<p style="text-align: center;"><b>SECOND INSERTION</b></p> <p style="text-align: center;">NOTICE OF APPLICATION FOR TAX DEED</p> <p>NOTICE IS HEREBY GIVEN that MERIDIAN TAX the holder of the following certificate has filed said certificate for a TAX DEED to be issued thereon. The Certificate number and year of issuance, the description of the property, and the names in which it was assessed are as follows:</p> <p>CERTIFICATE NUMBER: 2019-1195</p> <p>YEAR OF ISSUANCE: 2019</p> <p>DESCRIPTION OF PROPERTY: LAKE AVALON GROVES REPLAT J/90 E1/2 OF LOT 46D &amp; E 20 FT OF E1/2 OF LOT 35D (LESS N 5 FT THEREOF FOR R/W)</p> <p>PARCEL ID # 06-23-27-4292-04-460</p> <p>Name in which assessed: MERRY NORTON SHARP</p> <p>ALL of said property being in the County of Orange, State of Florida. Unless such certificate shall be redeemed according to law, the property described in such certificate will be sold to the highest bidder online at www.orange.realtaxdeed.com scheduled to begin at 10:00 a.m. ET, Oct 14, 2021.</p> <p>Dated: Aug 26, 2021 Phil Diamond County Comptroller Orange County, Florida By: M Hildebrandt Deputy Comptroller September 2, 9, 16, 23, 2021</p> <p style="text-align: right;">21-02948W</p>
<p style="text-align: center;"><b>SECOND INSERTION</b></p> <p style="text-align: center;">NOTICE OF APPLICATION FOR TAX DEED</p> <p>NOTICE IS HEREBY GIVEN that MERIDIAN TAX the holder of the following certificate has filed said certificate for a TAX DEED to be issued thereon. The Certificate number and year of issuance, the description of the property, and the names in which it was assessed are as follows:</p> <p>CERTIFICATE NUMBER: 2019-1617</p> <p>YEAR OF ISSUANCE: 2019</p> <p>DESCRIPTION OF PROPERTY: GROVE RESORT AND SPA HOTEL CONDOMINIUM 3 20180109061 UNIT 3217</p> <p>PARCEL ID # 31-24-27-3000-32-170</p> <p>Name in which assessed: JAMES OLUREMI ODUBANJO</p> <p>ALL of said property being in the County of Orange, State of Florida. Unless such certificate shall be redeemed according to law, the property described in such certificate will be sold to the highest bidder online at www.orange.realtaxdeed.com scheduled to begin at 10:00 a.m. ET, Oct 14, 2021.</p> <p>Dated: Aug 26, 2021 Phil Diamond County Comptroller Orange County, Florida By: M Hildebrandt Deputy Comptroller September 2, 9, 16, 23, 2021</p> <p style="text-align: right;">21-02949W</p>	<p style="text-align: center;"><b>SECOND INSERTION</b></p> <p style="text-align: center;">NOTICE OF APPLICATION FOR TAX DEED</p> <p>NOTICE IS HEREBY GIVEN that MERIDIAN TAX the holder of the following certificate has filed said certificate for a TAX DEED to be issued thereon. The Certificate number and year of issuance, the description of the property, and the names in which it was assessed are as follows:</p> <p>CERTIFICATE NUMBER: 2019-2385</p> <p>YEAR OF ISSUANCE: 2019</p> <p>DESCRIPTION OF PROPERTY: TOWN OF APOPKA A/109 LOT 23 BLK H</p> <p>PARCEL ID # 09-21-28-0196-80-230</p> <p>Name in which assessed: GARY M GARNER, RUFUS JAMES GARNER, ROVENIA JAMES, KENNETH D GARNER</p> <p>ALL of said property being in the County of Orange, State of Florida. Unless such certificate shall be redeemed according to law, the property described in such certificate will be sold to the highest bidder online at www.orange.realtaxdeed.com scheduled to begin at 10:00 a.m. ET, Oct 14, 2021.</p> <p>Dated: Aug 26, 2021 Phil Diamond County Comptroller Orange County, Florida By: M Hildebrandt Deputy Comptroller September 2, 9, 16, 23, 2021</p> <p style="text-align: right;">21-02950W</p>	<p style="text-align: center;"><b>SECOND INSERTION</b></p> <p style="text-align: center;">NOTICE OF APPLICATION FOR TAX DEED</p> <p>NOTICE IS HEREBY GIVEN that MUNICIPAL POINT CAPITAL LP the holder of the following certificate has filed said certificate for a TAX DEED to be issued thereon. The Certificate number and year of issuance, the description of the property, and the names in which it was assessed are as follows:</p> <p>CERTIFICATE NUMBER: 2019-4037</p> <p>YEAR OF ISSUANCE: 2019</p> <p>DESCRIPTION OF PROPERTY: RIDGE MANOR FIRST ADDITION X/64 LOT 21 BLK L</p> <p>PARCEL ID # 12-22-28-7413-12-210</p> <p>Name in which assessed: JON S ATKINSON, TAMARA J ATKINSON</p> <p>ALL of said property being in the County of Orange, State of Florida. Unless such certificate shall be redeemed according to law, the property described in such certificate will be sold to the highest bidder online at www.orange.realtaxdeed.com scheduled to begin at 10:00 a.m. ET, Oct 14, 2021.</p> <p>Dated: Aug 26, 2021 Phil Diamond County Comptroller Orange County, Florida By: M Hildebrandt Deputy Comptroller September 2, 9, 16, 23, 2021</p> <p style="text-align: right;">21-02951W</p>	<p style="text-align: center;"><b>SECOND INSERTION</b></p> <p style="text-align: center;">NOTICE OF APPLICATION FOR TAX DEED</p> <p>NOTICE IS HEREBY GIVEN that MUNICIPAL POINT CAPITAL LP the holder of the following certificate has filed said certificate for a TAX DEED to be issued thereon. The Certificate number and year of issuance, the description of the property, and the names in which it was assessed are as follows:</p> <p>CERTIFICATE NUMBER: 2019-4307</p> <p>YEAR OF ISSUANCE: 2019</p> <p>DESCRIPTION OF PROPERTY: LAKEVIEW THIRD ADDITION O/126 THE S 25 FT OF LOT 8 &amp; ALL OF LOT 9 BLK A</p> <p>PARCEL ID # 17-22-28-4862-01-090</p> <p>Name in which assessed: MARGARET L NIXON LIFE ESTATE, REM: GERALD LEE NIXON, REM: KYLE ERIC NIXON</p> <p>ALL of said property being in the County of Orange, State of Florida. Unless such certificate shall be redeemed according to law, the property described in such certificate will be sold to the highest bidder online at www.orange.realtaxdeed.com scheduled to begin at 10:00 a.m. ET, Oct 14, 2021.</p> <p>Dated: Aug 26, 2021 Phil Diamond County Comptroller Orange County, Florida By: M Hildebrandt Deputy Comptroller September 2, 9, 16, 23, 2021</p> <p style="text-align: right;">21-02952W</p>	<p style="text-align: center;"><b>SECOND INSERTION</b></p> <p style="text-align: center;">NOTICE OF APPLICATION FOR TAX DEED</p> <p>NOTICE IS HEREBY GIVEN that JPL INVESTMENTS CORP the holder of the following certificate has filed said certificate for a TAX DEED to be issued thereon. The Certificate number and year of issuance, the description of the property, and the names in which it was assessed are as follows:</p> <p>CERTIFICATE NUMBER: 2019-4469</p> <p>YEAR OF ISSUANCE: 2019</p> <p>DESCRIPTION OF PROPERTY: LAKE SHORE GARDENS 2ND ADDITION 5/10 LOT 146</p> <p>PARCEL ID # 20-22-28-4828-01-460</p> <p>Name in which assessed: RUTH MILDRED BOWNESS REVOCABLE TRUST</p> <p>ALL of said property being in the County of Orange, State of Florida. Unless such certificate shall be redeemed according to law, the property described in such certificate will be sold to the highest bidder online at www.orange.realtaxdeed.com scheduled to begin at 10:00 a.m. ET, Oct 14, 2021.</p> <p>Dated: Aug 26, 2021 Phil Diamond County Comptroller Orange County, Florida By: M Hildebrandt Deputy Comptroller September 2, 9, 16, 23, 2021</p> <p style="text-align: right;">21-02953W</p>	<p style="text-align: center;"><b>SECOND INSERTION</b></p> <p style="text-align: center;">NOTICE OF APPLICATION FOR TAX DEED</p> <p>NOTICE IS HEREBY GIVEN that GS-RAN-Z LLC the holder of the following certificate has filed said certificate for a TAX DEED to be issued thereon. The Certificate number and year of issuance, the description of the property, and the names in which it was assessed are as follows:</p> <p>CERTIFICATE NUMBER: 2019-5916</p> <p>YEAR OF ISSUANCE: 2019</p> <p>DESCRIPTION OF PROPERTY: ISLEWORTH 4TH AMENDMENT 48/114 PT OF LOT 70 DESC AS BEG NW COR SAID LOT 70 ON A CURVE CONCAVE NELY W/ RAD OF 450 FT &amp; CHORD BEARING OF N54-18-00W TH NWLY THROUGH CENT ANG OF 26-02-50 FOR 204.57 FT TH S48-43-25W 15 FT S23-33-10W 291.33 FT TO A NON-TAN CURVE CONCAVE SWLY W/ RAD OF 60 FT TH SELY THROUGH CENT ANG OF 66-18-23 FOR 69.44 FT TH N89-51-33E 256.89 FT N00-08-27W 212.83 FT TO POB</p> <p>PARCEL ID # 16-23-28-3905-00-701</p> <p>Name in which assessed: GLOBAL HOLDINGS OF ORLANDO LLC</p> <p>ALL of said property being in the County of Orange, State of Florida. Unless such certificate shall be redeemed according to law, the property described in such certificate will be sold to the highest bidder online at www.orange.realtaxdeed.com scheduled to begin at 10:00 a.m. ET, Oct 14, 2021.</p> <p>Dated: Aug 26, 2021 Phil Diamond County Comptroller Orange County, Florida By: M Hildebrandt Deputy Comptroller September 2, 9, 16, 23, 2021</p> <p style="text-align: right;">21-02960W</p>
<p style="text-align: center;"><b>SECOND INSERTION</b></p> <p style="text-align: center;">NOTICE OF APPLICATION FOR TAX DEED</p> <p>NOTICE IS HEREBY GIVEN that MERIDIAN TAX the holder of the following certificate has filed said certificate for a TAX DEED to be issued thereon. The Certificate number and year of issuance, the description of the property, and the names in which it was assessed are as follows:</p> <p>CERTIFICATE NUMBER: 2019-5211</p> <p>YEAR OF ISSUANCE: 2019</p> <p>DESCRIPTION OF PROPERTY: AZUR AT METROWEST CONDOMINIUM 8641/1867 UNIT 1201</p> <p>PARCEL ID # 36-22-28-0199-12-010</p> <p>Name in which assessed: SHEIKH AIZAZ RASHEED</p> <p>ALL of said property being in the County of Orange, State of Florida. Unless such certificate shall be redeemed according to law, the property described in such certificate will be sold to the highest bidder online at www.orange.realtaxdeed.com scheduled to begin at 10:00 a.m. ET, Oct 14, 2021.</p> <p>Dated: Aug 26, 2021 Phil Diamond County Comptroller Orange County, Florida By: M Hildebrandt Deputy Comptroller September 2, 9, 16, 23, 2021</p> <p style="text-align: right;">21-02955W</p>	<p style="text-align: center;"><b>SECOND INSERTION</b></p> <p style="text-align: center;">NOTICE OF APPLICATION FOR TAX DEED</p> <p>NOTICE IS HEREBY GIVEN that GS-RAN-Z LLC the holder of the following certificate has filed said certificate for a TAX DEED to be issued thereon. The Certificate number and year of issuance, the description of the property, and the names in which it was assessed are as follows:</p> <p>CERTIFICATE NUMBER: 2019-5265</p> <p>YEAR OF ISSUANCE: 2019</p> <p>DESCRIPTION OF PROPERTY: FOUNTAINS AT METRO WEST CONDOMINIUM 8594/3449 UNIT 1612 BLDG 16</p> <p>PARCEL ID # 36-22-28-2857-16-120</p> <p>Name in which assessed: RESE FLORIDA LLC</p> <p>ALL of said property being in the County of Orange, State of Florida. Unless such certificate shall be redeemed according to law, the property described in such certificate will be sold to the highest bidder online at www.orange.realtaxdeed.com scheduled to begin at 10:00 a.m. ET, Oct 14, 2021.</p> <p>Dated: Aug 26, 2021 Phil Diamond County Comptroller Orange County, Florida By: M Hildebrandt Deputy Comptroller September 2, 9, 16, 23, 2021</p> <p style="text-align: right;">21-02956W</p>	<p style="text-align: center;"><b>SECOND INSERTION</b></p> <p style="text-align: center;">NOTICE OF APPLICATION FOR TAX DEED</p> <p>NOTICE IS HEREBY GIVEN that GS-RAN-Z LLC the holder of the following certificate has filed said certificate for a TAX DEED to be issued thereon. The Certificate number and year of issuance, the description of the property, and the names in which it was assessed are as follows:</p> <p>CERTIFICATE NUMBER: 2019-5729</p> <p>YEAR OF ISSUANCE: 2019</p> <p>DESCRIPTION OF PROPERTY: STONEBRIDGE RESERVE CONDOMINIUM PHASE 2 8935/3093 UNIT 20202</p> <p>PARCEL ID # 12-23-28-8182-20-202</p> <p>Name in which assessed: ACV ENTERPRISES LLC</p> <p>ALL of said property being in the County of Orange, State of Florida. Unless such certificate shall be redeemed according to law, the property described in such certificate will be sold to the highest bidder online at www.orange.realtaxdeed.com scheduled to begin at 10:00 a.m. ET, Oct 14, 2021.</p> <p>Dated: Aug 26, 2021 Phil Diamond County Comptroller Orange County, Florida By: M Hildebrandt Deputy Comptroller September 2, 9, 16, 23, 2021</p> <p style="text-align: right;">21-02957W</p>	<p style="text-align: center;"><b>SECOND INSERTION</b></p> <p style="text-align: center;">NOTICE OF APPLICATION FOR TAX DEED</p> <p>NOTICE IS HEREBY GIVEN that MUNICIPAL POINT CAPITAL LP the holder of the following certificate has filed said certificate for a TAX DEED to be issued thereon. The Certificate number and year of issuance, the description of the property, and the names in which it was assessed are as follows:</p> <p>CERTIFICATE NUMBER: 2019-5808</p> <p>YEAR OF ISSUANCE: 2019</p> <p>DESCRIPTION OF PROPERTY: WINDERMERE BUSINESS CENTER CONDOMINIUM 9741/6450 UNIT 414</p> <p>PARCEL ID # 12-23-28-8606-00-414</p> <p>Name in which assessed: ORLANDO SMILES INC</p> <p>ALL of said property being in the County of Orange, State of Florida. Unless such certificate shall be redeemed according to law, the property described in such certificate will be sold to the highest bidder online at www.orange.realtaxdeed.com scheduled to begin at 10:00 a.m. ET, Oct 14, 2021.</p> <p>Dated: Aug 26, 2021 Phil Diamond County Comptroller Orange County, Florida By: M Hildebrandt Deputy Comptroller September 2, 9, 16, 23, 2021</p> <p style="text-align: right;">21-02958W</p>	<p style="text-align: center;"><b>SECOND INSERTION</b></p> <p style="text-align: center;">NOTICE OF APPLICATION FOR TAX DEED</p> <p>NOTICE IS HEREBY GIVEN that MERIDIAN TAX the holder of the following certificate has filed said certificate for a TAX DEED to be issued thereon. The Certificate number and year of issuance, the description of the property, and the names in which it was assessed are as follows:</p> <p>CERTIFICATE NUMBER: 2019-5847</p> <p>YEAR OF ISSUANCE: 2019</p> <p>DESCRIPTION OF PROPERTY: WINDHOVER CONDO CB 2/70 UNIT C01-1 BLDG 23</p> <p>PARCEL ID # 13-23-28-9358-23-001</p> <p>Name in which assessed: EL HOU-CINE BARSIS, ZAMENNA HUSSAIN</p> <p>ALL of said property being in the County of Orange, State of Florida. Unless such certificate shall be redeemed according to law, the property described in such certificate will be sold to the highest bidder online at www.orange.realtaxdeed.com scheduled to begin at 10:00 a.m. ET, Oct 14, 2021.</p> <p>Dated: Aug 26, 2021 Phil Diamond County Comptroller Orange County, Florida By: M Hildebrandt Deputy Comptroller September 2, 9, 16, 23, 2021</p> <p style="text-align: right;">21-02959W</p>	<p style="text-align: center;"><b>SECOND INSERTION</b></p> <p style="text-align: center;">NOTICE OF APPLICATION FOR TAX DEED</p> <p>NOTICE IS HEREBY GIVEN that MERIDIAN TAX the holder of the following certificate has filed said certificate for a TAX DEED to be issued thereon. The Certificate number and year of issuance, the description of the property, and the names in which it was assessed are as follows:</p> <p>CERTIFICATE NUMBER: 2019-5916</p> <p>YEAR OF ISSUANCE: 2019</p> <p>DESCRIPTION OF PROPERTY: ISLEWORTH 4TH AMENDMENT 48/114 PT OF LOT 70 DESC AS BEG NW COR SAID LOT 70 ON A CURVE CONCAVE NELY W/ RAD OF 450 FT &amp; CHORD BEARING OF N54-18-00W TH NWLY THROUGH CENT ANG OF 26-02-50 FOR 204.57 FT TH S48-43-25W 15 FT S23-33-10W 291.33 FT TO A NON-TAN CURVE CONCAVE SWLY W/ RAD OF 60 FT TH SELY THROUGH CENT ANG OF 66-18-23 FOR 69.44 FT TH N89-51-33E 256.89 FT N00-08-27W 212.83 FT TO POB</p> <p>PARCEL ID # 16-23-28-3905-00-701</p> <p>Name in which assessed: GLOBAL HOLDINGS OF ORLANDO LLC</p> <p>ALL of said property being in the County of Orange, State of Florida. Unless such certificate shall be redeemed according to law, the property described in such certificate will be sold to the highest bidder online at www.orange.realtaxdeed.com scheduled to begin at 10:00 a.m. ET, Oct 14, 2021.</p> <p>Dated: Aug 26, 2021 Phil Diamond County Comptroller Orange County, Florida By: M Hildebrandt Deputy Comptroller September 2, 9, 16, 23, 2021</p> <p style="text-align: right;">21-02960W</p>





**ORANGE COUNTY**  
**SUBSEQUENT INSERTIONS**

SECOND INSERTION

IN THE CIRCUIT COURT, IN AND FOR ORANGE COUNTY, FLORIDA.

**CASE NO.: 21-CA-005649-O #36**  
**HOLIDAY INN CLUB VACATIONS INCORPORATED**  
**Plaintiff, vs.**  
**STANFIELD ET.AL.,**  
**Defendant(s).**

NOTICE OF ACTION  
Count VIII  
To: GEOVANNI ANTONIO VEGA CORDERO and JOAQUINITA ARROYO FONSECA

And all parties claiming interest by, through, under or against Defendant(s) GEOVANNI ANTONIO VEGA CORDERO and JOAQUINITA ARROYO FONSECA and all parties having or claiming to have any right, title or interest in the property herein described.

YOU ARE NOTIFIED that an action to foreclose a mortgage/claim of lien on the following described property:

STANDARD Interest(s) in the Orange Lake Land Trust ("Trust") evidenced for administrative, assessment and ownership purposes by 80000 points, which Trust was created pursuant to and further described in that certain Trust Agreement for Orange Lake Land Trust dated December 15, 2017, executed by and among Chicago Title Time-share Land Trust, Inc., a Florida Corporation, as the trustee of the Trust, Holiday Inn Club Vacations Incorporated, a Delaware corporation, f/k/a Orange Lake Country Club, Inc., a Delaware corporation, and Orange Lake Trust Owners' Association, Inc., a Florida not-for-profit corporation, as such agreement may be amended and supplemented from time to time ("Trust Agreement"), a memorandum of which is recorded in Official Records Document Number: 20180061276, Public Records of

Orange County, Florida ("Memorandum of Trust") All of the terms, restrictions, covenants, conditions and provisions contained in the Declaration and any amendments thereto, are incorporated herein by reference with the same effect as though fully set forth herein.

has been filed against you and you are required to serve a copy of your written defenses, if any, to it on Jerry E. Aron, Plaintiff's attorney, whose address is 2505 Metrocentre Blvd., Suite 301, West Palm Beach, Florida, 33407, within thirty (30) days after the first publication of this Notice, and file the original with the Clerk of this Court either before service on Plaintiff's attorney or immediately thereafter, otherwise a default will be entered against you for the relief demanded in the Complaint.

If you are a person with disability who needs any accommodation in order to participate in a court proceeding or event, you are entitled, at no cost to you, to the provision of certain assistance. Please contact: in Orange County, ADA Coordinator, Human Resources, Orange County Courthouse, 425 N. Orange Avenue, Suite 510, Orlando, Florida, (407) 836-2303, fax: 407-836-2204; at least 7 days before your scheduled court appearance, or immediately upon receiving notification if the time before the scheduled court appearance is less than 7 days. If you are hearing or voice impaired, call 711 to reach the Telecommunications Relay Service.

TIFFANY MOORE RUSSELL  
CLERK OF THE CIRCUIT COURT  
ORANGE COUNTY, FLORIDA  
8/19/2021  
/s/ Lisa Geib  
DEPUTY CLERK  
425 North Orange Ave.  
Suite 350  
Orlando, Florida 32801  
September 2, 9, 2021 21-03155W

SECOND INSERTION

IN THE CIRCUIT COURT, IN AND FOR ORANGE COUNTY, FLORIDA.

**CASE NO.: 21-CA-005972-O #39**  
**HOLIDAY INN CLUB VACATIONS INCORPORATED**  
**Plaintiff, vs.**  
**DUARTE VALENCIA ET.AL.,**  
**Defendant(s).**

NOTICE OF ACTION  
Count III  
To: DIEGO ALEJANDRO GALLEGO ARROYAVE

And all parties claiming interest by, through, under or against Defendant(s) DIEGO ALEJANDRO GALLEGO ARROYAVE and all parties having or claiming to have any right, title or interest in the property herein described:

YOU ARE NOTIFIED that an action to foreclose a mortgage/claim of lien on the following described property in Orange County, Florida:

WEEK/UNIT:  
45/002627  
of Orange Lake Country Club Villas II, a Condominium, together with an undivided interest in the common elements appurtenant thereto, according to the Declaration of Condominium thereof recorded in Official Records Book 4846, Page 1619, in the Public Records of Orange County, Florida, and all amendments thereto; the plat of which is recorded in Condominium Book 22, page 132-146 until 12:00 noon on the first Saturday 2061, at which date said estate shall terminate; TOGETHER with a remainder over in fee simple absolute as tenant in common with the other owners of all the unit weeks in the

above described Condominium in the percentage interest established in the Declaration of Condominium.

has been filed against you and you are required to serve a copy of your written defenses, if any, to it on Jerry E. Aron, Plaintiff's attorney, whose address is 2505 Metrocentre Blvd., Suite 301, West Palm Beach, Florida, 33407, within thirty (30) days after the first publication of this Notice, and file the original with the Clerk of this Court either before service on Plaintiff's attorney or immediately thereafter, otherwise a default will be entered against you for the relief demanded in the Complaint.

If you are a person with disability who needs any accommodation in order to participate in a court proceeding or event, you are entitled, at no cost to you, to the provision of certain assistance. Please contact: in Orange County, ADA Coordinator, Human Resources, Orange County Courthouse, 425 N. Orange Avenue, Suite 510, Orlando, Florida, (407) 836-2303, fax: 407-836-2204; at least 7 days before your scheduled court appearance, or immediately upon receiving notification if the time before the scheduled court appearance is less than 7 days. If you are hearing or voice impaired, call 711 to reach the Telecommunications Relay Service.

TIFFANY MOORE RUSSELL  
CLERK OF THE CIRCUIT COURT  
ORANGE COUNTY, FLORIDA  
August 24th, 2021  
/s/ Liz Yanira Gordian Olmo,  
Deputy Clerk  
425 North Orange Ave.  
Suite 350  
Orlando, Florida 32801  
September 2, 9, 2021 21-03179W

SECOND INSERTION

IN THE CIRCUIT COURT, IN AND FOR ORANGE COUNTY, FLORIDA.

**CASE NO.: 21-CA-006290-O #39**  
**HOLIDAY INN CLUB VACATIONS INCORPORATED**  
**Plaintiff, vs.**  
**MARCELIN ET.AL.,**  
**Defendant(s).**

NOTICE OF ACTION  
Count VII  
To: CLEMENTE C. KING and TOTIS U. KING

And all parties claiming interest by, through, under or against Defendant(s) CLEMENTE C. KING and TOTIS U. KING and all parties having or claiming to have any right, title or interest in the property herein described:

YOU ARE NOTIFIED that an action to foreclose a mortgage/claim of lien on the following described property in Orange County, Florida:

WEEK/UNIT:  
39 ODD/88015  
of Orange Lake Country Club Villas III, a Condominium, together with an undivided interest in the common elements appurtenant thereto, according to the Declaration of Condominium thereof recorded in Official Records Book 5914, Page 1965, in the Public Records of Orange County, Florida, and all amendments thereto; the plat of which is recorded in Condominium Book 28, page 84-92 until 12:00 noon on the first Saturday 2071, at which date said estate shall terminate; TOGETHER with a remainder over in fee simple absolute as tenant in common with the other owners of all the unit

weeks in the above described Condominium in the percentage interest established in the Declaration of Condominium.

has been filed against you and you are required to serve a copy of your written defenses, if any, to it on Jerry E. Aron, Plaintiff's attorney, whose address is 2505 Metrocentre Blvd., Suite 301, West Palm Beach, Florida, 33407, within thirty (30) days after the first publication of this Notice, and file the original with the Clerk of this Court either before service on Plaintiff's attorney or immediately thereafter, otherwise a default will be entered against you for the relief demanded in the Complaint.

If you are a person with disability who needs any accommodation in order to participate in a court proceeding or event, you are entitled, at no cost to you, to the provision of certain assistance. Please contact: in Orange County, ADA Coordinator, Human Resources, Orange County Courthouse, 425 N. Orange Avenue, Suite 510, Orlando, Florida, (407) 836-2303, fax: 407-836-2204; at least 7 days before your scheduled court appearance, or immediately upon receiving notification if the time before the scheduled court appearance is less than 7 days. If you are hearing or voice impaired, call 711 to reach the Telecommunications Relay Service.

(10/14/2021)  
TIFFANY MOORE RUSSELL  
CLERK OF THE CIRCUIT COURT  
ORANGE COUNTY, FLORIDA  
/s/ Nancy Garcia, 8/19/2021  
Deputy Clerk  
425 North Orange Ave.  
Suite 350  
Orlando, Florida 32801  
September 2, 9, 2021 21-03184W

SECOND INSERTION

NOTICE OF ACTION  
IN THE CIRCUIT COURT OF THE 9TH JUDICIAL CIRCUIT, IN AND FOR ORANGE COUNTY, FLORIDA  
CIVIL DIVISION

**CASE NO.: 2021-CA-001419-O**  
**WILMINGTON SAVINGS FUND SOCIETY, FSB, D/B/A CHRISTIANA TRUST AS TRUSTEE FOR PNPMS TRUST II,**  
**Plaintiff, vs.**  
**ASAD YAZDANI A/K/A MOHAMMAD ASAD YAZDANI A/K/A MOHAMMAD A. YAZDANI, et al**  
**Defendants.**

TO: ASAD YAZDANI A/K/A MOHAMMAD ASAD YAZDANI A/K/A MOHAMMAD A. YAZDANI 12705 HAWSTONE DR WINDERMERE, FL 34786  
LAST KNOWN ADDRESS: STATED, CURRENT ADDRESS: UNKNOWN  
UNKNOWN SPOUSE OF ASAD YAZDANI A/K/A MOHAMMAD ASAD YAZDANI A/K/A MOHAMMAD A. YAZDANI 12705 HAWSTONE DR WINDERMERE, FL 34786  
LAST KNOWN ADDRESS: STATED, CURRENT ADDRESS: UNKNOWN  
YOU ARE HEREBY NOTIFIED

that an action to foreclose Mortgage covering the following real and personal property described as follows, to-wit: LOT 328, LAKES OF WINDERMERE PHASE 2A, ACCORDING TO THE PLAT THEREOF, AS RECORDED IN PLAT BOOK 60, PAGES 63-70, OF THE PUBLIC RECORDS OF ORANGE COUNTY, FLORIDA.

has been filed against you and you are required to file a copy of your written defenses, if any, to it on Orlando Deluca, Deluca Law Group, PLLC, 2101 NE 26th Street, Fort Lauderdale, FL 33305 and file the original with the Clerk of the above-styled Court on or before XXXXXXXXXXXX 30 days from the first publication, otherwise a Judgment may be entered against you for the relief demanded in the Complaint.

WITNESS my hand and seal of said Court on the 6 day of July, 2021.  
Tiffany Moore Russell  
CLERK OF THE CIRCUIT COURT  
As Clerk of the Court  
BY: /s/ Sandra Jackson  
Deputy Clerk  
DELUCA LAW GROUP PLLC  
PHONE: (954) 368-1311 |  
FAX: (954) 200-8649  
20-04757-1  
September 2, 9, 2021 21-03231W

SECOND INSERTION

IN THE CIRCUIT COURT, IN AND FOR ORANGE COUNTY, FLORIDA.

**CASE NO.: 21-CA-005976-O #34**  
**HOLIDAY INN CLUB VACATIONS INCORPORATED**  
**Plaintiff, vs.**  
**ALEXIS ET.AL.,**  
**Defendant(s).**

NOTICE OF ACTION  
Count V  
To: BERNARD ASTOR CARTER MIENTES and ROSALINDA RAQUEL VICTORIA NUNEZ FASTLICH

And all parties claiming interest by, through, under or against Defendant(s) BERNARD ASTOR CARTER MIENTES and ROSALINDA RAQUEL VICTORIA NUNEZ FASTLICH and all parties having or claiming to have any right, title or interest in the property herein described:

YOU ARE NOTIFIED that an action to foreclose a mortgage/claim of lien on the following described property in Orange County, Florida:

WEEK/UNIT:  
38 EVEN/5448  
of Orange Lake Country Club Villas II, a Condominium, together with an undivided interest in the common elements appurtenant thereto, according to the Declaration of Condominium thereof recorded in Official Records Book 4846, Page 1619, in the Public Records of Orange County, Florida, and all amendments thereto; the plat of which is recorded in Condominium Book 22, page 132-146 until 12:00 noon on the first Saturday 2061, at which date said estate shall terminate; TOGETHER with a remainder over in fee simple absolute as tenant

in common with the other owners of all the unit weeks in the above described Condominium in the percentage interest established in the Declaration of Condominium.

has been filed against you and you are required to serve a copy of your written defenses, if any, to it on Jerry E. Aron, Plaintiff's attorney, whose address is 2505 Metrocentre Blvd., Suite 301, West Palm Beach, Florida, 33407, within thirty (30) days after the first publication of this Notice, and file the original with the Clerk of this Court either before service on Plaintiff's attorney or immediately thereafter, otherwise a default will be entered against you for the relief demanded in the Complaint.

If you are a person with disability who needs any accommodation in order to participate in a court proceeding or event, you are entitled, at no cost to you, to the provision of certain assistance. Please contact: in Orange County, ADA Coordinator, Human Resources, Orange County Courthouse, 425 N. Orange Avenue, Suite 510, Orlando, Florida, (407) 836-2303, fax: 407-836-2204; at least 7 days before your scheduled court appearance, or immediately upon receiving notification if the time before the scheduled court appearance is less than 7 days. If you are hearing or voice impaired, call 711 to reach the Telecommunications Relay Service.

TIFFANY MOORE RUSSELL  
CLERK OF THE CIRCUIT COURT  
ORANGE COUNTY, FLORIDA  
August 23rd, 2021  
/s/ Liz Yanira Gordian Olmo  
425 North Orange Ave.  
Suite 350  
Orlando, Florida 32801  
September 2, 9, 2021 21-03064W

SECOND INSERTION

IN THE CIRCUIT COURT, IN AND FOR ORANGE COUNTY, FLORIDA.

**CASE NO.: 21-CA-006287-O #33**  
**HOLIDAY INN CLUB VACATIONS INCORPORATED**  
**Plaintiff, vs.**  
**PAOLETTI ET.AL.,**  
**Defendant(s).**

NOTICE OF ACTION  
Count II  
To: BARDEN PAQUETTE AND ANY AND ALL UNKNOWN HEIRS, DEVISEES AND OTHER CLAIMANTS OF BARDEN PAQUETTE

And all parties claiming interest by, through, under or against Defendant(s) BARDEN PAQUETTE AND ANY AND ALL UNKNOWN HEIRS, DEVISEES AND OTHER CLAIMANTS OF BARDEN PAQUETTE and all parties having or claiming to have any right, title or interest in the property herein described:

YOU ARE NOTIFIED that an action to foreclose a mortgage/claim of lien on the following described property in Orange County, Florida:

WEEK/UNIT:  
30 EVEN/88045  
of Orange Lake Country Club Villas III, a Condominium, together with an undivided interest in the common elements appurtenant thereto, according to the Declaration of Condominium thereof recorded in Official Records Book 5914, Page 1965, in the Public Records of Orange County, Florida, and all amendments thereto; the plat of which is recorded in Condominium Book 28, page 84-92 until 12:00 noon on the first Saturday 2071, at which date said estate shall terminate; TOGETHER with a remainder over in fee simple ab-

solute as tenant in common with the other owners of all the unit weeks in the above described Condominium in the percentage interest established in the Declaration of Condominium.

has been filed against you and you are required to serve a copy of your written defenses, if any, to it on Jerry E. Aron, Plaintiff's attorney, whose address is 2505 Metrocentre Blvd., Suite 301, West Palm Beach, Florida, 33407, within thirty (30) days after the first publication of this Notice, and file the original with the Clerk of this Court either before service on Plaintiff's attorney or immediately thereafter, otherwise a default will be entered against you for the relief demanded in the Complaint.

If you are a person with disability who needs any accommodation in order to participate in a court proceeding or event, you are entitled, at no cost to you, to the provision of certain assistance. Please contact: in Orange County, ADA Coordinator, Human Resources, Orange County Courthouse, 425 N. Orange Avenue, Suite 510, Orlando, Florida, (407) 836-2303, fax: 407-836-2204; at least 7 days before your scheduled court appearance, or immediately upon receiving notification if the time before the scheduled court appearance is less than 7 days. If you are hearing or voice impaired, call 711 to reach the Telecommunications Relay Service.

TIFFANY MOORE RUSSELL  
CLERK OF THE CIRCUIT COURT  
ORANGE COUNTY, FLORIDA  
08/19/2021  
/s/ RAMONA VELEZ,  
DEPUTY CLERK  
425 North Orange Ave.  
Suite 350  
Orlando, Florida 32801  
September 2, 9, 2021 21-03042W

SECOND INSERTION

IN THE CIRCUIT COURT, IN AND FOR ORANGE COUNTY, FLORIDA.

**CASE NO.: 21-CA-005974-O #33**  
**HOLIDAY INN CLUB VACATIONS INCORPORATED**  
**Plaintiff, vs.**  
**ALVES NOIA ET.AL.,**  
**Defendant(s).**

NOTICE OF ACTION  
Count III  
To: MAHENDRA APPADU and SAVITA PRASAD AND ANY AND ALL UNKNOWN HEIRS, DEVISEES AND OTHER CLAIMANTS OF SAVITA PRASAD

And all parties claiming interest by, through, under or against Defendant(s) MAHENDRA APPADU and SAVITA PRASAD AND ANY AND ALL UNKNOWN HEIRS, DEVISEES AND OTHER CLAIMANTS OF SAVITA PRASAD and all parties having or claiming to have any right, title or interest in the property herein described:

YOU ARE NOTIFIED that an action to foreclose a mortgage/claim of lien on the following described property in Orange County, Florida:

WEEK/UNIT:  
41/005366  
of Orange Lake Country Club Villas I, a Condominium, together with an undivided interest in the common elements appurtenant thereto, according to the Declaration of Condominium thereof recorded in Official Records Book 3300, Page 2702, in the Public Records of Orange County, Florida, and all amendments thereto; the plat of which is recorded in Condominium Book 7, page 59 until 12:00 noon on the first Saturday 2061, at which date said estate shall terminate; TOGETHER with a

remainder over in fee simple absolute as tenant in common with the other owners of all the unit weeks in the above described Condominium in the percentage interest established in the Declaration of Condominium.

has been filed against you and you are required to serve a copy of your written defenses, if any, to it on Jerry E. Aron, Plaintiff's attorney, whose address is 2505 Metrocentre Blvd., Suite 301, West Palm Beach, Florida, 33407, within thirty (30) days after the first publication of this Notice, and file the original with the Clerk of this Court either before service on Plaintiff's attorney or immediately thereafter, otherwise a default will be entered against you for the relief demanded in the Complaint.

If you are a person with disability who needs any accommodation in order to participate in a court proceeding or event, you are entitled, at no cost to you, to the provision of certain assistance. Please contact: in Orange County, ADA Coordinator, Human Resources, Orange County Courthouse, 425 N. Orange Avenue, Suite 510, Orlando, Florida, (407) 836-2303, fax: 407-836-2204; at least 7 days before your scheduled court appearance, or immediately upon receiving notification if the time before the scheduled court appearance is less than 7 days. If you are hearing or voice impaired, call 711 to reach the Telecommunications Relay Service.

TIFFANY MOORE RUSSELL  
CLERK OF THE CIRCUIT COURT  
ORANGE COUNTY, FLORIDA  
August 23rd, 2021  
/s/ Liz Gordian Olmo  
425 North Orange Ave.  
Suite 350  
Orlando, Florida 32801  
September 2, 9, 2021 21-03019W

SECOND INSERTION

IN THE CIRCUIT COURT, IN AND FOR ORANGE COUNTY, FLORIDA.

**CASE NO.: 21-CA-005640-O #37**  
**HOLIDAY INN CLUB VACATIONS INCORPORATED**  
**Plaintiff, vs.**  
**GARCIA RIVAS ET.AL.,**  
**Defendant(s).**

NOTICE OF ACTION  
Count XII  
To: CRISTIAN ENRIQUE MIRANDA URIZAR and MARCELA SANTANDER VERDUGO

And all parties claiming interest by, through, under or against Defendant(s) CRISTIAN ENRIQUE MIRANDA URIZAR and MARCELA SANTANDER VERDUGO and all parties having or claiming to have any right, title or interest in the property herein described:

YOU ARE NOTIFIED that an action to foreclose a mortgage/claim of lien on the following described property:

STANDARD Interest(s) in the Orange Lake Land Trust

("Trust") evidenced for administrative, assessment and ownership purposes by 60000 points, which Trust was created pursuant to and further described in that certain Trust Agreement for Orange Lake Land Trust dated December 15, 2017, executed by and among Chicago Title Time-share Land Trust, Inc., a Florida Corporation, as the trustee of the Trust, Holiday Inn Club Vacations Incorporated, a Delaware corporation, f/k/a Orange Lake Country Club, Inc., a Delaware corporation, and Orange Lake Trust Owners' Association, Inc., a Florida not-for-profit corporation, as such agreement may be amended and supplemented from time to time ("Trust Agreement"), a memorandum of which is recorded in Official Records Document Number: 20180061276, Public Records of

Orange County, Florida ("Memorandum of Trust") All of the terms, restrictions, covenants, conditions and provisions contained in the Declaration and any amendments thereto, are incorporated herein by reference with the same effect as though fully set forth herein.

has been filed against you and you are required to serve a copy of your written defenses, if any, to it on Jerry E. Aron, Plaintiff's attorney, whose address is 2505 Metrocentre Blvd., Suite 301, West Palm Beach, Florida, 33407, within thirty (30) days after the first publication of this Notice, and file the original with the Clerk of this Court either before service on Plaintiff's attorney or immediately thereafter, otherwise a default will be entered against you for the relief demanded in the Complaint.

If you are a person with disability who needs any accommodation in order to participate in a court proceed-

ing or event, you are entitled, at no cost to you, to the provision of certain assistance. Please contact: in Orange County, ADA Coordinator, Human Resources, Orange County Courthouse, 425 N. Orange Avenue, Suite 510, Orlando, Florida, (407) 836-2303, fax: 407-836-2204; at least 7 days before your scheduled court appearance, or immediately upon receiving notification if the time before the scheduled court appearance is less than 7 days. If you are hearing or voice impaired, call 711 to reach the Telecommunications Relay Service.

TIFFANY MOORE RUSSELL  
CLERK OF THE CIRCUIT COURT  
ORANGE COUNTY, FLORIDA  
August 23rd, 2021  
/s/ Liz Yanira Gordian Olmo  
DEPUTY CLERK  
425 North Orange Ave.  
Suite 350  
Orlando, Florida 32801  
September 2, 9, 2021 21-03167W

**SAVE TIME - EMAIL YOUR LEGAL NOTICES**  
Sarasota County • Manatee County • Hillsborough County • Charlotte County  
Pinellas County • Pasco County • Polk County • Lee County  
Collier County • Orange County  
**legal@businessobserverfl.com**  
Wednesday 2pm Deadline for Friday Publication | Wednesday 10am for Thursday Publication in Orange County















ORANGE COUNTY SUBSEQUENT INSERTIONS

SECOND INSERTION

IN THE CIRCUIT COURT, IN AND FOR ORANGE COUNTY, FLORIDA. CASE NO.: 21-CA-006288-O #34 HOLIDAY INN CLUB VACATIONS INCORPORATED Plaintiff, vs. ARROYO ET.AL., Defendant(s). NOTICE OF ACTION Count VIII To: LEE DENVER FORD and JEAN CAROL ZORNES AND ANY AND ALL UNKNOWN HEIRS, DEVISEES AND OTHER CLAIMANTS OF JEAN CAROL ZORNES And all parties claiming interest by, through, under or against Defendant(s) LEE DENVER FORD and JEAN CAROL ZORNES AND ANY AND ALL UNKNOWN HEIRS, DEVISEES AND OTHER CLAIMANTS OF JEAN CAROL ZORNES and all parties having or claiming to have any right, title or interest in the property herein described: YOU ARE NOTIFIED that an action to foreclose a mortgage/claim of lien on the following described property in Orange County, Florida: WEEK/UNIT: 42 EVEN/87545 of Orange Lake Country Club Villas III, a Condominium, to-

gether with an undivided interest in the common elements appurtenant thereto, according to the Declaration of Condominium thereof recorded in Official Records Book 5914, Page 1965, in the Public Records of Orange County, Florida, and all amendments thereto; the plat of which is recorded in Condominium Book 28, page 84-92 until 12:00 noon on the first Saturday 2071, at which date said estate shall terminate; TOGETHER with a remainder over in fee simple absolute as tenant in common with the other owners of all the unit weeks in the above described Condominium in the percentage interest established in the Declaration of Condominium. has been filed against you and you are required to serve a copy of your written defenses, if any, to it on Jerry E. Aron, Plaintiff's attorney, whose address is 2505 Metrocentre Blvd., Suite 301, West Palm Beach, Florida, 33407, within thirty (30) days after the first publication of this Notice, and file the original with the Clerk of this Court either before service on Plaintiff's attorney or immediately thereafter, otherwise a default will be entered against you for the relief demanded in the Complaint.

TIFFANY MOORE RUSSELL CLERK OF THE CIRCUIT COURT ORANGE COUNTY, FLORIDA (10/14/2021) /s/ Nancy Garcia, 8/19/2021 DEPUTY CLERK 425 North Orange Ave. Suite 350 Orlando, Florida 32801 September 2, 9, 2021 21-03081W

SECOND INSERTION

IN THE CIRCUIT COURT, IN AND FOR ORANGE COUNTY, FLORIDA. CASE NO.: 21-CA-006285-O #36 HOLIDAY INN CLUB VACATIONS INCORPORATED Plaintiff, vs. MOHAMED ELSANGEDY ET.AL., Defendant(s). NOTICE OF ACTION Count V To: JAVIER OLIVERIO RUIZ JORDAN AND all parties claiming interest by, through, under or against Defendant(s) JAVIER OLIVERIO RUIZ JORDAN and all parties having or claiming to have any right, title or interest in the property herein described. YOU ARE NOTIFIED that an action to foreclose a mortgage/claim of lien on the following described property : STANDARD Interest(s) in the Orange Lake Land Trust ("Trust") evidenced for administrative, assessment and ownership purposes by 75000 points, which Trust was created pursuant to and further described in that certain Trust Agreement for Orange Lake Land Trust dated December 15, 2017, executed by and among Chicago Title Time-share Land Trust, Inc., a Florida Corporation, as the trustee of the Trust, Holiday Inn Club Vacations Incorporated, a Delaware corporation, f/k/a Orange Lake Country Club, Inc., a Delaware corporation, and Orange Lake Trust Owners' Association, Inc., a Florida not-for-profit corporation, as such agreement may be amended and supplemented from time to time ("Trust Agreement"), a memorandum of which is recorded in Official Records Document Number: 20180061276, Public Records of Orange County, Florida ("Mem-

randum of Trust")All of the terms, restrictions, covenants, conditions and provisions contained in the Declaration and any amendments thereto, are incorporated herein by reference with the same effect as though fully set forth herein. has been filed against you and you are required to serve a copy of your written defenses, if any, to it on Jerry E. Aron, Plaintiff's attorney, whose address is 2505 Metrocentre Blvd., Suite 301, West Palm Beach, Florida, 33407, within thirty (30) days after the first publication of this Notice, and file the original with the Clerk of this Court either before service on Plaintiff's attorney or immediately thereafter, otherwise a default will be entered against you for the relief demanded in the Complaint. If you are a person with disability who needs any accommodation in order to participate in a court proceeding or event, you are entitled, at no cost to you, to the provision of certain assistance. Please contact: in Orange County, ADA Coordinator, Human Resources, Orange County Courthouse, 425 N. Orange Avenue, Suite 510, Orlando, Florida, (407) 836-2303, fax: 407-836-2204; at least 7 days before your scheduled court appearance, or immediately upon receiving notification if the time before the scheduled court appearance is less than 7 days. If you are hearing or voice impaired, call 711 to reach the Telecommunications Relay Service. TIFFANY MOORE RUSSELL CLERK OF THE CIRCUIT COURT ORANGE COUNTY, FLORIDA August 23rd, 2021 /s/ Liz Yanira Gordian Olmo DEPUTY CLERK 425 North Orange Ave. Suite 350 Orlando, Florida 32801 September 2, 9, 2021 21-03144W

TIFFANY MOORE RUSSELL CLERK OF THE CIRCUIT COURT ORANGE COUNTY, FLORIDA August 23rd, 2021 /s/ Liz Yanira Gordian Olmo DEPUTY CLERK 425 North Orange Ave. Suite 350 Orlando, Florida 32801 September 2, 9, 2021 21-03143W

SECOND INSERTION

IN THE CIRCUIT COURT, IN AND FOR ORANGE COUNTY, FLORIDA. CASE NO.: 21-CA-006284-O #36 HOLIDAY INN CLUB VACATIONS INCORPORATED Plaintiff, vs. FAARUP ET.AL., Defendant(s). NOTICE OF ACTION Count V To: FABIAN EDNOLD JOHNSON and LYDIA PATRICE JOHNSON And all parties claiming interest by, through, under or against Defendant(s) FABIAN EDNOLD JOHNSON and LYDIA PATRICE JOHNSON and all parties having or claiming to have any right, title or interest in the property herein described. YOU ARE NOTIFIED that an action to foreclose a mortgage/claim of lien on the following described property : STANDARD Interest(s) in the Orange Lake Land Trust ("Trust") evidenced for administrative, assessment and ownership purposes by 50000 points, which Trust was created pursuant to and further described in that certain Trust Agreement for Orange Lake Land Trust dated December 15, 2017, executed by and among Chicago Title Time-share Land Trust, Inc., a Florida Corporation, as the trustee of the Trust, Holiday Inn Club Vacations Incorporated, a Delaware corporation, f/k/a Orange Lake Country Club, Inc., a Delaware corporation, and Orange Lake Trust Owners' Association, Inc., a Florida not-for-profit corporation, as such agreement may be amended and supplemented from time to time ("Trust Agreement"), a memorandum of which is recorded in Official Records Document Number: 20180061276, Public Records of

Orange County, Florida ("Memorandum of Trust")All of the terms, restrictions, covenants, conditions and provisions contained in the Declaration and any amendments thereto, are incorporated herein by reference with the same effect as though fully set forth herein. has been filed against you and you are required to serve a copy of your written defenses, if any, to it on Jerry E. Aron, Plaintiff's attorney, whose address is 2505 Metrocentre Blvd., Suite 301, West Palm Beach, Florida, 33407, within thirty (30) days after the first publication of this Notice, and file the original with the Clerk of this Court either before service on Plaintiff's attorney or immediately thereafter, otherwise a default will be entered against you for the relief demanded in the Complaint. If you are a person with disability who needs any accommodation in order to participate in a court proceeding or event, you are entitled, at no cost to you, to the provision of certain assistance. Please contact: in Orange County, ADA Coordinator, Human Resources, Orange County Courthouse, 425 N. Orange Avenue, Suite 510, Orlando, Florida, (407) 836-2303, fax: 407-836-2204; at least 7 days before your scheduled court appearance, or immediately upon receiving notification if the time before the scheduled court appearance is less than 7 days. If you are hearing or voice impaired, call 711 to reach the Telecommunications Relay Service. TIFFANY MOORE RUSSELL CLERK OF THE CIRCUIT COURT ORANGE COUNTY, FLORIDA 8/19/2021 /s/ Lisa Geib 425 North Orange Ave. Suite 350 Orlando, Florida 32801 September 2, 9, 2021 21-03134W

TIFFANY MOORE RUSSELL CLERK OF THE CIRCUIT COURT ORANGE COUNTY, FLORIDA August 23rd, 2021 /s/ Liz Yanira Gordian Olmo DEPUTY CLERK 425 North Orange Ave. Suite 350 Orlando, Florida 32801 September 2, 9, 2021 21-03134W

SECOND INSERTION

IN THE CIRCUIT COURT, IN AND FOR ORANGE COUNTY, FLORIDA. CASE NO.: 21-CA-004899-O #36 HOLIDAY INN CLUB VACATIONS INCORPORATED Plaintiff, vs. AGUILERA JOPIA ET.AL., Defendant(s). NOTICE OF ACTION Count IV To: RAFAEL BARROSO CABRAL and MARUSIA THOMAZ FERREIRA WILHELMS And all parties claiming interest by, through, under or against Defendant(s) RAFAEL BARROSO CABRAL and MARUSIA THOMAZ FERREIRA WILHELMS and all parties having or claiming to have any right, title or interest in the property herein described. YOU ARE NOTIFIED that an action to foreclose a mortgage/claim of lien on the following described property : STANDARD Interest(s) in the Orange Lake Land Trust ("Trust") evidenced for administrative, assessment and ownership purposes by 100000 points, which Trust was created pursuant to and further described in that certain Trust Agreement for Orange Lake Land Trust dated December 15, 2017, executed by

and among Chicago Title Time-share Land Trust, Inc., a Florida Corporation, as the trustee of the Trust, Holiday Inn Club Vacations Incorporated, a Delaware corporation, f/k/a Orange Lake Country Club, Inc., a Delaware corporation, and Orange Lake Trust Owners' Association, Inc., a Florida not-for-profit corporation, as such agreement may be amended and supplemented from time to time ("Trust Agreement"), a memorandum of which is recorded in Official Records Document Number: 20180061276, Public Records of Orange County, Florida ("Memorandum of Trust")All of the terms, restrictions, covenants, conditions and provisions contained in the Declaration and any amendments thereto, are incorporated herein by reference with the same effect as though fully set forth herein. has been filed against you and you are required to serve a copy of your written defenses, if any, to it on Jerry E. Aron, Plaintiff's attorney, whose address is 2505 Metrocentre Blvd., Suite 301, West Palm Beach, Florida, 33407, within thirty (30) days after

the first publication of this Notice, and file the original with the Clerk of this Court either before service on Plaintiff's attorney or immediately thereafter, otherwise a default will be entered against you for the relief demanded in the Complaint. If you are a person with disability who needs any accommodation in order to participate in a court proceeding or event, you are entitled, at no cost to you, to the provision of certain assistance. Please contact: in Orange County, ADA Coordinator, Human Resources, Orange County Courthouse, 425 N. Orange Avenue, Suite 510, Orlando, Florida, (407) 836-2303, fax: 407-836-2204; at least 7 days before your scheduled court appearance, or immediately upon receiving notification if the time before the scheduled court appearance is less than 7 days. If you are hearing or voice impaired, call 711 to reach the Telecommunications Relay Service. TIFFANY MOORE RUSSELL CLERK OF THE CIRCUIT COURT ORANGE COUNTY, FLORIDA /s/ yamina azizi deputy clerk 425 North Orange Ave. Suite 350 Orlando, Florida 32801 September 2, 9, 2021 21-03122W

TIFFANY MOORE RUSSELL CLERK OF THE CIRCUIT COURT ORANGE COUNTY, FLORIDA August 23rd, 2021 /s/ Liz Yanira Gordian Olmo DEPUTY CLERK 425 North Orange Ave. Suite 350 Orlando, Florida 32801 September 2, 9, 2021 21-03143W

SECOND INSERTION

IN THE CIRCUIT COURT, IN AND FOR ORANGE COUNTY, FLORIDA. CASE NO.: 21-CA-006285-O #36 HOLIDAY INN CLUB VACATIONS INCORPORATED Plaintiff, vs. MOHAMED ELSANGEDY ET.AL., Defendant(s). NOTICE OF ACTION Count III To: TIMOTHY CHRISTOPHER NEWMAN and ANN NEWMAN And all parties claiming interest by, through, under or against Defendant(s) TIMOTHY CHRISTOPHER NEWMAN and ANN NEWMAN and all parties having or claiming to have any right, title or interest in the property herein described. YOU ARE NOTIFIED that an action to foreclose a mortgage/claim of lien on the following described property : STANDARD Interest(s) in the Orange Lake Land Trust ("Trust") evidenced for administrative, assessment and ownership purposes by 50000 points, which Trust was created pursuant to and further described in that certain Trust Agreement for Orange Lake Land Trust dated December 15, 2017, executed by and among Chicago Title Time-share Land Trust, Inc., a Florida Corporation, as the trustee of the Trust, Holiday Inn Club Vacations Incorporated, a Delaware corporation, f/k/a Orange Lake Country Club, Inc., a Delaware corporation, and Orange Lake Trust Owners' Association, Inc., a Florida not-for-profit corporation, as such agreement may be amended and supplemented from time to time ("Trust Agreement"), a memorandum of which is recorded in Official Records Document Number: 20180061276, Public Records of

Orange County, Florida ("Memorandum of Trust")All of the terms, restrictions, covenants, conditions and provisions contained in the Declaration and any amendments thereto, are incorporated herein by reference with the same effect as though fully set forth herein. has been filed against you and you are required to serve a copy of your written defenses, if any, to it on Jerry E. Aron, Plaintiff's attorney, whose address is 2505 Metrocentre Blvd., Suite 301, West Palm Beach, Florida, 33407, within thirty (30) days after the first publication of this Notice, and file the original with the Clerk of this Court either before service on Plaintiff's attorney or immediately thereafter, otherwise a default will be entered against you for the relief demanded in the Complaint. If you are a person with disability who needs any accommodation in order to participate in a court proceeding or event, you are entitled, at no cost to you, to the provision of certain assistance. Please contact: in Orange County, ADA Coordinator, Human Resources, Orange County Courthouse, 425 N. Orange Avenue, Suite 510, Orlando, Florida, (407) 836-2303, fax: 407-836-2204; at least 7 days before your scheduled court appearance, or immediately upon receiving notification if the time before the scheduled court appearance is less than 7 days. If you are hearing or voice impaired, call 711 to reach the Telecommunications Relay Service. TIFFANY MOORE RUSSELL CLERK OF THE CIRCUIT COURT ORANGE COUNTY, FLORIDA August 23rd, 2021 /s/ Liz Yanira Gordian Olmo DEPUTY CLERK 425 North Orange Ave. Suite 350 Orlando, Florida 32801 September 2, 9, 2021 21-03142W

SECOND INSERTION

20180061276, Public Records of Orange County, Florida ("Memorandum of Trust")All of the terms, restrictions, covenants, conditions and provisions contained in the Declaration and any amendments thereto, are incorporated herein by reference with the same effect as though fully set forth herein. has been filed against you and you are required to serve a copy of your written defenses, if any, to it on Jerry E. Aron, Plaintiff's attorney, whose address is 2505 Metrocentre Blvd., Suite 301, West Palm Beach, Florida, 33407, within thirty (30) days after the first publication of this Notice, and file the original with the Clerk of this Court either before service on Plaintiff's attorney or immediately thereafter, otherwise a default will be entered against you for the relief demanded in the Complaint. If you are a person with disability who needs any accommodation in order to participate in a court proceeding or event, you are entitled, at no cost to you, to the provision of certain assistance. Please contact: in Orange County, ADA Coordinator, Human Resources, Orange County Courthouse, 425 N. Orange Avenue, Suite 510, Orlando, Florida, (407) 836-2303, fax: 407-836-2204; at least 7 days before your scheduled court appearance, or immediately upon receiving notification if the time before the scheduled court appearance is less than 7 days. If you are hearing or voice impaired, call 711 to reach the Telecommunications Relay Service. TIFFANY MOORE RUSSELL CLERK OF THE CIRCUIT COURT ORANGE COUNTY, FLORIDA 8/19/2021 /s/ Lisa Geib 425 North Orange Ave. Suite 350 Orlando, Florida 32801 September 2, 9, 2021 21-03130W

SECOND INSERTION

TIFFANY MOORE RUSSELL CLERK OF THE CIRCUIT COURT ORANGE COUNTY, FLORIDA August 23rd, 2021 /s/ Liz Yanira Gordian Olmo DEPUTY CLERK 425 North Orange Ave. Suite 350 Orlando, Florida 32801 September 2, 9, 2021 21-03130W

SECOND INSERTION

Orange County, Florida ("Memorandum of Trust")All of the terms, restrictions, covenants, conditions and provisions contained in the Declaration and any amendments thereto, are incorporated herein by reference with the same effect as though fully set forth herein. has been filed against you and you are required to serve a copy of your written defenses, if any, to it on Jerry E. Aron, Plaintiff's attorney, whose address is 2505 Metrocentre Blvd., Suite 301, West Palm Beach, Florida, 33407, within thirty (30) days after the first publication of this Notice, and file the original with the Clerk of this Court either before service on Plaintiff's attorney or immediately thereafter, otherwise a default will be entered against you for the relief demanded in the Complaint. If you are a person with disability who needs any accommodation in order to participate in a court proceeding or event, you are entitled, at no cost to you, to the provision of certain assistance. Please contact: in Orange County, ADA Coordinator, Human Resources, Orange County Courthouse, 425 N. Orange Avenue, Suite 510, Orlando, Florida, (407) 836-2303, fax: 407-836-2204; at least 7 days before your scheduled court appearance, or immediately upon receiving notification if the time before the scheduled court appearance is less than 7 days. If you are hearing or voice impaired, call 711 to reach the Telecommunications Relay Service. TIFFANY MOORE RUSSELL CLERK OF THE CIRCUIT COURT ORANGE COUNTY, FLORIDA /s/ yamina azizi deputy clerk 425 North Orange Ave. Suite 350 Orlando, Florida 32801 September 2, 9, 2021 21-03123W

ORANGE COUNTY SUBSEQUENT INSERTIONS

SECOND INSERTION

IN THE CIRCUIT COURT, IN AND FOR ORANGE COUNTY, FLORIDA. CASE NO.: 21-CA-005640-O #37 HOLIDAY INN CLUB VACATIONS INCORPORATED Plaintiff, vs. GARCIA RIVAS ET.AL., Defendant(s).

NOTICE OF ACTION Count XI To: JOHNNY LEE LUNDSTROM and BELINDA LOUISE ALLBRITTON And all parties claiming interest by, through, under or against Defendant(s) JOHNNY LEE LUNDSTROM and BELINDA LOUISE ALLBRITTON and all parties having or claiming to have any right, title or interest in the property herein described.

YOU ARE NOTIFIED that an action to foreclose a mortgage/claim of lien on the following described property : STANDARD Interest(s) in the Orange Lake Land Trust ("Trust") evidenced for administrative, assessment and ownership purposes by 100000 points, which Trust was created pursuant to and further described in that certain Trust Agreement for Orange Lake Land Trust dated December 15, 2017, executed by and among Chicago Title Time-

share Land Trust, Inc., a Florida Corporation, as the trustee of the Trust, Holiday Inn Club Vacations Incorporated, a Delaware corporation, f/k/a Orange Lake Country Club, Inc., a Delaware corporation, and Orange Lake Trust Owners' Association, Inc., a Florida not-for-profit corporation, as such agreement may be amended and supplemented from time to time ("Trust Agreement"), a memorandum of which is recorded in Official Records Document Number: 20180061276, Public Records of Orange County, Florida ("Memorandum of Trust")All of the terms, restrictions, covenants, conditions and provisions contained in the Declaration and any amendments thereto, are incorporated herein by reference with the same effect as though fully set forth herein.

has been filed against you and you are required to serve a copy of your written defenses, if any, to it on Jerry E. Aron, Plaintiff's attorney, whose address is 2505 Metrocentre Blvd., Suite 301, West Palm Beach, Florida, 33407, within thirty (30) days after the first publication of this Notice, and

file the original with the Clerk of this Court either before service on Plaintiff's attorney or immediately thereafter, otherwise a default will be entered against you for the relief demanded in the Complaint.

If you are a person with disability who needs any accommodation in order to participate in a court proceeding or event, you are entitled, at no cost to you, to the provision of certain assistance. Please contact: in Orange County, ADA Coordinator, Human Resources, Orange County Courthouse, 425 N. Orange Avenue, Suite 510, Orlando, Florida, (407) 836-2303, fax: 407-836-2204; at least 7 days before your scheduled court appearance, or immediately upon receiving notification if the time before the scheduled court appearance is less than 7 days. If you are hearing or voice impaired, call 711 to reach the Telecommunications Relay Service.

TIFFANY MOORE RUSSELL CLERK OF THE CIRCUIT COURT ORANGE COUNTY, FLORIDA August 23rd, 2021 /s/ Liz Yanira Gordian Olmo DEPUTY CLERK 425 North Orange Ave. Suite 350 Orlando, Florida 32801 September 2, 9, 2021 21-03166W

IN THE CIRCUIT COURT, IN AND FOR ORANGE COUNTY, FLORIDA. CASE NO.: 21-CA-004899-O #36 HOLIDAY INN CLUB VACATIONS INCORPORATED Plaintiff, vs. AGUILERA JOPIA ET.AL., Defendant(s).

NOTICE OF ACTION Count I To: TAMARA THAIS AGUILERA JOPIA and MARIA BERNARDA JOPIA CONTRERAS And all parties claiming interest by, through, under or against Defendant(s) TAMARA THAIS AGUILERA JOPIA and MARIA BERNARDA JOPIA CONTRERAS and all parties having or claiming to have any right, title or interest in the property herein described.

YOU ARE NOTIFIED that an action to foreclose a mortgage/claim of lien on the following described property : STANDARD Interest(s) in the Orange Lake Land Trust ("Trust") evidenced for administrative, assessment and ownership purposes by 110000 points, which Trust was created pursuant to and further described in that certain Trust Agreement for Orange Lake Land Trust dated December 15, 2017, executed by

SECOND INSERTION

and among Chicago Title Time-share Land Trust, Inc., a Florida Corporation, as the trustee of the Trust, Holiday Inn Club Vacations Incorporated, a Delaware corporation, f/k/a Orange Lake Country Club, Inc., a Delaware corporation, and Orange Lake Trust Owners' Association, Inc., a Florida not-for-profit corporation, as such agreement may be amended and supplemented from time to time ("Trust Agreement"), a memorandum of which is recorded in Official Records Document Number: 20180061276, Public Records of Orange County, Florida ("Memorandum of Trust")All of the terms, restrictions, covenants, conditions and provisions contained in the Declaration and any amendments thereto, are incorporated herein by reference with the same effect as though fully set forth herein.

has been filed against you and you are required to serve a copy of your written defenses, if any, to it on Jerry E. Aron, Plaintiff's attorney, whose address is 2505 Metrocentre Blvd., Suite 301, West Palm Beach, Florida, 33407, within thirty (30) days after

the first publication of this Notice, and file the original with the Clerk of this Court either before service on Plaintiff's attorney or immediately thereafter, otherwise a default will be entered against you for the relief demanded in the Complaint.

If you are a person with disability who needs any accommodation in order to participate in a court proceeding or event, you are entitled, at no cost to you, to the provision of certain assistance. Please contact: in Orange County, ADA Coordinator, Human Resources, Orange County Courthouse, 425 N. Orange Avenue, Suite 510, Orlando, Florida, (407) 836-2303, fax: 407-836-2204; at least 7 days before your scheduled court appearance, or immediately upon receiving notification if the time before the scheduled court appearance is less than 7 days. If you are hearing or voice impaired, call 711 to reach the Telecommunications Relay Service.

TIFFANY MOORE RUSSELL CLERK OF THE CIRCUIT COURT ORANGE COUNTY, FLORIDA /s/ yamina azizi deputy clerk 425 North Orange Ave. Suite 350 Orlando, Florida 32801 September 2, 9, 2021 21-03120W

SECOND INSERTION

IN THE CIRCUIT COURT, IN AND FOR ORANGE COUNTY, FLORIDA. CASE NO.: 21-CA-005647-O #37 HOLIDAY INN CLUB VACATIONS INCORPORATED Plaintiff, vs. SMALL ET.AL., Defendant(s).

NOTICE OF ACTION Count III To: JENNIFER ELAINE SCHNEIDER And all parties claiming interest by, through, under or against Defendant(s) JENNIFER ELAINE SCHNEIDER and all parties having or claiming to have any right, title or interest in the property herein described.

YOU ARE NOTIFIED that an action to foreclose a mortgage/claim of lien on the following described property : STANDARD Interest(s) in the Orange Lake Land Trust ("Trust") evidenced for administrative, assessment and ownership purposes by 50000 points, which Trust was created pursuant to and further described in that certain Trust Agreement for Orange Lake Land Trust dated December 15, 2017, executed by and among Chicago Title Time-

Orange County, Florida ("Memorandum of Trust")All of the terms, restrictions, covenants, conditions and provisions contained in the Declaration and any amendments thereto, are incorporated herein by reference with the same effect as though fully set forth herein.

has been filed against you and you are required to serve a copy of your written defenses, if any, to it on Jerry E. Aron, Plaintiff's attorney, whose address is 2505 Metrocentre Blvd., Suite 301, West Palm Beach, Florida, 33407, within thirty (30) days after the first publication of this Notice, and file the original with the Clerk of this Court either before service on Plaintiff's attorney or immediately thereafter, otherwise a default will be entered against you for the relief demanded in the Complaint.

If you are a person with disability who needs any accommodation in order to participate in a court proceeding or event, you are entitled, at no cost to you, to the provision of certain assistance. Please contact: in Orange County, ADA Coordinator, Human Resources, Orange County Courthouse, 425 N. Orange Avenue, Suite 510, Orlando, Florida, (407) 836-2303, fax: 407-836-2204; at least 7 days before your scheduled court appearance, or immediately upon receiving notification if the time before the scheduled court appearance is less than 7 days. If you are hearing or voice impaired, call 711 to reach the Telecommunications Relay Service.

TIFFANY MOORE RUSSELL CLERK OF THE CIRCUIT COURT ORANGE COUNTY, FLORIDA /s/ Stan Green, Deputy Clerk 425 North Orange Ave. Suite 350 Orlando, Florida 32801 September 2, 9, 2021 21-03169W

IN THE CIRCUIT COURT, IN AND FOR ORANGE COUNTY, FLORIDA. CASE NO.: 21-CA-006290-O #39 HOLIDAY INN CLUB VACATIONS INCORPORATED Plaintiff, vs. MARCELIN ET.AL., Defendant(s).

NOTICE OF ACTION Count VIII To: LAWRENCE W. MCGIVNEY AND ANY AND ALL UNKNOWN HEIRS, DEWISEES AND OTHER CLAIMANTS OF LAWRENCE W. MCGIVNEY And all parties claiming interest by, through, under or against Defendant(s) LAWRENCE W. MCGIVNEY AND ANY AND ALL UNKNOWN HEIRS, DEWISEES AND OTHER CLAIMANTS OF LAWRENCE W. MCGIVNEY and all parties having or claiming to have any right, title or interest in the property herein described:

YOU ARE NOTIFIED that an action to foreclose a mortgage/claim of lien on the following described property in Orange County, Florida: WEEK/UNIT: 52/53/003546 of Orange Lake Country Club Villas III, a Condominium, together with an undivided interest in the common elements appurtenant thereto, according to the Declaration of Condominium thereof recorded in Official Records Book 5914, Page 1965, in the Public Records of Orange County, Florida, and all amendments thereto; the plat of which is recorded in Condominium Book 28, page 84-92 until 12:00 noon on the first Saturday 2071, at which date said estate shall terminate; TOGETHER with a

remainder over in fee simple absolute as tenant in common with the other owners of all the unit weeks in the above described Condominium in the percentage interest established in the Declaration of Condominium.

has been filed against you and you are required to serve a copy of your written defenses, if any, to it on Jerry E. Aron, Plaintiff's attorney, whose address is 2505 Metrocentre Blvd., Suite 301, West Palm Beach, Florida, 33407, within thirty (30) days after the first publication of this Notice, and file the original with the Clerk of this Court either before service on Plaintiff's attorney or immediately thereafter, otherwise a default will be entered against you for the relief demanded in the Complaint.

If you are a person with disability who needs any accommodation in order to participate in a court proceeding or event, you are entitled, at no cost to you, to the provision of certain assistance. Please contact: in Orange County, ADA Coordinator, Human Resources, Orange County Courthouse, 425 N. Orange Avenue, Suite 510, Orlando, Florida, (407) 836-2303, fax: 407-836-2204; at least 7 days before your scheduled court appearance, or immediately upon receiving notification if the time before the scheduled court appearance is less than 7 days. If you are hearing or voice impaired, call 711 to reach the Telecommunications Relay Service.

(10/14/2021) TIFFANY MOORE RUSSELL CLERK OF THE CIRCUIT COURT ORANGE COUNTY, FLORIDA /s/ Nancy Garcia, 8/19/2021 Deputy Clerk 425 North Orange Ave. Suite 350 Orlando, Florida 32801 September 2, 9, 2021 21-03185W

IN THE CIRCUIT COURT, IN AND FOR ORANGE COUNTY, FLORIDA. CASE NO.: 21-CA-006290-O #39 HOLIDAY INN CLUB VACATIONS INCORPORATED Plaintiff, vs. MARCELIN ET.AL., Defendant(s).

NOTICE OF ACTION Count IV To: TERESA MARIE JAMES and JEFFERY GLENN JAMES AND ANY AND ALL UNKNOWN HEIRS, DEWISEES AND OTHER CLAIMANTS OF JEFFERY GLENN JAMES

And all parties claiming interest by, through, under or against Defendant(s) TERESA MARIE JAMES and JEFFERY GLENN JAMES AND ANY AND ALL UNKNOWN HEIRS, DEWISEES AND OTHER CLAIMANTS OF JEFFERY GLENN JAMES and all parties having or claiming to have any right, title or interest in the property herein described:

YOU ARE NOTIFIED that an action to foreclose a mortgage/claim of lien on the following described property in Orange County, Florida:

WEEK/UNIT: 48 ODD/87826 of Orange Lake Country Club Villas III, a Condominium, together with an undivided interest in the common elements appurtenant thereto, according to the Declaration of Condominium thereof recorded in Official Records Book 5914, Page 1965, in the Public Records of Orange County, Florida, and all amendments thereto; the plat of which is recorded in Condominium Book 28, page 84-92 until 12:00 noon on the first Saturday 2071, at which date said estate shall terminate; TOGETHER with a

remainder over in fee simple absolute as tenant in common with the other owners of all the unit weeks in the above described Condominium in the percentage interest established in the Declaration of Condominium.

has been filed against you and you are required to serve a copy of your written defenses, if any, to it on Jerry E. Aron, Plaintiff's attorney, whose address is 2505 Metrocentre Blvd., Suite 301, West Palm Beach, Florida, 33407, within thirty (30) days after the first publication of this Notice, and file the original with the Clerk of this Court either before service on Plaintiff's attorney or immediately thereafter, otherwise a default will be entered against you for the relief demanded in the Complaint.

If you are a person with disability who needs any accommodation in order to participate in a court proceeding or event, you are entitled, at no cost to you, to the provision of certain assistance. Please contact: in Orange County, ADA Coordinator, Human Resources, Orange County Courthouse, 425 N. Orange Avenue, Suite 510, Orlando, Florida, (407) 836-2303, fax: 407-836-2204; at least 7 days before your scheduled court appearance, or immediately upon receiving notification if the time before the scheduled court appearance is less than 7 days. If you are hearing or voice impaired, call 711 to reach the Telecommunications Relay Service.

(10/14/2021) TIFFANY MOORE RUSSELL CLERK OF THE CIRCUIT COURT ORANGE COUNTY, FLORIDA /s/ Nancy Garcia, 8/19/2021 Deputy Clerk 425 North Orange Ave. Suite 350 Orlando, Florida 32801 September 2, 9, 2021 21-03182W

SECOND INSERTION

IN THE CIRCUIT COURT, IN AND FOR ORANGE COUNTY, FLORIDA. CASE NO.: 21-CA-005640-O #37 HOLIDAY INN CLUB VACATIONS INCORPORATED Plaintiff, vs. GARCIA RIVAS ET.AL., Defendant(s).

NOTICE OF ACTION Count X To: ROBERT LENNOX and LESLEY WARDROP And all parties claiming interest by, through, under or against Defendant(s) ROBERT LENNOX and LESLEY WARDROP and all parties having or claiming to have any right, title or interest in the property herein described.

YOU ARE NOTIFIED that an action to foreclose a mortgage/claim of lien on the following described property :

STANDARD Interest(s) in the Orange Lake Land Trust ("Trust") evidenced for administrative, assessment and ownership purposes by 100000 points, which Trust was created pursuant to and further described in that certain Trust Agreement for Orange Lake Land Trust dated December 15, 2017, executed by and among Chicago Title Time-share Land Trust, Inc., a Florida Corporation, as the trustee of the Trust, Holiday Inn Club Vacations Incorporated, a Delaware corporation, f/k/a Orange Lake Country Club, Inc., a Delaware corporation, and Orange Lake Trust Owners' Association, Inc., a Florida not-for-profit corporation, as such agreement may be amended and supplemented from time to time ("Trust Agreement"), a memorandum of which is recorded in Official Records Document Number: 20180061276, Public Records of Orange County, Florida ("Mem-

orandum of Trust")All of the terms, restrictions, covenants, conditions and provisions contained in the Declaration and any amendments thereto, are incorporated herein by reference with the same effect as though fully set forth herein.

has been filed against you and you are required to serve a copy of your written defenses, if any, to it on Jerry E. Aron, Plaintiff's attorney, whose address is 2505 Metrocentre Blvd., Suite 301, West Palm Beach, Florida, 33407, within thirty (30) days after the first publication of this Notice, and file the original with the Clerk of this Court either before service on Plaintiff's attorney or immediately thereafter, otherwise a default will be entered against you for the relief demanded in the Complaint.

If you are a person with disability who needs any accommodation in order to participate in a court proceeding or event, you are entitled, at no cost to you, to the provision of certain assistance. Please contact: in Orange County, ADA Coordinator, Human Resources, Orange County Courthouse, 425 N. Orange Avenue, Suite 510, Orlando, Florida, (407) 836-2303, fax: 407-836-2204; at least 7 days before your scheduled court appearance, or immediately upon receiving notification if the time before the scheduled court appearance is less than 7 days. If you are hearing or voice impaired, call 711 to reach the Telecommunications Relay Service.

TIFFANY MOORE RUSSELL CLERK OF THE CIRCUIT COURT ORANGE COUNTY, FLORIDA August 23rd, 2021 /s/ Liz Yanira Gordian Olmo DEPUTY CLERK 425 North Orange Ave. Suite 350 Orlando, Florida 32801 September 2, 9, 2021 21-03165W

IN THE CIRCUIT COURT, IN AND FOR ORANGE COUNTY, FLORIDA. CASE NO.: 21-CA-005640-O #37 HOLIDAY INN CLUB VACATIONS INCORPORATED Plaintiff, vs. GARCIA RIVAS ET.AL., Defendant(s).

NOTICE OF ACTION Count VII To: DANE BENJAMIN HONE and MARLO LYNN HONE And all parties claiming interest by, through, under or against Defendant(s) DANE BENJAMIN HONE and MARLO LYNN HONE and all parties having or claiming to have any right, title or interest in the property herein described.

YOU ARE NOTIFIED that an action to foreclose a mortgage/claim of lien on the following described property :

STANDARD Interest(s) in the Orange Lake Land Trust ("Trust") evidenced for administrative, assessment and ownership purposes by 50000 points, which Trust was created pursuant to and further described in that certain Trust Agreement for Orange Lake Land Trust dated December 15, 2017, executed by and among Chicago Title Time-share Land Trust, Inc., a Florida Corporation, as the trustee of the Trust, Holiday Inn Club Vacations Incorporated, a Delaware corporation, f/k/a Orange Lake Country Club, Inc., a Delaware corporation, and Orange Lake Trust Owners' Association, Inc., a Florida not-for-profit corporation, as such agreement may be amended and supplemented from time to time ("Trust Agreement"), a memorandum of which is recorded in Official Records Document Number: 20180061276, Public Records of Orange County, Florida ("Mem-

orandum of Trust")All of the terms, restrictions, covenants, conditions and provisions contained in the Declaration and any amendments thereto, are incorporated herein by reference with the same effect as though fully set forth herein.

has been filed against you and you are required to serve a copy of your written defenses, if any, to it on Jerry E. Aron, Plaintiff's attorney, whose address is 2505 Metrocentre Blvd., Suite 301, West Palm Beach, Florida, 33407, within thirty (30) days after the first publication of this Notice, and file the original with the Clerk of this Court either before service on Plaintiff's attorney or immediately thereafter, otherwise a default will be entered against you for the relief demanded in the Complaint.

If you are a person with disability who needs any accommodation in order to participate in a court proceeding or event, you are entitled, at no cost to you, to the provision of certain assistance. Please contact: in Orange County, ADA Coordinator, Human Resources, Orange County Courthouse, 425 N. Orange Avenue, Suite 510, Orlando, Florida, (407) 836-2303, fax: 407-836-2204; at least 7 days before your scheduled court appearance, or immediately upon receiving notification if the time before the scheduled court appearance is less than 7 days. If you are hearing or voice impaired, call 711 to reach the Telecommunications Relay Service.

TIFFANY MOORE RUSSELL CLERK OF THE CIRCUIT COURT ORANGE COUNTY, FLORIDA August 23rd, 2021 /s/ Liz Yanira Gordian Olmo DEPUTY CLERK 425 North Orange Ave. Suite 350 Orlando, Florida 32801 September 2, 9, 2021 21-03162W

IN THE CIRCUIT COURT, IN AND FOR ORANGE COUNTY, FLORIDA. CASE NO.: 21-CA-005640-O #37 HOLIDAY INN CLUB VACATIONS INCORPORATED Plaintiff, vs. GARCIA RIVAS ET.AL., Defendant(s).

NOTICE OF ACTION Count II To: KAMBO GITHU A/K/A G. KAMBO And all parties claiming interest by, through, under or against Defendant(s) KAMBO GITHU A/K/A G. KAMBO and all parties having or claiming to have any right, title or interest in the property herein described.

YOU ARE NOTIFIED that an action to foreclose a mortgage/claim of lien on the following described property :

STANDARD Interest(s) in the Orange Lake Land Trust ("Trust") evidenced for administrative, assessment and ownership purposes by 100000 points, which Trust was created pursuant to and further described in that certain Trust Agreement for Orange Lake Land Trust dated December 15, 2017, executed by and among Chicago Title Time-share Land Trust, Inc., a Florida Corporation, as the trustee of the Trust, Holiday Inn Club Vacations Incorporated, a Delaware corporation, f/k/a Orange Lake Country Club, Inc., a Delaware corporation, and Orange Lake Trust Owners' Association, Inc., a Florida not-for-profit corporation, as such agreement may be amended and supplemented from time to time ("Trust Agreement"), a memorandum of which is recorded in Official Records Document Number: 20180061276, Public Records of Orange County, Florida ("Mem-

orandum of Trust")All of the terms, restrictions, covenants, conditions and provisions contained in the Declaration and any amendments thereto, are incorporated herein by reference with the same effect as though fully set forth herein.

has been filed against you and you are required to serve a copy of your written defenses, if any, to it on Jerry E. Aron, Plaintiff's attorney, whose address is 2505 Metrocentre Blvd., Suite 301, West Palm Beach, Florida, 33407, within thirty (30) days after the first publication of this Notice, and file the original with the Clerk of this Court either before service on Plaintiff's attorney or immediately thereafter, otherwise a default will be entered against you for the relief demanded in the Complaint.

If you are a person with disability who needs any accommodation in order to participate in a court proceeding or event, you are entitled, at no cost to you, to the provision of certain assistance. Please contact: in Orange County, ADA Coordinator, Human Resources, Orange County Courthouse, 425 N. Orange Avenue, Suite 510, Orlando, Florida, (407) 836-2303, fax: 407-836-2204; at least 7 days before your scheduled court appearance, or immediately upon receiving notification if the time before the scheduled court appearance is less than 7 days. If you are hearing or voice impaired, call 711 to reach the Telecommunications Relay Service.

TIFFANY MOORE RUSSELL CLERK OF THE CIRCUIT COURT ORANGE COUNTY, FLORIDA August 23rd, 2021 /s/ Liz Yanira Gordian Olmo DEPUTY CLERK 425 North Orange Ave. Suite 350 Orlando, Florida 32801 September 2, 9, 2021 21-03159W















# ORANGE COUNTY

## SUBSEQUENT INSERTIONS

**SECOND INSERTION**

IN THE CIRCUIT COURT, IN AND FOR ORANGE COUNTY, FLORIDA.  
**CASE NO.: 21-CA-005950-O #39 HOLIDAY INN CLUB VACATIONS INCORPORATED**  
**Plaintiff, vs.**  
**NOGUE ET.AL.,**  
**Defendant(s).**

NOTICE OF ACTION  
 Count I

To: CHANTAL NOGUE and DENIS ROY

And all parties claiming interest by, through, under or against Defendant(s) CHANTAL NOGUE and DENIS ROY and all parties having or claiming to have any right, title or interest in the property herein described:

YOU ARE NOTIFIED that an action to foreclose a mortgage/claim of lien on the following described property in Orange County, Florida:

WEEK/UNIT:  
 20/002586  
 of Orange Lake Country Club Villas II, a Condominium, together with an undivided interest in the common elements appurtenant thereto, according to the Declaration of Condominium thereof recorded in Official Records Book 4846, Page 1619, in the Public Records of Orange County, Florida, and all amendments thereto; the plat of which is recorded in Condominium Book 22, page 132-146 until 12:00 noon on the first Saturday 2061, at which date said estate shall terminate; TOGETHER with a remainder over in fee simple absolute as tenant in common with the other owners of all the unit weeks in the above de-

scribed Condominium in the percentage interest established in the Declaration of Condominium.

has been filed against you and you are required to serve a copy of your written defenses, if any, to it on Jerry E. Aron, Plaintiff's attorney, whose address is 2505 Metrocentre Blvd., Suite 301, West Palm Beach, Florida, 33407, within thirty (30) days after the first publication of this Notice, and file the original with the Clerk of this Court either before service on Plaintiff's attorney or immediately thereafter, otherwise a default will be entered against you for the relief demanded in the Complaint.

If you are a person with disability who needs any accommodation in order to participate in a court proceeding or event, you are entitled, at no cost to you, to the provision of certain assistance. Please contact: in Orange County, ADA Coordinator, Human Resources, Orange County Courthouse, 425 N. Orange Avenue, Suite 510, Orlando, Florida, (407) 836-2303, fax: 407-836-2204; at least 7 days before your scheduled court appearance, or immediately upon receiving notification if the time before the scheduled court appearance is less than 7 days. If you are hearing or voice impaired, call 711 to reach the Telecommunications Relay Service.

August 24th, 2021  
 TIFFANY MOORE RUSSELL  
 CLERK OF THE CIRCUIT COURT  
 ORANGE COUNTY, FLORIDA  
 /s/ Liz Yanira Gordian Olmo  
 Deputy Clerk  
 425 North Orange Ave.  
 Suite 350  
 Orlando, Florida 32801  
 September 2, 9, 2021 21-03188W

**SECOND INSERTION**

IN THE CIRCUIT COURT, IN AND FOR ORANGE COUNTY, FLORIDA.  
**CASE NO.: 21-CA-006290-O #39 HOLIDAY INN CLUB VACATIONS INCORPORATED**  
**Plaintiff, vs.**  
**MARCELIN ET.AL.,**  
**Defendant(s).**

NOTICE OF ACTION  
 Count X

To: MICHAEL PANTAS and MARIA VICTORIA PANTAS

And all parties claiming interest by, through, under or against Defendant(s) MICHAEL PANTAS and MARIA VICTORIA PANTAS and all parties having or claiming to have any right, title or interest in the property herein described:

YOU ARE NOTIFIED that an action to foreclose a mortgage/claim of lien on the following described property in Orange County, Florida:

WEEK/UNIT:  
 18 ODD/3723  
 of Orange Lake Country Club Villas III, a Condominium, together with an undivided interest in the common elements appurtenant thereto, according to the Declaration of Condominium thereof recorded in Official Records Book 5914, Page 1965, in the Public Records of Orange County, Florida, and all amendments thereto; the plat of which is recorded in Condominium Book 28, page 84-92 until 12:00 noon on the first Saturday 2071, at which date said estate shall terminate; TOGETHER with a remainder over in fee simple absolute as tenant in common with the other owners of all the unit

weeks in the above described Condominium in the percentage interest established in the Declaration of Condominium.

has been filed against you and you are required to serve a copy of your written defenses, if any, to it on Jerry E. Aron, Plaintiff's attorney, whose address is 2505 Metrocentre Blvd., Suite 301, West Palm Beach, Florida, 33407, within thirty (30) days after the first publication of this Notice, and file the original with the Clerk of this Court either before service on Plaintiff's attorney or immediately thereafter, otherwise a default will be entered against you for the relief demanded in the Complaint.

If you are a person with disability who needs any accommodation in order to participate in a court proceeding or event, you are entitled, at no cost to you, to the provision of certain assistance. Please contact: in Orange County, ADA Coordinator, Human Resources, Orange County Courthouse, 425 N. Orange Avenue, Suite 510, Orlando, Florida, (407) 836-2303, fax: 407-836-2204; at least 7 days before your scheduled court appearance, or immediately upon receiving notification if the time before the scheduled court appearance is less than 7 days. If you are hearing or voice impaired, call 711 to reach the Telecommunications Relay Service.

(10/14/2021)  
 TIFFANY MOORE RUSSELL  
 CLERK OF THE CIRCUIT COURT  
 ORANGE COUNTY, FLORIDA  
 /s/ Nancy Garcia, 8/19/2021  
 Deputy Clerk  
 425 North Orange Ave. Suite 350  
 Orlando, Florida 32801  
 September 2, 9, 2021 21-03187W

**SECOND INSERTION**

IN THE CIRCUIT COURT, IN AND FOR ORANGE COUNTY, FLORIDA.  
**CASE NO.: 21-CA-006290-O #39 HOLIDAY INN CLUB VACATIONS INCORPORATED**  
**Plaintiff, vs.**  
**MARCELIN ET.AL.,**  
**Defendant(s).**

NOTICE OF ACTION  
 Count IX

To: JUAN CARLOS MORALES OCA-MPO

And all parties claiming interest by, through, under or against Defendant(s) JUAN CARLOS MORALES OCA-MPO and all parties having or claiming to have any right, title or interest in the property herein described:

YOU ARE NOTIFIED that an action to foreclose a mortgage/claim of lien on the following described property in Orange County, Florida:

WEEK/UNIT:  
 39/087721  
 of Orange Lake Country Club Villas III, a Condominium, together with an undivided interest in the common elements appurtenant thereto, according to the Declaration of Condominium thereof recorded in Official Records Book 5914, Page 1965, in the Public Records of Orange County, Florida, and all amendments thereto; the plat of which is recorded in Condominium Book 28, page 84-92 until 12:00 noon on the first Saturday 2071, at which date said estate shall terminate; TOGETHER with a remainder over in fee simple absolute as tenant in common with the other owners of all the unit

weeks in the above described Condominium in the percentage interest established in the Declaration of Condominium.

has been filed against you and you are required to serve a copy of your written defenses, if any, to it on Jerry E. Aron, Plaintiff's attorney, whose address is 2505 Metrocentre Blvd., Suite 301, West Palm Beach, Florida, 33407, within thirty (30) days after the first publication of this Notice, and file the original with the Clerk of this Court either before service on Plaintiff's attorney or immediately thereafter, otherwise a default will be entered against you for the relief demanded in the Complaint.

If you are a person with disability who needs any accommodation in order to participate in a court proceeding or event, you are entitled, at no cost to you, to the provision of certain assistance. Please contact: in Orange County, ADA Coordinator, Human Resources, Orange County Courthouse, 425 N. Orange Avenue, Suite 510, Orlando, Florida, (407) 836-2303, fax: 407-836-2204; at least 7 days before your scheduled court appearance, or immediately upon receiving notification if the time before the scheduled court appearance is less than 7 days. If you are hearing or voice impaired, call 711 to reach the Telecommunications Relay Service.

(10/14/2021)  
 TIFFANY MOORE RUSSELL  
 CLERK OF THE CIRCUIT COURT  
 ORANGE COUNTY, FLORIDA  
 /s/ Nancy Garcia, 8/19/2021  
 Deputy Clerk  
 425 North Orange Ave. Suite 350  
 Orlando, Florida 32801  
 September 2, 9, 2021 21-03186W

**SECOND INSERTION**

IN THE CIRCUIT COURT, IN AND FOR ORANGE COUNTY, FLORIDA.  
**CASE NO.: 21-CA-006286-O #35 HOLIDAY INN CLUB VACATIONS INCORPORATED**  
**Plaintiff, vs.**  
**BRUNET DE FIGUEIREDO ET.AL.,**  
**Defendant(s).**

NOTICE OF ACTION  
 Count V

To: GLAUCO DAMASCENO SILVA and MARIA DE FATIMA RIBEIRO DAMASCENO SILVA

And all parties claiming interest by, through, under or against Defendant(s) GLAUCO DAMASCENO SILVA and MARIA DE FATIMA RIBEIRO DAMASCENO SILVA and all parties having or claiming to have any right, title or interest in the property herein described:

YOU ARE NOTIFIED that an action to foreclose a mortgage/claim of lien on the following described property in Orange County, Florida:

WEEK/UNIT:  
 37 EVEN/088026  
 of Orange Lake Country Club Villas III, a Condominium, together with an undivided interest in the common elements appurtenant thereto, according to the Declaration of Condominium thereof recorded in Official Records Book 5914, Page 1965, in the Public Records of Orange County, Florida, and all amendments thereto; the plat of which is recorded in Condominium Book 28, page 84-92 until 12:00 noon on the first Saturday 2071, at which date said estate shall terminate; TOGETHER with a remainder over in fee simple absolute as tenant in common with

the other owners of all the unit weeks in the above described Condominium in the percentage interest established in the Declaration of Condominium.

has been filed against you and you are required to serve a copy of your written defenses, if any, to it on Jerry E. Aron, Plaintiff's attorney, whose address is 2505 Metrocentre Blvd., Suite 301, West Palm Beach, Florida, 33407, within thirty (30) days after the first publication of this Notice, and file the original with the Clerk of this Court either before service on Plaintiff's attorney or immediately thereafter, otherwise a default will be entered against you for the relief demanded in the Complaint.

If you are a person with disability who needs any accommodation in order to participate in a court proceeding or event, you are entitled, at no cost to you, to the provision of certain assistance. Please contact: in Orange County, ADA Coordinator, Human Resources, Orange County Courthouse, 425 N. Orange Avenue, Suite 510, Orlando, Florida, (407) 836-2303, fax: 407-836-2204; at least 7 days before your scheduled court appearance, or immediately upon receiving notification if the time before the scheduled court appearance is less than 7 days. If you are hearing or voice impaired, call 711 to reach the Telecommunications Relay Service.

August 25th, 2021  
 TIFFANY MOORE RUSSELL  
 CLERK OF THE CIRCUIT COURT  
 ORANGE COUNTY, FLORIDA  
 /s/ Liz Yanira Gordian Olmo  
 Deputy Clerk  
 425 North Orange Ave.  
 Suite 350  
 Orlando, Florida 32801  
 September 2, 9, 2021 21-03098W

**SECOND INSERTION**

IN THE CIRCUIT COURT, IN AND FOR ORANGE COUNTY, FLORIDA.  
**CASE NO.: 21-CA-006286-O #35 HOLIDAY INN CLUB VACATIONS INCORPORATED**  
**Plaintiff, vs.**  
**BRUNET DE FIGUEIREDO ET.AL.,**  
**Defendant(s).**

NOTICE OF ACTION  
 Count IV

To: WALTER ROBERTO CRUZ VILLEDA and MONICA LORENA CORONADO ESQUIVEL

And all parties claiming interest by, through, under or against Defendant(s) WALTER ROBERTO CRUZ VILLEDA and MONICA LORENA CORONADO ESQUIVEL and all parties having or claiming to have any right, title or interest in the property herein described:

YOU ARE NOTIFIED that an action to foreclose a mortgage/claim of lien on the following described property in Orange County, Florida:

WEEK/UNIT:  
 43 ODD/087812  
 of Orange Lake Country Club Villas III, a Condominium, together with an undivided interest in the common elements appurtenant thereto, according to the Declaration of Condominium thereof recorded in Official Records Book 5914, Page 1965, in the Public Records of Orange County, Florida, and all amendments thereto; the plat of which is recorded in Condominium Book 28, page 84-92 until 12:00 noon on the first Saturday 2071, at which date said estate shall terminate; TOGETHER with a remainder over in fee simple absolute as tenant in common with

the other owners of all the unit weeks in the above described Condominium in the percentage interest established in the Declaration of Condominium.

has been filed against you and you are required to serve a copy of your written defenses, if any, to it on Jerry E. Aron, Plaintiff's attorney, whose address is 2505 Metrocentre Blvd., Suite 301, West Palm Beach, Florida, 33407, within thirty (30) days after the first publication of this Notice, and file the original with the Clerk of this Court either before service on Plaintiff's attorney or immediately thereafter, otherwise a default will be entered against you for the relief demanded in the Complaint.

If you are a person with disability who needs any accommodation in order to participate in a court proceeding or event, you are entitled, at no cost to you, to the provision of certain assistance. Please contact: in Orange County, ADA Coordinator, Human Resources, Orange County Courthouse, 425 N. Orange Avenue, Suite 510, Orlando, Florida, (407) 836-2303, fax: 407-836-2204; at least 7 days before your scheduled court appearance, or immediately upon receiving notification if the time before the scheduled court appearance is less than 7 days. If you are hearing or voice impaired, call 711 to reach the Telecommunications Relay Service.

August 25th, 2021  
 TIFFANY MOORE RUSSELL  
 CLERK OF THE CIRCUIT COURT  
 ORANGE COUNTY, FLORIDA  
 /s/ Liz Yanira Gordian Olmo  
 Deputy Clerk  
 425 North Orange Ave.  
 Suite 350  
 Orlando, Florida 32801  
 September 2, 9, 2021 21-03097W

**SECOND INSERTION**

IN THE CIRCUIT COURT, IN AND FOR ORANGE COUNTY, FLORIDA.  
**CASE NO.: 21-CA-005950-O #39 HOLIDAY INN CLUB VACATIONS INCORPORATED**  
**Plaintiff, vs.**  
**NOGUE ET.AL.,**  
**Defendant(s).**

NOTICE OF ACTION  
 Count III

To: VANESSA MARIA QUINTANA MOSCOA

And all parties claiming interest by, through, under or against Defendant(s) VANESSA MARIA QUINTANA MOSCOA and all parties having or claiming to have any right, title or interest in the property herein described:

YOU ARE NOTIFIED that an action to foreclose a mortgage/claim of lien on the following described property in Orange County, Florida:

WEEK/UNIT:  
 18/002538  
 of Orange Lake Country Club Villas II, a Condominium, together with an undivided interest in the common elements appurtenant thereto, according to the Declaration of Condominium thereof recorded in Official Records Book 4846, Page 1619, in the Public Records of Orange County, Florida, and all amendments thereto; the plat of which is recorded in Condominium Book 22, page 132-146 until 12:00 noon on the first Saturday 2061, at which date said estate shall terminate; TOGETHER with a remainder over in fee simple absolute as tenant in common with the other owners of all the unit weeks in the

above described Condominium in the percentage interest established in the Declaration of Condominium.

has been filed against you and you are required to serve a copy of your written defenses, if any, to it on Jerry E. Aron, Plaintiff's attorney, whose address is 2505 Metrocentre Blvd., Suite 301, West Palm Beach, Florida, 33407, within thirty (30) days after the first publication of this Notice, and file the original with the Clerk of this Court either before service on Plaintiff's attorney or immediately thereafter, otherwise a default will be entered against you for the relief demanded in the Complaint.

If you are a person with disability who needs any accommodation in order to participate in a court proceeding or event, you are entitled, at no cost to you, to the provision of certain assistance. Please contact: in Orange County, ADA Coordinator, Human Resources, Orange County Courthouse, 425 N. Orange Avenue, Suite 510, Orlando, Florida, (407) 836-2303, fax: 407-836-2204; at least 7 days before your scheduled court appearance, or immediately upon receiving notification if the time before the scheduled court appearance is less than 7 days. If you are hearing or voice impaired, call 711 to reach the Telecommunications Relay Service.

August 24th, 2021  
 TIFFANY MOORE RUSSELL  
 CLERK OF THE CIRCUIT COURT  
 ORANGE COUNTY, FLORIDA  
 /s/ Liz Yanira Gordian Olmo  
 Deputy Clerk  
 425 North Orange Ave.  
 Suite 350  
 Orlando, Florida 32801  
 September 2, 9, 2021 21-03189W

**SECOND INSERTION**

IN THE CIRCUIT COURT, IN AND FOR ORANGE COUNTY, FLORIDA.  
**CASE NO.: 21-CA-005649-O #36 HOLIDAY INN CLUB VACATIONS INCORPORATED**  
**Plaintiff, vs.**  
**STANFIELD ET.AL.,**  
**Defendant(s).**

NOTICE OF ACTION  
 Count I

To: GEORGE STANFIELD and JULIA GRES A/K/A S. G. JUL

And all parties claiming interest by, through, under or against Defendant(s) GEORGE STANFIELD and JULIA GRES A/K/A S. G. JUL and all parties having or claiming to have any right, title or interest in the property herein described:

YOU ARE NOTIFIED that an action to foreclose a mortgage/claim of lien on the following described property :

STANDARD Interest(s) in the Orange Lake Land Trust ("Trust") evidenced for administrative, assessment and ownership purposes by 200000 points, which Trust was created pursuant to and further described in that certain Trust Agreement for Orange Lake Land Trust dated December 15, 2017, executed by and among Chicago Title Time-share Land Trust, Inc., a Florida Corporation, as the trustee of the Trust, Holiday Inn Club Vacations Incorporated, a Delaware corporation, f/k/a Orange Lake Country Club, Inc., a Delaware corporation, and Orange Lake Trust Owners' Association, Inc., a Florida not-for-profit corporation, as such agreement may be amended and supplemented from time to time ("Trust Agreement"), a memorandum of which is recorded in Official Records Document Number: 20180061276, Public Records of

Orange County, Florida ("Memorandum of Trust")All of the terms, restrictions, covenants, conditions and provisions contained in the Declaration and any amendments thereto, are incorporated herein by reference with the same effect as though fully set forth herein.

has been filed against you and you are required to serve a copy of your written defenses, if any, to it on Jerry E. Aron, Plaintiff's attorney, whose address is 2505 Metrocentre Blvd., Suite 301, West Palm Beach, Florida, 33407, within thirty (30) days after the first publication of this Notice, and file the original with the Clerk of this Court either before service on Plaintiff's attorney or immediately thereafter, otherwise a default will be entered against you for the relief demanded in the Complaint.

If you are a person with disability who needs any accommodation in order to participate in a court proceeding or event, you are entitled, at no cost to you, to the provision of certain assistance. Please contact: in Orange County, ADA Coordinator, Human Resources, Orange County Courthouse, 425 N. Orange Avenue, Suite 510, Orlando, Florida, (407) 836-2303, fax: 407-836-2204; at least 7 days before your scheduled court appearance, or immediately upon receiving notification if the time before the scheduled court appearance is less than 7 days. If you are hearing or voice impaired, call 711 to reach the Telecommunications Relay Service.

August 23rd, 2021  
 TIFFANY MOORE RUSSELL  
 CLERK OF THE CIRCUIT COURT  
 ORANGE COUNTY, FLORIDA  
 /s/ Lisa Geib  
 DEPUTY CLERK  
 425 North Orange Ave.  
 Suite 350  
 Orlando, Florida 32801  
 September 2, 9, 2021 21-03149W

**SECOND INSERTION**

IN THE CIRCUIT COURT, IN AND FOR ORANGE COUNTY, FLORIDA.  
**CASE NO.: 21-CA-005642-O #40 HOLIDAY INN CLUB VACATIONS INCORPORATED**  
**Plaintiff, vs.**  
**MONTANO ANGULO ET.AL.,**  
**Defendant(s).**

NOTICE OF ACTION  
 Count XII

To: EMMA LAUREN RICH and SAMUEL ANDREW LEACH

And all parties claiming interest by, through, under or against Defendant(s) EMMA LAUREN RICH and SAMUEL ANDREW LEACH and all parties having or claiming to have any right, title or interest in the property herein described:

YOU ARE NOTIFIED that an action to foreclose a mortgage/claim of lien on the following described property :

STANDARD Interest(s) in the Orange Lake Land Trust ("Trust") evidenced for administrative, assessment and ownership purposes by 100000 points, which Trust was created pursuant to and further described in that certain Trust Agreement for Orange Lake Land Trust dated December 15, 2017, executed by and among Chicago Title Time-share Land Trust, Inc., a Florida Corporation, as the trustee of the Trust, Holiday Inn Club Vacations Incorporated, a Delaware corporation, f/k/a Orange Lake Country Club, Inc., a Delaware corporation, and Orange Lake Trust Owners' Association, Inc., a Florida not-for-profit corporation, as such agreement may be amended and supplemented from time to time ("Trust Agreement"), a memorandum of which is recorded in Official Records Document Number: 20180061276, Public Records of

Orange County, Florida ("Memorandum of Trust")All of the terms, restrictions, covenants, conditions and provisions contained in the Declaration and any amendments thereto, are incorporated herein by reference with the same effect as though fully set forth herein.

has been filed against you and you are required to serve a copy of your written defenses, if any, to it on Jerry E. Aron, Plaintiff's attorney, whose address is 2505 Metrocentre Blvd., Suite 301, West Palm Beach, Florida, 33407, within thirty (30) days after the first publication of this Notice, and file the original with the Clerk of this Court either before service on Plaintiff's attorney or immediately thereafter, otherwise a default will be entered against you for the relief demanded in the Complaint.

If you are a person with disability who needs any accommodation in order to participate in a court proceeding or event, you are entitled, at no cost to you, to the provision of certain assistance. Please contact: in Orange County, ADA Coordinator, Human Resources, Orange County Courthouse, 425 N. Orange Avenue, Suite 510, Orlando, Florida, (407) 836-2303, fax: 407-836-2204; at least 7 days before your scheduled court appearance, or immediately upon receiving notification if the time before the scheduled court appearance is less than 7 days. If you are hearing or voice impaired, call 711 to reach the Telecommunications Relay Service.

August 23, 2021  
 TIFFANY MOORE RUSSELL  
 CLERK OF THE CIRCUIT COURT  
 ORANGE COUNTY, FLORIDA  
 /s/ Liz Yanira Gordian Olmo  
 Deputy Clerk  
 425 North Orange Ave.  
 Suite 350  
 Orlando, Florida 32801  
 September 2, 9, 2021 21-03203W

**SECOND INSERTION**

IN THE CIRCUIT COURT, IN AND FOR ORANGE COUNTY, FLORIDA.  
**CASE NO.: 21-CA-005642-O #40 HOLIDAY INN CLUB VACATIONS INCORPORATED**  
**Plaintiff, vs.**  
**MONTANO ANGULO ET.AL.,**  
**Defendant(s).**

NOTICE OF ACTION  
 Count IX

To: DIPAK PHAKEY and JATINDER KAUR PHAKEY

And all parties claiming interest by, through, under or against Defendant(s) DIPAK PHAKEY and JATINDER KAUR PHAKEY and all parties having or claiming to have any right, title or interest in the property herein described:

YOU ARE NOTIFIED that an action to foreclose a mortgage/claim of lien on the following described property :

STANDARD Interest(s) in the Orange Lake Land Trust ("Trust") evidenced for administrative, assessment and ownership purposes by 175000 points, which Trust was created pursuant to and further described in that certain Trust Agreement for Orange Lake Land Trust dated December 15, 2017, executed by and among Chicago Title Time-share Land Trust, Inc., a Florida Corporation, as the trustee of the Trust, Holiday Inn Club Vacations Incorporated, a Delaware corporation, f/k/a Orange Lake Country Club, Inc., a Delaware corporation, and Orange Lake Trust Owners' Association, Inc., a Florida not-for-profit corporation, as such agreement may be amended and supplemented from time to time ("Trust Agreement"), a memorandum of which is recorded in Official Records Document Number: 20180061276, Public Records of

Orange County, Florida ("Memorandum of Trust")All of the terms, restrictions, covenants, conditions and provisions contained in the Declaration and any amendments thereto, are incorporated herein by reference with the same effect as though fully set forth herein.

has been filed against you and you are required to serve a copy of your written defenses, if any, to it on Jerry E. Aron, Plaintiff's attorney, whose address is 2505 Metrocentre Blvd., Suite 301, West Palm Beach, Florida, 33407, within thirty (30) days after the first publication of this Notice, and file the original with the Clerk of this Court either before service on Plaintiff's attorney or immediately thereafter, otherwise a default will be entered against you for the relief demanded in the Complaint.

If you are a person with disability who needs any accommodation in order to participate in a court proceeding or event, you are entitled, at no cost to you, to the provision of certain assistance. Please contact: in Orange County, ADA Coordinator, Human Resources, Orange County Courthouse, 425 N. Orange Avenue, Suite 510, Orlando, Florida, (407) 836-2303, fax: 407-836-2204; at least 7 days before your scheduled court appearance, or immediately upon receiving notification if the time before the scheduled court appearance is less than 7 days. If you are hearing or voice impaired, call 711 to reach the Telecommunications Relay Service.

August 23rd, 2021  
 TIFFANY MOORE RUSSELL  
 CLERK OF THE CIRCUIT COURT  
 ORANGE COUNTY, FLORIDA  
 /s/ Liz Yanira Gordian Olmo  
 Deputy Clerk  
 425 North Orange Ave.  
 Suite 350  
 Orlando, Florida 32801  
 September 2, 9, 2021 21-03200W







ORANGE COUNTY  
SUBSEQUENT INSERTIONS

SECOND INSERTION

RE-NOTICE OF SALE PURSUANT TO CHAPTER 45 IN THE CIRCUIT COURT OF THE NINTH JUDICIAL CIRCUIT IN AND FOR ORANGE COUNTY, FLORIDA.  
GENERAL JURISDICTION DIVISION  
CASE NO. 2018-CA-002563-O  
DEUTSCHE BANK NATIONAL TRUST COMPANY, AS TRUSTEE, ON BEHALF OF THE HOLDERS OF THE IMPAC SECURED ASSETS CORP. MORTGAGE PASS-THROUGH CERTIFICATES SERIES 2007-3,  
Plaintiff, vs.  
AMILCAR RODRIGUEZ; IVANILDE SILVA; ZB, NATIONAL ASSOCIATION, SUCCESSOR IN INTEREST TO SILVER STATE BANK; MORTGAGE ELECTRONIC REGISTRATION SYSTEMS, INC.

AS NOMINEE FOR EXPRESS CAPITAL LENDING; VIZCAYA MASTER HOMEOWNERS' ASSOCIATION, INC.; CADLES OF WEST VIRGINIA LLC; UNKNOWN TENANT NO. 1; UNKNOWN TENANT NO. 2; and ALL UNKNOWN PARTIES CLAIMING INTERESTS BY, THROUGH, UNDER OR AGAINST A NAMED DEFENDANT TO THIS ACTION, OR HAVING OR CLAIMING TO HAVE ANY RIGHT, TITLE OR INTEREST IN THE PROPERTY HEREIN DESCRIBED,  
Defendant(s).  
NOTICE IS HEREBY GIVEN pursuant to an Order or Summary Final Judgment of foreclosure dated May 20, 2019 and an Order Cancelling and Resetting Sale dated August 18, 2021 and entered in Case No. 2018-CA-002563-O of the Circuit

Court in and for Orange County, Florida, wherein DEUTSCHE BANK NATIONAL TRUST COMPANY, AS TRUSTEE, ON BEHALF OF THE HOLDERS OF THE IMPAC SECURED ASSETS CORP. MORTGAGE PASS-THROUGH CERTIFICATES SERIES 2007-3 is Plaintiff and AMILCAR RODRIGUEZ; IVANILDE SILVA; ZB, NATIONAL ASSOCIATION, SUCCESSOR IN INTEREST TO SILVER STATE BANK; MORTGAGE ELECTRONIC REGISTRATION SYSTEMS, INC. AS NOMINEE FOR EXPRESS CAPITAL LENDING; VIZCAYA MASTER HOMEOWNERS' ASSOCIATION, INC.; CADLES OF WEST VIRGINIA LLC; UNKNOWN TENANT NO. 1; UNKNOWN TENANT NO. 2; and ALL UNKNOWN PARTIES CLAIMING INTERESTS BY, THROUGH, UNDER OR AGAINST A NAMED

DEFENDANT TO THIS ACTION, OR HAVING OR CLAIMING TO HAVE ANY RIGHT, TITLE OR INTEREST IN THE PROPERTY HEREIN DESCRIBED, are Defendants, TIFFANY MOORE RUSSELL, Clerk of the Circuit Court, will sell to the highest and best bidder for cash www.myorangeclerk.realforeclose.com, 11:00 A.M., on October 11, 2021, the following described property as set forth in said Order or Final Judgment, to-wit:  
LOT 15F, BLOCK F, VIZCAYA PHASE ONE, ACCORDING TO MAP OR PLAT THEREOF AS RECORDED IN PLAT BOOK 45, PAGES 29 THROUGH 34, OF THE PUBLIC RECORDS OF ORANGE COUNTY, FLORIDA.  
ANY PERSON CLAIMING AN INTEREST IN THE SURPLUS FROM THE SALE, IF ANY, OTHER THAN

THE PROPERTY OWNER AS OF THE DATE OF THE LIS PENDENS MUST FILE A CLAIM BEFORE THE CLERK REPORTS THE SURPLUS AS UNCLAIMED. THE COURT, IN ITS DISCRETION, MAY ENLARGE THE TIME OF THE SALE. NOTICE OF THE CHANGED TIME OF SALE SHALL BE PUBLISHED AS PROVIDED HEREIN.  
If you are a person with a disability who needs any accommodation in order to participate in this proceeding, you are entitled, at no cost to you, to the provision of certain assistance. Please contact the ADA Coordinator, Human Resources, Orange County Courthouse, 425 N. Orange Avenue, Suite 510, Orlando, Florida, (407) 836-2303, at least 7 days before your scheduled court appearance, or immediately upon receiving this notification if the time before the scheduled appearance is less than

7 days; if you are hearing or voice impaired, call 711.  
Pursuant to Florida Statute 45.031(2), this notice shall be published twice, once a week for two consecutive weeks, with the last publication being at least 5 days prior to the sale.  
DATED 26th August, 2021.  
By: /s/ Fazia Corsbie  
Fazia S. Corsbie  
Florida Bar No.: 978728  
Roy Diaz, Attorney of Record  
Florida Bar No. 767700  
Diaz Anselmo & Associates, P.A.  
Attorneys for Plaintiff  
499 NW 70th Ave., Suite 309  
Fort Lauderdale, FL 33317  
Telephone: (954) 564-0071  
Facsimile: (954) 564-9252  
Service E-mail:  
answers@dallegal.com  
1162-166019 / BJB  
September 2, 9, 2021 21-03002W

SECOND INSERTION

IN THE CIRCUIT COURT, IN AND FOR ORANGE COUNTY, FLORIDA.  
CASE NO.: 21-CA-006284-O #36  
HOLIDAY INN CLUB VACATIONS INCORPORATED  
Plaintiff, vs.  
FAARUP ET.AL.,  
Defendant(s).  
NOTICE OF ACTION  
Count II  
To: CARLOS ANDRES GONZALEZ TAMAYO and YESICA MILENA JIMENEZ PEREZ  
And all parties claiming interest by, through, under or against Defendant(s) CARLOS ANDRES GONZALEZ TAMAYO and YESICA MILENA JIMENEZ PEREZ and all parties having or claiming to have any right, title or interest in the property herein described.  
YOU ARE NOTIFIED that an action to foreclose a mortgage/claim of lien on the following described property :  
STANDARD Interest(s) in the Orange Lake Land Trust ("Trust") evidenced for administrative, assessment and ownership purposes by 40000 points, which Trust was created pursuant to and further described in that certain Trust Agreement for Orange Lake Land Trust dated December 15, 2017, executed by and among Chicago Title Time-share Land Trust, Inc., a Florida Corporation, as the trustee of the Trust, Holiday Inn Club Vacations Incorporated, a Delaware corporation, f/k/a Orange Lake Country Club, Inc., a Delaware corporation, and Orange Lake Trust Owners' Association, Inc., a Florida not-for-profit corporation, as such agreement may be amended and supplemented from time to time ("Trust Agreement"), a memorandum of which is recorded in Official Records Document Number:

20180061276, Public Records of Orange County, Florida ("Memorandum of Trust")All of the terms, restrictions, covenants, conditions and provisions contained in the Declaration and any amendments thereto, are incorporated herein by reference with the same effect as though fully set forth herein.  
has been filed against you and you are required to serve a copy of your written defenses, if any, to it on Jerry E. Aron, Plaintiff's attorney, whose address is 2505 Metrocentre Blvd., Suite 301, West Palm Beach, Florida, 33407, within thirty (30) days after the first publication of this Notice, and file the original with the Clerk of this Court either before service on Plaintiff's attorney or immediately thereafter, otherwise a default will be entered against you for the relief demanded in the Complaint.  
If you are a person with disability who needs any accommodation in order to participate in a court proceeding or event, you are entitled, at no cost to you, to the provision of certain assistance. Please contact: in Orange County, ADA Coordinator, Human Resources, Orange County Courthouse, 425 N. Orange Avenue, Suite 510, Orlando, Florida, (407) 836-2303, fax: 407-836-2204; at least 7 days before your scheduled court appearance, or immediately upon receiving notification if the time before the scheduled court appearance is less than 7 days. If you are hearing or voice impaired, call 711 to reach the Telecommunications Relay Service.  
TIFFANY MOORE RUSSELL  
CLERK OF THE CIRCUIT COURT  
ORANGE COUNTY, FLORIDA  
8/19/2021  
/s/ Lisa Geib  
425 North Orange Ave.  
Suite 350  
Orlando, Florida 32801  
September 2, 9, 2021 21-03131W

IN THE CIRCUIT COURT, IN AND FOR ORANGE COUNTY, FLORIDA.  
CASE NO.: 21-CA-004899-O #36  
HOLIDAY INN CLUB VACATIONS INCORPORATED  
Plaintiff, vs.  
AGUILERA JOPIA ET.AL.,  
Defendant(s).  
NOTICE OF ACTION  
Count IX  
To: SAMANTHA CARTWRIGHT A/K/A SAMANTHA R. CARTWRIGHT and MICHAEL ANGELO T. CARTWRIGHT  
And all parties claiming interest by, through, under or against Defendant(s) SAMANTHA CARTWRIGHT A/K/A SAMANTHA R. CARTWRIGHT and MICHAEL ANGELO T. CARTWRIGHT and all parties having or claiming to have any right, title or interest in the property herein described.  
YOU ARE NOTIFIED that an action to foreclose a mortgage/claim of lien on the following described property :  
STANDARD Interest(s) in the Orange Lake Land Trust ("Trust") evidenced for administrative, assessment and ownership purposes by 60000 points, which Trust was created pursuant to and further described in that certain Trust Agreement for Orange Lake Land Trust dated December 15, 2017, executed by and among Chicago Title Time-share Land Trust, Inc., a Florida Corporation, as the trustee of the Trust, Holiday Inn Club Vacations Incorporated, a Delaware corporation, f/k/a Orange Lake Country Club, Inc., a Delaware corporation, and Orange Lake Trust Owners' Association, Inc., a Florida not-for-profit corporation, as such agreement may be amended and supplemented from time to time ("Trust Agreement"), a memorandum of which is recorded in Official

Records Document Number: 20180061276, Public Records of Orange County, Florida ("Memorandum of Trust")All of the terms, restrictions, covenants, conditions and provisions contained in the Declaration and any amendments thereto, are incorporated herein by reference with the same effect as though fully set forth herein.  
has been filed against you and you are required to serve a copy of your written defenses, if any, to it on Jerry E. Aron, Plaintiff's attorney, whose address is 2505 Metrocentre Blvd., Suite 301, West Palm Beach, Florida, 33407, within thirty (30) days after the first publication of this Notice, and file the original with the Clerk of this Court either before service on Plaintiff's attorney or immediately thereafter, otherwise a default will be entered against you for the relief demanded in the Complaint.  
If you are a person with disability who needs any accommodation in order to participate in a court proceeding or event, you are entitled, at no cost to you, to the provision of certain assistance. Please contact: in Orange County, ADA Coordinator, Human Resources, Orange County Courthouse, 425 N. Orange Avenue, Suite 510, Orlando, Florida, (407) 836-2303, fax: 407-836-2204; at least 7 days before your scheduled court appearance, or immediately upon receiving notification if the time before the scheduled court appearance is less than 7 days. If you are hearing or voice impaired, call 711 to reach the Telecommunications Relay Service.  
TIFFANY MOORE RUSSELL  
CLERK OF THE CIRCUIT COURT  
ORANGE COUNTY, FLORIDA  
/s/ yamina azzizi  
deputy clerk  
425 North Orange Ave.  
Suite 350  
Orlando, Florida 32801  
September 2, 9, 2021 21-03126W

SECOND INSERTION

IN THE CIRCUIT COURT, IN AND FOR ORANGE COUNTY, FLORIDA.  
CASE NO.: 21-CA-004899-O #36  
HOLIDAY INN CLUB VACATIONS INCORPORATED  
Plaintiff, vs.  
AGUILERA JOPIA ET.AL.,  
Defendant(s).  
NOTICE OF ACTION  
Count VIII  
To: MARTIN FRANCISCO CARDONA JIMENEZ and CLAUDIA ELIZABETH ESPINOZA IZAGUIRRE  
And all parties claiming interest by, through, under or against Defendant(s) MARTIN FRANCISCO CARDONA JIMENEZ and CLAUDIA ELIZABETH ESPINOZA IZAGUIRRE and all parties having or claiming to have any right, title or interest in the property herein described.  
YOU ARE NOTIFIED that an action to foreclose a mortgage/claim of lien on the following described property :  
STANDARD Interest(s) in the Orange Lake Land Trust ("Trust") evidenced for administrative, assessment and ownership purposes by 40000 points, which Trust was created pursuant to and further described in that certain Trust Agreement for Orange Lake Land Trust dated December 15, 2017, executed by and among Chicago Title Time-share Land Trust, Inc., a Florida Corporation, as the trustee of the Trust, Holiday Inn Club Vacations Incorporated, a Delaware corporation, f/k/a Orange Lake Country Club, Inc., a Delaware corporation, and Orange Lake Trust Owners' Association, Inc., a Florida not-for-profit corporation, as such agreement may be amended and supplemented from time to time ("Trust Agreement"), a memorandum of which is recorded in Official Records Document Number:

20180061276, Public Records of Orange County, Florida ("Memorandum of Trust")All of the terms, restrictions, covenants, conditions and provisions contained in the Declaration and any amendments thereto, are incorporated herein by reference with the same effect as though fully set forth herein.  
has been filed against you and you are required to serve a copy of your written defenses, if any, to it on Jerry E. Aron, Plaintiff's attorney, whose address is 2505 Metrocentre Blvd., Suite 301, West Palm Beach, Florida, 33407, within thirty (30) days after the first publication of this Notice, and file the original with the Clerk of this Court either before service on Plaintiff's attorney or immediately thereafter, otherwise a default will be entered against you for the relief demanded in the Complaint.  
If you are a person with disability who needs any accommodation in order to participate in a court proceeding or event, you are entitled, at no cost to you, to the provision of certain assistance. Please contact: in Orange County, ADA Coordinator, Human Resources, Orange County Courthouse, 425 N. Orange Avenue, Suite 510, Orlando, Florida, (407) 836-2303, fax: 407-836-2204; at least 7 days before your scheduled court appearance, or immediately upon receiving notification if the time before the scheduled court appearance is less than 7 days. If you are hearing or voice impaired, call 711 to reach the Telecommunications Relay Service.  
TIFFANY MOORE RUSSELL  
CLERK OF THE CIRCUIT COURT  
ORANGE COUNTY, FLORIDA  
/s/ yamina azzizi  
deputy clerk  
425 North Orange Ave.  
Suite 350  
Orlando, Florida 32801  
September 2, 9, 2021 21-03125W

SECOND INSERTION

IN THE CIRCUIT COURT, IN AND FOR ORANGE COUNTY, FLORIDA.  
CASE NO.: 21-CA-005649-O #36  
HOLIDAY INN CLUB VACATIONS INCORPORATED  
Plaintiff, vs.  
STANFIELD ET.AL.,  
Defendant(s).  
NOTICE OF ACTION  
Count VI  
To: MARILYN V. THOMAS and MALACHI I. YISRAEL AND ANY AND ALL UNKNOWN HEIRS, DEVISEES AND OTHER CLAIMANTS OF MALACHI I. YISRAEL  
And all parties claiming interest by, through, under or against Defendant(s) MARILYN V. THOMAS and MALACHI I. YISRAEL AND ANY AND ALL UNKNOWN HEIRS, DEVISEES AND OTHER CLAIMANTS OF MALACHI I. YISRAEL and all parties having or claiming to have any right, title or interest in the property herein described.  
YOU ARE NOTIFIED that an action to foreclose a mortgage/claim of lien on the following described property :  
STANDARD Interest(s) in the Orange Lake Land Trust ("Trust") evidenced for administrative, assessment and ownership purposes by 75000 points, which Trust was created pursuant to and further described in that certain Trust Agreement for Orange Lake Land Trust dated December 15, 2017, executed by and among Chicago Title Time-share Land Trust, Inc., a Florida Corporation, as the trustee of the Trust, Holiday Inn Club Vacations Incorporated, a Delaware corporation, f/k/a Orange Lake Country Club, Inc., a Delaware corporation, and Orange Lake Trust Owners' Association, Inc., a Florida not-for-profit corporation, as such agreement may be amended and supplemented from time to time ("Trust Agreement"), a memorandum of which is recorded in Official Records Document

Number: 20180061276, Public Records of Orange County, Florida ("Memorandum of Trust") All of the terms, restrictions, covenants, conditions and provisions contained in the Declaration and any amendments thereto, are incorporated herein by reference with the same effect as though fully set forth herein.  
has been filed against you and you are required to serve a copy of your written defenses, if any, to it on Jerry E. Aron, Plaintiff's attorney, whose address is 2505 Metrocentre Blvd., Suite 301, West Palm Beach, Florida, 33407, within thirty (30) days after the first publication of this Notice, and file the original with the Clerk of this Court either before service on Plaintiff's attorney or immediately thereafter, otherwise a default will be entered against you for the relief demanded in the Complaint.  
If you are a person with disability who needs any accommodation in order to participate in a court proceeding or event, you are entitled, at no cost to you, to the provision of certain assistance. Please contact: in Orange County, ADA Coordinator, Human Resources, Orange County Courthouse, 425 N. Orange Avenue, Suite 510, Orlando, Florida, (407) 836-2303, fax: 407-836-2204; at least 7 days before your scheduled court appearance, or immediately upon receiving notification if the time before the scheduled court appearance is less than 7 days. If you are hearing or voice impaired, call 711 to reach the Telecommunications Relay Service.  
TIFFANY MOORE RUSSELL  
CLERK OF THE CIRCUIT COURT  
ORANGE COUNTY, FLORIDA  
8/19/2021  
/s/ Lisa Geib  
DEPUTY CLERK  
425 North Orange Ave.  
Suite 350  
Orlando, Florida 32801  
September 2, 9, 2021 21-03154W

SECOND INSERTION

IN THE CIRCUIT COURT, IN AND FOR ORANGE COUNTY, FLORIDA.  
CASE NO.: 21-CA-005642-O #40  
HOLIDAY INN CLUB VACATIONS INCORPORATED  
Plaintiff, vs.  
MONTANO ANGULO ET.AL.,  
Defendant(s).  
NOTICE OF ACTION  
Count II  
To: GLENDA MECHELLE MORTON and NIKETA LATRESE GRAVES AND ANY AND ALL UNKNOWN HEIRS, DEVISEES AND OTHER CLAIMANTS OF NIKETA LATRESE GRAVES  
And all parties claiming interest by, through, under or against Defendant(s) GLENDA MECHELLE MORTON and NIKETA LATRESE GRAVES AND ANY AND ALL UNKNOWN HEIRS, DEVISEES AND OTHER CLAIMANTS OF NIKETA LATRESE GRAVES and all parties having or claiming to have any right, title or interest in the property herein described.  
YOU ARE NOTIFIED that an action to foreclose a mortgage/claim of lien on the following described property :  
STANDARD Interest(s) in the Orange Lake Land Trust ("Trust") evidenced for administrative, assessment and ownership purposes by 50000 points, which Trust was created pursuant to and further described in that certain Trust Agreement for Orange Lake Land Trust dated December 15, 2017, executed by and among Chicago Title Time-share Land Trust, Inc., a Florida Corporation, as the trustee of the Trust, Holiday Inn Club Vacations Incorporated, a Delaware corporation, f/k/a Orange Lake Country Club, Inc., a Delaware corporation, and Orange Lake Trust Owners' Association, Inc., a Florida not-for-profit corporation, as such agreement may be amended and supplemented from time to time ("Trust

Agreement"), a memorandum of which is recorded in Official Records Document Number: 20180061276, Public Records of Orange County, Florida ("Memorandum of Trust")All of the terms, restrictions, covenants, conditions and provisions contained in the Declaration and any amendments thereto, are incorporated herein by reference with the same effect as though fully set forth herein.  
has been filed against you and you are required to serve a copy of your written defenses, if any, to it on Jerry E. Aron, Plaintiff's attorney, whose address is 2505 Metrocentre Blvd., Suite 301, West Palm Beach, Florida, 33407, within thirty (30) days after the first publication of this Notice, and file the original with the Clerk of this Court either before service on Plaintiff's attorney or immediately thereafter, otherwise a default will be entered against you for the relief demanded in the Complaint.  
If you are a person with disability who needs any accommodation in order to participate in a court proceeding or event, you are entitled, at no cost to you, to the provision of certain assistance. Please contact: in Orange County, ADA Coordinator, Human Resources, Orange County Courthouse, 425 N. Orange Avenue, Suite 510, Orlando, Florida, (407) 836-2303, fax: 407-836-2204; at least 7 days before your scheduled court appearance, or immediately upon receiving notification if the time before the scheduled court appearance is less than 7 days. If you are hearing or voice impaired, call 711 to reach the Telecommunications Relay Service.  
August 23rd, 2021  
TIFFANY MOORE RUSSELL  
CLERK OF THE CIRCUIT COURT  
ORANGE COUNTY, FLORIDA  
/s/ Liz Yanira Gordian Olmo  
Deputy Clerk  
425 North Orange Ave.  
Suite 350  
Orlando, Florida 32801  
September 2, 9, 2021 21-03193W

SECOND INSERTION

IN THE CIRCUIT COURT, IN AND FOR ORANGE COUNTY, FLORIDA.  
CASE NO.: 21-CA-005649-O #36  
HOLIDAY INN CLUB VACATIONS INCORPORATED  
Plaintiff, vs.  
STANFIELD ET.AL.,  
Defendant(s).  
NOTICE OF ACTION  
Count III  
To: KAREN SZYMANIK A/K/A KAREN LEE MCMULLEN and MICHAEL PATRICK MCMULLEN AND ANY AND ALL UNKNOWN HEIRS, DEVISEES AND OTHER CLAIMANTS OF MICHAEL PATRICK MCMULLEN  
And all parties claiming interest by, through, under or against Defendant(s) KAREN SZYMANIK A/K/A KAREN LEE MCMULLEN and MICHAEL PATRICK MCMULLEN AND ANY AND ALL UNKNOWN HEIRS, DEVISEES AND OTHER CLAIMANTS OF MICHAEL PATRICK MCMULLEN and all parties having or claiming to have any right, title or interest in the property herein described.  
YOU ARE NOTIFIED that an action to foreclose a mortgage/claim of lien on the following described property :  
STANDARD Interest(s) in the Orange Lake Land Trust ("Trust") evidenced for administrative, assessment and ownership purposes by 150000 points, which Trust was created pursuant to and further described in that certain Trust Agreement for Orange Lake Land Trust dated December 15, 2017, executed by and among Chicago Title Time-share Land Trust, Inc., a Florida Corporation, as the trustee of the Trust, Holiday Inn Club Vacations Incorporated, a Delaware corporation, f/k/a Orange Lake Country Club, Inc., a Delaware corporation, and Orange Lake Trust Owners' Association, Inc., a Florida not-for-profit corporation, as such agreement may be amended and supplemented from time to time ("Trust

Agreement"), a memorandum of which is recorded in Official Records Document Number: 20180061276, Public Records of Orange County, Florida ("Memorandum of Trust")All of the terms, restrictions, covenants, conditions and provisions contained in the Declaration and any amendments thereto, are incorporated herein by reference with the same effect as though fully set forth herein.  
has been filed against you and you are required to serve a copy of your written defenses, if any, to it on Jerry E. Aron, Plaintiff's attorney, whose address is 2505 Metrocentre Blvd., Suite 301, West Palm Beach, Florida, 33407, within thirty (30) days after the first publication of this Notice, and file the original with the Clerk of this Court either before service on Plaintiff's attorney or immediately thereafter, otherwise a default will be entered against you for the relief demanded in the Complaint.  
If you are a person with disability who needs any accommodation in order to participate in a court proceeding or event, you are entitled, at no cost to you, to the provision of certain assistance. Please contact: in Orange County, ADA Coordinator, Human Resources, Orange County Courthouse, 425 N. Orange Avenue, Suite 510, Orlando, Florida, (407) 836-2303, fax: 407-836-2204; at least 7 days before your scheduled court appearance, or immediately upon receiving notification if the time before the scheduled court appearance is less than 7 days. If you are hearing or voice impaired, call 711 to reach the Telecommunications Relay Service.  
TIFFANY MOORE RUSSELL  
CLERK OF THE CIRCUIT COURT  
ORANGE COUNTY, FLORIDA  
8/19/2021  
/s/ Lisa Geib  
DEPUTY CLERK  
425 North Orange Ave.  
Suite 350  
Orlando, Florida 32801  
September 2, 9, 2021 21-03151W





ORANGE COUNTY  
SUBSEQUENT INSERTIONS

SECOND INSERTION

IN THE CIRCUIT COURT, IN AND FOR ORANGE COUNTY, FLORIDA.

**CASE NO.: 21-CA-005969-O #33**  
**HOLIDAY INN CLUB VACATIONS INCORPORATED**  
**Plaintiff, vs.**  
**DALGITY ET.AL.,**  
**Defendant(s).**

NOTICE OF ACTION  
Count IV  
(ON AMENDED COMPLAINT)

To: NANCY E. LAMBER and JOSEPH R. D'ALESSIO AND ANY AND ALL UNKNOWN HEIRS, DEVISEES AND OTHER CLAIMANTS OF JOSEPH R. D'ALESSIO

And all parties claiming interest by, through, under or against Defendant(s) NANCY E. LAMBER and JOSEPH R. D'ALESSIO AND ANY AND ALL UNKNOWN HEIRS, DEVISEES AND OTHER CLAIMANTS OF JOSEPH R. D'ALESSIO and all parties having or claiming to have any right, title or interest in the property herein described:

YOU ARE NOTIFIED that an action to foreclose a mortgage/claim of lien on the following described property in Orange County, Florida:

WEEK/UNIT:  
42/003005

of Orange Lake Country Club Villas I, a Condominium, together with an undivided interest in the common elements appurtenant thereto, according to the Declaration of Condominium thereof recorded in Official Records Book 3300, Page 2702, in the Public Records of Orange County, Florida, and all amendments thereto; the plat of which is recorded in Condominium Book 7, page 59 until 12:00 noon on the first Saturday 2061, at which date said estate shall terminate; TOGETHER with a remainder over in fee simple absolute as tenant in common with the other owners of all the unit weeks in the above described Condominium in the percentage interest established in the Declaration of Condominium.

has been filed against you and you are required to serve a copy of your written defenses, if any, to it on Jerry E. Aron, Plaintiff's attorney, whose address is 2505 Metrocentre Blvd., Suite 301, West Palm Beach, Florida, 33407, within thirty (30) days after the first publication of this Notice, and file the original with the Clerk of this

Court either before service on Plaintiff's attorney or immediately thereafter, otherwise a default will be entered against you for the relief demanded in the Complaint.

If you are a person with disability who needs any accommodation in order to participate in a court proceeding or event, you are entitled, at no cost to you, to the provision of certain assistance. Please contact: in Orange County, ADA Coordinator, Human Resources, Orange County Courthouse, 425 N. Orange Avenue, Suite 510, Orlando, Florida, (407) 836-2303, fax: 407-836-2204; at least 7 days before your scheduled court appearance, or immediately upon receiving notification if the time before the scheduled court appearance is less than 7 days. If you are hearing or voice impaired, call 711 to reach the Telecommunications Relay Service.

TIFFANY MOORE RUSSELL  
CLERK OF THE CIRCUIT COURT  
ORANGE COUNTY, FLORIDA  
August 24th, 2021  
/s/ Liz Yanira Gordian Olmo  
425 North Orange Ave.  
Suite 350  
Orlando, Florida 32801  
September 2, 9, 2021 21-03036W

SECOND INSERTION

IN THE CIRCUIT COURT, IN AND FOR ORANGE COUNTY, FLORIDA.

**CASE NO.: 21-CA-006287-O #33**  
**HOLIDAY INN CLUB VACATIONS INCORPORATED**  
**Plaintiff, vs.**  
**PAOLETTI ET.AL.,**  
**Defendant(s).**

NOTICE OF ACTION  
Count VI

To: ROBERTO F. VASQUEZ and HEYNELDA B. MARCANO AND ANY AND ALL UNKNOWN HEIRS, DEVISEES AND OTHER CLAIMANTS OF HEYNELDA B. MARCANO

And all parties claiming interest by, through, under or against Defendant(s) ROBERTO F. VASQUEZ and HEYNELDA B. MARCANO AND ANY AND ALL UNKNOWN HEIRS, DEVISEES AND OTHER CLAIMANTS OF HEYNELDA B. MARCANO and all parties having or claiming to have any right, title or interest in the property herein described:

YOU ARE NOTIFIED that an action to foreclose a mortgage/claim of lien on the following described property in Orange County, Florida:

WEEK/UNIT:  
35/088142  
of Orange Lake Country Club

Villas III, a Condominium, together with an undivided interest in the common elements appurtenant thereto, according to the Declaration of Condominium thereof recorded in Official Records Book 5914, Page 1965, in the Public Records of Orange County, Florida, and all amendments thereto; the plat of which is recorded in Condominium Book 28, page 84-92 until 12:00 noon on the first Saturday 2071, at which date said estate shall terminate; TOGETHER with a remainder over in fee simple absolute as tenant in common with the other owners of all the unit weeks in the above described Condominium in the percentage interest established in the Declaration of Condominium.

has been filed against you and you are required to serve a copy of your written defenses, if any, to it on Jerry E. Aron, Plaintiff's attorney, whose address is 2505 Metrocentre Blvd., Suite 301, West Palm Beach, Florida, 33407, within thirty (30) days after the first publication of this Notice, and file the original with the Clerk of this Court either before service on Plain-

tiff's attorney or immediately thereafter, otherwise a default will be entered against you for the relief demanded in the Complaint.

If you are a person with disability who needs any accommodation in order to participate in a court proceeding or event, you are entitled, at no cost to you, to the provision of certain assistance. Please contact: in Orange County, ADA Coordinator, Human Resources, Orange County Courthouse, 425 N. Orange Avenue, Suite 510, Orlando, Florida, (407) 836-2303, fax: 407-836-2204; at least 7 days before your scheduled court appearance, or immediately upon receiving notification if the time before the scheduled court appearance is less than 7 days. If you are hearing or voice impaired, call 711 to reach the Telecommunications Relay Service.

TIFFANY MOORE RUSSELL  
CLERK OF THE CIRCUIT COURT  
ORANGE COUNTY, FLORIDA  
08/19/2021  
/s/ RAMONA VELEZ,  
DEPUTY CLERK  
425 North Orange Ave.  
Suite 350  
Orlando, Florida 32801  
September 2, 9, 2021 21-03046W

SECOND INSERTION

IN THE CIRCUIT COURT, IN AND FOR ORANGE COUNTY, FLORIDA.

**CASE NO.: 21-CA-006283-O #35**  
**HOLIDAY INN CLUB VACATIONS INCORPORATED**  
**Plaintiff, vs.**  
**ALI AKBARI ET.AL.,**  
**Defendant(s).**

NOTICE OF ACTION  
Count VIII

To: ALEJANDRO COTO ALVARADO and ROXANA RAMIREZ NAVARRO AND all parties claiming interest by, through, under or against Defendant(s) ALEJANDRO COTO ALVARADO and ROXANA RAMIREZ NAVARRO and all parties having or claiming to have any right, title or interest in the property herein described:

YOU ARE NOTIFIED that an action to foreclose a mortgage/claim of lien on the following described property:

STANDARD Interest(s) in the Orange Lake Land Trust ("Trust") evidenced for administrative, assessment and ownership purposes by 45000 points, which Trust was created pursuant to and further described in that certain Trust Agreement for Orange Lake Land Trust dated December 15, 2017, executed by and among Chicago Title Timeshare Land Trust, Inc., a Florida Corporation, as the trustee of the Trust, Holiday Inn Club Vacations Incorporated, a Delaware corporation, f/k/a Orange Lake Country Club, Inc., a Delaware corporation, and Orange Lake Trust Owners' Association, Inc., a Florida not-for-profit corporation, as such agreement may be amended and supplemented from time to time ("Trust Agreement"), a memorandum of which is recorded in Official Records Document Number: 20180061276, Public Records of Orange County, Florida ("Memorandum of Trust")

All of the terms, restrictions, covenants, conditions and provisions contained in the Declaration and any amendments thereto, are incorporated herein by reference with the same effect as though fully set forth herein.

has been filed against you and you are required to serve a copy of your written defenses, if any, to it on Jerry E. Aron, Plaintiff's attorney, whose address is 2505 Metrocentre Blvd., Suite 301, West Palm Beach, Florida, 33407, within thirty (30) days after the first publication of this Notice, and file the original with the Clerk of this Court either before service on Plaintiff's attorney or immediately thereafter, otherwise a default will be entered against you for the relief demanded in the Complaint.

If you are a person with disability who needs any accommodation in order to participate in a court proceeding or event, you are entitled, at no cost to you, to the provision of certain assistance. Please contact: in Orange County, ADA Coordinator, Human Resources, Orange County Courthouse, 425 N. Orange Avenue, Suite 510, Orlando, Florida, (407) 836-2303, fax: 407-836-2204; at least 7 days before your scheduled court appearance, or immediately upon receiving notification if the time before the scheduled court appearance is less than 7 days. If you are hearing or voice impaired, call 711 to reach the Telecommunications Relay Service.

TIFFANY MOORE RUSSELL  
CLERK OF THE CIRCUIT COURT  
ORANGE COUNTY, FLORIDA  
8/19/2021  
/s/ Lisa Geib  
DEPUTY CLERK  
425 North Orange Ave.  
Suite 350  
Orlando, Florida 32801  
September 2, 9, 2021 21-03090W

SECOND INSERTION

IN THE CIRCUIT COURT, IN AND FOR ORANGE COUNTY, FLORIDA.

**CASE NO.: 21-CA-005589-O #34**  
**HOLIDAY INN CLUB VACATIONS INCORPORATED**  
**Plaintiff, vs.**  
**ARANEDA CRUZ ET.AL.,**  
**Defendant(s).**

NOTICE OF ACTION  
Count VIII

To: SERGIO GERARDO IBARRA SEDENO and YAZMIN MARCELA GRANADOS GONZALEZ

And all parties claiming interest by, through, under or against Defendant(s) SERGIO GERARDO IBARRA SEDENO and YAZMIN MARCELA GRANADOS GONZALEZ and all parties having or claiming to have any right, title or interest in the property herein described:

YOU ARE NOTIFIED that an action to foreclose a mortgage/claim of lien on the following described property:

STANDARD Interest(s) in the Orange Lake Land Trust ("Trust") evidenced for administrative, assessment and ownership purposes by 100000 points, which Trust was created pursuant to and further described in that certain Trust Agreement for Orange Lake Land Trust dated December 15, 2017, executed by and among Chicago Title Timeshare Land Trust, Inc., a Florida Corporation, as the trustee of the Trust, Holiday Inn Club Vacations Incorporated, a Delaware corporation, f/k/a Orange Lake Country Club, Inc., a Delaware corporation, and Orange Lake Trust Owners' Association, Inc., a Florida not-for-profit corporation, as such agreement may be amended and supplemented from time to time ("Trust Agreement"), a memorandum of which is recorded in Official Records Document Number:

SECOND INSERTION

20180061276, Public Records of Orange County, Florida ("Memorandum of Trust")All of the terms, restrictions, covenants, conditions and provisions contained in the Declaration and any amendments thereto, are incorporated herein by reference with the same effect as though fully set forth herein.

has been filed against you and you are required to serve a copy of your written defenses, if any, to it on Jerry E. Aron, Plaintiff's attorney, whose address is 2505 Metrocentre Blvd., Suite 301, West Palm Beach, Florida, 33407, within thirty (30) days after the first publication of this Notice, and file the original with the Clerk of this Court either before service on Plaintiff's attorney or immediately thereafter, otherwise a default will be entered against you for the relief demanded in the Complaint.

If you are a person with disability who needs any accommodation in order to participate in a court proceeding or event, you are entitled, at no cost to you, to the provision of certain assistance. Please contact: in Orange County, ADA Coordinator, Human Resources, Orange County Courthouse, 425 N. Orange Avenue, Suite 510, Orlando, Florida, (407) 836-2303, fax: 407-836-2204; at least 7 days before your scheduled court appearance, or immediately upon receiving notification if the time before the scheduled court appearance is less than 7 days. If you are hearing or voice impaired, call 711 to reach the Telecommunications Relay Service.

TIFFANY MOORE RUSSELL  
CLERK OF THE CIRCUIT COURT  
ORANGE COUNTY, FLORIDA  
8/18/2021  
/s/ Nancy Garcia,  
DEPUTY CLERK  
425 North Orange Ave.  
Suite 350  
Orlando, Florida 32801  
September 2, 9, 2021 21-03074W

SECOND INSERTION

IN THE CIRCUIT COURT, IN AND FOR ORANGE COUNTY, FLORIDA.

**CASE NO.: 21-CA-005589-O #34**  
**HOLIDAY INN CLUB VACATIONS INCORPORATED**  
**Plaintiff, vs.**  
**ARANEDA CRUZ ET.AL.,**  
**Defendant(s).**

NOTICE OF ACTION  
Count III

To: JO ANN BONNER AND ANY AND ALL UNKNOWN HEIRS, DEVISEES AND OTHER CLAIMANTS OF JO ANN BONNER

And all parties claiming interest by, through, under or against Defendant(s) JO ANN BONNER AND ANY AND ALL UNKNOWN HEIRS, DEVISEES AND OTHER CLAIMANTS OF JO ANN BONNER and all parties having or claiming to have any right, title or interest in the property herein described:

YOU ARE NOTIFIED that an action to foreclose a mortgage/claim of lien on the following described property:

STANDARD Interest(s) in the Orange Lake Land Trust ("Trust") evidenced for administrative, assessment and ownership purposes by 300000 points, which Trust was created pursuant to and further described in that certain Trust Agreement for Orange Lake Land Trust dated December 15, 2017, executed by and among Chicago Title Timeshare Land Trust, Inc., a Florida Corporation, as the trustee of the Trust, Holiday Inn Club Vacations Incorporated, a Delaware corporation, f/k/a Orange Lake Country Club, Inc., a Delaware corporation, and Orange Lake Trust Owners' Association, Inc., a Florida not-for-profit corporation, as such agreement may be amended and supplemented from time to time ("Trust Agreement"), a memorandum of which is recorded in Official Records Document Number:

SECOND INSERTION

20180061276, Public Records of Orange County, Florida ("Memorandum of Trust")All of the terms, restrictions, covenants, conditions and provisions contained in the Declaration and any amendments thereto, are incorporated herein by reference with the same effect as though fully set forth herein.

has been filed against you and you are required to serve a copy of your written defenses, if any, to it on Jerry E. Aron, Plaintiff's attorney, whose address is 2505 Metrocentre Blvd., Suite 301, West Palm Beach, Florida, 33407, within thirty (30) days after the first publication of this Notice, and file the original with the Clerk of this Court either before service on Plaintiff's attorney or immediately thereafter, otherwise a default will be entered against you for the relief demanded in the Complaint.

If you are a person with disability who needs any accommodation in order to participate in a court proceeding or event, you are entitled, at no cost to you, to the provision of certain assistance. Please contact: in Orange County, ADA Coordinator, Human Resources, Orange County Courthouse, 425 N. Orange Avenue, Suite 510, Orlando, Florida, (407) 836-2303, fax: 407-836-2204; at least 7 days before your scheduled court appearance, or immediately upon receiving notification if the time before the scheduled court appearance is less than 7 days. If you are hearing or voice impaired, call 711 to reach the Telecommunications Relay Service.

TIFFANY MOORE RUSSELL  
CLERK OF THE CIRCUIT COURT  
ORANGE COUNTY, FLORIDA  
(10/14/2021)  
/s/ Nancy Garcia  
DEPUTY CLERK  
425 North Orange Ave.  
Suite 350  
Orlando, Florida 32801  
September 2, 9, 2021 21-03069W

SECOND INSERTION

IN THE CIRCUIT COURT, IN AND FOR ORANGE COUNTY, FLORIDA.

**CASE NO.: 21-CA-005642-O #40**  
**HOLIDAY INN CLUB VACATIONS INCORPORATED**  
**Plaintiff, vs.**  
**MONTANO ANGULO ET.AL.,**  
**Defendant(s).**

NOTICE OF ACTION  
Count VIII

To: RICKY LEE PENCE AND ANY AND ALL UNKNOWN HEIRS, DEVISEES AND OTHER CLAIMANTS OF RICKY LEE PENCE

And all parties claiming interest by, through, under or against Defendant(s) RICKY LEE PENCE AND ANY AND ALL UNKNOWN HEIRS, DEVISEES AND OTHER CLAIMANTS OF RICKY LEE PENCE and all parties having or claiming to have any right, title or interest in the property herein described:

YOU ARE NOTIFIED that an action to foreclose a mortgage/claim of lien on the following described property:

STANDARD Interest(s) in the Orange Lake Land Trust ("Trust") evidenced for administrative, assessment and ownership purposes by 125000 points, which Trust was created pursuant to and further described in that certain Trust Agreement for Orange Lake Land Trust dated December 15, 2017, executed by and among Chicago Title Timeshare Land Trust, Inc., a Florida Corporation, as the trustee of the Trust, Holiday Inn Club Vacations Incorporated, a Delaware corporation, f/k/a Orange Lake Country Club, Inc., a Delaware corporation, and Orange Lake Trust Owners' Association, Inc., a Florida not-for-profit corporation, as such agreement may be amended and supplemented from time to time ("Trust Agreement"), a memorandum of which is recorded in Official

Records Document Number: 20180061276, Public Records of Orange County, Florida ("Memorandum of Trust")All of the terms, restrictions, covenants, conditions and provisions contained in the Declaration and any amendments thereto, are incorporated herein by reference with the same effect as though fully set forth herein.

has been filed against you and you are required to serve a copy of your written defenses, if any, to it on Jerry E. Aron, Plaintiff's attorney, whose address is 2505 Metrocentre Blvd., Suite 301, West Palm Beach, Florida, 33407, within thirty (30) days after the first publication of this Notice, and file the original with the Clerk of this Court either before service on Plaintiff's attorney or immediately thereafter, otherwise a default will be entered against you for the relief demanded in the Complaint.

If you are a person with disability who needs any accommodation in order to participate in a court proceeding or event, you are entitled, at no cost to you, to the provision of certain assistance. Please contact: in Orange County, ADA Coordinator, Human Resources, Orange County Courthouse, 425 N. Orange Avenue, Suite 510, Orlando, Florida, (407) 836-2303, fax: 407-836-2204; at least 7 days before your scheduled court appearance, or immediately upon receiving notification if the time before the scheduled court appearance is less than 7 days. If you are hearing or voice impaired, call 711 to reach the Telecommunications Relay Service.

August 23rd, 2021  
TIFFANY MOORE RUSSELL  
CLERK OF THE CIRCUIT COURT  
ORANGE COUNTY, FLORIDA  
/s/ Liz Yanira Gordian Olmo  
Deputy Clerk  
425 North Orange Ave.  
Suite 350  
Orlando, Florida 32801  
September 2, 9, 2021 21-03199W

SECOND INSERTION

IN THE CIRCUIT COURT, IN AND FOR ORANGE COUNTY, FLORIDA.

**CASE NO.: 21-CA-005642-O #40**  
**HOLIDAY INN CLUB VACATIONS INCORPORATED**  
**Plaintiff, vs.**  
**MONTANO ANGULO ET.AL.,**  
**Defendant(s).**

NOTICE OF ACTION  
Count I

To: ALBERTO GUILLERMO MONTANO ANGULO and JENNY KARINA NAZARENO ALEGRIA MARTHA ISABEL MONTANO NAZARENO AND all parties claiming interest by, through, under or against Defendant(s) ALBERTO GUILLERMO MONTANO ANGULO and JENNY KARINA NAZARENO ALEGRIA

MARTHA ISABEL MONTANO NAZARENO and all parties having or claiming to have any right, title or interest in the property herein described:

YOU ARE NOTIFIED that an action to foreclose a mortgage/claim of lien on the following described property:

STANDARD Interest(s) in the Orange Lake Land Trust ("Trust") evidenced for administrative, assessment and ownership purposes by 300000 points, which Trust was created pursuant to and further described in that certain Trust Agreement for Orange Lake Land Trust dated December 15, 2017, executed by and among Chicago Title Timeshare Land Trust, Inc., a Florida Corporation, as the trustee of the Trust, Holiday Inn Club Vacations Incorporated, a Delaware corporation, f/k/a Orange Lake Country Club, Inc., a Delaware corporation, and Orange Lake Trust Owners' Association, Inc., a Florida not-for-profit corporation, as such agreement may be amended and supplemented from time to time ("Trust Agreement"), a memorandum of which is recorded in Official

SECOND INSERTION

Records Document Number: 20180061276, Public Records of Orange County, Florida ("Memorandum of Trust")All of the terms, restrictions, covenants, conditions and provisions contained in the Declaration and any amendments thereto, are incorporated herein by reference with the same effect as though fully set forth herein.

has been filed against you and you are required to serve a copy of your written defenses, if any, to it on Jerry E. Aron, Plaintiff's attorney, whose address is 2505 Metrocentre Blvd., Suite 301, West Palm Beach, Florida, 33407, within thirty (30) days after the first publication of this Notice, and file the original with the Clerk of this Court either before service on Plaintiff's attorney or immediately thereafter, otherwise a default will be entered against you for the relief demanded in the Complaint.

If you are a person with disability who needs any accommodation in order to participate in a court proceeding or event, you are entitled, at no cost to you, to the provision of certain assistance. Please contact: in Orange County, ADA Coordinator, Human Resources, Orange County Courthouse, 425 N. Orange Avenue, Suite 510, Orlando, Florida, (407) 836-2303, fax: 407-836-2204; at least 7 days before your scheduled court appearance, or immediately upon receiving notification if the time before the scheduled court appearance is less than 7 days. If you are hearing or voice impaired, call 711 to reach the Telecommunications Relay Service.

August 23rd, 2021  
TIFFANY MOORE RUSSELL  
CLERK OF THE CIRCUIT COURT  
ORANGE COUNTY, FLORIDA  
/s/ Liz Yanira Gordian Olmo  
Deputy Clerk  
425 North Orange Ave.  
Suite 350  
Orlando, Florida 32801  
September 2, 9, 2021 21-03192W

SECOND INSERTION

IN THE CIRCUIT COURT, IN AND FOR ORANGE COUNTY, FLORIDA.

**CASE NO.: 21-CA-005647-O #37**  
**HOLIDAY INN CLUB VACATIONS INCORPORATED**  
**Plaintiff, vs.**  
**SMALL ET.AL.,**  
**Defendant(s).**

NOTICE OF ACTION  
Count X

To: ANTHONY JEROME WILLIAMS AND ANY AND ALL UNKNOWN HEIRS, DEVISEES AND OTHER CLAIMANTS OF ANTHONY JEROME WILLIAMS

And all parties claiming interest by, through, under or against Defendant(s) ANTHONY JEROME WILLIAMS AND ANY AND ALL UNKNOWN HEIRS, DEVISEES AND OTHER CLAIMANTS OF ANTHONY JEROME WILLIAMS and all parties having or claiming to have any right, title or interest in the property herein described:

YOU ARE NOTIFIED that an action to foreclose a mortgage/claim of lien on the following described property:

STANDARD Interest(s) in the Orange Lake Land Trust ("Trust") evidenced for administrative, assessment and ownership purposes by 100000 points, which Trust was created pursuant to and further described in that certain Trust Agreement for Orange Lake Land Trust dated December 15, 2017, executed by and among Chicago Title Timeshare Land Trust, Inc., a Florida Corporation, as the trustee of the Trust, Holiday Inn Club Vacations Incorporated, a Delaware corporation, f/k/a Orange Lake Country Club, Inc., a Delaware corporation, and Orange Lake Trust Owners' Association, Inc., a Florida not-for-profit corporation, as such agreement may be amended and supplemented from time to time ("Trust

SECOND INSERTION

Agreement"), a memorandum of which is recorded in Official Records Document Number: 20180061276, Public Records of Orange County, Florida ("Memorandum of Trust")All of the terms, restrictions, covenants, conditions and provisions contained in the Declaration and any amendments thereto, are incorporated herein by reference with the same effect as though fully set forth herein.

has been filed against you and you are required to serve a copy of your written defenses, if any, to it on Jerry E. Aron, Plaintiff's attorney, whose address is 2505 Metrocentre Blvd., Suite 301, West Palm Beach, Florida, 33407, within thirty (30) days after the first publication of this Notice, and file the original with the Clerk of this Court either before service on Plaintiff's attorney or immediately thereafter, otherwise a default will be entered against you for the relief demanded in the Complaint.

If you are a person with disability who needs any accommodation in order to participate in a court proceeding or event, you are entitled, at no cost to you, to the provision of certain assistance. Please contact: in Orange County, ADA Coordinator, Human Resources, Orange County Courthouse, 425 N. Orange Avenue, Suite 510, Orlando, Florida, (407) 836-2303, fax: 407-836-2204; at least 7 days before your scheduled court appearance, or immediately upon receiving notification if the time before the scheduled court appearance is less than 7 days. If you are hearing or voice impaired, call 711 to reach the Telecommunications Relay Service.

TIFFANY MOORE RUSSELL  
CLERK OF THE CIRCUIT COURT  
ORANGE COUNTY, FLORIDA  
/s/ Stan Green, Deputy Clerk  
425 North Orange Ave.  
Suite 350  
Orlando, Florida 32801  
September 2, 9, 2021 21-03175W

**ORANGE COUNTY  
SUBSEQUENT INSERTIONS**

**SECOND INSERTION**

IN THE CIRCUIT COURT, IN AND FOR ORANGE COUNTY, FLORIDA.  
**CASE NO.: 21-CA-006290-O #39 HOLIDAY INN CLUB VACATIONS INCORPORATED Plaintiff, vs. MARCELIN ET.AL., Defendant(s).**  
NOTICE OF ACTION  
Count I  
To: JEAN HUBERT MARCELIN and NADINE DENISE PAYEN AND ANY AND ALL UNKNOWN HEIRS, DEVISEES AND OTHER CLAIMANTS OF NADINE DENISE PAYEN  
And all parties claiming interest by, through, under or against Defendant(s) JEAN HUBERT MARCELIN and NADINE DENISE PAYEN AND ANY AND ALL UNKNOWN HEIRS, DEVISEES AND OTHER CLAIMANTS OF NADINE DENISE PAYEN and all parties having or claiming to have any right, title or interest in the property herein described:  
YOU ARE NOTIFIED that an action to foreclose a mortgage/claim of lien on the following described property in Orange County, Florida:  
WEEK/UNIT:  
46 ODD/87557  
of Orange Lake Country Club

Villas III, a Condominium, together with an undivided interest in the common elements appurtenant thereto, according to the Declaration of Condominium thereof recorded in Official Records Book 5914, Page 1965, in the Public Records of Orange County, Florida, and all amendments thereto; the plat of which is recorded in Condominium Book 28, page 84-92 until 12:00 noon on the first Saturday 2071, at which date said estate shall terminate; TOGETHER with a remainder over in fee simple absolute as tenant in common with the other owners of all the unit weeks in the above described Condominium in the percentage interest established in the Declaration of Condominium.  
has been filed against you and you are required to serve a copy of your written defenses, if any, to it on Jerry E. Aron, Plaintiff's attorney, whose address is 2505 Metrocentre Blvd., Suite 301, West Palm Beach, Florida, 33407, within thirty (30) days after the first publication of this Notice, and file the original with the Clerk of this

Court either before service on Plaintiff's attorney or immediately thereafter, otherwise a default will be entered against you for the relief demanded in the Complaint.  
If you are a person with disability who needs any accommodation in order to participate in a court proceeding or event, you are entitled, at no cost to you, to the provision of certain assistance. Please contact: in Orange County, ADA Coordinator, Human Resources, Orange County Courthouse, 425 N. Orange Avenue, Suite 510, Orlando, Florida, (407) 836-2303, fax: 407-836-2204; at least 7 days before your scheduled court appearance, or immediately upon receiving notification if the time before the scheduled court appearance is less than 7 days. If you are hearing or voice impaired, call 711 to reach the Telecommunications Relay Service.  
(10/14/2021)  
TIFFANY MOORE RUSSELL  
CLERK OF THE CIRCUIT COURT  
ORANGE COUNTY, FLORIDA  
/s/ Nancy Garcia, 8/19/2021  
Deputy Clerk  
425 North Orange Ave.  
Suite 350  
Orlando, Florida 32801  
September 2, 9, 2021 21-03181W

IN THE CIRCUIT COURT, IN AND FOR ORANGE COUNTY, FLORIDA.  
**CASE NO.: 21-CA-006287-O #33 HOLIDAY INN CLUB VACATIONS INCORPORATED Plaintiff, vs. PAOLETTI ET.AL., Defendant(s).**  
NOTICE OF ACTION  
Count I  
To: ANAGALY PAOLETTI and JOSE LUIS RAMOS ROMAN AND ANY AND ALL UNKNOWN HEIRS, DEVISEES AND OTHER CLAIMANTS OF JOSE LUIS RAMOS ROMAN  
And all parties claiming interest by, through, under or against Defendant(s) ANAGALY PAOLETTI and JOSE LUIS RAMOS ROMAN AND ANY AND ALL UNKNOWN HEIRS, DEVISEES AND OTHER CLAIMANTS OF JOSE LUIS RAMOS ROMAN and all parties having or claiming to have any right, title or interest in the property herein described:  
YOU ARE NOTIFIED that an action to foreclose a mortgage/claim of lien on the following described property in Orange County, Florida:  
WEEK/UNIT:  
1 EVEN/87912  
of Orange Lake Country Club

Villas III, a Condominium, together with an undivided interest in the common elements appurtenant thereto, according to the Declaration of Condominium thereof recorded in Official Records Book 5914, Page 1965, in the Public Records of Orange County, Florida, and all amendments thereto; the plat of which is recorded in Condominium Book 28, page 84-92 until 12:00 noon on the first Saturday 2071, at which date said estate shall terminate; TOGETHER with a remainder over in fee simple absolute as tenant in common with the other owners of all the unit weeks in the above described Condominium in the percentage interest established in the Declaration of Condominium.  
has been filed against you and you are required to serve a copy of your written defenses, if any, to it on Jerry E. Aron, Plaintiff's attorney, whose address is 2505 Metrocentre Blvd., Suite 301, West Palm Beach, Florida, 33407, within thirty (30) days after the first publication of this Notice, and file the original with the Clerk of this

Court either before service on Plaintiff's attorney or immediately thereafter, otherwise a default will be entered against you for the relief demanded in the Complaint.  
If you are a person with disability who needs any accommodation in order to participate in a court proceeding or event, you are entitled, at no cost to you, to the provision of certain assistance. Please contact: in Orange County, ADA Coordinator, Human Resources, Orange County Courthouse, 425 N. Orange Avenue, Suite 510, Orlando, Florida, (407) 836-2303, fax: 407-836-2204; at least 7 days before your scheduled court appearance, or immediately upon receiving notification if the time before the scheduled court appearance is less than 7 days. If you are hearing or voice impaired, call 711 to reach the Telecommunications Relay Service.  
TIFFANY MOORE RUSSELL  
CLERK OF THE CIRCUIT COURT  
ORANGE COUNTY, FLORIDA  
08/19/2021  
/s/ RAMONA VELEZ,  
DEPUTY CLERK  
425 North Orange Ave.  
Suite 350  
Orlando, Florida 32801  
September 2, 9, 2021 21-03041W

**SECOND INSERTION**

IN THE CIRCUIT COURT, IN AND FOR ORANGE COUNTY, FLORIDA.  
**CASE NO.: 21-CA-005646-O #33 HOLIDAY INN CLUB VACATIONS INCORPORATED Plaintiff, vs. SAWH ET.AL., Defendant(s).**  
NOTICE OF ACTION  
Count VIII  
To: LUIS ALBERTO SANCHEZ MONTES DE OCA and ROSA MARIA FERNANDEZ DAVILA GONZALES and CARLOS ALBERTO SANCHEZ FERNANDEZ-DAVILA  
And all parties claiming interest by, through, under or against Defendant(s) LUIS ALBERTO SANCHEZ MONTES DE OCA and ROSA MARIA FERNANDEZ DAVILA GONZALES and CARLOS ALBERTO SANCHEZ FERNANDEZ-DAVILA and all parties having or claiming to have any right, title or interest in the property herein described.  
YOU ARE NOTIFIED that an action to foreclose a mortgage/claim of lien on the following described property :  
STANDARD Interest(s) in the Orange Lake Land Trust ("Trust") evidenced for administrative, assessment and ownership purposes by 100000 points, which Trust was created pursuant to and further described in that certain Trust Agreement for Orange Lake Land Trust dated December 15, 2017, executed by and among Chicago Title Timeshare Land Trust, Inc., a Florida Corporation, as the trustee of the Trust, Holiday Inn Club Vacations Incorporated, a Delaware corporation, f/k/a Orange Lake Country Club, Inc., a Delaware corporation, and Orange Lake Trust Owners' Association, Inc., a Florida not-for-profit corporation, as such agreement may be amended and supplemented from time to time ("Trust Agreement"), a memorandum

of which is recorded in Official Records Document Number: 20180061276, Public Records of Orange County, Florida ("Memorandum of Trust")All of the terms, restrictions, covenants, conditions and provisions contained in the Declaration and any amendments thereto, are incorporated herein by reference with the same effect as though fully set forth herein.  
has been filed against you and you are required to serve a copy of your written defenses, if any, to it on Jerry E. Aron, Plaintiff's attorney, whose address is 2505 Metrocentre Blvd., Suite 301, West Palm Beach, Florida, 33407, within thirty (30) days after the first publication of this Notice, and file the original with the Clerk of this Court either before service on Plaintiff's attorney or immediately thereafter, otherwise a default will be entered against you for the relief demanded in the Complaint.  
If you are a person with disability who needs any accommodation in order to participate in a court proceeding or event, you are entitled, at no cost to you, to the provision of certain assistance. Please contact: in Orange County, ADA Coordinator, Human Resources, Orange County Courthouse, 425 N. Orange Avenue, Suite 510, Orlando, Florida, (407) 836-2303, fax: 407-836-2204; at least 7 days before your scheduled court appearance, or immediately upon receiving notification if the time before the scheduled court appearance is less than 7 days. If you are hearing or voice impaired, call 711 to reach the Telecommunications Relay Service.  
TIFFANY MOORE RUSSELL  
CLERK OF THE CIRCUIT COURT  
ORANGE COUNTY, FLORIDA  
08/19/2021  
/s/ Lisa Geib  
425 North Orange Ave.  
Suite 350  
Orlando, Florida 32801  
September 2, 9, 2021 21-03056W

IN THE CIRCUIT COURT, IN AND FOR ORANGE COUNTY, FLORIDA.  
**CASE NO.: 21-CA-005646-O #33 HOLIDAY INN CLUB VACATIONS INCORPORATED Plaintiff, vs. SAWH ET.AL., Defendant(s).**  
NOTICE OF ACTION  
Count V  
To: PAMELA ANN RUSSELL AND ANY AND ALL UNKNOWN HEIRS, DEVISEES AND OTHER CLAIMANTS OF PAMELA ANN RUSSELL  
And all parties claiming interest by, through, under or against Defendant(s) PAMELA ANN RUSSELL AND ANY AND ALL UNKNOWN HEIRS, DEVISEES AND OTHER CLAIMANTS OF PAMELA ANN RUSSELL and all parties having or claiming to have any right, title or interest in the property herein described.  
YOU ARE NOTIFIED that an action to foreclose a mortgage/claim of lien on the following described property :  
STANDARD Interest(s) in the Orange Lake Land Trust ("Trust") evidenced for administrative, assessment and ownership purposes by 45000 points, which Trust was created pursuant to and further described in that certain Trust Agreement for Orange Lake Land Trust dated December 15, 2017, executed by and among Chicago Title Timeshare Land Trust, Inc., a Florida Corporation, as the trustee of the Trust, Holiday Inn Club Vacations Incorporated, a Delaware corporation, f/k/a Orange Lake Country Club, Inc., a Delaware corporation, and Orange Lake Trust Owners' Association, Inc., a Florida not-for-profit corporation, as such agreement may be amended and supplemented from time to time ("Trust Agreement"), a memorandum

of which is recorded in Official Records Document Number: 20180061276, Public Records of Orange County, Florida ("Memorandum of Trust")All of the terms, restrictions, covenants, conditions and provisions contained in the Declaration and any amendments thereto, are incorporated herein by reference with the same effect as though fully set forth herein.  
has been filed against you and you are required to serve a copy of your written defenses, if any, to it on Jerry E. Aron, Plaintiff's attorney, whose address is 2505 Metrocentre Blvd., Suite 301, West Palm Beach, Florida, 33407, within thirty (30) days after the first publication of this Notice, and file the original with the Clerk of this Court either before service on Plaintiff's attorney or immediately thereafter, otherwise a default will be entered against you for the relief demanded in the Complaint.  
If you are a person with disability who needs any accommodation in order to participate in a court proceeding or event, you are entitled, at no cost to you, to the provision of certain assistance. Please contact: in Orange County, ADA Coordinator, Human Resources, Orange County Courthouse, 425 N. Orange Avenue, Suite 510, Orlando, Florida, (407) 836-2303, fax: 407-836-2204; at least 7 days before your scheduled court appearance, or immediately upon receiving notification if the time before the scheduled court appearance is less than 7 days. If you are hearing or voice impaired, call 711 to reach the Telecommunications Relay Service.  
TIFFANY MOORE RUSSELL  
CLERK OF THE CIRCUIT COURT  
ORANGE COUNTY, FLORIDA  
08/19/2021  
/s/ Lisa Geib  
425 North Orange Ave.  
Suite 350  
Orlando, Florida 32801  
September 2, 9, 2021 21-03053W

IN THE CIRCUIT COURT, IN AND FOR ORANGE COUNTY, FLORIDA.  
**CASE NO.: 21-CA-006283-O #35 HOLIDAY INN CLUB VACATIONS INCORPORATED Plaintiff, vs. ALI AKBARI ET.AL., Defendant(s).**  
NOTICE OF ACTION  
Count VII  
To: FRANCISCO JAVIER CEVALLOS SANCHEZ and FERNANDA PAULINA ESPINOZA AGUILAR  
And all parties claiming interest by, through, under or against Defendant(s) FRANCISCO JAVIER CEVALLOS SANCHEZ and FERNANDA PAULINA ESPINOZA AGUILAR and all parties having or claiming to have any right, title or interest in the property herein described.  
YOU ARE NOTIFIED that an action to foreclose a mortgage/claim of lien on the following described property :  
STANDARD Interest(s) in the Orange Lake Land Trust ("Trust") evidenced for administrative, assessment and ownership purposes by 30000 points, which Trust was created pursuant to and further described in that certain Trust Agreement for Orange Lake Land Trust dated December 15, 2017, executed by and among Chicago Title Timeshare Land Trust, Inc., a Florida Corporation, as the trustee of the Trust, Holiday Inn Club Vacations Incorporated, a Delaware corporation, f/k/a Orange Lake Country Club, Inc., a Delaware corporation, and Orange Lake Trust Owners' Association, Inc., a Florida not-for-profit corporation, as such agreement may be amended and supplemented from time to time ("Trust Agreement"), a memorandum of which is recorded in Official Records Document Number: 20180061276, Public Records of

Orange County, Florida ("Memorandum of Trust")All of the terms, restrictions, covenants, conditions and provisions contained in the Declaration and any amendments thereto, are incorporated herein by reference with the same effect as though fully set forth herein.  
has been filed against you and you are required to serve a copy of your written defenses, if any, to it on Jerry E. Aron, Plaintiff's attorney, whose address is 2505 Metrocentre Blvd., Suite 301, West Palm Beach, Florida, 33407, within thirty (30) days after the first publication of this Notice, and file the original with the Clerk of this Court either before service on Plaintiff's attorney or immediately thereafter, otherwise a default will be entered against you for the relief demanded in the Complaint.  
If you are a person with disability who needs any accommodation in order to participate in a court proceeding or event, you are entitled, at no cost to you, to the provision of certain assistance. Please contact: in Orange County, ADA Coordinator, Human Resources, Orange County Courthouse, 425 N. Orange Avenue, Suite 510, Orlando, Florida, (407) 836-2303, fax: 407-836-2204; at least 7 days before your scheduled court appearance, or immediately upon receiving notification if the time before the scheduled court appearance is less than 7 days. If you are hearing or voice impaired, call 711 to reach the Telecommunications Relay Service.  
TIFFANY MOORE RUSSELL  
CLERK OF THE CIRCUIT COURT  
ORANGE COUNTY, FLORIDA  
8/19/2021  
/s/ Lisa Geib  
DEPUTY CLERK  
425 North Orange Ave.  
Suite 350  
Orlando, Florida 32801  
September 2, 9, 2021 21-03089W

**SECOND INSERTION**

IN THE CIRCUIT COURT, IN AND FOR ORANGE COUNTY, FLORIDA.  
**CASE NO.: 21-CA-006285-O #36 HOLIDAY INN CLUB VACATIONS INCORPORATED Plaintiff, vs. MOHAMED ELSANGEDY ET.AL., Defendant(s).**  
NOTICE OF ACTION  
Count II  
To: PRISCILLA D. MYERS AND ANY AND ALL UNKNOWN HEIRS, DEVISEES AND OTHER CLAIMANTS OF PRISCILLA D. MYERS  
And all parties claiming interest by, through, under or against Defendant(s) PRISCILLA D. MYERS AND ANY AND ALL UNKNOWN HEIRS, DEVISEES AND OTHER CLAIMANTS OF PRISCILLA D. MYERS and all parties having or claiming to have any right, title or interest in the property herein described.  
YOU ARE NOTIFIED that an action to foreclose a mortgage/claim of lien on the following described property :  
STANDARD Interest(s) in the Orange Lake Land Trust ("Trust") evidenced for administrative, assessment and ownership purposes by 50000 points, which Trust was created pursuant to and further described in that certain Trust Agreement for Orange Lake Land Trust dated December 15, 2017, executed by and among Chicago Title Timeshare Land Trust, Inc., a Florida Corporation, as the trustee of the Trust, Holiday Inn Club Vacations Incorporated, a Delaware corporation, f/k/a Orange Lake Country Club, Inc., a Delaware corporation, and Orange Lake Trust Owners' Association, Inc., a Florida not-for-profit corporation, as such agreement may be amended and supplemented from time to time ("Trust Agreement"), a memorandum of which is recorded in Official

Records Document Number: 20180061276, Public Records of Orange County, Florida ("Memorandum of Trust")All of the terms, restrictions, covenants, conditions and provisions contained in the Declaration and any amendments thereto, are incorporated herein by reference with the same effect as though fully set forth herein.  
has been filed against you and you are required to serve a copy of your written defenses, if any, to it on Jerry E. Aron, Plaintiff's attorney, whose address is 2505 Metrocentre Blvd., Suite 301, West Palm Beach, Florida, 33407, within thirty (30) days after the first publication of this Notice, and file the original with the Clerk of this Court either before service on Plaintiff's attorney or immediately thereafter, otherwise a default will be entered against you for the relief demanded in the Complaint.  
If you are a person with disability who needs any accommodation in order to participate in a court proceeding or event, you are entitled, at no cost to you, to the provision of certain assistance. Please contact: in Orange County, ADA Coordinator, Human Resources, Orange County Courthouse, 425 N. Orange Avenue, Suite 510, Orlando, Florida, (407) 836-2303, fax: 407-836-2204; at least 7 days before your scheduled court appearance, or immediately upon receiving notification if the time before the scheduled court appearance is less than 7 days. If you are hearing or voice impaired, call 711 to reach the Telecommunications Relay Service.  
TIFFANY MOORE RUSSELL  
CLERK OF THE CIRCUIT COURT  
ORANGE COUNTY, FLORIDA  
August 23rd, 2021  
/s/ Liz Yanira Gordian Olmo  
DEPUTY CLERK  
425 North Orange Ave.  
Suite 350  
Orlando, Florida 32801  
September 2, 9, 2021 21-03141W

IN THE CIRCUIT COURT, IN AND FOR ORANGE COUNTY, FLORIDA.  
**CASE NO.: 21-CA-005589-O #34 HOLIDAY INN CLUB VACATIONS INCORPORATED Plaintiff, vs. ARANEDA CRUZ ET.AL., Defendant(s).**  
NOTICE OF ACTION  
Count XI  
To: TIFFANY NICOLE MANER AND ANY AND ALL UNKNOWN HEIRS, DEVISEES AND OTHER CLAIMANTS OF TIFFANY NICOLE MANER  
And all parties claiming interest by, through, under or against Defendant(s) TIFFANY NICOLE MANER AND ANY AND ALL UNKNOWN HEIRS, DEVISEES AND OTHER CLAIMANTS OF TIFFANY NICOLE MANER and all parties having or claiming to have any right, title or interest in the property herein described.  
YOU ARE NOTIFIED that an action to foreclose a mortgage/claim of lien on the following described property :  
STANDARD Interest(s) in the Orange Lake Land Trust ("Trust") evidenced for administrative, assessment and ownership purposes by 100000 points, which Trust was created pursuant to and further described in that certain Trust Agreement for Orange Lake Land Trust dated December 15, 2017, executed by and among Chicago Title Timeshare Land Trust, Inc., a Florida Corporation, as the trustee of the Trust, Holiday Inn Club Vacations Incorporated, a Delaware corporation, f/k/a Orange Lake Country Club, Inc., a Delaware corporation, and Orange Lake Trust Owners' Association, Inc., a Florida not-for-profit corporation, as such agreement may be amended and supplemented from time to time ("Trust Agreement"), a memorandum of which is recorded in Official

Records Document Number: 20180061276, Public Records of Orange County, Florida ("Memorandum of Trust")All of the terms, restrictions, covenants, conditions and provisions contained in the Declaration and any amendments thereto, are incorporated herein by reference with the same effect as though fully set forth herein.  
has been filed against you and you are required to serve a copy of your written defenses, if any, to it on Jerry E. Aron, Plaintiff's attorney, whose address is 2505 Metrocentre Blvd., Suite 301, West Palm Beach, Florida, 33407, within thirty (30) days after the first publication of this Notice, and file the original with the Clerk of this Court either before service on Plaintiff's attorney or immediately thereafter, otherwise a default will be entered against you for the relief demanded in the Complaint.  
(10/14/2021)  
If you are a person with disability who needs any accommodation in order to participate in a court proceeding or event, you are entitled, at no cost to you, to the provision of certain assistance. Please contact: in Orange County, ADA Coordinator, Human Resources, Orange County Courthouse, 425 N. Orange Avenue, Suite 510, Orlando, Florida, (407) 836-2303, fax: 407-836-2204; at least 7 days before your scheduled court appearance, or immediately upon receiving notification if the time before the scheduled court appearance is less than 7 days. If you are hearing or voice impaired, call 711 to reach the Telecommunications Relay Service.  
TIFFANY MOORE RUSSELL  
CLERK OF THE CIRCUIT COURT  
ORANGE COUNTY, FLORIDA  
/s/ Nancy Garcia  
DEPUTY CLERK  
425 North Orange Ave.  
Suite 350  
Orlando, Florida 32801  
September 2, 9, 2021 21-03076W

IN THE CIRCUIT COURT, IN AND FOR ORANGE COUNTY, FLORIDA.  
**CASE NO.: 21-CA-005644-O #35 HOLIDAY INN CLUB VACATIONS INCORPORATED Plaintiff, vs. NAVARRO MOLINA ET.AL., Defendant(s).**  
NOTICE OF ACTION  
Count VI  
To: IVAN ALEJANDRO ORDENES ORDENES and MONICA DEL ROSARIO HERNANDEZ BUSTAMANTE and ALEJANDRA DEL ROSARIO ORDENES HERNANDEZ  
And all parties claiming interest by, through, under or against Defendant(s) IVAN ALEJANDRO ORDENES ORDENES and MONICA DEL ROSARIO HERNANDEZ BUSTAMANTE ALEJANDRA DEL ROSARIO ORDENES HERNANDEZ and all parties having or claiming to have any right, title or interest in the property herein described.  
YOU ARE NOTIFIED that an action to foreclose a mortgage/claim of lien on the following described property :  
STANDARD Interest(s) in the Orange Lake Land Trust ("Trust") evidenced for administrative, assessment and ownership purposes by 100000 points, which Trust was created pursuant to and further described in that certain Trust Agreement for Orange Lake Land Trust dated December 15, 2017, executed by and among Chicago Title Timeshare Land Trust, Inc., a Florida Corporation, as the trustee of the Trust, Holiday Inn Club Vacations Incorporated, a Delaware corporation, f/k/a Orange Lake Country Club, Inc., a Delaware corporation, and Orange Lake Trust Owners' Association, Inc., a Florida not-for-profit corporation, as such agreement may be amended and supplemented from time to time ("Trust Agreement"), a memorandum

of which is recorded in Official Records Document Number: 20180061276, Public Records of Orange County, Florida ("Memorandum of Trust")All of the terms, restrictions, covenants, conditions and provisions contained in the Declaration and any amendments thereto, are incorporated herein by reference with the same effect as though fully set forth herein.  
has been filed against you and you are required to serve a copy of your written defenses, if any, to it on Jerry E. Aron, Plaintiff's attorney, whose address is 2505 Metrocentre Blvd., Suite 301, West Palm Beach, Florida, 33407, within thirty (30) days after the first publication of this Notice, and file the original with the Clerk of this Court either before service on Plaintiff's attorney or immediately thereafter, otherwise a default will be entered against you for the relief demanded in the Complaint.  
If you are a person with disability who needs any accommodation in order to participate in a court proceeding or event, you are entitled, at no cost to you, to the provision of certain assistance. Please contact: in Orange County, ADA Coordinator, Human Resources, Orange County Courthouse, 425 N. Orange Avenue, Suite 510, Orlando, Florida, (407) 836-2303, fax: 407-836-2204; at least 7 days before your scheduled court appearance, or immediately upon receiving notification if the time before the scheduled court appearance is less than 7 days. If you are hearing or voice impaired, call 711 to reach the Telecommunications Relay Service.  
TIFFANY MOORE RUSSELL  
CLERK OF THE CIRCUIT COURT  
ORANGE COUNTY, FLORIDA  
8/19/2021  
/s/ Lisa Geib  
425 North Orange Ave.  
Suite 350  
Orlando, Florida 32801  
September 2, 9, 2021 21-03107W

ORANGE COUNTY
SUBSEQUENT INSERTIONS

SECOND INSERTION

NOTICE OF FORECLOSURE SALE IN THE CIRCUIT COURT OF THE NINTH JUDICIAL CIRCUIT IN AND FOR ORANGE COUNTY, FLORIDA

CASE NO.: 2018-CA-011859-O
PHH MORTGAGE CORPORATION, Plaintiff, v. JOSEPH P. ANDREETTI, ET AL., Defendant(s).

NOTICE IS HEREBY GIVEN pursuant to an Order dated August 11, 2021 entered in Civil Case No. 2018-CA-011859-O in the Circuit Court of the Ninth Judicial Circuit in and for Orange County, Florida, wherein PHH MORTGAGE CORPORATION, Plaintiff and JOSEPH P. ANDREETTI, SHAWN L. ANDREETTI; ERROL ESTATE PROPERTY OWNERS' ASSOCIATION, INC., are defendants, Tiffany Moore Russell, Clerk of Court, will sell the property at public sale at www.myorangeclerk.realforeclose.com beginning at 11:00 AM on September 27, 2021 the following described property as set forth in said Final Judgment,

to-wit:

LOT 1, LEXINGTON CLUB, ACCORDING TO THE PLAT THEREOF AS RECORDED IN PLAT BOOK 22, PAGES 61 AND 62, PUBLIC RECORDS OF ORANGE COUNTY, FLORIDA. Property Address: 1250 Glenmore Drive, Apopka, FL 32712

ANY PERSON CLAIMING AN INTEREST IN THE SURPLUS FROM THE SALE, IF ANY, OTHER THAN THE PROPERTY OWNER AS OF THE DATE OF THE LIS PENDENS MUST FILE A CLAIM BEFORE THE CLERK REPORTS THE SURPLUS AS UNCLAIMED.

THE COURT, IN ITS DISCRETION, MAY ENLARGE THE TIME OF THE SALE. NOTICE OF THE CHANGED TIME OF SALE SHALL BE PUBLISHED AS PROVIDED HEREIN.

IF YOU ARE A PERSON WITH A DISABILITY WHO NEEDS ANY ACCOMMODATION IN ORDER TO PARTICIPATE IN A COURT PROCEEDING OR EVENT, YOU ARE ENTITLED, AT NO COST TO YOU, TO THE PROVISION OF CERTAIN ASSISTANCE. PLEASE CONTACT: ADA COORDINATOR, HUMAN RESOURCES, ORANGE COUNTY COURTHOUSE, 425 N. ORANGE AVENUE, SUITE 510, ORLANDO, FLORIDA, (407) 836-2303, FAX: 407-836-2204; AT LEAST 7 DAYS BEFORE YOUR SCHEDULED COURT APPEARANCE, OR IMMEDIATELY UPON RECEIVING NOIFICATION IF THE TIME BEFORE YOUR SCHEDULED COURT APPEARANCE IS LESS THAN 7 DAYS. IF YOU ARE HEARING IMPAIRED OR VOICE IMPAIRED, CALL 711 TO REACH THE TELECOMMUNICATIONS RELAY SERVICE.

/s/ Jason M. Vanslette
Jason M Vanslette
FBN: 92121

Kelley Kronenberg
10360 West State Road 84
Fort Lauderdale, FL 33324
Phone: (954) 370-9970
Fax: (954) 252-4571
Service E-mail:
filealprop@kelleykronenberg.com
File No: FL20-000108
September 2, 9, 2021 21-03232W

SECOND INSERTION

IN THE CIRCUIT COURT, IN AND FOR ORANGE COUNTY, FLORIDA.

CASE NO.: 21-CA-005639-O #33
HOLIDAY INN CLUB VACATIONS INCORPORATED Plaintiff, vs. COTO ALVARADO ET.AL., Defendant(s).

NOTICE OF ACTION
Count X
To: FERNANDO FERNANDEZ ANDES and FRANCISCA FERNANDEZ-ANDES

And all parties claiming interest by, through, under or against Defendant(s) FERNANDO FERNANDEZ ANDES and FRANCISCA FERNANDEZ-ANDES and all parties having or claiming to have any right, title or interest in the property herein described.

YOU ARE NOTIFIED that an action to foreclose a mortgage/claim of lien on the following described property :

STANDARD Interest(s) in the Orange Lake Land Trust ("Trust") evidenced for administrative, assessment and ownership purposes by 75000 points, which Trust was created pursuant to and further described in that certain Trust Agreement for Orange Lake Land Trust dated December 15, 2017, executed by and among Chicago Title Time-share Land Trust, Inc., a Florida Corporation, as the trustee of the Trust, Holiday Inn Club Vacations Incorporated, a Delaware corporation, f/k/a Orange Lake Country Club, Inc., a Delaware corporation, and Orange Lake Trust Owners' Association, Inc., a Florida not-for-profit corporation, as such agreement may be amended and supplemented from time to time ("Trust Agreement"), a memorandum of which is recorded in Official Records Document Number:

20180061276, Public Records of Orange County, Florida ("Memorandum of Trust")All of the terms, restrictions, covenants, conditions and provisions contained in the Declaration and any amendments thereto, are incorporated herein by reference with the same effect as though fully set forth herein.

has been filed against you and you are required to serve a copy of your written defenses, if any, to it on Jerry E. Aron, Plaintiff's attorney, whose address is 2505 Metrocentre Blvd., Suite 301, West Palm Beach, Florida, 33407, within thirty (30) days after the first publication of this Notice, and file the original with the Clerk of this Court either before service on Plaintiff's attorney or immediately thereafter, otherwise a default will be entered against you for the relief demanded in the Complaint.

If you are a person with disability who needs any accommodation in order to participate in a court proceeding or event, you are entitled, at no cost to you, to the provision of certain assistance. Please contact: in Orange County, ADA Coordinator, Human Resources, Orange County Courthouse, 425 N. Orange Avenue, Suite 510, Orlando, Florida, (407) 836-2303, fax: 407-836-2204; at least 7 days before your scheduled court appearance, or immediately upon receiving notification if the time before the scheduled court appearance is less than 7 days. If you are hearing or voice impaired, call 711 to reach the Telecommunications Relay Service.

TIFFANY MOORE RUSSELL
CLERK OF THE CIRCUIT COURT
ORANGE COUNTY, FLORIDA
(10/14/2021)
/s/ Nancy Garcia, 8/18/2021
DEPUTY CLERK
425 North Orange Ave.
Suite 350
Orlando, Florida 32801
September 2, 9, 2021 21-03031W

SECOND INSERTION

IN THE CIRCUIT COURT, IN AND FOR ORANGE COUNTY, FLORIDA.

CASE NO.: 21-CA-005639-O #33
HOLIDAY INN CLUB VACATIONS INCORPORATED Plaintiff, vs. COTO ALVARADO ET.AL., Defendant(s).

NOTICE OF ACTION
Count IX
To: YURIDIA ESTRADA GUZMAN and JOSE DE JESUS CARREON SANCHEZ

And all parties claiming interest by, through, under or against Defendant(s) YURIDIA ESTRADA GUZMAN and JOSE DE JESUS CARREON SANCHEZ and all parties having or claiming to have any right, title or interest in the property herein described.

YOU ARE NOTIFIED that an action to foreclose a mortgage/claim of lien on the following described property :

STANDARD Interest(s) in the Orange Lake Land Trust ("Trust") evidenced for administrative, assessment and ownership purposes by 40000 points, which Trust was created pursuant to and further described in that certain Trust Agreement for Orange Lake Land Trust dated December 15, 2017, executed by and among Chicago Title Time-share Land Trust, Inc., a Florida Corporation, as the trustee of the Trust, Holiday Inn Club Vacations Incorporated, a Delaware corporation, f/k/a Orange Lake Country Club, Inc., a Delaware corporation, and Orange Lake Trust Owners' Association, Inc., a Florida not-for-profit corporation, as such agreement may be amended and supplemented from time to time ("Trust Agreement"), a memorandum of which is recorded in Official Records Document Number:

AMENDED RE-NOTICE OF FORECLOSURE SALE IN THE CIRCUIT COURT OF THENINTH JUDICIALCIRCUIT, IN AND FOR ORANGE COUNTY, FLORIDA
CASE NO.
2018-CA-004645-O

U.S. BANK NATIONAL ASSOCIATION, AS TRUSTEE FOR GREENPOINT MORTGAGE FUNDING TRUST MORTGAGE PASS-THROUGH CERTIFICATES, Plaintiff, vs. RENE M. CHAVEZ; ROSA CHAVEZ, ET AL.
Defendants
NOTICE IS HEREBY GIVEN pursuant to an Order dated August 12, 2021, and entered in Case No. 2018-CA-004645-O, of the Circuit Court of the Ninth Judicial Circuit in and for ORANGE County, Florida. U.S. BANK NATIONAL ASSOCIATION, AS TRUSTEE FOR GREENPOINT MORTGAGE FUNDING TRUST MORTGAGE PASS-THROUGH CER-

SECOND INSERTION

TIFICATES, SERIES 2006-AR4 (hereafter "Plaintiff"), is Plaintiff and RENE M. CHAVEZ; ROSA CHAVEZ; HERITAGE PLACE PROPERTY OWNERS ASSOCIATION, INC., are defendants. Tiffany M. Russell, Clerk of the Circuit Court for ORANGE County, Florida will sell to the highest and best bidder for cash via the Internet at www.myorangeclerk.realforeclose.com, at 11:00 a.m., on the 15TH day of SEPTEMBER, 2021, the following described property as set forth in said Final Judgment, to wit:

LOT 172, HERITAGE PLACE, ACCORDING TO THE PLAT THEREOF, AS RECORDED IN PLAT BOOK 35, PAGES 106 THROUGH 107, OF THE PUBLIC RECORDS OF ORANGE COUNTY, FLORIDA.

Any person claiming an interest in the surplus from the sale, if any, other than the property owner as of the date of the lis pendens must file a claim before the clerk reports the surplus as unclaimed.

IMPORTANT: In accordance with the Americans with Disabilities Act, If you are a person with a disability who

needs any accommodation in order to participate in a court proceeding or event, you are entitled, at no cost to you, to the provision of certain assistance. Please contact Orange County, ADA Coordinator, Human Resources, Orange County Courthouse, 425 N. Orange Avenue, Suite 510, Orlando, Florida, (407) 836-2303, fax: 407-836-2204; at least 7 days before your scheduled court appearance, or immediately upon receiving notification if the time before the scheduled court appearance is less than 7 days. If you are hearing or voice impaired, call 711 to reach the Telecommunications Relay Service.

Tammi M Calderone, Esq.
Florida Bar #: 84926
Email: TCalderone@vanlawfl.com
VAN NESS LAW FIRM, PLC
1239 E. Newport Center Drive, Suite 110
Deerfield Beach, Florida 33442
Ph: (954) 571-2031
PRIMARY EMAIL:
Pleadings@vanlawfl.com
OC1123-18/tr
September 2, 9, 2021 21-03009W

SECOND INSERTION

SECOND INSERTION

IN THE CIRCUIT COURT, IN AND FOR ORANGE COUNTY, FLORIDA.

CASE NO.: 21-CA-006283-O #35
HOLIDAY INN CLUB VACATIONS INCORPORATED Plaintiff, vs. ALI AKBARI ET.AL., Defendant(s).

NOTICE OF ACTION
Count XI
To: MARCELO DOS SANTOS LIMA and MARTA LUCIA BORGES LIMA

And all parties claiming interest by, through, under or against Defendant(s) MARCELO DOS SANTOS LIMA and MARTA LUCIA BORGES LIMA and all parties having or claiming to have any right, title or interest in the property herein described.

YOU ARE NOTIFIED that an action to foreclose a mortgage/claim of lien on the following described property :

STANDARD Interest(s) in the Orange Lake Land Trust ("Trust") evidenced for administrative, assessment and ownership purposes by 60000 points, which Trust was created pursuant to and further described in that certain Trust Agreement for Orange Lake Land Trust dated December 15, 2017, executed by and among Chicago Title Time-share Land Trust, Inc., a Florida Corporation, as the trustee of the Trust, Holiday Inn Club Vacations Incorporated, a Delaware corporation, f/k/a Orange Lake Country Club, Inc., a Delaware corporation, and Orange Lake Trust Owners' Association, Inc., a Florida not-for-profit corporation, as such agreement may be amended and supplemented from time to time ("Trust Agreement"), a memorandum of which is recorded in Official Records Document Number: 20180061276, Public Records of Orange County, Florida ("Mem-

orandum of Trust")All of the terms, restrictions, covenants, conditions and provisions contained in the Declaration and any amendments thereto, are incorporated herein by reference with the same effect as though fully set forth herein.

has been filed against you and you are required to serve a copy of your written defenses, if any, to it on Jerry E. Aron, Plaintiff's attorney, whose address is 2505 Metrocentre Blvd., Suite 301, West Palm Beach, Florida, 33407, within thirty (30) days after the first publication of this Notice, and file the original with the Clerk of this Court either before service on Plaintiff's attorney or immediately thereafter, otherwise a default will be entered against you for the relief demanded in the Complaint.

If you are a person with disability who needs any accommodation in order to participate in a court proceeding or event, you are entitled, at no cost to you, to the provision of certain assistance. Please contact: in Orange County, ADA Coordinator, Human Resources, Orange County Courthouse, 425 N. Orange Avenue, Suite 510, Orlando, Florida, (407) 836-2303, fax: 407-836-2204; at least 7 days before your scheduled court appearance, or immediately upon receiving notification if the time before the scheduled court appearance is less than 7 days. If you are hearing or voice impaired, call 711 to reach the Telecommunications Relay Service.

TIFFANY MOORE RUSSELL
CLERK OF THE CIRCUIT COURT
ORANGE COUNTY, FLORIDA
8/19/2021
/s/ Lisa Geib
DEPUTY CLERK
425 North Orange Ave.
Suite 350
Orlando, Florida 32801
September 2, 9, 2021 21-03093W

SECOND INSERTION

NOTICE OF FORECLOSURE SALE IN THE CIRCUIT COURT OF THE NINTH JUDICIAL CIRCUIT IN AND FOR ORANGE COUNTY, FLORIDA GENERAL JURISDICTION DIVISION

CASE NO. 2019-CA-010791-O
WELLS FARGO BANK, N.A., AS TRUSTEE FOR THE POOLING AND SERVICING AGREEMENT DATED AS OF OCTOBER 1, 2004 PARK PLACE SECURITIES, INC. ASSET-BACKED PASS-THROUGH CERTIFICATES SERIES 2004-MHQ1, Plaintiff, vs. TROY PECLET, ET AL. Defendant(s).

NOTICE IS HEREBY GIVEN pursuant to a Final Judgment of Foreclosure dated July 29, 2021, and entered in 2019-CA-010791-O of the Circuit Court of the NINTH Judicial Circuit in and for Orange County, Florida, wherein WELLS FARGO BANK, N.A., AS TRUSTEE FOR THE POOLING AND SERVICING AGREEMENT DATED AS OF OCTOBER 1, 2004 PARK PLACE SECURITIES, INC. ASSET-BACKED PASS-THROUGH CERTIFICATES SERIES 2004-MHQ1 is the Plaintiff and TROY PECLET; UNKNOWN SPOUSE OF TROY PECLET; UNITED STATES OF AMERICA, DEPARTMENT OF THE TREASURY-INTERNAL REVENUE SERVICE; ORANGE COUNTY, FLORIDA; STATE OF FLORIDA, DEPARTMENT OF REVENUE are the Defendant(s). Tiffany Moore Russell as the Clerk of the Circuit Court will sell to the highest and best bidder for cash at www.myorangeclerk.realforeclose.com, at 11:00 AM, on September 27, 2021, the following described property as set forth in said Final Judgment, to wit:

OF THE PUBLIC RECORDS OF ORANGE COUNTY, FLORIDA. Property Address: 4887 SEMINOLE AVE, WINTER PARK, FL 32792

Any person claiming an interest in the surplus from the sale, if any, other than the property owner as of the date of the lis pendens must file a claim in accordance with Florida Statutes, Section 45.031.

IMPORTANT AMERICANS WITH DISABILITIES ACT: If you are a person with a disability who needs any accommodation in order to participate in a court proceeding or event, you are entitled, at no cost to you, to the provision of certain assistance. Please contact Orange County, ADA Coordinator, Human Resources, Orange County Courthouse, 425 N. Orange Avenue, Suite 510, Orlando, Florida, (407) 836-2303, fax: 407-836-2204; and in Osceola County: ADA Coordinator, Court Administration, Osceola County Courthouse, 2 Court-house Square, Suite 6300, Kissimmee, FL 34741, (407) 742-2417, fax 407-835-5079, at least 7 days before your scheduled court appearance, or immediately upon receiving notification if the time before the scheduled court appearance is less than 7 days. If you are hearing or voice impaired, call 711 to reach the Telecommunications Relay Service. Dated this 25 day of August, 2021.

By: \S\Marni Sachs
Marni Sachs, Esquire
Florida Bar No. 92531
Communication Email: msachs@raslg.com
ROBERTSON, ANSCHUTZ, SCHNEID, CRANE & PARTNERS, PLLC
Attorney for Plaintiff
6409 Congress Ave., Suite 100
Boca Raton, FL 33487
Telephone: 561-241-6901
Facsimile: 561-997-6909
Service Email: flmail@raslg.com
19-366374 - MiM
September 2, 9, 2021 21-03006W

SECOND INSERTION

NOTICE OF SALE IN THE CIRCUIT COURT OF THE NINTH JUDICIAL CIRCUIT IN AND FOR ORANGE COUNTY, FLORIDA

CASE NO: 2016-CA-006341-O
HOLIDAY INN CLUB VACATIONS INCORPORATED, Plaintiff v. PAMELA ALEXANDRA JUDD, Defendant(s).

NOTICE IS GIVEN that, in accordance with the Consent Final Judgment of Foreclosure dated August 19, 2021, in the above-styled cause, the Clerk of Circuit Court Tiffany Moore Russell, shall sell the subject property at public sale on the 28th day of September, 2021, at 11 a.m., to the highest and best bidder for cash, at www.myorangeclerk.realforeclose.com for the following described property:

WEEK/UNIT(S): 7/003062
OF ORANGE LAKE COUNTRY CLUB VILLAS, A CONDOMINIUM. TOGETHER WITH AN UNDIVIDED INTEREST IN THE COMMON ELEMENTS APPURTENANT THERETO. ACCORDING TO THE DECLARATION OF CONDOMINIUM THEREOF RECORDED IN OFFICIAL RECORDS BOOK 3300, PAGE 2702, IN THE PUBLIC RECORDS OF ORANGE COUNTY, FLORIDA, AND ALL AMENDMENTS THERETO, THE PLAT OF WHICH IS RECORDED IN CONDOMINIUM BOOK 7, PAGE 59, UNTIL 12:00 NOON ON THE FIRST SATURDAY 2061, AT WHICH DATE SAID ESTATE SHALL TERMINATE; TOGETHER WITH A REMAINDER OVER IN FEE SIMPLE ABSOLUTE AS TENANT IN COMMON WITH THE OTHER OWNERS OF ALL THE UNIT WEEKS IN THE ABOVE DESCRIBED CONDOMINIUM IN THE PERCENTAGE INTEREST ESTABLISHED IN THE DECLARATION OF CONDOMINIUM.

NOTICE OF ACTION
Count VI
To: GERALD A. KELLY AND ANY AND ALL UNKNOWN HEIRS, DEVISEES AND OTHER CLAIMANTS OF GERALD A. KELLY AND JOHN C. WHITTEMORE, TRUSTEE OF THE JOHN C. AND ALICE M. WHITTEMORE LIVING TRUST DATED JULY 22, 2011 and ALICE M. WHITTEMORE, TRUSTEE OF THE JOHN C. AND ALICE M. WHITTEMORE LIVING TRUST DATED JULY 22, 2011

AND ALL PARTIES CLAIMING INTEREST BY, THROUGH, UNDER OR AGAINST DEFENDANT(S) GERALD A. KELLY AND ANY AND ALL UNKNOWN HEIRS, DEVISEES AND OTHER CLAIMANTS OF GERALD A. KELLY AND JOHN C. WHITTEMORE, TRUSTEE OF THE JOHN C. AND ALICE M. WHITTEMORE LIVING TRUST DATED JULY 22, 2011 AND ALICE M. WHITTEMORE, TRUSTEE OF THE JOHN C. AND ALICE M. WHITTEMORE LIVING TRUST DATED JULY 22, 2011 AND ALL PARTIES HAVING OR CLAIMING TO HAVE ANY RIGHT, TITLE OR INTEREST IN THE PROPERTY HEREIN DESCRIBED:

YOU ARE NOTIFIED that an action to foreclose a mortgage/claim of lien on the following described property in Orange County, Florida: WEEK/UNIT: 3 0DD/3635 of Orange Lake Country Club Villas III, a Condominium, together with an undivided interest in the common elements appurtenant thereto, according to the Declaration of Condominium thereof recorded in Official Records Book 5914, Page 1965, in the Public Records of Orange County, Florida, and all amendments thereto; the plat of which is recorded in Condominium Book 28, page 84-92 until 12:00 noon on the first Saturday 2071, at which date said estate shall terminate; TOGETHER with a remainder over in fee simple absolute as tenant in common with the other owners of all the unit weeks in the above described Condominium in the percentage interest established in the Declaration of Condominium.

has been filed against you and you are required to serve a copy of your written defenses, if any, to it on Jerry E. Aron, Plaintiff's attorney, whose address is 2505 Metrocentre Blvd., Suite 301, West Palm Beach, Florida, 33407, within thirty (30) days after the first publication of this Notice, and file the original with the Clerk of this Court either before service on Plaintiff's attorney or immediately thereafter, otherwise a default will be entered against you for the relief demanded in the Complaint.

If you are a person with disability who needs any accommodation in order to participate in a court proceeding or event, you are entitled, at no cost to you, to the provision of certain assistance. Please contact: in Orange County, ADA Coordinator, Human Resources, Orange County Courthouse, 425 N. Orange Avenue, Suite 510, Orlando, Florida, (407) 836-2303, fax: 407-836-2204; at least 7 days before your scheduled court appearance, or immediately upon receiving notification if the time before the scheduled court appearance is less than 7 days. If you are hearing or voice impaired, call 711 to reach the Telecommunications Relay Service.

IN THE CIRCUIT COURT, IN AND FOR ORANGE COUNTY, FLORIDA.

CASE NO.: 21-CA-006290-O #39
HOLIDAY INN CLUB VACATIONS INCORPORATED Plaintiff, vs. MARCELIN ET.AL., Defendant(s).

NOTICE OF ACTION
Count VI
To: GERALD A. KELLY AND ANY AND ALL UNKNOWN HEIRS, DEVISEES AND OTHER CLAIMANTS OF GERALD A. KELLY AND JOHN C. WHITTEMORE, TRUSTEE OF THE JOHN C. AND ALICE M. WHITTEMORE LIVING TRUST DATED JULY 22, 2011 and ALICE M. WHITTEMORE, TRUSTEE OF THE JOHN C. AND ALICE M. WHITTEMORE LIVING TRUST DATED JULY 22, 2011

And all parties claiming interest by, through, under or against Defendant(s) GERALD A. KELLY AND ANY AND ALL UNKNOWN HEIRS, DEVISEES AND OTHER CLAIMANTS OF GERALD A. KELLY AND JOHN C. WHITTEMORE, TRUSTEE OF THE JOHN C. AND ALICE M. WHITTEMORE LIVING TRUST DATED JULY 22, 2011 and ALICE M. WHITTEMORE, TRUSTEE OF THE JOHN C. AND ALICE M. WHITTEMORE LIVING TRUST DATED JULY 22, 2011 and all parties having or claiming to have any right, title or interest in the property herein described:

YOU ARE NOTIFIED that an action to foreclose a mortgage/claim of lien on the following described property in Orange County, Florida: WEEK/UNIT: 3 0DD/3635 of Orange Lake Country Club Villas III, a Condominium, together with an undivided interest in the common elements appurtenant thereto, according to the Declaration of Condominium thereof recorded in Official Records Book 5914, Page 1965, in the Public Records of Orange County, Florida, and all amendments thereto; the plat of which is recorded in Condominium Book 28, page 84-92 until 12:00 noon on the first Saturday 2071, at which date said estate shall terminate; TOGETHER with a remainder over in fee simple absolute as tenant in common with the other owners of all the unit weeks in the above described Condominium in the percentage interest established in the Declaration of Condominium.

has been filed against you and you are required to serve a copy of your written defenses, if any, to it on Jerry E. Aron, Plaintiff's attorney, whose address is 2505 Metrocentre Blvd., Suite 301, West Palm Beach, Florida, 33407, within thirty (30) days after the first publication of this Notice, and file the original with the Clerk of this Court either before service on Plaintiff's attorney or immediately thereafter, otherwise a default will be entered against you for the relief demanded in the Complaint.

If you are a person with disability who needs any accommodation in order to participate in a court proceeding or event, you are entitled, at no cost to you, to the provision of certain assistance. Please contact: in Orange County, ADA Coordinator, Human Resources, Orange County Courthouse, 425 N. Orange Avenue, Suite 510, Orlando, Florida, (407) 836-2303, fax: 407-836-2204; at least 7 days before your scheduled court appearance, or immediately upon receiving notification if the time before the scheduled court appearance is less than 7 days. If you are hearing or voice impaired, call 711 to reach the Telecommunications Relay Service.

TIFFANY MOORE RUSSELL
CLERK OF THE CIRCUIT COURT
ORANGE COUNTY, FLORIDA
8/19/2021
/s/ Nancy Garcia, 8/19/2021
Deputy Clerk
425 North Orange Ave.
Suite 350
Orlando, Florida 32801
September 2, 9, 2021 21-03183W

# ORANGE COUNTY

## SUBSEQUENT INSERTIONS

### SECOND INSERTION

NOTICE OF SALE PURSUANT TO CHAPTER 45 IN THE CIRCUIT COURT OF THE NINTH JUDICIAL CIRCUIT IN AND FOR ORANGE COUNTY, FLORIDA CIVIL ACTION CASE NO.: **48-2020-CA-002144-O**  
**LONGBRIDGE FINANCIAL LLC, Plaintiff, vs. DONALD E. GREEN, et al, Defendant(s).**  
 NOTICE IS HEREBY GIVEN Pursuant to a Final Judgment of Foreclosure dated July 26, 2021, and entered in Case No. 48-2020-CA-002144-O of the Circuit Court of the Ninth Judicial Circuit in and for Orange County, Florida in which Longbridge Financial LLC, is the Plaintiff and Donald E. Green, United States of America Acting through Secretary of Housing and Urban Development, Citibank, N.A., are defendants, the Orange County Clerk of the Circuit Court will sell to the highest and best bidder for cash in/on online at www.myorangeclerk.realforeclose.com, Orange County, Florida at 11:00am on the September 27, 2021 the following described property as set forth in said Final Judgment of Foreclosure:  
 LOT 14, BLOCK C, FERN COURT SUBDIVISION, ACCORDING TO THE PLAT THEREOF AS RECORDED IN PLAT BOOK R, PAGE 79 AND 80, PUBLIC RE-

CORDS OF ORANGE COUNTY, FLORIDA. A/K/A 2108 VALENCIA RD., ORLANDO FL 32803  
 Any person claiming an interest in the surplus from the sale, if any, other than the property owner as of the date of the Lis Pendens must file a claim before the Clerk reports the surplus as unclaimed. If you are a person with a disability who needs any accommodation in order to participate in this proceeding, you are entitled, at no cost to you, to the provision of certain assistance. Please contact the ADA Coordinator, Human Resources, Orange County Courthouse, 425 N. Orange Avenue, Suite 510, Orlando, Florida, (407) 836-2303, at least 7 days before your scheduled court appearance, or immediately upon receiving this notification if the time before the scheduled appearance is less than 7 days; if you are hearing or voice impaired, call 711.  
 Dated this 30 day of August, 2021.  
 By: /s/ Lynn Vouis  
 Florida Bar #870706  
 Lynn Vouis, Esq.  
 ALBERTELLI LAW  
 P. O. Box 23028  
 Tampa, FL 33623  
 Tel: (813) 221-4743  
 Fax: (813) 221-9171  
 eService: servealaw@albertellilaw.com  
 CT - 19-026476  
 September 2, 9, 2021 21-03242W

### SECOND INSERTION

NOTICE OF SALE IN THE CIRCUIT COURT OF THE 9TH JUDICIAL CIRCUIT IN AND FOR ORANGE COUNTY, FLORIDA CIVIL DIVISION CASE No. **2020-CA-003559-O** Div 34  
**MEB Loan Trust IV, U.S. Bank National Association, not in its individual capacity but solely as trustee Plaintiff, vs. LEO ESPOSITO and all unknown parties claiming by, through, under and against the above named Defendant who are unknown to be dead or alive whether said unknown are persons, heirs, devisees, grantees, or other claimants; UNKNOWN SPOUSE OF LEO ESPOSITO; SULMAN STEFANO; UNKNOWN SPOUSE OF SULMAN STEFANO; JOSELYN VERGARA; UNKNOWN SPOUSE OF JOSELYN VERGARA; TENANT I/UNKNOWN TENANT; TENANT II/UNKNOWN TENANT; TENANT III/UNKNOWN TENANT and TENANT IV/UNKNOWN TENANT, in possession of the subject real property, Defendants**  
 Notice is hereby given pursuant to the final judgment/order entered in the above noted case, that the Clerk of Court of Orange County, Florida will sell the following property situated in

Orange County, Florida described as: LOT(S) 9 AND 10, BLOCK C OF TIER 2 TOWN OF TAFT REPLAT AS RECORDED IN PLAT BOOK U, PAGE 53, OF THE PUBLIC RECORDS OF ORANGE COUNTY, FLORIDA.  
 at public sale, to the highest and best bidder for cash, at www.myorangeclerk.realforeclose.com , at 11:00 A.M. on October 5, 2021.  
 The highest bidder shall immediately post with the Clerk, a deposit equal to five percent (5%) of the final bid. The deposit must be cash or cashier's check payable to the Clerk of the Court. Final payment must be made on or before 4:00 P.M. on the date of the sale by cash or cashier's check.  
 Any person claiming an interest in the surplus from the sale, if any, other than the property owner as of the date of the lis pendens must file a claim before the clerk reports the surplus as unclaimed. The Court, in its discretion, may enlarge the time of the sale. Notice of the changed time of sale shall be published as provided herein.  
 DATED 26th August, 2021.  
 By WILLIAM NUSSBAUM III, ESQ.  
 Florida Bar No. 66479  
 LAW OFFICE OF GARY GASSELL, P.A., 2191 Ringling Boulevard Sarasota, Florida 34237 (941) 952-9322  
 Attorney for Plaintiff  
 September 2, 9, 2021 21-03003W

### SECOND INSERTION

NOTICE OF ACTION - CONSTRUCTIVE SERVICE - PROPERTY IN THE CIRCUIT COURT OF THE NINTH JUDICIAL CIRCUIT IN AND FOR ORANGE COUNTY, FLORIDA GENERAL JURISDICTION DIVISION CASE NO.: **2021-CA-008306-O**  
**BANK OF AMERICA, N.A., Plaintiff, vs. NEW AMERICA FINANCIAL, INC., d/b/a NEW AMERICA LTD., Defendant.**  
 TO: NEW AMERICA FINANCIAL, INC., d/b/a NEW AMERICA LTD.  
 YOU ARE NOTIFIED that an action to quiet title to a satisfied mortgage encumbering the following property in Orange County, Florida, to wit:  
 LOT 23, DEERFIELD PHASE 2-B, UNIT 4, ACCORDING TO THE PLAT THEREOF, AS RECORDED IN PLAT BOOK 26, PAGE 72 AND 73, PUBLIC RECORDS OF ORANGE COUNTY, FLORIDA.  
 has been filed against you and you are required to serve a copy of your written defenses, if any, to it on Robert A. Solove, Esq., Plaintiff's attorney, whose address is: SOLOVE LAW FIRM, P.A., PO Box 560608, Miami, Florida 33256, on or before thirty (30) days from first publication date , and file the original

with the Clerk of this Court either before service upon Plaintiff's attorney or immediately thereafter; otherwise, a default will be entered against you for the relief demanded in the Complaint.  
 In accordance with the Americans with Disabilities Act, persons needing a special accommodation to participate in this proceeding should contact the individual or agency sending this notice no later than seven (7) days prior to the proceeding at the address given on notice. Telephone 1(800) 955-8771; (TDD) 1(800) 955-8770 (V), via Florida Relay Services.  
 TIFFANY MOORE RUSSELL  
 Clerk of the Court  
 By: /s/ Stan Green  
 Deputy Clerk  
 Civil Division  
 425 N. Orange Avenue  
 Room 350  
 Orlando Florida 32801  
 Attorney for Plaintiff:  
 SOLOVE LAW FIRM, P.A.  
 c/o Robert A. Solove, Esq.  
 PO Box 560608  
 Miami, Florida 33256  
 Telephone: (305) 612-0800  
 Primary E-mail:  
 service@solovelawfirm.com  
 Secondary E-mail:  
 robert@solovelawfirm.com  
 September 2, 9, 16, 23, 2021  
 21-03008W

### SECOND INSERTION

IN THE CIRCUIT COURT, IN AND FOR ORANGE COUNTY, FLORIDA. CASE NO.: **21-CA-006287-O #33**  
**HOLIDAY INN CLUB VACATIONS INCORPORATED Plaintiff, vs. PAOLETTI ET.AL., Defendant(s).**  
 NOTICE OF ACTION Count III  
 To: VELDINE M. PEARSON  
 And all parties claiming interest by, through, under or against Defendant(s) VELDINE M. PEARSON and all parties having or claiming to have any right, title or interest in the property herein described:  
 YOU ARE NOTIFIED that an action to foreclose a mortgage/claim of lien on the following described property in Orange County, Florida:  
 WEEK/UNIT:  
 50 EVEN/86842  
 of Orange Lake Country Club Villas III, a Condominium, together with an undivided interest in the common elements appurtenant thereto, according to the Declaration of Condominium thereof recorded in Official Records Book 5914, Page 1965, in the Public Records of Orange County, Florida, and all amendments thereto; the plat of which is recorded in Condominium Book 28, page 84-92 until 12:00 noon on the first Saturday 2071, at which date said estate shall terminate; TOGETHER with a remainder over in fee simple absolute as tenant in common with the other owners of all the unit weeks in the above described

Condominium in the percentage interest established in the Declaration of Condominium.  
 has been filed against you and you are required to serve a copy of your written defenses, if any, to it on Jerry E. Aron, Plaintiff's attorney, whose address is 2505 Metrocentre Blvd., Suite 301, West Palm Beach, Florida, 33407, within thirty (30) days after the first publication of this Notice, and file the original with the Clerk of this Court either before service on Plaintiff's attorney or immediately thereafter, otherwise a default will be entered against you for the relief demanded in the Complaint.  
 If you are a person with disability who needs any accommodation in order to participate in a court proceeding or event, you are entitled, at no cost to you, to the provision of certain assistance. Please contact: in Orange County, ADA Coordinator, Human Resources, Orange County Courthouse, 425 N. Orange Avenue, Suite 510, Orlando, Florida, (407) 836-2303, fax: 407-836-2204; at least 7 days before your scheduled court appearance, or immediately upon receiving notification if the time before the scheduled court appearance is less than 7 days. If you are hearing or voice impaired, call 711 to reach the Telecommunications Relay Service.  
 TIFFANY MOORE RUSSELL  
 CLERK OF THE CIRCUIT COURT  
 ORANGE COUNTY, FLORIDA  
 August 19/2021  
 /s/ RAMONA VELEZ,  
 DEPUTY CLERK  
 425 North Orange Ave.  
 Suite 350  
 Orlando, Florida 32801  
 September 2, 9, 2021 21-03043W

### SECOND INSERTION

IN THE CIRCUIT COURT, IN AND FOR ORANGE COUNTY, FLORIDA. CASE NO.: **21-CA-005974-O #33**  
**HOLIDAY INN CLUB VACATIONS INCORPORATED Plaintiff, vs. ALVES NOIA ET.AL., Defendant(s).**  
 NOTICE OF ACTION Count VIII  
 To: GUSTAVO CARLOS CORDOVA MORILLO  
 And all parties claiming interest by, through, under or against Defendant(s) GUSTAVO CARLOS CORDOVA MORILLO and all parties having or claiming to have any right, title or interest in the property herein described:  
 YOU ARE NOTIFIED that an action to foreclose a mortgage/claim of lien on the following described property in Orange County, Florida:  
 WEEK/UNIT:  
 32/005114  
 of Orange Lake Country Club Villas I, a Condominium, together with an undivided interest in the common elements appurtenant thereto, according to the Declaration of Condominium thereof recorded in Official Records Book 3300, Page 2702, in the Public Records of Orange County, Florida, and all amendments thereto; the plat of which is recorded in Condominium Book 7, page 59 until 12:00 noon on the first Saturday 2061, at which date said estate shall terminate; TOGETHER with a remainder over in fee simple absolute as tenant in common with the other owners of all the unit

weeks in the above described Condominium in the percentage interest established in the Declaration of Condominium.  
 has been filed against you and you are required to serve a copy of your written defenses, if any, to it on Jerry E. Aron, Plaintiff's attorney, whose address is 2505 Metrocentre Blvd., Suite 301, West Palm Beach, Florida, 33407, within thirty (30) days after the first publication of this Notice, and file the original with the Clerk of this Court either before service on Plaintiff's attorney or immediately thereafter, otherwise a default will be entered against you for the relief demanded in the Complaint.  
 If you are a person with disability who needs any accommodation in order to participate in a court proceeding or event, you are entitled, at no cost to you, to the provision of certain assistance. Please contact: in Orange County, ADA Coordinator, Human Resources, Orange County Courthouse, 425 N. Orange Avenue, Suite 510, Orlando, Florida, (407) 836-2303, fax: 407-836-2204; at least 7 days before your scheduled court appearance, or immediately upon receiving notification if the time before the scheduled court appearance is less than 7 days. If you are hearing or voice impaired, call 711 to reach the Telecommunications Relay Service.  
 TIFFANY MOORE RUSSELL  
 CLERK OF THE CIRCUIT COURT  
 ORANGE COUNTY, FLORIDA  
 August 23rd, 2021  
 /s/ Liz Yanira Gordian Olmo  
 425 North Orange Ave.  
 Suite 350  
 Orlando, Florida 32801  
 September 2, 9, 2021 21-03023W

### SECOND INSERTION

IN THE CIRCUIT COURT, IN AND FOR ORANGE COUNTY, FLORIDA. CASE NO.: **21-CA-006288-O #34**  
**HOLIDAY INN CLUB VACATIONS INCORPORATED Plaintiff, vs. ARROYO ET.AL., Defendant(s).**  
 NOTICE OF ACTION Count I  
 To: JOSEPHINE ARROYO  
 And all parties claiming interest by, through, under or against Defendant(s) JOSEPHINE ARROYO and all parties having or claiming to have any right, title or interest in the property herein described:  
 YOU ARE NOTIFIED that an action to foreclose a mortgage/claim of lien on the following described property in Orange County, Florida:  
 WEEK/UNIT:  
 38 EVEN/86834  
 of Orange Lake Country Club Villas III, a Condominium, together with an undivided interest in the common elements appurtenant thereto, according to the Declaration of Condominium thereof recorded in Official Records Book 5914, Page 1965, in the Public Records of Orange County, Florida, and all amendments thereto; the plat of which is recorded in Condominium Book 28, page 84-92 until 12:00 noon on the first Saturday 2071, at which date said estate shall terminate; TOGETHER with a remainder over in fee simple absolute as tenant in common with the other owners of all the unit weeks in the above described

Condominium in the percentage interest established in the Declaration of Condominium.  
 has been filed against you and you are required to serve a copy of your written defenses, if any, to it on Jerry E. Aron, Plaintiff's attorney, whose address is 2505 Metrocentre Blvd., Suite 301, West Palm Beach, Florida, 33407, within thirty (30) days after the first publication of this Notice, and file the original with the Clerk of this Court either before service on Plaintiff's attorney or immediately thereafter, otherwise a default will be entered against you for the relief demanded in the Complaint. (10/14/2021)  
 If you are a person with disability who needs any accommodation in order to participate in a court proceeding or event, you are entitled, at no cost to you, to the provision of certain assistance. Please contact: in Orange County, ADA Coordinator, Human Resources, Orange County Courthouse, 425 N. Orange Avenue, Suite 510, Orlando, Florida, (407) 836-2303, fax: 407-836-2204; at least 7 days before your scheduled court appearance, or immediately upon receiving notification if the time before the scheduled court appearance is less than 7 days. If you are hearing or voice impaired, call 711 to reach the Telecommunications Relay Service.  
 TIFFANY MOORE RUSSELL  
 CLERK OF THE CIRCUIT COURT  
 ORANGE COUNTY, FLORIDA  
 8/19/2021  
 /s/ Nancy Garcia,  
 DEPUTY CLERK  
 425 North Orange Ave.  
 Suite 350  
 Orlando, Florida 32801  
 September 2, 9, 2021 21-03077W

### SECOND INSERTION

IN THE CIRCUIT COURT, IN AND FOR ORANGE COUNTY, FLORIDA. CASE NO.: **21-CA-005640-O #37**  
**HOLIDAY INN CLUB VACATIONS INCORPORATED Plaintiff, vs. GARCIA RIVAS ET.AL., Defendant(s).**  
 NOTICE OF ACTION Count IV  
 To: CHARLES WILLIAM HAYGOOD AND ANY AND ALL UNKNOWN HEIRS, DEVISEES AND OTHER CLAIMANTS OF CHARLES WILLIAM HAYGOOD  
 And all parties claiming interest by, through, under or against Defendant(s) CHARLES WILLIAM HAYGOOD AND ANY AND ALL UNKNOWN HEIRS, DEVISEES AND OTHER CLAIMANTS OF CHARLES WILLIAM HAYGOOD and all parties having or claiming to have any right, title or interest in the property herein described.  
 YOU ARE NOTIFIED that an action to foreclose a mortgage/claim of lien on the following described property:  
 STANDARD Interest(s) in the Orange Lake Land Trust ("Trust") evidenced for administrative, assessment and ownership purposes by 75000 points, which Trust was created pursuant to and further described in that certain Trust Agreement for Orange Lake Land Trust dated December 15, 2017, executed by and among Chicago Title Time-share Land Trust, Inc., a Florida Corporation, as the trustee of the Trust, Holiday Inn Club Vacations Incorporated, a Delaware corporation, f/k/a Orange Lake Country Club, Inc., a Delaware corporation, and Orange Lake Trust Owners' Association, Inc., a Florida not-for-profit corporation, as such agreement may be amended and supplemented from time to time ("Trust Agreement"), a memorandum

of which is recorded in Official Records Document Number: 20180061276, Public Records of Orange County, Florida ("Memorandum of Trust")All of the terms, restrictions, covenants, conditions and provisions contained in the Declaration and any amendments thereto, are incorporated herein by reference with the same effect as though fully set forth herein.  
 has been filed against you and you are required to serve a copy of your written defenses, if any, to it on Jerry E. Aron, Plaintiff's attorney, whose address is 2505 Metrocentre Blvd., Suite 301, West Palm Beach, Florida, 33407, within thirty (30) days after the first publication of this Notice, and file the original with the Clerk of this Court either before service on Plaintiff's attorney or immediately thereafter, otherwise a default will be entered against you for the relief demanded in the Complaint.  
 If you are a person with disability who needs any accommodation in order to participate in a court proceeding or event, you are entitled, at no cost to you, to the provision of certain assistance. Please contact: in Orange County, ADA Coordinator, Human Resources, Orange County Courthouse, 425 N. Orange Avenue, Suite 510, Orlando, Florida, (407) 836-2303, fax: 407-836-2204; at least 7 days before your scheduled court appearance, or immediately upon receiving notification if the time before the scheduled court appearance is less than 7 days. If you are hearing or voice impaired, call 711 to reach the Telecommunications Relay Service.  
 TIFFANY MOORE RUSSELL  
 CLERK OF THE CIRCUIT COURT  
 ORANGE COUNTY, FLORIDA  
 August 23rd, 2021  
 /s/ Liz Yanira Gordian Olmo  
 DEPUTY CLERK  
 425 North Orange Ave.  
 Suite 350  
 Orlando, Florida 32801  
 September 2, 9, 2021 21-03160W

### SECOND INSERTION

IN THE CIRCUIT COURT, IN AND FOR ORANGE COUNTY, FLORIDA. CASE NO.: **21-CA-005649-O #36**  
**HOLIDAY INN CLUB VACATIONS INCORPORATED Plaintiff, vs. STANFIELD ET.AL., Defendant(s).**  
 NOTICE OF ACTION Count IX  
 To: LIREY ENID VISUETTI TORRES and WILFREDO ESCOTT GALANO and OSVALDO ANEL VISUETTI SAMANIEGO and DILMA ESTHER TORRES GOMEZ DE VISUETTI  
 And all parties claiming interest by, through, under or against Defendant(s) LIREY ENID VISUETTI TORRES and WILFREDO ESCOTT GALANO and OSVALDO ANEL VISUETTI SAMANIEGO and DILMA ESTHER TORRES GOMEZ DE VISUETTI and all parties having or claiming to have any right, title or interest in the property herein described.  
 YOU ARE NOTIFIED that an action to foreclose a mortgage/claim of lien on the following described property:  
 STANDARD Interest(s) in the Orange Lake Land Trust ("Trust") evidenced for administrative, assessment and ownership purposes by 75000 points, which Trust was created pursuant to and further described in that certain Trust Agreement for Orange Lake Land Trust dated December 15, 2017, executed by and among Chicago Title Time-share Land Trust, Inc., a Florida Corporation, as the trustee of the Trust, Holiday Inn Club Vacations Incorporated, a Delaware corporation, f/k/a Orange Lake Country Club, Inc., a Delaware corporation, and Orange Lake Trust Owners' Association, Inc., a Florida not-for-profit corporation, as such agreement may be amended and supplemented from time to time ("Trust Agreement"), a memorandum

of which is recorded in Official Records Document Number: 20180061276, Public Records of Orange County, Florida ("Memorandum of Trust")All of the terms, restrictions, covenants, conditions and provisions contained in the Declaration and any amendments thereto, are incorporated herein by reference with the same effect as though fully set forth herein.  
 has been filed against you and you are required to serve a copy of your written defenses, if any, to it on Jerry E. Aron, Plaintiff's attorney, whose address is 2505 Metrocentre Blvd., Suite 301, West Palm Beach, Florida, 33407, within thirty (30) days after the first publication of this Notice, and file the original with the Clerk of this Court either before service on Plaintiff's attorney or immediately thereafter, otherwise a default will be entered against you for the relief demanded in the Complaint.  
 If you are a person with disability who needs any accommodation in order to participate in a court proceeding or event, you are entitled, at no cost to you, to the provision of certain assistance. Please contact: in Orange County, ADA Coordinator, Human Resources, Orange County Courthouse, 425 N. Orange Avenue, Suite 510, Orlando, Florida, (407) 836-2303, fax: 407-836-2204; at least 7 days before your scheduled court appearance, or immediately upon receiving notification if the time before the scheduled court appearance is less than 7 days. If you are hearing or voice impaired, call 711 to reach the Telecommunications Relay Service.  
 TIFFANY MOORE RUSSELL  
 CLERK OF THE CIRCUIT COURT  
 ORANGE COUNTY, FLORIDA  
 8/19/2021  
 /s/ Lisa Geib  
 DEPUTY CLERK  
 425 North Orange Ave.  
 Suite 350  
 Orlando, Florida 32801  
 September 2, 9, 2021 21-03156W

### SECOND INSERTION

IN THE CIRCUIT COURT, IN AND FOR ORANGE COUNTY, FLORIDA. CASE NO.: **21-CA-005589-O #34**  
**HOLIDAY INN CLUB VACATIONS INCORPORATED Plaintiff, vs. ARANEDA CRUZ ET.AL., Defendant(s).**  
 NOTICE OF ACTION Count VI  
 To: REYNALDO ESPINOSA, JR. AND ANY AND ALL UNKNOWN HEIRS, DEVISEES AND OTHER CLAIMANTS OF REYNALDO ESPINOSA, JR.  
 And all parties claiming interest by, through, under or against Defendant(s) REYNALDO ESPINOSA, JR. AND ANY AND ALL UNKNOWN HEIRS, DEVISEES AND OTHER CLAIMANTS OF REYNALDO ESPINOSA, JR. and all parties having or claiming to have any right, title or interest in the property herein described.  
 YOU ARE NOTIFIED that an action to foreclose a mortgage/claim of lien on the following described property:  
 STANDARD Interest(s) in the Orange Lake Land Trust ("Trust") evidenced for administrative, assessment and ownership purposes by 90000 points, which Trust was created pursuant to and further described in that certain Trust Agreement for Orange Lake Land Trust dated December 15, 2017, executed by and among Chicago Title Time-share Land Trust, Inc., a Florida Corporation, as the trustee of the Trust, Holiday Inn Club Vacations Incorporated, a Delaware corporation, f/k/a Orange Lake Country Club, Inc., a Delaware corporation, and Orange Lake Trust Owners' Association, Inc., a Florida not-for-profit corporation, as such agreement may be amended and supplemented from time to time ("Trust Agreement"), a memorandum of which is recorded in Official

Records Document Number: 20180061276, Public Records of Orange County, Florida ("Memorandum of Trust")All of the terms, restrictions, covenants, conditions and provisions contained in the Declaration and any amendments thereto, are incorporated herein by reference with the same effect as though fully set forth herein.  
 has been filed against you and you are required to serve a copy of your written defenses, if any, to it on Jerry E. Aron, Plaintiff's attorney, whose address is 2505 Metrocentre Blvd., Suite 301, West Palm Beach, Florida, 33407, within thirty (30) days after the first publication of this Notice, and file the original with the Clerk of this Court either before service on Plaintiff's attorney or immediately thereafter, otherwise a default will be entered against you for the relief demanded in the Complaint. (10/14/2021)  
 If you are a person with disability who needs any accommodation in order to participate in a court proceeding or event, you are entitled, at no cost to you, to the provision of certain assistance. Please contact: in Orange County, ADA Coordinator, Human Resources, Orange County Courthouse, 425 N. Orange Avenue, Suite 510, Orlando, Florida, (407) 836-2303, fax: 407-836-2204; at least 7 days before your scheduled court appearance, or immediately upon receiving notification if the time before the scheduled court appearance is less than 7 days. If you are hearing or voice impaired, call 711 to reach the Telecommunications Relay Service.  
 TIFFANY MOORE RUSSELL  
 CLERK OF THE CIRCUIT COURT  
 ORANGE COUNTY, FLORIDA  
 8/19/2021  
 /s/ Nancy Garcia  
 DEPUTY CLERK  
 425 North Orange Ave.  
 Suite 350  
 Orlando, Florida 32801  
 September 2, 9, 2021 21-03072W



**ORANGE COUNTY  
SUBSEQUENT INSERTIONS**

**SECOND INSERTION**

NOTICE OF FORECLOSURE SALE IN THE CIRCUIT COURT OF THE NINTH JUDICIAL CIRCUIT IN AND FOR ORANGE COUNTY, FLORIDA GENERAL JURISDICTION DIVISION  
**CASE NO. 2016-CA-011267-O**  
**U.S. BANK NATIONAL ASSOCIATION, AS TRUSTEE FOR RESIDENTIAL FUNDING MORTGAGE SECURITIES I, INC., MORTGAGE PASS-THROUGH CERTIFICATES, SERIES 2007-SA2, Plaintiff, vs. LYDIA H CRAYTON A/K/A LYDIA CRAYTON AND ANDRAE CRAYTON, ET AL. Defendant(s).**  
NOTICE IS HEREBY GIVEN pursuant to a Final Judgment of Foreclosure dated May 31, 2019, and entered in 2016-CA-011267-O of the Circuit Court of the NINTH Judicial Circuit in and for Orange County, Florida, wherein U.S. BANK NATIONAL ASSOCIATION, AS TRUSTEE FOR RESIDENTIAL FUNDING MORTGAGE SECURITIES I, INC., MORTGAGE PASS-THROUGH CERTIFICATES, SERIES 2007-SA2 is the Plaintiff and LYDIA H CRAYTON A/K/A LYDIA CRAYTON; ANDRAE CRAYTON; WINDERMERE CHASE HOMEOWNERS ASSO-

CIATION, INC.; AQUA FINANCE, INC.; STATE OF FLORIDA, DEPARTMENT OF REVENUE are the Defendant(s). Tiffany Moore Russell as the Clerk of the Circuit Court will sell to the highest and best bidder for cash at www.myorangeclerk.com, at 11:00 AM, on September 22, 2021, the following described property as set forth in said Final Judgment, to wit:  
LOT 37, WINDERMERE CHASE PHASE 2, ACCORDING TO THE PLAT THEREOF AS RECORDED IN PLAT BOOK 42, PAGE 106 THROUGH 108, OF THE PUBLIC RECORDS OF ORANGE COUNTY, FLORIDA.  
Property Address: 706 GENTRY COURT, GOTHA, FL 34734  
Any person claiming an interest in the surplus from the sale, if any, other than the property owner as of the date of the lis pendens must file a claim in accordance with Florida Statutes, Section 45.031.

**IMPORTANT AMERICANS WITH DISABILITIES ACT.** If you are a person with a disability who needs any accommodation in order to participate in a court proceeding or event, you are entitled, at no cost to you, to the provision of certain assis-

tance. Please contact Orange County, ADA Coordinator, Human Resources, Orange County Courthouse, 425 N. Orange Avenue, Suite 510, Orlando, Florida, (407) 836-2303, fax: 407-836-2204; and in Osceola County: ADA Coordinator, Court Administration, Osceola County Courthouse, 2 Courthouse Square, Suite 6300, Kissimmee, FL 34741, (407) 742-2417, fax 407-835-5079, at least 7 days before your scheduled court appearance, or immediately upon receiving notification if the time before the scheduled court appearance is less than 7 days. If you are hearing or voice impaired, call 711 to reach the Telecommunications Relay Service.  
Dated this 25 day of August, 2021.  
By: (S/Nicole Ramjattan Nicole Ramjattan, Esquire Florida Bar No. 89204 Communication Email: nramjattan@raslg.com  
**ROBERTSON, ANSCHUTZ, SCHNEID, CRANE & PARTNERS, PLLC Attorney for Plaintiff** 6409 Congress Ave., Suite 100 Boca Raton, FL 33487 Telephone: 561-241-6901 Facsimile: 561-997-6909 Service Email: flmail@raslg.com 16-216742 - SaL September 2, 9, 2021 21-03007W

**SECOND INSERTION**

IN THE CIRCUIT COURT, IN AND FOR ORANGE COUNTY, FLORIDA.  
**CASE NO.: 21-CA-005589-O #34 HOLIDAY INN CLUB VACATIONS INCORPORATED Plaintiff, vs. ARANEDA CRUZ ET.AL., Defendant(s).**  
NOTICE OF ACTION  
Count V  
To: LARRY DARWIN CRAGLE AND ANY AND ALL UNKNOWN HEIRS, DEVISEES AND OTHER CLAIMANTS OF LARRY DARWIN CRAGLE and SHERRY BELZONS AND ANY AND ALL UNKNOWN HEIRS, DEVISEES AND OTHER CLAIMANTS OF SHERRY BELZONS And all parties claiming interest by, through, under or against Defendant(s) LARRY DARWIN CRAGLE AND ANY AND ALL UNKNOWN HEIRS, DEVISEES AND OTHER CLAIMANTS OF SHERRY BELZONS And all parties having or claiming to have any right, title or interest in the property herein described.  
YOU ARE NOTIFIED that an action to foreclose a mortgage/claim of lien on the following described property :  
SIGNATURE Interest(s) in the Orange Lake Land Trust ("Trust") evidenced for administrative, assessment and owner-

ship purposes by 75000 points, which Trust was created pursuant to and further described in that certain Trust Agreement for Orange Lake Land Trust dated December 15, 2017, executed by and among Chicago Title Timeshare Land Trust, Inc., a Florida Corporation, as the trustee of the Trust, Holiday Inn Club Vacations Incorporated, a Delaware corporation, f/k/a Orange Lake Country Club, Inc., a Delaware corporation, and Orange Lake Trust Owners' Association, Inc., a Florida not-for-profit corporation, as such agreement may be amended and supplemented from time to time ("Trust Agreement"), a memorandum of which is recorded in Official Records Document Number: 20180061276, Public Records of Orange County, Florida ("Memorandum of Trust") All of the terms, restrictions, covenants, conditions and provisions contained in the Declaration and any amendments thereto, are incorporated herein by reference with the same effect as though fully set forth herein.  
has been filed against you and you are required to serve a copy of your written defenses, if any, to it on Jerry E. Aron, Plaintiff's attorney, whose address is 2505 Metrocentre Blvd.,

Suite 301, West Palm Beach, Florida, 33407, within thirty (30) days after the first publication of this Notice, and file the original with the Clerk of this Court either before service on Plaintiff's attorney or immediately thereafter, otherwise a default will be entered against you for the relief demanded in the Complaint.  
If you are a person with disability who needs any accommodation in order to participate in a court proceeding or event, you are entitled, at no cost to you, to the provision of certain assistance. Please contact: in Orange County, ADA Coordinator, Human Resources, Orange County Courthouse, 425 N. Orange Avenue, Suite 510, Orlando, Florida, (407) 836-2303, fax: 407-836-2204; at least 7 days before your scheduled court appearance, or immediately upon receiving notification if the time before the scheduled court appearance is less than 7 days. If you are hearing or voice impaired, call 711 to reach the Telecommunications Relay Service.  
TIFFANY MOORE RUSSELL CLERK OF THE CIRCUIT COURT ORANGE COUNTY, FLORIDA (10/14/2021) /s/ Nancy Garcia DEPUTY CLERK 425 North Orange Ave. Suite 350 Orlando, Florida 32801 September 2, 9, 2021 21-03071W

**SECOND INSERTION**

**NOTICE TO CREDITORS IN THE CIRCUIT COURT FOR ORANGE COUNTY, FLORIDA PROBATE DIVISION File No. 2021-CP-002671-O IN RE: ESTATE OF SARA BETH O'CONNOR Deceased.**  
The administration of the estate of SARA BETH O'CONNOR, deceased, whose date of death was July 19, 2021, is pending in the Circuit Court for Orange County, Florida, Probate Division, the address of which is 425 N. Orange Ave., Suite 355, Orlando, FL 32801. The names and addresses of the personal representative and the personal representative's attorney are set forth below.  
All creditors of the decedent and other persons having claims or demands against decedent's estate, on whom a copy of this notice is required to be served, must file their claims with this court ON OR BEFORE THE LATER OF 3 MONTHS AFTER THE TIME OF THE FIRST PUBLICATION OF THIS NOTICE OR 30 DAYS AFTER THE DATE OF SERVICE OF A COPY OF THIS NOTICE ON THEM.  
All other creditors of the decedent and other persons having claims or demands against decedent's estate must file their claims with this court WITHIN 3 MONTHS AFTER THE DATE OF THE FIRST PUBLICATION OF THIS NOTICE.  
ALL CLAIMS NOT FILED WITHIN THE TIME PERIODS SET FORTH IN FLORIDA STATUTES SECTION 733.702 WILL BE FOREVER BARRED.  
NOTWITHSTANDING THE TIME PERIOD SET FORTH ABOVE, ANY CLAIM FILED TWO (2) YEARS OR MORE AFTER THE DECEDENT'S DATE OF DEATH IS BARRED.  
The date of first publication of this notice is September 2, 2021  
/s/ Glenn Treanor Personal Representative 1406 Kimberly St Ocoee, FL 34761  
/s/ Donald Gervase Attorney for Personal Representative Florida Bar No. 95584 Provision Law PLLC 310 S. Dillard St. Ste 140 Winter Garden, FL 34787 Telephone: 407-287-6767 Email: dgervase@provisionlaw.com September 2, 9, 2021 21-03234W

**NOTICE TO CREDITORS IN THE CIRCUIT COURT FOR ORANGE COUNTY, FLORIDA PROBATE DIVISION File No.: 2021-CP-002661-O Division: 01 IN RE: ESTATE OF JOHN J. HRABOSKY, JR. Deceased.**  
The administration of the estate of John J. Hrabosky, Jr. deceased, whose date of death was November 24, 2020, is pending in the Circuit Court for Orange County, Florida, Probate Division, the address of which is 425 N. Orange Avenue, Suite #355, Orlando, Florida 32801. The name and address of the personal representative and the personal representative's attorney are set forth below.  
All creditors of the decedent and other persons having claims or demands against the estate of the decedent on whom a copy of this notice is required to be served must file their claims with this court ON OR BEFORE THE LATER OF 3 MONTHS AFTER THE TIME OF THE FIRST PUBLICATION OF THIS NOTICE OR 30 DAYS AFTER THE DATE OF SERVICE OF A COPY OF THIS NOTICE ON THEM.  
All other creditors of the decedent and other persons having claims or demands against the estate of the decedent must file their claims with this court WITHIN 3 MONTHS AFTER THE DATE OF THE FIRST PUBLICATION OF THIS NOTICE.  
ALL CLAIMS NOT FILED WITHIN THE TIME PERIODS SET FORTH IN SECTION 733.702 WILL BE FOREVER BARRED.  
NOTWITHSTANDING THE TIME PERIODS SET FORTH ABOVE, ANY CLAIM FILED TWO (2) YEARS OR MORE AFTER THE DECEDENT'S DATE OF DEATH IS BARRED.  
The date of first publication of this Notice is September 2, 2021.  
**Personal Representative: Charlene M. Hrabosky** 1 Nashville Court Tinton Falls, NJ 07712 Attorney for Personal Representative: Jose M. Cañas, Esquire Florida Bar Number: 25402 9780 E. Indigo Street, Suite 101 Palmetto Bay, Florida 33157 Telephone: (305) 666-9697 Facsimile: (786) 209-0590 E-Mail: canaslaw@bellsouth.net September 2, 9, 2021 21-03204W

**SECOND INSERTION**

**NOTICE TO CREDITORS IN THE CIRCUIT COURT FOR ORANGE COUNTY, FLORIDA PROBATE DIVISION File No.: 2021-CP-002095-O Division: 1 IN RE: ESTATE OF ROBERT NEWTON BLOOMFIELD Deceased.**  
The administration of the estate of Robert Newton Bloomfield, deceased, whose date of death was February 24, 2021, is pending in the Circuit Court for Orange County, Florida, Probate Division, the address of which is 425 N. Orange Avenue, Orlando, Florida 32801. The names and addresses of the personal representative and the personal representative's attorney are set forth below.  
All creditors of the decedent and other persons having claims or demands against decedent's estate on whom a copy of this notice is required to be served must file their claims with this court ON OR BEFORE THE LATER OF 3 MONTHS AFTER THE TIME OF THE FIRST PUBLICATION OF THIS NOTICE OR 30 DAYS AFTER THE DATE OF SERVICE OF A COPY OF THIS NOTICE ON THEM.  
All other creditors of the decedent and other persons having claims or demands against decedent's estate must file their claims with this court WITHIN 3 MONTHS AFTER THE DATE OF THE FIRST PUBLICATION OF THIS NOTICE.  
ALL CLAIMS NOT FILED WITHIN THE TIME PERIODS SET FORTH IN FLORIDA STATUTES SECTION 733.702 WILL BE FOREVER BARRED.  
NOTWITHSTANDING THE TIME PERIODS SET FORTH ABOVE, ANY CLAIM FILED TWO (2) YEARS OR MORE AFTER THE DECEDENT'S DATE OF DEATH IS BARRED.  
The date of first publication of this Notice is September 2, 2021.  
**Personal Representative: Taj Bloomfield** 8252 SW 25th Court Miramar, FL 33025 Attorney for Personal Representative: Aliana M. Payret Email Address: apayret@lawdrive.com Florida Bar No. 104377 Robinson, Pecaro & Mier, P.A. 201 N. Kentucky Avenue, #2 Lakeland, FL 33801 September 2, 9, 2021 21-03205W

**SECOND INSERTION**

**NOTICE OF ACTION IN THE CIRCUIT COURT OF THE NINTH JUDICIAL CIRCUIT IN AND FOR ORANGE COUNTY, FLORIDA CIRCUIT CIVIL DIVISION CASE NO.: 2021-CA-006225-O U.S. BANK TRUST NATIONAL ASSOCIATION, AS TRUSTEE OF THE IGLOO SERIES II TRUST, Plaintiff, v. THE UNKNOWN HEIRS, SPOUSES, BENEFICIARIES, DEVISEES, GRANTEES, ASSIGNEES, LIENORS, CREDITORS, TRUSTEES AND ALL OTHERS WHO MAY CLAIM AN INTEREST IN THE ESTATE OF SHIRLEY RIVERS A/K/A SHIRLEY A. RIVERS, (DECEASED), et al., Defendants.**  
TO: THE UNKNOWN HEIRS, SPOUSES, BENEFICIARIES, DEVISEES, GRANTEES, ASSIGNEES, LIENORS, CREDITORS, TRUSTEES AND ALL OTHERS WHO MAY CLAIM AN INTEREST IN THE ESTATE OF SHIRLEY RIVERS A/K/A SHIRLEY A. RIVERS, DECEASED Last Known Address: UNKNOWN  
YOU ARE HEREBY NOTIFIED that an action to foreclose a mortgage on the following property located in Miami Dade County, Florida:

BEGIN AT A POINT ON THE WEST SIDE OF THE RAILROAD RIGHT-OF-WAY, 16 RODS NORTH OF THE SOUTH LINE OF THE NORTHEAST 1/4 OF THE SOUTHEAST 1/4 OF SECTION 6, TOWNSHIP 23 SOUTH, RANGE 28 EAST, ORANGE COUNTY, FLORIDA; RUN THENCE WEST PARALLEL TO THE SAID SOUTH LINE OF THE NORTHEAST 1/4, 20 RODS TO THE POINT OF BEGINNING; RUN THENCE SOUTHWESTERLY PARALLEL WITH THE RAILROAD RIGHT-OF-WAY TO THE NORTH SIDE OF WINTER GARDEN ROAD; THENCE WESTERLY ALONG THE NORTH SIDE OF SAID ROAD, A DISTANCE OF 100 FEET; THENCE NORTHEASTERLY PARALLEL WITH THE RAILROAD RIGHT OF-WAY TO A POINT DUE WEST OF THE POINT OF BEGINNING; THENCE EASTERLY PARALLEL WITH THE NORTH SIDE OF WINTER GARDEN ROAD, A DISTANCE OF 100 FEET TO THE POINT OF BEGINNING. INCLUDING THE BUILD-

INGS, APPURTENANCES, AND FIXTURES LOCATED THEREON.  
PROPERTY ADDRESS: 11315 WINDERMERE ROAD, WINDERMERE, FL 34786  
filed against you and you are required to serve a copy of your written defenses, if any, to it on HARRIS S. HOWARD, ESQ., of HOWARD LAW GROUP, Plaintiff's attorney, whose address is 4755 Technology Way, Suite 104 Boca Raton, FL 33431 on or before 30 days from the first date of publication 2021 (no later than 30 days from the date of the first publication of this Notice of Action) and file the original with the Clerk of this Court either before service on Plaintiff's attorney or immediately thereafter; otherwise a default will be entered against you for the relief demanded in the Complaint or petition filed herein.  
WITNESS my hand and seal of this Court at Broward, Florida on this 31 day of August, 2021.  
CLERK OF COURT Tiffany Moore Russell By yamina azizi, Deputy Clerk Civil Division 425 N. Orange Avenue Room 350 Orlando, Florida 32801 September 2, 9, 2021 21-03240W

**SECOND INSERTION**

**NOTICE OF ACTION IN THE CIRCUIT COURT OF THE 9TH JUDICIAL CIRCUIT, IN AND FOR ORANGE COUNTY, FLORIDA CIVIL DIVISION CASE NO. 2021-CA-002408-O WELLS FARGO BANK, NATIONAL ASSOCIATION, AS TRUSTEE FOR THE HOLDERS OF THE FIRST FRANKLIN MORTGAGE LOAN TRUST 2006-FF17 MORTGAGE PASS-THROUGH CERTIFICATES, SERIES 2006-FF17, Plaintiff, vs. VIVEK KALRA; UNKNOWN SPOUSE OF VIVEK KALRA; SANDRA K. JACKSON A/K/A SANDRA JACKSON; JOHN H. WILEY A/K/A JOHN WILEY; VISTA LAKES COMMUNITY ASSOCIATION, INC.; UNKNOWN PERSON(S) IN POSSESSION OF THE SUBJECT PROPERTY, Defendant(s)**  
To the following Defendant(s): UNKNOWN PERSON(S) IN POSSESSION OF THE SUBJECT PROPERTY 8758 HASTINGS BEACH BLVD ORLANDO, FLORIDA 32829 who is evading service of process and the unknown defendants who may be spouses, heirs, devisees, grantees, assignees, lienors, creditors, trustees, and all parties claiming an interest by, through, under or against the defendant(s), who are not known to be dead

or alive, and all parties having or claiming to have any right, title or interest in the property described in the mortgage being foreclosed herein.  
YOU ARE NOTIFIED that an action for Foreclosure of Mortgage on the following described property:  
LOT 181, VISTA LAKES VILLAGES N-8 AND N-9 (NEWPORT), AS PER PLAT THEREOF, RECORDED IN PLAT BOOK 53, PAGE 71 - 81, OF THE PUBLIC RECORDS OF ORANGE COUNTY, FLORIDA. A/K/A 8758 HASTINGS BEACH BLVD, ORLANDO, FLORIDA 32829  
has been filed against you and you are required to serve a copy of your written defenses, if any, to it, on Kahane & Associates, P.A., Attorney for Plaintiff, whose address is 8201 Peters Road, Suite 3000, Plantation, FLORIDA 33324 on or before 30 days from the first date of publication, a date which is within thirty (30) days after the first publication of this Notice in the BUSINESS OBSERVER and file the original with the Clerk of this Court either before service on Plaintiff's attorney or immediately thereafter; otherwise a default will be entered against you for the relief demanded in the complaint.  
This notice is provided pursuant to Administrative Order No. 2.065. In accordance with the American with Disabilities Act, if you are a person

with a disability who needs any accommodation in order to participate in this proceeding, you are entitled, at no cost to you, to the provision of certain assistance. Please contact the ADA Coordinator, Human Resources, Orange County Courthouse, 425 N. Orange Avenue, Suite 510, Orlando, Florida, (407) 836-2303, at least 7 days before your scheduled Court Appearance, or immediately upon receiving this notification if the time before the scheduled appearance is less than 7 days; if you are hearing or voice impaired, call 711.  
WITNESS my hand and the seal of this Court this 25th day of August, 2021.  
TIFFANY MOORE RUSSELL As Clerk of the Court By: /s/ Liz Yanira Gordian Olmo, As Deputy Clerk Civil Court Seal Civil Division 425 N. Orange Avenue Room 350 Orlando, Florida 32801  
Submitted by: Kahane & Associates, P.A. 8201 Peters Road, Ste. 3000 Plantation, FL 33324 Telephone: (954) 382-3486 Telefacsimile: (954) 382-5380 Designated service email: notice@kahaneandassociates.com File No.: 20-00840 SPS September 2, 9, 2021 21-03004W

**THIRD INSERTION**

**NOTICE OF ACTION IN THE COUNTY COURT OF THE NINTH JUDICIAL CIRCUIT IN AND FOR ORANGE COUNTY, FLORIDA CASE NO.: 2021-CC-005921-O PALM COVE HOMES, LLC d/b/a Riverside Mobile Home Community, Plaintiff, vs. PETER SOLTZ & DARRELL E. PUTNEY, Defendants.**  
TO: Peter Soltz 1569 Genie Street Orlando, Florida 32828  
YOU ARE NOTIFIED that an action to imposition and foreclosure of a statutory landlord's lien as to the mobile home described as:  
1974 JAMI mobile home bearing vehicle identification number 2959  
has been filed against you, and you are required to serve a copy of your written defenses, if any, to it on Brian C. Chase, Esq., Plaintiff's attorney, whose

address is 3902 N. Marguerite Street, Tampa, Florida 33603, ON OR BEFORE A DATE WHICH IS WITHIN 30 DAYS OF FIRST PUBLICATION OF THIS NOTICE IN THE BUSINESS OBSERVER, and file the original with the Clerk of this Court either before service on Plaintiff's attorney or immediately thereafter; otherwise a default will be entered against you for the relief demanded in the Complaint or petition.  
WITNESS Tiffany Moore Russell, as Clerk of the County Court, and the seal of said Court, at the Courthouse at Orange County, Florida.  
Dated: 07/11/2021  
Tiffany Moore Russell Orange County Clerk of Court By: /s/ Stan Green Deputy Clerk Civil Division 425 N. Orange Avenue Room 350 Orlando, Florida 32801 August 26; September 2, 9, 16, 2021 21-02883W

**SECOND INSERTION**

Notice of Self Storage Sale  
Please take notice US Storage Centers - Winter Park located at 7000 Aloma Avenue Winter Park, FL 32792 intends to hold a sale to sell the property stored at the Facility by the below list Occupants whom are in default at an Auction. The sale will occur as an on-line auction via www.storageetreasures.com on 9/21/2021 at 10:00am. Unless stated otherwise the description of the contents are household goods and furnishings. Allen Collins unit #C833; Al F Maxey unit #D741; Marci Zayon units #D742 & #E300; Linden Samuels unit #E289. This sale may be withdrawn at any time without notice. Certain terms and conditions apply. See manager for details.  
September 2, 9, 2021 21-03017W

**OFFICIAL COURTHOUSE WEBSITES:**  
**MANATEE COUNTY:** manateclerk.com | **SARASOTA COUNTY:** sarasotaclerk.com  
**CHARLOTTE COUNTY:** charlotte.realforeclose.com | **LEE COUNTY:** leeclerk.org  
**COLLIER COUNTY:** collierclerk.com | **HILLSBOROUGH COUNTY:** hillsclerk.com  
**PASCO COUNTY:** pasco.realforeclose.com | **PINELLAS COUNTY:** pinellasclerk.org  
**POLK COUNTY:** polkcountyclerk.net | **ORANGE COUNTY:** myorangeclerk.com

Check out your notices on:  
**www.floridapublicnotices.com**

**Business Observer**

**ORANGE COUNTY**  
**SUBSEQUENT INSERTIONS**

**SECOND INSERTION**

**NOTICE OF ACTION FORECLOSURE**  
PROCEEDINGS - PROPERTY IN THE CIRCUIT COURT OF THE NINTH JUDICIAL CIRCUIT IN AND FOR ORANGE COUNTY, FLORIDA  
**CASE NO: 2021-CA-004180-O WILMINGTON SAVINGS FUND SOCIETY, FSB, NOT IN ITS INDIVIDUAL CAPACITY BUT SOLELY AS OWNER TRUSTEE OF CSMC 2017-RPL2 TRUST, Plaintiff, v. NELSON ROMAN; ET AL., Defendant(s)**  
TO: NELSON ROMAN  
Residence unknown, if living, including any unknown spouse of the said Defendants, if either has remarried and if either or both of said Defendants are dead, their respective unknown heirs, devisees, grantee, assignees, creditors, lienors, and trustees, and all other persons claiming by, through, under or against the named Defendant(s); and the aforementioned named Defendant(s) and such of the aforementioned unknown Defendants and such of the aforementioned unknown Defendants as may be infants, incompetents, or otherwise not sui juris.  
YOU ARE HEREBY NOTIFIED that an action has been commenced to foreclose a mortgage on the following real property, lying and being situated in Orange County, Florida, more particularly described as follows:  
LOT 100, BRYN MAWR UNIT 4, PHASE II, ACCORDING TO THE PLAT THEREOF, RECORDED IN PLAT BOOK 14, PAGE 26, OF THE PUBLIC RECORDS OF ORANGE COUNTY, FLORIDA more commonly known as 3150 Heathgate Ct. Orlando, Florida 32812.  
This action has been filed against you and you are required to serve a copy of your written defense, if any, upon BITMAN, O'BRIEN & MORAT, PLLC, Attorneys for Plaintiff, whose address is 255 Primera Blvd., Suite 128, Lake Mary, FL 32746, within thirty (30) days after the first publication of this notice and file the original with the Clerk of this Court either before service on Plaintiff's attorney or immediately thereafter; otherwise a default will be entered against you for the relief demanded in the Complaint.  
If you are a person with a disability who needs any accommodation in order to participate in this proceeding, you are entitled, at no cost to you, to the provision of certain assistance. Please contact Court Administration at 425 N. Orange Avenue, Room 2130, Orlando, Florida 32801, Telephone: (407) 836-2303 within two (2) working days of your receipt of this (describe notice); If you are hearing or voice impaired, call 1-800-955-8771.  
WITNESS my hand and seal of this Court on the 16 day of August, 2021.  
Tiffany Moore Russell  
Circuit and County Courts  
By: /s/ Maytee Moxley Deputy Clerk  
Civil Division  
425 N. Orange Avenue  
Room 350  
Orlando, Florida 32801  
September 2, 9, 2021 21-02997W

**SECOND INSERTION**

**NOTICE OF PUBLIC SALE OF PERSONAL PROPERTY**  
Please take notice SmartStop Self Storage located at 1071 Marshall Farms Rd, Ocoee, FL 34761, intends to hold an auction of the goods stored in the following units to satisfy the lien of the owner. The sale will occur as an online auction via www.selfstorageauction.com on 09/22/21 at 11:44am. Contents include personal property belonging to those individuals listed below.  
Unit# 1001 David Silva- Appliances, boxes, and clothing  
Unit# 1052- Areil Howell- Clothing, toys, boxes, and baby items  
Unit# 1088 Michael Bruce- Tools, electronics, and boxes  
Unit# 1149 Yvette Brown- bedding, boxes, furniture and electronics  
Unit# 3032 Latonya Arrington- Boxes, bags and totes  
Unit# 4083 Colton Baptiste- Electronics and boxes  
Purchases must be paid at the above referenced facility in order to complete the transaction. SmartStop Self Storage may refuse any bid and may rescind any purchase up until the winning bidder takes possession of the personal property.  
Please contact the property with any questions (407)-955-0609  
September 2, 9, 2021 21-03229W

**SECOND INSERTION**

**Notice of Self Storage Sale**  
Please take notice US Storage Centers - Orlando - Narcoossee located at 6707 Narcoossee Rd., Orlando FL 32822 intends to hold a sale to sell the property stored at the Facility by the below list of Occupants whom are in default at an Auction. The sale will occur as an online auction via www.storagecenters.com on 9/21/2021 at 10:00am. Unless stated otherwise the description of the contents are household goods and furnishings. John Velez unit #1002; Richard E Scott units #2101 & #2111; Angel Ulises Rivera Martinez unit #2116; Jennifer Silva unit #3005; Martin Santiago unit #3011; Jose Fuentes unit #3027; Noah Hanke unit #3051; Javier Merced Beltran unit #4001; Richard Lopeman unit #4024. This sale may be withdrawn at any time without notice. Certain terms and conditions apply. See manager for details.  
September 2, 9, 2021 21-03015W

**SECOND INSERTION**

**SALE NOTICE**  
In accordance with the provisions of State law, there being due and unpaid charges for which the undersigned is entitled to satisfy an owner and/or manager's lien of the goods hereinafter described and stored at the Life Storage location(s) listed below.  
And, due notice having been given, to the owner of said property and all parties known to claim an interest therein, and the time specified in such notice for payment of such having expired, the goods will be sold at public auction at the below stated location(s) to the highest bidder or otherwise disposed of on Monday, September 27th 2021 at 10:00 AM, 1236 Vineland Rd. Winter Garden, FL 34787 (407) 905-4949  
Customer Name Inventory  
Edens Richelieu Hsld gds/Furn  
Timothy Couch Hsld gds/Furn  
Quenchell Price Hsld gds/Furn  
Alexandre Siqueira Hsld gds/Furn  
Mario Howard Hsld gds/Fur  
September 2, 9, 2021 21-03230W

**SECOND INSERTION**

**Notice of Self Storage Sale**  
Please take notice US Storage Centers - Orlando - Sligh located at 924 Sligh Blvd., Orlando, FL 32806 intends to hold a sale to sell the property stored at the Facility by the below list of Occupants whom are in default at an Auction. The sale will occur as an online auction via www.storagecenters.com on 9/21/2021 at 10:00am. Unless stated otherwise the description of the contents are household goods and furnishings. Lavon Ivey Jr. unit #1137; Glynis Anthony unit #1227; Paris Johnson units #3136 & #3137; Rasheed Spears unit #3246; Devin T Eatou unit #6102; Jerome Alexander Thomas unit #6104. This sale may be withdrawn at any time without notice. Certain terms and conditions apply. See manager for details.  
September 2, 9, 2021 21-03016W

**SECOND INSERTION**

**SALE NOTICE**  
Notice is hereby given that Stoneybrook West Storage will sell the contents of the following self-storage units by public auction to satisfy their liens against these tenants, in accordance with the Florida Self-Storage Facility Act. The auction will take place at this location at 10:30 AM on Thursday, September 16th, 2021, or thereafter. Units are believed to contain household goods, unless otherwise listed.  
Stoneybrook West Storage  
1650 Avalon Rd.  
Winter Garden, FL 34787  
Phone: 407-654-3037  
It is assumed to be household goods, unless otherwise noted.  
Unit # Tenant Name  
343 Michael Collins  
September 2, 9, 2021 21-03018W

**THIRD INSERTION**

**NOTICE OF APPLICATION FOR TAX DEED**  
NOTICE IS HEREBY GIVEN that RAYMOND P RHODE the holder of the following certificate has filed said certificate for a TAX DEED to be issued thereon. The Certificate number and year of issuance, the description of the property, and the names in which it was assessed are as follows:  
CERTIFICATE NUMBER: 2014-24026  
YEAR OF ISSUANCE: 2014

**THIRD INSERTION**

**NOTICE OF APPLICATION FOR TAX DEED**  
NOTICE IS HEREBY GIVEN that RAYMOND P RHODE the holder of the following certificate has filed said certificate for a TAX DEED to be issued thereon. The Certificate number and year of issuance, the description of the property, and the names in which it was assessed are as follows:  
CERTIFICATE NUMBER: 2014-24077  
YEAR OF ISSUANCE: 2014

**THIRD INSERTION**

**NOTICE OF APPLICATION FOR TAX DEED**  
NOTICE IS HEREBY GIVEN that RE-LIANCE LOAN FUNDING LLC the holder of the following certificate has filed said certificate for a TAX DEED to be issued thereon. The Certificate number and year of issuance, the description of the property, and the names in which it was assessed are as follows:  
CERTIFICATE NUMBER: 2018-20182  
YEAR OF ISSUANCE: 2018

**THIRD INSERTION**

**NOTICE OF APPLICATION FOR TAX DEED**  
NOTICE IS HEREBY GIVEN that LESS S 205 FT THEREOF the holder of the following certificate has filed said certificate for a TAX DEED to be issued thereon. The Certificate number and year of issuance, the description of the property, and the names in which it was assessed are as follows:  
CERTIFICATE NUMBER: 2018-20182  
YEAR OF ISSUANCE: 2018

**THIRD INSERTION**

**NOTICE OF APPLICATION FOR TAX DEED**  
NOTICE IS HEREBY GIVEN that RAYMOND P RHODE the holder of the following certificate has filed said certificate for a TAX DEED to be issued thereon. The Certificate number and year of issuance, the description of the property, and the names in which it was assessed are as follows:  
CERTIFICATE NUMBER: 2014-23703  
YEAR OF ISSUANCE: 2014

**THIRD INSERTION**

**NOTICE OF APPLICATION FOR TAX DEED**  
NOTICE IS HEREBY GIVEN that RAYMOND P RHODE the holder of the following certificate has filed said certificate for a TAX DEED to be issued thereon. The Certificate number and year of issuance, the description of the property, and the names in which it was assessed are as follows:  
CERTIFICATE NUMBER: 2014-23703  
YEAR OF ISSUANCE: 2014

**THIRD INSERTION**

**NOTICE OF APPLICATION FOR TAX DEED**  
NOTICE IS HEREBY GIVEN that RAYMOND P RHODE the holder of the following certificate has filed said certificate for a TAX DEED to be issued thereon. The Certificate number and year of issuance, the description of the property, and the names in which it was assessed are as follows:  
CERTIFICATE NUMBER: 2014-23703  
YEAR OF ISSUANCE: 2014

**THIRD INSERTION**

**NOTICE OF APPLICATION FOR TAX DEED**  
NOTICE IS HEREBY GIVEN that RAYMOND P RHODE the holder of the following certificate has filed said certificate for a TAX DEED to be issued thereon. The Certificate number and year of issuance, the description of the property, and the names in which it was assessed are as follows:  
CERTIFICATE NUMBER: 2014-24077  
YEAR OF ISSUANCE: 2014

**THIRD INSERTION**

**NOTICE OF APPLICATION FOR TAX DEED**  
NOTICE IS HEREBY GIVEN that RAYMOND P RHODE the holder of the following certificate has filed said certificate for a TAX DEED to be issued thereon. The Certificate number and year of issuance, the description of the property, and the names in which it was assessed are as follows:  
CERTIFICATE NUMBER: 2014-24077  
YEAR OF ISSUANCE: 2014

**THIRD INSERTION**

**NOTICE OF APPLICATION FOR TAX DEED**  
NOTICE IS HEREBY GIVEN that RAYMOND P RHODE the holder of the following certificate has filed said certificate for a TAX DEED to be issued thereon. The Certificate number and year of issuance, the description of the property, and the names in which it was assessed are as follows:  
CERTIFICATE NUMBER: 2014-24077  
YEAR OF ISSUANCE: 2014

**THIRD INSERTION**

**NOTICE OF APPLICATION FOR TAX DEED**  
NOTICE IS HEREBY GIVEN that RAYMOND P RHODE the holder of the following certificate has filed said certificate for a TAX DEED to be issued thereon. The Certificate number and year of issuance, the description of the property, and the names in which it was assessed are as follows:  
CERTIFICATE NUMBER: 2014-23703  
YEAR OF ISSUANCE: 2014

**THIRD INSERTION**

**NOTICE OF APPLICATION FOR TAX DEED**  
NOTICE IS HEREBY GIVEN that RAYMOND P RHODE the holder of the following certificate has filed said certificate for a TAX DEED to be issued thereon. The Certificate number and year of issuance, the description of the property, and the names in which it was assessed are as follows:  
CERTIFICATE NUMBER: 2014-23703  
YEAR OF ISSUANCE: 2014

**THIRD INSERTION**

**NOTICE OF APPLICATION FOR TAX DEED**  
NOTICE IS HEREBY GIVEN that RAYMOND P RHODE the holder of the following certificate has filed said certificate for a TAX DEED to be issued thereon. The Certificate number and year of issuance, the description of the property, and the names in which it was assessed are as follows:  
CERTIFICATE NUMBER: 2014-23703  
YEAR OF ISSUANCE: 2014

**THIRD INSERTION**

**NOTICE OF APPLICATION FOR TAX DEED**  
NOTICE IS HEREBY GIVEN that RAYMOND P RHODE the holder of the following certificate has filed said certificate for a TAX DEED to be issued thereon. The Certificate number and year of issuance, the description of the property, and the names in which it was assessed are as follows:  
CERTIFICATE NUMBER: 2014-23703  
YEAR OF ISSUANCE: 2014

**THIRD INSERTION**

**NOTICE OF APPLICATION FOR TAX DEED**  
NOTICE IS HEREBY GIVEN that RAYMOND P RHODE the holder of the following certificate has filed said certificate for a TAX DEED to be issued thereon. The Certificate number and year of issuance, the description of the property, and the names in which it was assessed are as follows:  
CERTIFICATE NUMBER: 2014-23703  
YEAR OF ISSUANCE: 2014

**THIRD INSERTION**

**NOTICE OF APPLICATION FOR TAX DEED**  
NOTICE IS HEREBY GIVEN that RAYMOND P RHODE the holder of the following certificate has filed said certificate for a TAX DEED to be issued thereon. The Certificate number and year of issuance, the description of the property, and the names in which it was assessed are as follows:  
CERTIFICATE NUMBER: 2014-23703  
YEAR OF ISSUANCE: 2014

**THIRD INSERTION**

**NOTICE OF APPLICATION FOR TAX DEED**  
NOTICE IS HEREBY GIVEN that THORNTON MELLON LLC the holder of the following certificate has filed said certificate for a TAX DEED to be issued thereon. The Certificate number and year of issuance, the description of the property, and the names in which it was assessed are as follows:  
CERTIFICATE NUMBER: 2019-765  
YEAR OF ISSUANCE: 2019

**THIRD INSERTION**

**NOTICE OF APPLICATION FOR TAX DEED**  
NOTICE IS HEREBY GIVEN that KEYS TAX FUNDING LLC - 19 the holder of the following certificate has filed said certificate for a TAX DEED to be issued thereon. The Certificate number and year of issuance, the description of the property, and the names in which it was assessed are as follows:  
CERTIFICATE NUMBER: 2019-1222  
YEAR OF ISSUANCE: 2019

**THIRD INSERTION**

**NOTICE OF APPLICATION FOR TAX DEED**  
NOTICE IS HEREBY GIVEN that THORNTON MELLON LLC the holder of the following certificate has filed said certificate for a TAX DEED to be issued thereon. The Certificate number and year of issuance, the description of the property, and the names in which it was assessed are as follows:  
CERTIFICATE NUMBER: 2019-2528  
YEAR OF ISSUANCE: 2019

**THIRD INSERTION**

**NOTICE OF APPLICATION FOR TAX DEED**  
NOTICE IS HEREBY GIVEN that THORNTON MELLON LLC the holder of the following certificate has filed said certificate for a TAX DEED to be issued thereon. The Certificate number and year of issuance, the description of the property, and the names in which it was assessed are as follows:  
CERTIFICATE NUMBER: 2019-3094  
YEAR OF ISSUANCE: 2019

**THIRD INSERTION**

**NOTICE OF APPLICATION FOR TAX DEED**  
NOTICE IS HEREBY GIVEN that THORNTON MELLON LLC the holder of the following certificate has filed said certificate for a TAX DEED to be issued thereon. The Certificate number and year of issuance, the description of the property, and the names in which it was assessed are as follows:  
CERTIFICATE NUMBER: 2019-3849  
YEAR OF ISSUANCE: 2019

**THIRD INSERTION**

**NOTICE OF APPLICATION FOR TAX DEED**  
NOTICE IS HEREBY GIVEN that KEYS TAX FUNDING LLC - 19 the holder of the following certificate has filed said certificate for a TAX DEED to be issued thereon. The Certificate number and year of issuance, the description of the property, and the names in which it was assessed are as follows:  
CERTIFICATE NUMBER: 2019-3849  
YEAR OF ISSUANCE: 2019

Dated: Aug 19, 2021  
Phil Diamond  
County Comptroller  
Orange County, Florida  
By: M Hildebrandt  
Deputy Comptroller  
August 26; September 2, 9, 16, 2021  
21-02849W

Dated: Aug 19, 2021  
Phil Diamond  
County Comptroller  
Orange County, Florida  
By: M Hildebrandt  
Deputy Comptroller  
August 26; September 2, 9, 16, 2021  
21-02850W

Dated: Aug 19, 2021  
Phil Diamond  
County Comptroller  
Orange County, Florida  
By: M Hildebrandt  
Deputy Comptroller  
August 26; September 2, 9, 16, 2021  
21-02851W

Dated: Aug 19, 2021  
Phil Diamond  
County Comptroller  
Orange County, Florida  
By: M Hildebrandt  
Deputy Comptroller  
August 26; September 2, 9, 16, 2021  
21-02852W

Dated: Aug 19, 2021  
Phil Diamond  
County Comptroller  
Orange County, Florida  
By: M Hildebrandt  
Deputy Comptroller  
August 26; September 2, 9, 16, 2021  
21-02853W

Dated: Aug 19, 2021  
Phil Diamond  
County Comptroller  
Orange County, Florida  
By: M Hildebrandt  
Deputy Comptroller  
August 26; September 2, 9, 16, 2021  
21-02854W

**SAVE TIME - EMAIL YOUR LEGAL NOTICES**  
Sarasota County • Manatee County • Hillsborough County • Charlotte County • Pinellas County • Pasco County • Polk County • Lee County • Collier County • Orange County  
legal@businessobserverfl.com  
**Wednesday 2pm Deadline for Friday Publication | Wednesday 10am for Thursday Publication in Orange County**





**ORANGE COUNTY**  
**SUBSEQUENT INSERTIONS**

**THIRD INSERTION**

**NOTICE OF APPLICATION FOR TAX DEED**

NOTICE IS HEREBY GIVEN that KEYS TAX FUNDING LLC - 19 the holder of the following certificate has filed said certificate for a TAX DEED to be issued thereon. The Certificate number and year of issuance, the description of the property, and the names in which it was assessed are as follows:

CERTIFICATE NUMBER: 2019-4240

YEAR OF ISSUANCE: 2019

DESCRIPTION OF PROPERTY: THAT PT OF NW1/4 OF SEC 16-22-28 BEING DESC AS COMM AT W1/4 COR OF SAID SEC 16 TH N 233 FT E 180 FT TO POB CONT E 397 FT TO WLY R/W LINE SLY 49.77 FT SLY 49.83 FT S 94.23 FT TO N R/W LINE W 387 FT N 193.07 FT TO POB

PARCEL ID # 16-22-28-0000-00-042

Name in which assessed: CRYSTAL INVESTMENT GROUP LLC

ALL of said property being in the County of Orange, State of Florida. Unless such certificate shall be redeemed according to law, the property described in such certificate will be sold to the highest bidder online at [www.orange.realtaxdeed.com](http://www.orange.realtaxdeed.com) scheduled to begin at 10:00 a.m. ET, Oct 07, 2021.

Dated: Aug 19, 2021  
Phil Diamond  
County Comptroller  
Orange County, Florida  
By: M Hildebrandt  
Deputy Comptroller  
August 26; September 2, 9, 16, 2021  
21-02855W

**THIRD INSERTION**

**NOTICE OF APPLICATION FOR TAX DEED**

NOTICE IS HEREBY GIVEN that THORNTON MELLON LLC the holder of the following certificate has filed said certificate for a TAX DEED to be issued thereon. The Certificate number and year of issuance, the description of the property, and the names in which it was assessed are as follows:

CERTIFICATE NUMBER: 2019-8089

YEAR OF ISSUANCE: 2019

DESCRIPTION OF PROPERTY: CYPRESS POINTE AT LAKE ORLANDO CONDOMINIUM 8825/0505 UNIT 4014C

PARCEL ID # 05-22-29-1876-04-014

Name in which assessed: MARK MARINO, ELLA MARINO

ALL of said property being in the County of Orange, State of Florida. Unless such certificate shall be redeemed according to law, the property described in such certificate will be sold to the highest bidder online at [www.orange.realtaxdeed.com](http://www.orange.realtaxdeed.com) scheduled to begin at 10:00 a.m. ET, Oct 07, 2021.

Dated: Aug 19, 2021  
Phil Diamond  
County Comptroller  
Orange County, Florida  
By: M Hildebrandt  
Deputy Comptroller  
August 26; September 2, 9, 16, 2021  
21-02861W

**THIRD INSERTION**

**NOTICE OF APPLICATION FOR TAX DEED**

NOTICE IS HEREBY GIVEN that THORNTON MELLON LLC the holder of the following certificate has filed said certificate for a TAX DEED to be issued thereon. The Certificate number and year of issuance, the description of the property, and the names in which it was assessed are as follows:

CERTIFICATE NUMBER: 2019-12138

YEAR OF ISSUANCE: 2019

DESCRIPTION OF PROPERTY: TYMBER SKAN ON THE LAKE SECTION 1 CONDO CB 1/96 UNIT H BLDG 9

PARCEL ID # 09-23-29-9401-09-008

Name in which assessed: TYMBER SKAN ON THE LAKE MASTER HOMEOWNERS ASSN INC

ALL of said property being in the County of Orange, State of Florida. Unless such certificate shall be redeemed according to law, the property described in such certificate will be sold to the highest bidder online at [www.orange.realtaxdeed.com](http://www.orange.realtaxdeed.com) scheduled to begin at 10:00 a.m. ET, Oct 07, 2021.

Dated: Aug 19, 2021  
Phil Diamond  
County Comptroller  
Orange County, Florida  
By: M Hildebrandt  
Deputy Comptroller  
August 26; September 2, 9, 16, 2021  
21-02867W

**THIRD INSERTION**

**NOTICE OF APPLICATION FOR TAX DEED**

NOTICE IS HEREBY GIVEN that KEYS TAX FUNDING LLC - 19 the holder of the following certificate has filed said certificate for a TAX DEED to be issued thereon. The Certificate number and year of issuance, the description of the property, and the names in which it was assessed are as follows:

CERTIFICATE NUMBER: 2019-5212

YEAR OF ISSUANCE: 2019

DESCRIPTION OF PROPERTY: AZUR AT METROWEST CONDOMINIUM 8641/1867 UNIT 1203

PARCEL ID # 36-22-28-0199-12-030

Name in which assessed: AUSTRAL AMERICAN 21 LLC

ALL of said property being in the County of Orange, State of Florida. Unless such certificate shall be redeemed according to law, the property described in such certificate will be sold to the highest bidder online at [www.orange.realtaxdeed.com](http://www.orange.realtaxdeed.com) scheduled to begin at 10:00 a.m. ET, Oct 07, 2021.

Dated: Aug 19, 2021  
Phil Diamond  
County Comptroller  
Orange County, Florida  
By: M Hildebrandt  
Deputy Comptroller  
August 26; September 2, 9, 16, 2021  
21-02856W

**THIRD INSERTION**

**NOTICE OF APPLICATION FOR TAX DEED**

NOTICE IS HEREBY GIVEN that KEYS TAX FUNDING LLC - 19 the holder of the following certificate has filed said certificate for a TAX DEED to be issued thereon. The Certificate number and year of issuance, the description of the property, and the names in which it was assessed are as follows:

CERTIFICATE NUMBER: 2019-9019

YEAR OF ISSUANCE: 2019

DESCRIPTION OF PROPERTY: 7935/2857 ERROR IN LEGAL DESCRIPTION -- SILVER PINES GOLF VILLAGE CONDO 3022/1813 BLDG 6 UNIT 202

PARCEL ID # 18-22-29-8030-06-202

Name in which assessed: FLORIDIAN RENTAL 1 LLC

ALL of said property being in the County of Orange, State of Florida. Unless such certificate shall be redeemed according to law, the property described in such certificate will be sold to the highest bidder online at [www.orange.realtaxdeed.com](http://www.orange.realtaxdeed.com) scheduled to begin at 10:00 a.m. ET, Oct 07, 2021.

Dated: Aug 19, 2021  
Phil Diamond  
County Comptroller  
Orange County, Florida  
By: M Hildebrandt  
Deputy Comptroller  
August 26; September 2, 9, 16, 2021  
21-02862W

**THIRD INSERTION**

**NOTICE OF APPLICATION FOR TAX DEED**

NOTICE IS HEREBY GIVEN that THORNTON MELLON LLC the holder of the following certificate has filed said certificate for a TAX DEED to be issued thereon. The Certificate number and year of issuance, the description of the property, and the names in which it was assessed are as follows:

CERTIFICATE NUMBER: 2019-12196

YEAR OF ISSUANCE: 2019

DESCRIPTION OF PROPERTY: TYMBER SKAN ON THE LAKE SECTION 3 CONDO CB 2/51 UNIT H BLDG 49

PARCEL ID # 09-23-29-9403-49-008

Name in which assessed: MICHAEL SMITH, TAWANDA SMITH

ALL of said property being in the County of Orange, State of Florida. Unless such certificate shall be redeemed according to law, the property described in such certificate will be sold to the highest bidder online at [www.orange.realtaxdeed.com](http://www.orange.realtaxdeed.com) scheduled to begin at 10:00 a.m. ET, Oct 07, 2021.

Dated: Aug 19, 2021  
Phil Diamond  
County Comptroller  
Orange County, Florida  
By: M Hildebrandt  
Deputy Comptroller  
August 26; September 2, 9, 16, 2021  
21-02868W

**THIRD INSERTION**

**NOTICE OF APPLICATION FOR TAX DEED**

NOTICE IS HEREBY GIVEN that THORNTON MELLON LLC the holder of the following certificate has filed said certificate for a TAX DEED to be issued thereon. The Certificate number and year of issuance, the description of the property, and the names in which it was assessed are as follows:

CERTIFICATE NUMBER: 2019-5563

YEAR OF ISSUANCE: 2019

DESCRIPTION OF PROPERTY: OFFICES AT VERANDA PARK BUILDING 1000 7507/1400 UNIT 214

PARCEL ID # 02-23-28-6124-00-214

Name in which assessed: DEVELOPCO INC

ALL of said property being in the County of Orange, State of Florida. Unless such certificate shall be redeemed according to law, the property described in such certificate will be sold to the highest bidder online at [www.orange.realtaxdeed.com](http://www.orange.realtaxdeed.com) scheduled to begin at 10:00 a.m. ET, Oct 07, 2021.

Dated: Aug 19, 2021  
Phil Diamond  
County Comptroller  
Orange County, Florida  
By: M Hildebrandt  
Deputy Comptroller  
August 26; September 2, 9, 16, 2021  
21-02857W

**THIRD INSERTION**

**NOTICE OF APPLICATION FOR TAX DEED**

NOTICE IS HEREBY GIVEN that ATCF II FLORIDA-A LLC the holder of the following certificate has filed said certificate for a TAX DEED to be issued thereon. The Certificate number and year of issuance, the description of the property, and the names in which it was assessed are as follows:

CERTIFICATE NUMBER: 2019-9664

YEAR OF ISSUANCE: 2019

DESCRIPTION OF PROPERTY: HAMMOND & BUNCH SECOND ADDITION D/54 THE W 56 FT OF E 221 FT OF N 100 FT OF LOT 10

PARCEL ID # 26-22-29-3304-00-104

Name in which assessed: BETTYE GELZER

ALL of said property being in the County of Orange, State of Florida. Unless such certificate shall be redeemed according to law, the property described in such certificate will be sold to the highest bidder online at [www.orange.realtaxdeed.com](http://www.orange.realtaxdeed.com) scheduled to begin at 10:00 a.m. ET, Oct 07, 2021.

Dated: Aug 19, 2021  
Phil Diamond  
County Comptroller  
Orange County, Florida  
By: M Hildebrandt  
Deputy Comptroller  
August 26; September 2, 9, 16, 2021  
21-02863W

**THIRD INSERTION**

**NOTICE OF APPLICATION FOR TAX DEED**

NOTICE IS HEREBY GIVEN that KEYS TAX FUNDING LLC - 19 the holder of the following certificate has filed said certificate for a TAX DEED to be issued thereon. The Certificate number and year of issuance, the description of the property, and the names in which it was assessed are as follows:

CERTIFICATE NUMBER: 2019-14065

YEAR OF ISSUANCE: 2019

DESCRIPTION OF PROPERTY: PARKWAY DISTRIBUTION CENTER PHASE 2 CONDO CB 13/45 UNIT 8

PARCEL ID # 11-24-29-6712-00-080

Name in which assessed: SIMON JOHN NEEDHAM

ALL of said property being in the County of Orange, State of Florida. Unless such certificate shall be redeemed according to law, the property described in such certificate will be sold to the highest bidder online at [www.orange.realtaxdeed.com](http://www.orange.realtaxdeed.com) scheduled to begin at 10:00 a.m. ET, Oct 07, 2021.

Dated: Aug 19, 2021  
Phil Diamond  
County Comptroller  
Orange County, Florida  
By: M Hildebrandt  
Deputy Comptroller  
August 26; September 2, 9, 16, 2021  
21-02869W

**THIRD INSERTION**

**NOTICE OF APPLICATION FOR TAX DEED**

NOTICE IS HEREBY GIVEN that KEYS TAX FUNDING LLC - 19 the holder of the following certificate has filed said certificate for a TAX DEED to be issued thereon. The Certificate number and year of issuance, the description of the property, and the names in which it was assessed are as follows:

CERTIFICATE NUMBER: 2019-5725

YEAR OF ISSUANCE: 2019

DESCRIPTION OF PROPERTY: STONEBRIDGE LAKES CONDO PH 13 7656/2 UNIT 102 BLDG 13

PARCEL ID # 12-23-28-8179-13-102

Name in which assessed: QIN LIN

ALL of said property being in the County of Orange, State of Florida. Unless such certificate shall be redeemed according to law, the property described in such certificate will be sold to the highest bidder online at [www.orange.realtaxdeed.com](http://www.orange.realtaxdeed.com) scheduled to begin at 10:00 a.m. ET, Oct 07, 2021.

Dated: Aug 19, 2021  
Phil Diamond  
County Comptroller  
Orange County, Florida  
By: M Hildebrandt  
Deputy Comptroller  
August 26; September 2, 9, 16, 2021  
21-02858W

**THIRD INSERTION**

**NOTICE OF APPLICATION FOR TAX DEED**

NOTICE IS HEREBY GIVEN that THORNTON MELLON LLC the holder of the following certificate has filed said certificate for a TAX DEED to be issued thereon. The Certificate number and year of issuance, the description of the property, and the names in which it was assessed are as follows:

CERTIFICATE NUMBER: 2019-9760

YEAR OF ISSUANCE: 2019

DESCRIPTION OF PROPERTY: CLEAR LAKE SUB Q/97 LOT 2

PARCEL ID # 27-22-29-1372-00-020

Name in which assessed: AZULES INVESTMENTS LLC

ALL of said property being in the County of Orange, State of Florida. Unless such certificate shall be redeemed according to law, the property described in such certificate will be sold to the highest bidder online at [www.orange.realtaxdeed.com](http://www.orange.realtaxdeed.com) scheduled to begin at 10:00 a.m. ET, Oct 07, 2021.

Dated: Aug 19, 2021  
Phil Diamond  
County Comptroller  
Orange County, Florida  
By: M Hildebrandt  
Deputy Comptroller  
August 26; September 2, 9, 16, 2021  
21-02864W

**THIRD INSERTION**

**NOTICE OF APPLICATION FOR TAX DEED**

NOTICE IS HEREBY GIVEN that THORNTON MELLON LLC the holder of the following certificate has filed said certificate for a TAX DEED to be issued thereon. The Certificate number and year of issuance, the description of the property, and the names in which it was assessed are as follows:

CERTIFICATE NUMBER: 2019-17012

YEAR OF ISSUANCE: 2019

DESCRIPTION OF PROPERTY: LAKE MARGARET TERRACE 1ST ADD W/51 LOT 4 BLK I

PARCEL ID # 08-23-30-4632-09-040

Name in which assessed: BERTHA J DREW

ALL of said property being in the County of Orange, State of Florida. Unless such certificate shall be redeemed according to law, the property described in such certificate will be sold to the highest bidder online at [www.orange.realtaxdeed.com](http://www.orange.realtaxdeed.com) scheduled to begin at 10:00 a.m. ET, Oct 07, 2021.

Dated: Aug 19, 2021  
Phil Diamond  
County Comptroller  
Orange County, Florida  
By: M Hildebrandt  
Deputy Comptroller  
August 26; September 2, 9, 16, 2021  
21-02870W

**THIRD INSERTION**

**NOTICE OF APPLICATION FOR TAX DEED**

NOTICE IS HEREBY GIVEN that KEYS TAX FUNDING LLC - 19 the holder of the following certificate has filed said certificate for a TAX DEED to be issued thereon. The Certificate number and year of issuance, the description of the property, and the names in which it was assessed are as follows:

CERTIFICATE NUMBER: 2019-6370

YEAR OF ISSUANCE: 2019

DESCRIPTION OF PROPERTY: GRANADA VILLAS PHASE 4 19/111 LOT 112 (LESS E1/2)

PARCEL ID # 34-23-28-3142-01-120

Name in which assessed: DAVID OREILLY, NICOLE OREILLY

ALL of said property being in the County of Orange, State of Florida. Unless such certificate shall be redeemed according to law, the property described in such certificate will be sold to the highest bidder online at [www.orange.realtaxdeed.com](http://www.orange.realtaxdeed.com) scheduled to begin at 10:00 a.m. ET, Oct 07, 2021.

Dated: Aug 19, 2021  
Phil Diamond  
County Comptroller  
Orange County, Florida  
By: M Hildebrandt  
Deputy Comptroller  
August 26; September 2, 9, 16, 2021  
21-02859W

**THIRD INSERTION**

**NOTICE OF APPLICATION FOR TAX DEED**

NOTICE IS HEREBY GIVEN that THORNTON MELLON LLC the holder of the following certificate has filed said certificate for a TAX DEED to be issued thereon. The Certificate number and year of issuance, the description of the property, and the names in which it was assessed are as follows:

CERTIFICATE NUMBER: 2019-11925

YEAR OF ISSUANCE: 2019

DESCRIPTION OF PROPERTY: MID-DLEBROOK PINES CONDO PHASE 29 3430/899 BLDG 29 UNIT 305

PARCEL ID # 07-23-29-5650-29-305

Name in which assessed: HASSAN EL-BOUATMANI, LAILA OULHOTE

ALL of said property being in the County of Orange, State of Florida. Unless such certificate shall be redeemed according to law, the property described in such certificate will be sold to the highest bidder online at [www.orange.realtaxdeed.com](http://www.orange.realtaxdeed.com) scheduled to begin at 10:00 a.m. ET, Oct 07, 2021.

Dated: Aug 19, 2021  
Phil Diamond  
County Comptroller  
Orange County, Florida  
By: M Hildebrandt  
Deputy Comptroller  
August 26; September 2, 9, 16, 2021  
21-02865W

**THIRD INSERTION**

**NOTICE OF APPLICATION FOR TAX DEED**

NOTICE IS HEREBY GIVEN that KEYS TAX FUNDING LLC - 19 the holder of the following certificate has filed said certificate for a TAX DEED to be issued thereon. The Certificate number and year of issuance, the description of the property, and the names in which it was assessed are as follows:

CERTIFICATE NUMBER: 2019-17284

YEAR OF ISSUANCE: 2019

DESCRIPTION OF PROPERTY: VENETIAN PLACE CONDOMINIUM 8755/1712 UNIT 1815 BLDG 18

PARCEL ID # 10-23-30-8908-01-815

Name in which assessed: ATLANTY DISTRIBUTOR 1 CORP

ALL of said property being in the County of Orange, State of Florida. Unless such certificate shall be redeemed according to law, the property described in such certificate will be sold to the highest bidder online at [www.orange.realtaxdeed.com](http://www.orange.realtaxdeed.com) scheduled to begin at 10:00 a.m. ET, Oct 07, 2021.

Dated: Aug 19, 2021  
Phil Diamond  
County Comptroller  
Orange County, Florida  
By: M Hildebrandt  
Deputy Comptroller  
August 26; September 2, 9, 16, 2021  
21-02871W

**THIRD INSERTION**

**NOTICE OF APPLICATION FOR TAX DEED**

NOTICE IS HEREBY GIVEN that THORNTON MELLON LLC the holder of the following certificate has filed said certificate for a TAX DEED to be issued thereon. The Certificate number and year of issuance, the description of the property, and the names in which it was assessed are as follows:

CERTIFICATE NUMBER: 2019-7722

YEAR OF ISSUANCE: 2019

DESCRIPTION OF PROPERTY: PARK LAKE SHORES V/31 LOT 12

PARCEL ID # 36-21-29-6672-00-120

Name in which assessed: BENJAMIN PARTNERS LTD

ALL of said property being in the County of Orange, State of Florida. Unless such certificate shall be redeemed according to law, the property described in such certificate will be sold to the highest bidder online at [www.orange.realtaxdeed.com](http://www.orange.realtaxdeed.com) scheduled to begin at 10:00 a.m. ET, Oct 07, 2021.

Dated: Aug 19, 2021  
Phil Diamond  
County Comptroller  
Orange County, Florida  
By: M Hildebrandt  
Deputy Comptroller  
August 26; September 2, 9, 16, 2021  
21-02860W

**THIRD INSERTION**

**NOTICE OF APPLICATION FOR TAX DEED**

NOTICE IS HEREBY GIVEN that THORNTON MELLON LLC the holder of the following certificate has filed said certificate for a TAX DEED to be issued thereon. The Certificate number and year of issuance, the description of the property, and the names in which it was assessed are as follows:

CERTIFICATE NUMBER: 2019-12099

YEAR OF ISSUANCE: 2019

DESCRIPTION OF PROPERTY: LEMON TREE SECTION 6 CONDO CB 10/35 BLDG 32 UNIT 3203

PARCEL ID # 09-23-29-4998-33-203

Name in which assessed: RICHARD L MINGO

ALL of said property being in the County of Orange, State of Florida. Unless such certificate shall be redeemed according to law, the property described in such certificate will be sold to the highest bidder online at [www.orange.realtaxdeed.com](http://www.orange.realtaxdeed.com) scheduled to begin at 10:00 a.m. ET, Oct 07, 2021.

Dated: Aug 19, 2021  
Phil Diamond  
County Comptroller  
Orange County, Florida  
By: M Hildebrandt  
Deputy Comptroller  
August 26; September 2, 9, 16, 2021  
21-02866W

# ORANGE COUNTY

## SUBSEQUENT INSERTIONS

### THIRD INSERTION

#### NOTICE OF ACTION FOR PUBLICATION IN THE CIRCUIT COURT OF THE NINTH JUDICIAL CIRCUIT IN AND FOR ORANGE COUNTY, FLORIDA

**Case No.: 2019-DR-016784-O**  
 ADALIZ MELENDEZ SANTOS, Petitioner,  
 v.  
 JAVIER JOSE CORA SIERRA, Respondent.  
 TO: ADALIZ MELENDEZ SANTOS, 10259 Lake District Lane, Orlando, FL 32832

YOU ARE HEREBY NOTIFIED that an action for Relocation has been filed against you and that you are required to serve a copy of your written defenses, if any, to it on Irene B. Pons, Esquire, attorney for Petitioner, whose address is 3564 Avalon Park Blvd, E. Ste. 1 #124, Orlando, FL 32828 on or before 10/14/2021, and file the original with the Orange County Clerk of Court, 425 N Orange Avenue, Orlando, FL before service on Petitioner or immediately thereafter.

If you fail to do so, a default may be entered against you for the relief demanded in the petition. Copies of all court documents in this case, including orders, are available at the Clerk of the Circuit Court's office. You may review these documents upon request.

You must keep the Clerk of the Circuit Court's office notified of your current address. (You may file Notice of Current Address, Florida Supreme Court Approved Family Law Form 12.915.) Future papers in this lawsuit will be mailed to the address on record at the clerk's office.

WARNING: Rule 12.285, Florida Family Law Rules of Procedure, requires certain automatic disclosure of documents and information. Failure to comply can result in sanctions, including dismissal or striking of pleadings.

DATED: 8/19/2021  
 TIFFANY MOORE RUSSELL  
 CLERK OF THE CIRCUIT COURT  
 By: /s/Felicia Sanders  
 DEPUTY CLERK  
 425 North Orange Ave.  
 Suite 320  
 Orlando, Florida 32801  
 Aug. 26; Sep. 2, 9, 16, 2021  
 21-02919W

### FOURTH INSERTION

#### NOTICE OF APPLICATION FOR TAX DEED

NOTICE IS HEREBY GIVEN that BIANCA MERCEDES DIAZ the holder of the following certificate has filed said certificate for a TAX DEED to be issued thereon. The Certificate number and year of issuance, the description of the property, and the names in which it was assessed are as follows:

CERTIFICATE NUMBER: 2018-6173  
 YEAR OF ISSUANCE: 2018

DESCRIPTION OF PROPERTY: PARKSIDE PHASE 2 82/53 LOT 173  
 PARCEL ID # 10-24-28-6654-01-730

Name in which assessed:  
 MG ITALY LLC

ALL of said property being in the County of Orange, State of Florida. Unless such certificate shall be redeemed according to law, the property described in such certificate will be sold to the highest bidder online at [www.orange.realtaxdeed.com](http://www.orange.realtaxdeed.com) scheduled to begin at 10:00 a.m. ET, Sep 30, 2021.

Dated: Aug 12, 2021  
 Phil Diamond  
 County Comptroller  
 Orange County, Florida  
 By: R Kane  
 Deputy Comptroller  
 August 19, 26; September 2, 9, 2021  
 21-02732W

### FOURTH INSERTION

#### NOTICE OF APPLICATION FOR TAX DEED

NOTICE IS HEREBY GIVEN that THORNTON MELLON LLC the holder of the following certificate has filed said certificate for a TAX DEED to be issued thereon. The Certificate number and year of issuance, the description of the property, and the names in which it was assessed are as follows:

CERTIFICATE NUMBER: 2019-137  
 YEAR OF ISSUANCE: 2019

DESCRIPTION OF PROPERTY: S1/2 OF SE1/4 OF SE1/4 OF SE1/4 OF SEC 16-20-27 (LESS S 30 FT & E 30 FT FOR RD R/W)

PARCEL ID # 16-20-27-0000-00-031  
 Name in which assessed:  
 SANG BONG LEE, SUN LEE

ALL of said property being in the County of Orange, State of Florida. Unless such certificate shall be redeemed according to law, the property described in such certificate will be sold to the highest bidder online at [www.orange.realtaxdeed.com](http://www.orange.realtaxdeed.com) scheduled to begin at 10:00 a.m. ET, Sep 30, 2021.

Dated: Aug 12, 2021  
 Phil Diamond  
 County Comptroller  
 Orange County, Florida  
 By: R Kane  
 Deputy Comptroller  
 August 19, 26; September 2, 9, 2021  
 21-02733W

### FOURTH INSERTION

#### NOTICE OF APPLICATION FOR TAX DEED

NOTICE IS HEREBY GIVEN that THORNTON MELLON LLC the holder of the following certificate has filed said certificate for a TAX DEED to be issued thereon. The Certificate number and year of issuance, the description of the property, and the names in which it was assessed are as follows:

CERTIFICATE NUMBER: 2019-564  
 YEAR OF ISSUANCE: 2019

DESCRIPTION OF PROPERTY: MARY JEAN SUB Q/61 LOT 16 BLK B  
 PARCEL ID # 13-22-27-5528-02-160

Name in which assessed:  
 LORETTA FLOWERS

ALL of said property being in the County of Orange, State of Florida. Unless such certificate shall be redeemed according to law, the property described in such certificate will be sold to the highest bidder online at [www.orange.realtaxdeed.com](http://www.orange.realtaxdeed.com) scheduled to begin at 10:00 a.m. ET, Sep 30, 2021.

Dated: Aug 12, 2021  
 Phil Diamond  
 County Comptroller  
 Orange County, Florida  
 By: R Kane  
 Deputy Comptroller  
 August 19, 26; September 2, 9, 2021  
 21-02734W

### FOURTH INSERTION

#### NOTICE OF APPLICATION FOR TAX DEED

NOTICE IS HEREBY GIVEN that THORNTON MELLON LLC the holder of the following certificate has filed said certificate for a TAX DEED to be issued thereon. The Certificate number and year of issuance, the description of the property, and the names in which it was assessed are as follows:

CERTIFICATE NUMBER: 2019-2068  
 YEAR OF ISSUANCE: 2019

DESCRIPTION OF PROPERTY: SWEETWATER COUNTRY CLUB SECTION C PHASE 1 12/54 TRACT D (LESS PT DESC IN BEG AT THE NW CORNER OF TRACT E TH S3-8-11E 208.88 FT ALONG W LINE OF SAID TRACT E TH S23-9-31W 27.3 FT ALONG THE NLY LINE OF TRACT C TH DEPARTING SAID NLY LINE S81-54-8E 127.03 FT TH N86-51-49E 105 FT TH N79-38-33E 100.8 FT TH S60-28-59E 56.9 FT TH S72-26-12E 67.13 FT TH S89-18-3E 49.41 FT TH N83-16-30E 53.42 FT TH N71-3-13E 32.45 FT TH N68-56-16E 137.11 FT TH S35-49-44W 26.58 FT TH S0-34-4W 95.66 FT TH S11-11-15W 31.27 FT TH S78-48-45E 58.79 FT TH S89-25-56E 251.02 FT TH N0-34-4E 25.03 FT TH S89-25-56E 301.8 FT TH N0-34-4E 553.41 FT TH N89-25-56W 2.53 FT TH N53-8-48W 96.84 FT TH N34-27-16W 42.33 FT TH N21-30-14W 20 FT TH N1-24-52E 34.35 FT TH N15-0-46E 100 FT TH N74-59-14W 156.91 FT TO THE WLY LINE OF TRACT B TH S15-0-46W 58.02 FT ALONG SAID WLY LINE OF TRACT C TO THE SW CORNER OF TRACT B TH RUN THE FOLLOWING COURSES ALONG TH NLY LINE OF TRACT D & THE NLY LINE OF TRACT E N74-59-14W 163.76 FT TO PT OF CURVE CONCAVE SLY HAV RAD OF 165 FT & CENTRAL ANGLE OF 58-52-49 & CHORD BEARING OF S75-34-21W TH ALONG SAID CURVE 169.56 FT TH S46-7-57W 291.58 FT TO PT OF CURVE CONCAVE NWLY HAV RAD OF 835 FT & CENTRAL ANGLE OF 39-48-18 & CHORD BEARING OF S66-2-6W TH ALONG SAID CURVE 580.1 FT TO POB)

PARCEL ID # 36-20-28-8466-00-004  
 Name in which assessed:  
 SWEETWATER GOLF AND COUNTRY CLUB INC

ALL of said property being in the County of Orange, State of Florida. Unless such certificate shall be redeemed according to law, the property described in such certificate will be sold to the highest bidder online at [www.orange.realtaxdeed.com](http://www.orange.realtaxdeed.com) scheduled to begin at 10:00 a.m. ET, Sep 30, 2021.

Dated: Aug 12, 2021  
 Phil Diamond  
 County Comptroller  
 Orange County, Florida  
 By: R Kane  
 Deputy Comptroller  
 August 19, 26; September 2, 9, 2021  
 21-02735W

### FOURTH INSERTION

#### NOTICE OF APPLICATION FOR TAX DEED

NOTICE IS HEREBY GIVEN that THORNTON MELLON LLC the holder of the following certificate has filed said certificate for a TAX DEED to be issued thereon. The Certificate number and year of issuance, the description of the property, and the names in which it was assessed are as follows:

CERTIFICATE NUMBER: 2019-2069  
 YEAR OF ISSUANCE: 2019

DESCRIPTION OF PROPERTY: SWEETWATER COUNTRY CLUB SECTION C PHASE 1 12/54 TRACT E (LESS PT DESC IN BEG AT THE NW CORNER OF TRACT E TH S3-8-11E 208.88 FT ALONG W LINE OF SAID TRACT E TH S23-9-31W 27.3 FT ALONG THE NLY LINE OF TRACT C TH DEPARTING SAID NLY LINE S81-54-8E 127.03 FT TH N86-51-49E 105 FT TH N79-38-33E 100.8 FT TH S60-28-59E 56.9 FT TH S72-26-12E 67.13 FT TH S89-18-3E 49.41 FT TH N83-16-30E 53.42 FT TH N71-3-13E 32.45 FT TH N68-56-16E 137.11 FT TH S35-49-44W 26.58 FT TH S0-34-4W 95.66 FT TH S11-11-15W 31.27 FT TH S78-48-45E 58.79 FT TH S89-25-56E 251.02 FT TH N0-34-4E 25.03 FT TH S89-25-56E 301.8 FT TH N0-34-4E 553.41 FT TH N89-25-56W 2.53 FT TH N53-8-48W 96.84 FT TH N34-27-16W 42.33 FT TH N21-30-14W 20 FT TH N1-24-52E 34.35 FT TH N15-0-46E 100 FT TH N74-59-14W 156.91 FT TO THE WLY LINE OF TRACT B TH S15-0-46W 58.02 FT ALONG SAID WLY LINE OF TRACT C TO THE SW CORNER OF TRACT B TH RUN THE FOLLOWING COURSES ALONG TH NLY LINE OF TRACT D & THE NLY LINE OF TRACT E N74-59-14W 163.76 FT TO PT OF CURVE CONCAVE SLY HAV RAD OF 165 FT & CENTRAL ANGLE OF 58-52-49 & CHORD BEARING OF S75-34-21W TH ALONG SAID CURVE 169.56 FT TH S46-7-57W 291.58 FT TO PT OF CURVE CONCAVE NWLY HAV RAD OF 835 FT & CENTRAL ANGLE OF 39-48-18 & CHORD BEARING OF S66-2-6W TH ALONG SAID CURVE 580.1 FT TO POB)

PARCEL ID # 36-20-28-8466-00-005  
 Name in which assessed: SWEETWATER GOLF AND COUNTRY CLUB INC

ALL of said property being in the County of Orange, State of Florida. Unless such certificate shall be redeemed according to law, the property described in such certificate will be sold to the highest bidder online at [www.orange.realtaxdeed.com](http://www.orange.realtaxdeed.com) scheduled to begin at 10:00 a.m. ET, Sep 30, 2021.

Dated: Aug 12, 2021  
 Phil Diamond  
 County Comptroller  
 Orange County, Florida  
 By: R Kane  
 Deputy Comptroller  
 August 19, 26; September 2, 9, 2021  
 21-02736W

### FOURTH INSERTION

#### NOTICE OF APPLICATION FOR TAX DEED

NOTICE IS HEREBY GIVEN that THORNTON MELLON LLC the holder of the following certificate has filed said certificate for a TAX DEED to be issued thereon. The Certificate number and year of issuance, the description of the property, and the names in which it was assessed are as follows:

CERTIFICATE NUMBER: 2019-2396  
 YEAR OF ISSUANCE: 2019

DESCRIPTION OF PROPERTY: TOWN OF APOPKA A/109 FROM SW COR OF LOT 71 BLK H RUN N 76 FT FOR POB TH RUN N 90.33 FT E 21 FT S 49 DEG E 35.98 FT S 2 DEG W 67.62 FT W 45.30 FT TO POB IN SEC 16-21-28 NE1/4

PARCEL ID # 09-21-28-0196-80-711  
 Name in which assessed:  
 DANYIEL YARBROUGH

ALL of said property being in the County of Orange, State of Florida. Unless such certificate shall be redeemed according to law, the property described in such certificate will be sold to the highest bidder online at [www.orange.realtaxdeed.com](http://www.orange.realtaxdeed.com) scheduled to begin at 10:00 a.m. ET, Sep 30, 2021.

Dated: Aug 12, 2021  
 Phil Diamond  
 County Comptroller  
 Orange County, Florida  
 By: R Kane  
 Deputy Comptroller  
 August 19, 26; September 2, 9, 2021  
 21-02737W

### FOURTH INSERTION

#### NOTICE OF APPLICATION FOR TAX DEED

NOTICE IS HEREBY GIVEN that THORNTON MELLON LLC the holder of the following certificate has filed said certificate for a TAX DEED to be issued thereon. The Certificate number and year of issuance, the description of the property, and the names in which it was assessed are as follows:

CERTIFICATE NUMBER: 2019-3286  
 YEAR OF ISSUANCE: 2019

DESCRIPTION OF PROPERTY: YOGI BEARS JELLYSTONE PK CAMP RESORT (APOPKA) 3347/2482 UNIT 602

PARCEL ID # 27-21-28-9805-00-602  
 Name in which assessed:  
 ROBERT OVERMAN

ALL of said property being in the County of Orange, State of Florida. Unless such certificate shall be redeemed according to law, the property described in such certificate will be sold to the highest bidder online at [www.orange.realtaxdeed.com](http://www.orange.realtaxdeed.com) scheduled to begin at 10:00 a.m. ET, Sep 30, 2021.

Dated: Aug 12, 2021  
 Phil Diamond  
 County Comptroller  
 Orange County, Florida  
 By: R Kane  
 Deputy Comptroller  
 August 19, 26; September 2, 9, 2021  
 21-02738W

### FOURTH INSERTION

#### NOTICE OF APPLICATION FOR TAX DEED

NOTICE IS HEREBY GIVEN that FORTIS INVESTMENTS the holder of the following certificate has filed said certificate for a TAX DEED to be issued thereon. The Certificate number and year of issuance, the description of the property, and the names in which it was assessed are as follows:

CERTIFICATE NUMBER: 2019-5562  
 YEAR OF ISSUANCE: 2019

DESCRIPTION OF PROPERTY: OFFICES AT VERANDA PARK BUILDING 1000 7507/1400 UNIT 213

PARCEL ID # 02-23-28-6124-00-213  
 Name in which assessed:  
 DEVELOPCO INC

ALL of said property being in the County of Orange, State of Florida. Unless such certificate shall be redeemed according to law, the property described in such certificate will be sold to the highest bidder online at [www.orange.realtaxdeed.com](http://www.orange.realtaxdeed.com) scheduled to begin at 10:00 a.m. ET, Sep 30, 2021.

Dated: Aug 12, 2021  
 Phil Diamond  
 County Comptroller  
 Orange County, Florida  
 By: R Kane  
 Deputy Comptroller  
 August 19, 26; September 2, 9, 2021  
 21-02739W

## OFFICIAL COURT HOUSE WEBSITES:

**MANATEE COUNTY:**  
manateeclerk.com

**SARASOTA COUNTY:**  
sarasotaclerk.com

**CHARLOTTE COUNTY:**  
charlotte.realforeclose.com

**LEE COUNTY:**  
leeclerk.org

**COLLIER COUNTY:**  
collierclerk.com

**HILLSBOROUGH COUNTY:**  
hillsclerk.com

**PASCO COUNTY:**  
pasco.realforeclose.com

**PINELLAS COUNTY:**  
pinellasclerk.org

**POLK COUNTY:**  
polkcountyclerk.net

**ORANGE COUNTY:**  
myorangeclerk.com

Check out your notices on:  
[floridapublicnotices.com](http://floridapublicnotices.com)

Business Observer

LV10245

## WHEN PUBLIC NOTICES REACH THE PUBLIC, EVERYONE BENEFITS.

Some officials want to move notices from newspapers to government-run websites, where they may not be easily found.

Why try to fix something that isn't broken?

?

2 OUT OF 3

U.S. adults read a newspaper in print or online during the week.

www.newsmediaalliance.org

Keep Public Notices in Newspapers.

## WHEN PUBLIC NOTICES REACH THE PUBLIC, EVERYONE BENEFITS.

Some officials want to move notices from newspapers to government-run websites, where they may not be easily found.

This is like putting the fox in charge of the hen house.

www.newsmediaalliance.org

Keep Public Notices in Newspapers

# ORANGE COUNTY

## SUBSEQUENT INSERTIONS

**FOURTH INSERTION**

**NOTICE OF APPLICATION FOR TAX DEED**

NOTICE IS HEREBY GIVEN that FORTIS INVESTMENTS the holder of the following certificate has filed said certificate for a TAX DEED to be issued thereon. The Certificate number and year of issuance, the description of the property, and the names in which it was assessed are as follows:

CERTIFICATE NUMBER: 2019-5807

YEAR OF ISSUANCE: 2019

DESCRIPTION OF PROPERTY: WINDERMERE BUSINESS CENTER CONDOMINIUM 9741/6450 UNIT 412

PARCEL ID # 12-23-28-8606-00-412

Name in which assessed: ORLANDO SMILES INC

ALL of said property being in the County of Orange, State of Florida. Unless such certificate shall be redeemed according to law, the property described in such certificate will be sold to the highest bidder online at www.orange.realtaxdeed.com scheduled to begin at 10:00 a.m. ET, Sep 30, 2021.

Dated: Aug 12, 2021  
Phil Diamond  
County Comptroller  
Orange County, Florida  
By: R Kane  
Deputy Comptroller  
August 19, 26; September 2, 9, 2021  
21-02740W

**FOURTH INSERTION**

**NOTICE OF APPLICATION FOR TAX DEED**

NOTICE IS HEREBY GIVEN that THORNTON MELLON LLC the holder of the following certificate has filed said certificate for a TAX DEED to be issued thereon. The Certificate number and year of issuance, the description of the property, and the names in which it was assessed are as follows:

CERTIFICATE NUMBER: 2019-6924

YEAR OF ISSUANCE: 2019

DESCRIPTION OF PROPERTY: LAKE BUENA VISTA RESORT VILLAGE 3 CONDOMINIUM 9613/3369 UNIT 4406

PARCEL ID # 35-24-28-4359-04-406

Name in which assessed: LAKE BUENA VISTA RESORT LLC

ALL of said property being in the County of Orange, State of Florida. Unless such certificate shall be redeemed according to law, the property described in such certificate will be sold to the highest bidder online at www.orange.realtaxdeed.com scheduled to begin at 10:00 a.m. ET, Sep 30, 2021.

Dated: Aug 12, 2021  
Phil Diamond  
County Comptroller  
Orange County, Florida  
By: R Kane  
Deputy Comptroller  
August 19, 26; September 2, 9, 2021  
21-02746W

**FOURTH INSERTION**

**NOTICE OF APPLICATION FOR TAX DEED**

NOTICE IS HEREBY GIVEN that THORNTON MELLON LLC the holder of the following certificate has filed said certificate for a TAX DEED to be issued thereon. The Certificate number and year of issuance, the description of the property, and the names in which it was assessed are as follows:

CERTIFICATE NUMBER: 2019-9968

YEAR OF ISSUANCE: 2019

DESCRIPTION OF PROPERTY: OLD WINTER GARDEN ROAD COMMERCE CENTER CONDO 7465/2020 UNIT 11 BLDG 2

PARCEL ID # 28-22-29-6164-02-110

Name in which assessed: GEETA PERSAUD

ALL of said property being in the County of Orange, State of Florida. Unless such certificate shall be redeemed according to law, the property described in such certificate will be sold to the highest bidder online at www.orange.realtaxdeed.com scheduled to begin at 10:00 a.m. ET, Sep 30, 2021.

Dated: Aug 12, 2021  
Phil Diamond  
County Comptroller  
Orange County, Florida  
By: R Kane  
Deputy Comptroller  
August 19, 26; September 2, 9, 2021  
21-02752W

**FOURTH INSERTION**

**NOTICE OF APPLICATION FOR TAX DEED**

NOTICE IS HEREBY GIVEN that THORNTON MELLON LLC the holder of the following certificate has filed said certificate for a TAX DEED to be issued thereon. The Certificate number and year of issuance, the description of the property, and the names in which it was assessed are as follows:

CERTIFICATE NUMBER: 2019-6404

YEAR OF ISSUANCE: 2019

DESCRIPTION OF PROPERTY: SAND LAKE PRIVATE RESIDENCES CONDO 7827/2548 CB 35/112 UNIT 2211 BLDG 2

PARCEL ID # 35-23-28-7837-02-211

Name in which assessed: IVAN LOPEZ MARTINEZ, BERTHA NINOSKA ORTEGA DE LOPEZ

ALL of said property being in the County of Orange, State of Florida. Unless such certificate shall be redeemed according to law, the property described in such certificate will be sold to the highest bidder online at www.orange.realtaxdeed.com scheduled to begin at 10:00 a.m. ET, Sep 30, 2021.

Dated: Aug 12, 2021  
Phil Diamond  
County Comptroller  
Orange County, Florida  
By: R Kane  
Deputy Comptroller  
August 19, 26; September 2, 9, 2021  
21-02741W

**FOURTH INSERTION**

**NOTICE OF APPLICATION FOR TAX DEED**

NOTICE IS HEREBY GIVEN that THORNTON MELLON LLC the holder of the following certificate has filed said certificate for a TAX DEED to be issued thereon. The Certificate number and year of issuance, the description of the property, and the names in which it was assessed are as follows:

CERTIFICATE NUMBER: 2019-7107

YEAR OF ISSUANCE: 2019

DESCRIPTION OF PROPERTY: MAGNOLIA COURT CONDOMINIUM 8469/2032 UNIT A BLDG 1

PARCEL ID # 28-21-29-5429-01-010

Name in which assessed: A MAN AROUND THE HOUSE LLC

ALL of said property being in the County of Orange, State of Florida. Unless such certificate shall be redeemed according to law, the property described in such certificate will be sold to the highest bidder online at www.orange.realtaxdeed.com scheduled to begin at 10:00 a.m. ET, Sep 30, 2021.

Dated: Aug 12, 2021  
Phil Diamond  
County Comptroller  
Orange County, Florida  
By: R Kane  
Deputy Comptroller  
August 19, 26; September 2, 9, 2021  
21-02747W

**FOURTH INSERTION**

**NOTICE OF APPLICATION FOR TAX DEED**

NOTICE IS HEREBY GIVEN that MIKON FINANCIAL SERVICES INC AND OCEAN BANK the holder of the following certificate has filed said certificate for a TAX DEED to be issued thereon. The Certificate number and year of issuance, the description of the property, and the names in which it was assessed are as follows:

CERTIFICATE NUMBER: 2019-10095

YEAR OF ISSUANCE: 2019

DESCRIPTION OF PROPERTY: MALIBU GROVES THIRD ADDITION 2/60 LOT 39

PARCEL ID # 29-22-29-5486-00-390

Name in which assessed: MAE FRANCES HARP ESTATE

ALL of said property being in the County of Orange, State of Florida. Unless such certificate shall be redeemed according to law, the property described in such certificate will be sold to the highest bidder online at www.orange.realtaxdeed.com scheduled to begin at 10:00 a.m. ET, Sep 30, 2021.

Dated: Aug 12, 2021  
Phil Diamond  
County Comptroller  
Orange County, Florida  
By: R Kane  
Deputy Comptroller  
August 19, 26; September 2, 9, 2021  
21-02753W

**FOURTH INSERTION**

**NOTICE OF APPLICATION FOR TAX DEED**

NOTICE IS HEREBY GIVEN that THORNTON MELLON LLC the holder of the following certificate has filed said certificate for a TAX DEED to be issued thereon. The Certificate number and year of issuance, the description of the property, and the names in which it was assessed are as follows:

CERTIFICATE NUMBER: 2019-6584

YEAR OF ISSUANCE: 2019

DESCRIPTION OF PROPERTY: PARC CORNICHE CONDO PHASE 1 CB 16/94 UNIT 1107 BLDG 1

PARCEL ID # 13-24-28-6649-11-070

Name in which assessed: YOUSEF MUSLEH

ALL of said property being in the County of Orange, State of Florida. Unless such certificate shall be redeemed according to law, the property described in such certificate will be sold to the highest bidder online at www.orange.realtaxdeed.com scheduled to begin at 10:00 a.m. ET, Sep 30, 2021.

Dated: Aug 12, 2021  
Phil Diamond  
County Comptroller  
Orange County, Florida  
By: R Kane  
Deputy Comptroller  
August 19, 26; September 2, 9, 2021  
21-02742W

**FOURTH INSERTION**

**NOTICE OF APPLICATION FOR TAX DEED**

NOTICE IS HEREBY GIVEN that THORNTON MELLON LLC the holder of the following certificate has filed said certificate for a TAX DEED to be issued thereon. The Certificate number and year of issuance, the description of the property, and the names in which it was assessed are as follows:

CERTIFICATE NUMBER: 2019-7119

YEAR OF ISSUANCE: 2019

DESCRIPTION OF PROPERTY: MAGNOLIA COURT CONDOMINIUM 8469/2032 UNIT D BLDG 7

PARCEL ID # 28-21-29-5429-07-040

Name in which assessed: TERESITA DE LA CARIDAD SILVA

ALL of said property being in the County of Orange, State of Florida. Unless such certificate shall be redeemed according to law, the property described in such certificate will be sold to the highest bidder online at www.orange.realtaxdeed.com scheduled to begin at 10:00 a.m. ET, Sep 30, 2021.

Dated: Aug 12, 2021  
Phil Diamond  
County Comptroller  
Orange County, Florida  
By: R Kane  
Deputy Comptroller  
August 19, 26; September 2, 9, 2021  
21-02748W

**FOURTH INSERTION**

**NOTICE OF APPLICATION FOR TAX DEED**

NOTICE IS HEREBY GIVEN that THORNTON MELLON LLC the holder of the following certificate has filed said certificate for a TAX DEED to be issued thereon. The Certificate number and year of issuance, the description of the property, and the names in which it was assessed are as follows:

CERTIFICATE NUMBER: 2019-11451

YEAR OF ISSUANCE: 2019

DESCRIPTION OF PROPERTY: ANGEILT ADDITION NO 2 J/124 LOT 20 BLK 102

PARCEL ID # 03-23-29-0183-12-200

Name in which assessed: HARLEY R FISHER ESTATE

ALL of said property being in the County of Orange, State of Florida. Unless such certificate shall be redeemed according to law, the property described in such certificate will be sold to the highest bidder online at www.orange.realtaxdeed.com scheduled to begin at 10:00 a.m. ET, Sep 30, 2021.

Dated: Aug 12, 2021  
Phil Diamond  
County Comptroller  
Orange County, Florida  
By: R Kane  
Deputy Comptroller  
August 19, 26; September 2, 9, 2021  
21-02754W

**FOURTH INSERTION**

**NOTICE OF APPLICATION FOR TAX DEED**

NOTICE IS HEREBY GIVEN that THORNTON MELLON LLC the holder of the following certificate has filed said certificate for a TAX DEED to be issued thereon. The Certificate number and year of issuance, the description of the property, and the names in which it was assessed are as follows:

CERTIFICATE NUMBER: 2019-6603

YEAR OF ISSUANCE: 2019

DESCRIPTION OF PROPERTY: PARC CORNICHE CONDO PH 2 CB 16/138 UNIT 4305 BLDG 4

PARCEL ID # 13-24-28-6655-04-305

Name in which assessed: MARIANA JORGELINA DAL MOLIN

ALL of said property being in the County of Orange, State of Florida. Unless such certificate shall be redeemed according to law, the property described in such certificate will be sold to the highest bidder online at www.orange.realtaxdeed.com scheduled to begin at 10:00 a.m. ET, Sep 30, 2021.

Dated: Aug 12, 2021  
Phil Diamond  
County Comptroller  
Orange County, Florida  
By: R Kane  
Deputy Comptroller  
August 19, 26; September 2, 9, 2021  
21-02743W

**FOURTH INSERTION**

**NOTICE OF APPLICATION FOR TAX DEED**

NOTICE IS HEREBY GIVEN that THORNTON MELLON LLC the holder of the following certificate has filed said certificate for a TAX DEED to be issued thereon. The Certificate number and year of issuance, the description of the property, and the names in which it was assessed are as follows:

CERTIFICATE NUMBER: 2019-7151

YEAR OF ISSUANCE: 2019

DESCRIPTION OF PROPERTY: MAGNOLIA COURT CONDOMINIUM 8469/2032 UNIT D BLDG 22

PARCEL ID # 28-21-29-5429-22-040

Name in which assessed: DEGEN AGNEW

ALL of said property being in the County of Orange, State of Florida. Unless such certificate shall be redeemed according to law, the property described in such certificate will be sold to the highest bidder online at www.orange.realtaxdeed.com scheduled to begin at 10:00 a.m. ET, Sep 30, 2021.

Dated: Aug 12, 2021  
Phil Diamond  
County Comptroller  
Orange County, Florida  
By: R Kane  
Deputy Comptroller  
August 19, 26; September 2, 9, 2021  
21-02749W

**FOURTH INSERTION**

**NOTICE OF APPLICATION FOR TAX DEED**

NOTICE IS HEREBY GIVEN that THORNTON MELLON LLC the holder of the following certificate has filed said certificate for a TAX DEED to be issued thereon. The Certificate number and year of issuance, the description of the property, and the names in which it was assessed are as follows:

CERTIFICATE NUMBER: 2019-11489

YEAR OF ISSUANCE: 2019

DESCRIPTION OF PROPERTY: CLEAR LAKE VIEWS J/145 LOTS 6 & 7 & W 5 FT OF LOT 5 BLK 3

PARCEL ID # 03-23-29-1402-03-060

Name in which assessed: SHPETIM HARXHI

ALL of said property being in the County of Orange, State of Florida. Unless such certificate shall be redeemed according to law, the property described in such certificate will be sold to the highest bidder online at www.orange.realtaxdeed.com scheduled to begin at 10:00 a.m. ET, Sep 30, 2021.

Dated: Aug 12, 2021  
Phil Diamond  
County Comptroller  
Orange County, Florida  
By: R Kane  
Deputy Comptroller  
August 19, 26; September 2, 9, 2021  
21-02755W

**FOURTH INSERTION**

**NOTICE OF APPLICATION FOR TAX DEED**

NOTICE IS HEREBY GIVEN that THORNTON MELLON LLC the holder of the following certificate has filed said certificate for a TAX DEED to be issued thereon. The Certificate number and year of issuance, the description of the property, and the names in which it was assessed are as follows:

CERTIFICATE NUMBER: 2019-6647

YEAR OF ISSUANCE: 2019

DESCRIPTION OF PROPERTY: GOLDEN OAK PHASE 1B 75/3 LOT 20

PARCEL ID # 18-24-28-3102-00-200

Name in which assessed: GOLDEN OAK HOLDINGS LLC

ALL of said property being in the County of Orange, State of Florida. Unless such certificate shall be redeemed according to law, the property described in such certificate will be sold to the highest bidder online at www.orange.realtaxdeed.com scheduled to begin at 10:00 a.m. ET, Sep 30, 2021.

Dated: Aug 12, 2021  
Phil Diamond  
County Comptroller  
Orange County, Florida  
By: R Kane  
Deputy Comptroller  
August 19, 26; September 2, 9, 2021  
21-02744W

**FOURTH INSERTION**

**NOTICE OF APPLICATION FOR TAX DEED**

NOTICE IS HEREBY GIVEN that THORNTON MELLON LLC the holder of the following certificate has filed said certificate for a TAX DEED to be issued thereon. The Certificate number and year of issuance, the description of the property, and the names in which it was assessed are as follows:

CERTIFICATE NUMBER: 2019-7251

YEAR OF ISSUANCE: 2019

DESCRIPTION OF PROPERTY: AVON VISTA M/58 BEG AT SE COR LOT 8 BLK I RUN N 51 DEG W 8 FT N 38 DEG E 140 FT S 51 DEG E 168.67 FT SWLY 145.65 FT W TO CENTER VAC R/W NELY 52.53 FT NWLY TO POB BEING PARTS OF BLKS G & I & VAC R/W (LESS BEING A PT ON SWLY LINE OF LOT 2 BLK G OF AVON VISTA TH W 123.26 FT N 5 DEG W 107.32 FT S 51 DEG E 140 S 38 DEG W 171.99 FT TO POB) SEE 2404/84

PARCEL ID # 30-21-29-0348-09-090

Name in which assessed: SAAMS COMMERCIAL PROPERTY INC

ALL of said property being in the County of Orange, State of Florida. Unless such certificate shall be redeemed according to law, the property described in such certificate will be sold to the highest bidder online at www.orange.realtaxdeed.com scheduled to begin at 10:00 a.m. ET, Sep 30, 2021.

Dated: Aug 12, 2021  
Phil Diamond  
County Comptroller  
Orange County, Florida  
By: R Kane  
Deputy Comptroller  
August 19, 26; September 2, 9, 2021  
21-02750W

**FOURTH INSERTION**

**NOTICE OF APPLICATION FOR TAX DEED**

NOTICE IS HEREBY GIVEN that THORNTON MELLON LLC the holder of the following certificate has filed said certificate for a TAX DEED to be issued thereon. The Certificate number and year of issuance, the description of the property, and the names in which it was assessed are as follows:

CERTIFICATE NUMBER: 2019-11527

YEAR OF ISSUANCE: 2019

DESCRIPTION OF PROPERTY: RIO GRANDE TERRACE 6TH ADD X/141 LOT 14 BLK G

PARCEL ID # 03-23-29-7436-07-140

Name in which assessed: JOSE G CABREJA

ALL of said property being in the County of Orange, State of Florida. Unless such certificate shall be redeemed according to law, the property described in such certificate will be sold to the highest bidder online at www.orange.realtaxdeed.com scheduled to begin at 10:00 a.m. ET, Sep 30, 2021.

Dated: Aug 12, 2021  
Phil Diamond  
County Comptroller  
Orange County, Florida  
By: R Kane  
Deputy Comptroller  
August 19, 26; September 2, 9, 2021  
21-02756W

**FOURTH INSERTION**

**NOTICE OF APPLICATION FOR TAX DEED**

NOTICE IS HEREBY GIVEN that THORNTON MELLON LLC the holder of the following certificate has filed said certificate for a TAX DEED to be issued thereon. The Certificate number and year of issuance, the description of the property, and the names in which it was assessed are as follows:

CERTIFICATE NUMBER: 2019-6799

YEAR OF ISSUANCE: 2019

DESCRIPTION OF PROPERTY: BLUE HERON BEACH RESORT TOWER 1 CONDOMINIUM 8446/1530 UNIT 804

PARCEL ID # 27-24-28-0647-00-804

Name in which assessed: ROBERT D GARDNER, NATALIE K GARDNER

ALL of said property being in the County of Orange, State of Florida. Unless such certificate shall be redeemed according to law, the property described in such certificate will be sold to the highest bidder online at www.orange.realtaxdeed.com scheduled to begin at 10:00 a.m. ET, Sep 30, 2021.

Dated: Aug 12, 2021  
Phil Diamond  
County Comptroller  
Orange County, Florida  
By: R Kane  
Deputy Comptroller  
August 19, 26; September 2, 9, 2021  
21-02745W

**FOURTH INSERTION**

**NOTICE OF APPLICATION FOR TAX DEED**

NOTICE IS HEREBY GIVEN that MIKON FINANCIAL SERVICES INC AND OCEAN BANK the holder of the following certificate has filed said certificate for a TAX DEED to be issued thereon. The Certificate number and year of issuance, the description of the property, and the names in which it was assessed are as follows:

CERTIFICATE NUMBER: 2019-7807

YEAR OF ISSUANCE: 2019

DESCRIPTION OF PROPERTY: HOME ACRES M/97 S 16 2/3 FT OF LOT 13 & ALL LOT 14 BLK P

PARCEL ID # 01-22-29-3712-16-131

Name in which assessed: BENJAMIN PARTNERS LTD

ALL of said property being in the County of Orange, State of Florida. Unless such certificate shall be redeemed according to law, the property described in such certificate will be sold to the highest bidder online at www.orange.realtaxdeed.com scheduled to begin at 10:00 a.m. ET, Sep 30, 2021.

Dated: Aug 12, 2021  
Phil Diamond  
County Comptroller  
Orange County, Florida  
By: R Kane  
Deputy Comptroller  
August 19, 26; September 2, 9, 2021  
21-02751W

**FOURTH INSERTION**

**NOTICE OF APPLICATION FOR TAX DEED**

NOTICE IS HEREBY GIVEN that MIKON FINANCIAL SERVICES INC AND OCEAN BANK the holder of the following certificate has filed said certificate for a TAX DEED to be issued thereon. The Certificate number and year of issuance, the description of the property, and the names in which it was assessed are as follows:

CERTIFICATE NUMBER: 2019-11562

YEAR OF ISSUANCE: 2019

DESCRIPTION OF PROPERTY: CATALINA ISLES CONDOMINIUM 9137/0983 UNIT 2765-A

PARCEL ID # 04-23-29-1227-27-651

Name in which assessed: BENJAMIN J ALLEN ESTATE

ALL of said property being in the County of Orange, State of Florida. Unless such certificate shall be redeemed according to law, the property described in such certificate will be sold to the highest bidder online at www.orange.realtaxdeed.com scheduled to begin at 10:00 a.m. ET, Sep 30, 2021.

Dated: Aug 12, 2021  
Phil Diamond  
County Comptroller  
Orange County, Florida  
By: R Kane  
Deputy Comptroller  
August 19, 26; September 2, 9, 2021  
21-02757W

**ORANGE COUNTY  
SUBSEQUENT INSERTIONS**

**FOURTH INSERTION**  
**NOTICE OF APPLICATION FOR TAX DEED**  
 NOTICE IS HEREBY GIVEN that MIKON FINANCIAL SERVICES INC AND OCEAN BANK the holder of the following certificate has filed said certificate for a TAX DEED to be issued thereon. The Certificate number and year of issuance, the description of the property, and the names in which it was assessed are as follows:  
 CERTIFICATE NUMBER: 2019-11889  
 YEAR OF ISSUANCE: 2019  
 DESCRIPTION OF PROPERTY: PALMS CLUB CONDOMINIUM 9007/2138 UNIT 107 BLDG 7  
 PARCEL ID # 06-23-29-6603-07-107  
 Name in which assessed: ROSANGELA SPERLE DA SILVA, PEDRO HENRIQUE SPERLE DA SILVA AZEVEDO, JOAO VICTOR SPERLE DA SILVA AZEVEDO  
 ALL of said property being in the County of Orange, State of Florida. Unless such certificate shall be redeemed according to law, the property described in such certificate will be sold to the highest bidder online at www.orange.realtaxdeed.com scheduled to begin at 10:00 a.m. ET, Sep 30, 2021.  
 Dated: Aug 12, 2021  
 Phil Diamond  
 County Comptroller  
 Orange County, Florida  
 By: R Kane  
 Deputy Comptroller  
 August 19, 26; September 2, 9, 2021  
 21-02758W

**FOURTH INSERTION**  
**NOTICE OF APPLICATION FOR TAX DEED**  
 NOTICE IS HEREBY GIVEN that SAVVY FL LLC the holder of the following certificate has filed said certificate for a TAX DEED to be issued thereon. The Certificate number and year of issuance, the description of the property, and the names in which it was assessed are as follows:  
 CERTIFICATE NUMBER: 2019-13094  
 YEAR OF ISSUANCE: 2019  
 DESCRIPTION OF PROPERTY: W R ANNOS ADD TO PINECASTLE F/53 LOTS 5 & 6 BLK 20  
 PARCEL ID # 24-23-29-0192-20-050  
 Name in which assessed: CARLOS F ARAUJO  
 ALL of said property being in the County of Orange, State of Florida. Unless such certificate shall be redeemed according to law, the property described in such certificate will be sold to the highest bidder online at www.orange.realtaxdeed.com scheduled to begin at 10:00 a.m. ET, Sep 30, 2021.  
 Dated: Aug 12, 2021  
 Phil Diamond  
 County Comptroller  
 Orange County, Florida  
 By: R Kane  
 Deputy Comptroller  
 August 19, 26; September 2, 9, 2021  
 21-02764W

**FOURTH INSERTION**  
**NOTICE OF APPLICATION FOR TAX DEED**  
 NOTICE IS HEREBY GIVEN that MIKON FINANCIAL SERVICES INC AND OCEAN BANK the holder of the following certificate has filed said certificate for a TAX DEED to be issued thereon. The Certificate number and year of issuance, the description of the property, and the names in which it was assessed are as follows:  
 CERTIFICATE NUMBER: 2019-16345  
 YEAR OF ISSUANCE: 2019  
 DESCRIPTION OF PROPERTY: THE VILLAS OF COSTA DEL SOL 10/25 LOT 263  
 PARCEL ID # 34-22-30-8890-02-630  
 Name in which assessed: JEAN AMERICA RIVERA  
 ALL of said property being in the County of Orange, State of Florida. Unless such certificate shall be redeemed according to law, the property described in such certificate will be sold to the highest bidder online at www.orange.realtaxdeed.com scheduled to begin at 10:00 a.m. ET, Sep 30, 2021.  
 Dated: Aug 12, 2021  
 Phil Diamond  
 County Comptroller  
 Orange County, Florida  
 By: R Kane  
 Deputy Comptroller  
 August 19, 26; September 2, 9, 2021  
 21-02770W

**FOURTH INSERTION**  
**NOTICE OF APPLICATION FOR TAX DEED**  
 NOTICE IS HEREBY GIVEN that THORNTON MELLON LLC the holder of the following certificate has filed said certificate for a TAX DEED to be issued thereon. The Certificate number and year of issuance, the description of the property, and the names in which it was assessed are as follows:  
 CERTIFICATE NUMBER: 2019-12100  
 YEAR OF ISSUANCE: 2019  
 DESCRIPTION OF PROPERTY: LEMON TREE SECTION 7 CONDO CB 11/5 UNIT 201 BLDG 2  
 PARCEL ID # 09-23-29-5000-02-201  
 Name in which assessed: AHMAD M AL-SUBAGHA  
 ALL of said property being in the County of Orange, State of Florida. Unless such certificate shall be redeemed according to law, the property described in such certificate will be sold to the highest bidder online at www.orange.realtaxdeed.com scheduled to begin at 10:00 a.m. ET, Sep 30, 2021.  
 Dated: Aug 12, 2021  
 Phil Diamond  
 County Comptroller  
 Orange County, Florida  
 By: R Kane  
 Deputy Comptroller  
 August 19, 26; September 2, 9, 2021  
 21-02759W

**FOURTH INSERTION**  
**NOTICE OF APPLICATION FOR TAX DEED**  
 NOTICE IS HEREBY GIVEN that THORNTON MELLON LLC the holder of the following certificate has filed said certificate for a TAX DEED to be issued thereon. The Certificate number and year of issuance, the description of the property, and the names in which it was assessed are as follows:  
 CERTIFICATE NUMBER: 2019-13306  
 YEAR OF ISSUANCE: 2019  
 DESCRIPTION OF PROPERTY: SANDLAKE COURTYARDS CONDO 5901/3515 UNIT 1076 BLDG 4  
 PARCEL ID # 27-23-29-8012-01-076  
 Name in which assessed: PATRICIA ALESANDRA CURCOVEZKI  
 ALL of said property being in the County of Orange, State of Florida. Unless such certificate shall be redeemed according to law, the property described in such certificate will be sold to the highest bidder online at www.orange.realtaxdeed.com scheduled to begin at 10:00 a.m. ET, Sep 30, 2021.  
 Dated: Aug 12, 2021  
 Phil Diamond  
 County Comptroller  
 Orange County, Florida  
 By: R Kane  
 Deputy Comptroller  
 August 19, 26; September 2, 9, 2021  
 21-02765W

**FOURTH INSERTION**  
**NOTICE OF APPLICATION FOR TAX DEED**  
 NOTICE IS HEREBY GIVEN that THORNTON MELLON LLC the holder of the following certificate has filed said certificate for a TAX DEED to be issued thereon. The Certificate number and year of issuance, the description of the property, and the names in which it was assessed are as follows:  
 CERTIFICATE NUMBER: 2019-16691  
 YEAR OF ISSUANCE: 2019  
 DESCRIPTION OF PROPERTY: MIRIADA CONDOMINIUM 8595/1954 UNIT 2053N  
 PARCEL ID # 04-23-30-5639-53-140  
 Name in which assessed: EQUITY TRUST CO CUSTODIAN  
 ALL of said property being in the County of Orange, State of Florida. Unless such certificate shall be redeemed according to law, the property described in such certificate will be sold to the highest bidder online at www.orange.realtaxdeed.com scheduled to begin at 10:00 a.m. ET, Sep 30, 2021.  
 Dated: Aug 12, 2021  
 Phil Diamond  
 County Comptroller  
 Orange County, Florida  
 By: R Kane  
 Deputy Comptroller  
 August 19, 26; September 2, 9, 2021  
 21-02771W

**FOURTH INSERTION**  
**NOTICE OF APPLICATION FOR TAX DEED**  
 NOTICE IS HEREBY GIVEN that THORNTON MELLON LLC the holder of the following certificate has filed said certificate for a TAX DEED to be issued thereon. The Certificate number and year of issuance, the description of the property, and the names in which it was assessed are as follows:  
 CERTIFICATE NUMBER: 2019-12130  
 YEAR OF ISSUANCE: 2019  
 DESCRIPTION OF PROPERTY: TYMBER SKAN ON THE LAKE SECTION 1 CONDO CB 1/96 UNIT D BLDG 1  
 PARCEL ID # 09-23-29-9401-01-004  
 Name in which assessed: MEI TAN MING, SHENG TAN MING, ZHUANG TAN MING  
 ALL of said property being in the County of Orange, State of Florida. Unless such certificate shall be redeemed according to law, the property described in such certificate will be sold to the highest bidder online at www.orange.realtaxdeed.com scheduled to begin at 10:00 a.m. ET, Sep 30, 2021.  
 Dated: Aug 12, 2021  
 Phil Diamond  
 County Comptroller  
 Orange County, Florida  
 By: R Kane  
 Deputy Comptroller  
 August 19, 26; September 2, 9, 2021  
 21-02760W

**FOURTH INSERTION**  
**NOTICE OF APPLICATION FOR TAX DEED**  
 NOTICE IS HEREBY GIVEN that THORNTON MELLON LLC the holder of the following certificate has filed said certificate for a TAX DEED to be issued thereon. The Certificate number and year of issuance, the description of the property, and the names in which it was assessed are as follows:  
 CERTIFICATE NUMBER: 2019-13330  
 YEAR OF ISSUANCE: 2019  
 DESCRIPTION OF PROPERTY: SANDLAKE COURTYARDS CONDO 5901/3515 UNIT 2020 BLDG 1  
 PARCEL ID # 27-23-29-8012-02-020  
 Name in which assessed: JEOVANNY LEVY REYES  
 ALL of said property being in the County of Orange, State of Florida. Unless such certificate shall be redeemed according to law, the property described in such certificate will be sold to the highest bidder online at www.orange.realtaxdeed.com scheduled to begin at 10:00 a.m. ET, Sep 30, 2021.  
 Dated: Aug 12, 2021  
 Phil Diamond  
 County Comptroller  
 Orange County, Florida  
 By: R Kane  
 Deputy Comptroller  
 August 19, 26; September 2, 9, 2021  
 21-02766W

**FOURTH INSERTION**  
**NOTICE OF APPLICATION FOR TAX DEED**  
 NOTICE IS HEREBY GIVEN that THORNTON MELLON LLC the holder of the following certificate has filed said certificate for a TAX DEED to be issued thereon. The Certificate number and year of issuance, the description of the property, and the names in which it was assessed are as follows:  
 CERTIFICATE NUMBER: 2019-17067  
 YEAR OF ISSUANCE: 2019  
 DESCRIPTION OF PROPERTY: REGENCY GARDENS CONDOMINIUM 8476/0291 UNIT 212 BLDG G  
 PARCEL ID # 09-23-30-7331-07-212  
 Name in which assessed: CUMULUS MANAGEMENT LP  
 ALL of said property being in the County of Orange, State of Florida. Unless such certificate shall be redeemed according to law, the property described in such certificate will be sold to the highest bidder online at www.orange.realtaxdeed.com scheduled to begin at 10:00 a.m. ET, Sep 30, 2021.  
 Dated: Aug 12, 2021  
 Phil Diamond  
 County Comptroller  
 Orange County, Florida  
 By: R Kane  
 Deputy Comptroller  
 August 19, 26; September 2, 9, 2021  
 21-02772W

**FOURTH INSERTION**  
**NOTICE OF APPLICATION FOR TAX DEED**  
 NOTICE IS HEREBY GIVEN that THORNTON MELLON LLC the holder of the following certificate has filed said certificate for a TAX DEED to be issued thereon. The Certificate number and year of issuance, the description of the property, and the names in which it was assessed are as follows:  
 CERTIFICATE NUMBER: 2019-12154  
 YEAR OF ISSUANCE: 2019  
 DESCRIPTION OF PROPERTY: TYMBER SKAN ON THE LAKE SECTION 2 CONDO CB 1/126 UNIT H BLDG 15  
 PARCEL ID # 09-23-29-9402-15-008  
 Name in which assessed: TYMBER SKAN ON THE LAKE OWNERS ASSN SEC TWO INC  
 ALL of said property being in the County of Orange, State of Florida. Unless such certificate shall be redeemed according to law, the property described in such certificate will be sold to the highest bidder online at www.orange.realtaxdeed.com scheduled to begin at 10:00 a.m. ET, Sep 30, 2021.  
 Dated: Aug 12, 2021  
 Phil Diamond  
 County Comptroller  
 Orange County, Florida  
 By: R Kane  
 Deputy Comptroller  
 August 19, 26; September 2, 9, 2021  
 21-02761W

**FOURTH INSERTION**  
**NOTICE OF APPLICATION FOR TAX DEED**  
 NOTICE IS HEREBY GIVEN that FORTIS INVESTMENTS the holder of the following certificate has filed said certificate for a TAX DEED to be issued thereon. The Certificate number and year of issuance, the description of the property, and the names in which it was assessed are as follows:  
 CERTIFICATE NUMBER: 2019-13963  
 YEAR OF ISSUANCE: 2019  
 DESCRIPTION OF PROPERTY: MONTPELIER VILLAGE PHASE 1 8/41 LOT 351  
 PARCEL ID # 07-24-29-5713-03-510  
 Name in which assessed: DAVID L WILBUR, MARTHA L WILBUR  
 ALL of said property being in the County of Orange, State of Florida. Unless such certificate shall be redeemed according to law, the property described in such certificate will be sold to the highest bidder online at www.orange.realtaxdeed.com scheduled to begin at 10:00 a.m. ET, Sep 30, 2021.  
 Dated: Aug 12, 2021  
 Phil Diamond  
 County Comptroller  
 Orange County, Florida  
 By: R Kane  
 Deputy Comptroller  
 August 19, 26; September 2, 9, 2021  
 21-02767W

**FOURTH INSERTION**  
**NOTICE OF APPLICATION FOR TAX DEED**  
 NOTICE IS HEREBY GIVEN that THORNTON MELLON LLC the holder of the following certificate has filed said certificate for a TAX DEED to be issued thereon. The Certificate number and year of issuance, the description of the property, and the names in which it was assessed are as follows:  
 CERTIFICATE NUMBER: 2019-17203  
 YEAR OF ISSUANCE: 2019  
 DESCRIPTION OF PROPERTY: SOUTHPOINTE UNIT 1 CONDO CB 8/65 BLDG 15 UNIT L1  
 PARCEL ID # 10-23-30-8182-15-101  
 Name in which assessed: LUIS GONZALEZ  
 ALL of said property being in the County of Orange, State of Florida. Unless such certificate shall be redeemed according to law, the property described in such certificate will be sold to the highest bidder online at www.orange.realtaxdeed.com scheduled to begin at 10:00 a.m. ET, Sep 30, 2021.  
 Dated: Aug 12, 2021  
 Phil Diamond  
 County Comptroller  
 Orange County, Florida  
 By: R Kane  
 Deputy Comptroller  
 August 19, 26; September 2, 9, 2021  
 21-02773W

**FOURTH INSERTION**  
**NOTICE OF APPLICATION FOR TAX DEED**  
 NOTICE IS HEREBY GIVEN that THORNTON MELLON LLC the holder of the following certificate has filed said certificate for a TAX DEED to be issued thereon. The Certificate number and year of issuance, the description of the property, and the names in which it was assessed are as follows:  
 CERTIFICATE NUMBER: 2019-12190  
 YEAR OF ISSUANCE: 2019  
 DESCRIPTION OF PROPERTY: TYMBER SKAN ON THE LAKE SECTION 3 CONDO CB 2/51 UNIT B BLDG 29  
 PARCEL ID # 09-23-29-9403-29-002  
 Name in which assessed: KUMBALATARA A SIRIPALA  
 ALL of said property being in the County of Orange, State of Florida. Unless such certificate shall be redeemed according to law, the property described in such certificate will be sold to the highest bidder online at www.orange.realtaxdeed.com scheduled to begin at 10:00 a.m. ET, Sep 30, 2021.  
 Dated: Aug 12, 2021  
 Phil Diamond  
 County Comptroller  
 Orange County, Florida  
 By: R Kane  
 Deputy Comptroller  
 August 19, 26; September 2, 9, 2021  
 21-02762W

**FOURTH INSERTION**  
**NOTICE OF APPLICATION FOR TAX DEED**  
 NOTICE IS HEREBY GIVEN that THORNTON MELLON LLC the holder of the following certificate has filed said certificate for a TAX DEED to be issued thereon. The Certificate number and year of issuance, the description of the property, and the names in which it was assessed are as follows:  
 CERTIFICATE NUMBER: 2019-14731  
 YEAR OF ISSUANCE: 2019  
 DESCRIPTION OF PROPERTY: DOMMERICH HILLS FOURTH ADDITION 1/2 LOT 2 & W 5 FT LOT 3 BLK F  
 PARCEL ID # 29-21-30-9572-06-020  
 Name in which assessed: EDGAR REID COBB TR  
 ALL of said property being in the County of Orange, State of Florida. Unless such certificate shall be redeemed according to law, the property described in such certificate will be sold to the highest bidder online at www.orange.realtaxdeed.com scheduled to begin at 10:00 a.m. ET, Sep 30, 2021.  
 Dated: Aug 12, 2021  
 Phil Diamond  
 County Comptroller  
 Orange County, Florida  
 By: R Kane  
 Deputy Comptroller  
 August 19, 26; September 2, 9, 2021  
 21-02768W

**FOURTH INSERTION**  
**NOTICE OF APPLICATION FOR TAX DEED**  
 NOTICE IS HEREBY GIVEN that CRESCENDO INVESTMENTS LLC the holder of the following certificate has filed said certificate for a TAX DEED to be issued thereon. The Certificate number and year of issuance, the description of the property, and the names in which it was assessed are as follows:  
 CERTIFICATE NUMBER: 2019-19302  
 YEAR OF ISSUANCE: 2019  
 DESCRIPTION OF PROPERTY: LA VINA PHASE 2 57/66 LOT 232  
 PARCEL ID # 06-24-31-4105-02-320  
 Name in which assessed: CHEN SHIH JUO, CHIA-HENG CHANG, CHIA-CHEN CHANG  
 ALL of said property being in the County of Orange, State of Florida. Unless such certificate shall be redeemed according to law, the property described in such certificate will be sold to the highest bidder online at www.orange.realtaxdeed.com scheduled to begin at 10:00 a.m. ET, Sep 30, 2021.  
 Dated: Aug 12, 2021  
 Phil Diamond  
 County Comptroller  
 Orange County, Florida  
 By: R Kane  
 Deputy Comptroller  
 August 19, 26; September 2, 9, 2021  
 21-02774W

**FOURTH INSERTION**  
**NOTICE OF APPLICATION FOR TAX DEED**  
 NOTICE IS HEREBY GIVEN that THORNTON MELLON LLC the holder of the following certificate has filed said certificate for a TAX DEED to be issued thereon. The Certificate number and year of issuance, the description of the property, and the names in which it was assessed are as follows:  
 CERTIFICATE NUMBER: 2019-12195  
 YEAR OF ISSUANCE: 2019  
 DESCRIPTION OF PROPERTY: TYMBER SKAN ON THE LAKE SECTION 3 CONDO CB 2/51 UNIT E BLDG 49  
 PARCEL ID # 09-23-29-9403-49-005  
 Name in which assessed: DA ARK LLC  
 ALL of said property being in the County of Orange, State of Florida. Unless such certificate shall be redeemed according to law, the property described in such certificate will be sold to the highest bidder online at www.orange.realtaxdeed.com scheduled to begin at 10:00 a.m. ET, Sep 30, 2021.  
 Dated: Aug 12, 2021  
 Phil Diamond  
 County Comptroller  
 Orange County, Florida  
 By: R Kane  
 Deputy Comptroller  
 August 19, 26; September 2, 9, 2021  
 21-02763W

**FOURTH INSERTION**  
**NOTICE OF APPLICATION FOR TAX DEED**  
 NOTICE IS HEREBY GIVEN that THORNTON MELLON LLC the holder of the following certificate has filed said certificate for a TAX DEED to be issued thereon. The Certificate number and year of issuance, the description of the property, and the names in which it was assessed are as follows:  
 CERTIFICATE NUMBER: 2019-15429  
 YEAR OF ISSUANCE: 2019  
 DESCRIPTION OF PROPERTY: GOLFSIDE VILLAS CONDO CB 7/44 BLDG H UNIT 814  
 PARCEL ID # 15-22-30-3058-08-814  
 Name in which assessed: JOSEPH MICHAEL CINQUEMANI  
 ALL of said property being in the County of Orange, State of Florida. Unless such certificate shall be redeemed according to law, the property described in such certificate will be sold to the highest bidder online at www.orange.realtaxdeed.com scheduled to begin at 10:00 a.m. ET, Sep 30, 2021.  
 Dated: Aug 12, 2021  
 Phil Diamond  
 County Comptroller  
 Orange County, Florida  
 By: R Kane  
 Deputy Comptroller  
 August 19, 26; September 2, 9, 2021  
 21-02769W

**FOURTH INSERTION**  
**NOTICE OF APPLICATION FOR TAX DEED**  
 NOTICE IS HEREBY GIVEN that THORNTON MELLON LLC the holder of the following certificate has filed said certificate for a TAX DEED to be issued thereon. The Certificate number and year of issuance, the description of the property, and the names in which it was assessed are as follows:  
 CERTIFICATE NUMBER: 2019-20299  
 YEAR OF ISSUANCE: 2019  
 DESCRIPTION OF PROPERTY: (NOTE: HOMESTEAD PORTION OF THE FOLLOWING DESCRIBED PROPERTY) BEG N LINE OF SEC 34-22-32 AT W LINE ST RD 13 TH S 18 DEG E 316.12 FT W 660 FT N 300 FT TO N LINE OF SEC E 560.34 FT TO POB SEE 6837/2040  
 PARCEL ID # 34-22-32-0000-00-015  
 Name in which assessed: SARAH E DIETRICH  
 ALL of said property being in the County of Orange, State of Florida. Unless such certificate shall be redeemed according to law, the property described in such certificate will be sold to the highest bidder online at www.orange.realtaxdeed.com scheduled to begin at 10:00 a.m. ET, Sep 30, 2021.  
 Dated: Aug 12, 2021  
 Phil Diamond  
 County Comptroller  
 Orange County, Florida  
 By: R Kane  
 Deputy Comptroller  
 August 19, 26; September 2, 9, 2021  
 21-02775W

**ORANGE COUNTY**

**WHEN PUBLIC NOTICES REACH THE PUBLIC, EVERYONE BENEFITS.**

Some officials want to move notices from newspapers to government-run websites, where they may not be easily found.



**2 OUT OF 3**  
U.S. adults read a newspaper in print or online during the week.

**?**  
Why try to fix something that isn't broken?



**NEWSMEDIA ALLIANCE**  
www.newsmediaalliance.org

**Keep Public Notices in Newspapers.**

SP13857

**WHEN PUBLIC NOTICES REACH THE PUBLIC, EVERYONE BENEFITS.**

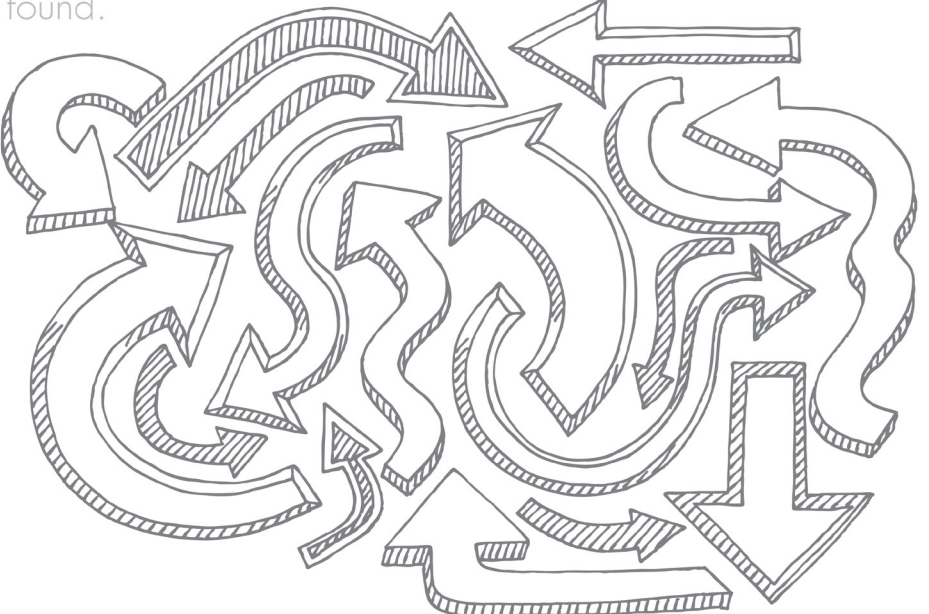
Some officials want to move notices from newspapers to government-run websites, where they may not be easily found.

**2 OUT OF 3**  
U.S. adults read a newspaper in print or online during the week.

**?**  
Why try to fix something that isn't broken?

**Keep Public Notices in Newspapers.**

**NEWSMEDIA ALLIANCE**  
www.newsmediaalliance.org

SP13858

**WHEN PUBLIC NOTICES REACH THE PUBLIC, EVERYONE BENEFITS.**

Some officials want to move notices from newspapers to government-run websites, where they may not be easily found.

**This is like putting the fox in charge of the hen house.**

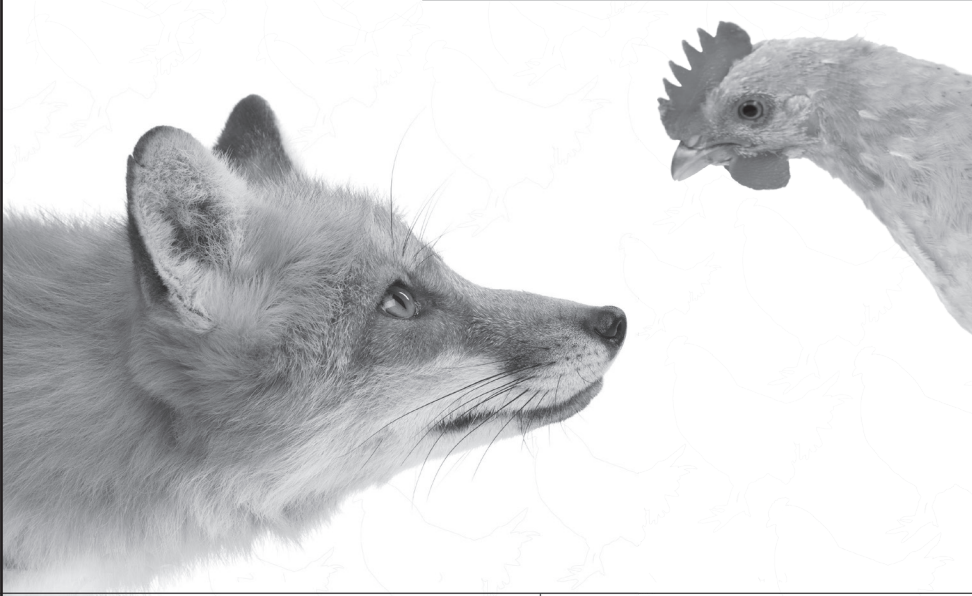

**Keep Public Notices in Newspapers**

**NEWSMEDIA ALLIANCE**  
www.newsmediaalliance.org

SP13859



There's a public hearing to decide if **your property taxes are going up 50%.**

*Wouldn't you want to know?*

**Did you know?**  
Local governments advertise notices of public hearings for proposed budgets and taxes in newspapers.

**Be Informed!**  
Read the public notices in this newspaper and at FloridaPublicNotices.com to know what's going on in your community.

**PUBLIC NOTICE DAY** JAN 28 2020



FloridaPublicNotices.com

SP13858

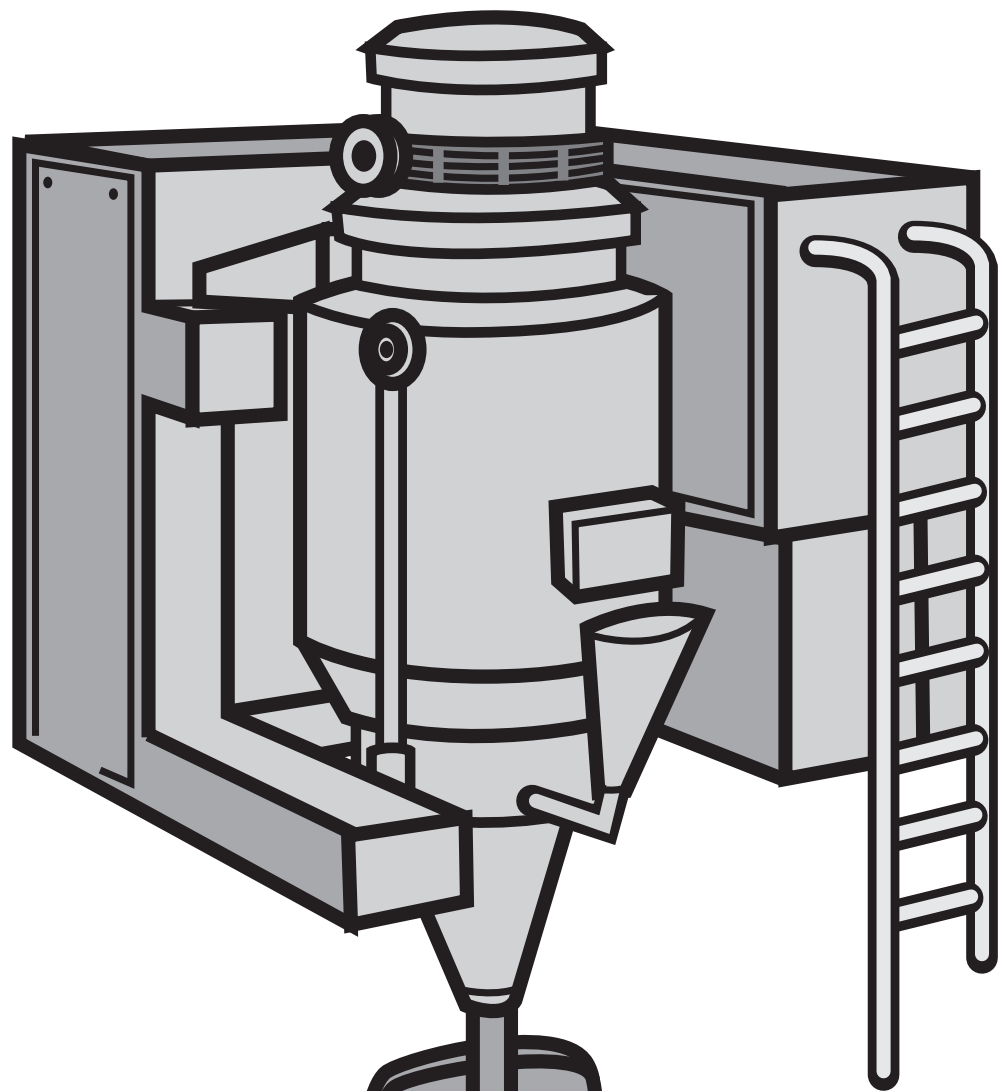

A special printing of  
a classic story illustrating  
the importance of  
protecting capitalism.

# TOM SMITH AND HIS INCREDIBLE BREAD MACHINE

By **R.W. Grant**

Illustrations by Austin McKinley

This is the legend of a man whose name  
Was a household word: a man whose fame  
Burst on the world like an atom bomb.  
Smith was his last name; first name: Tom.

The argument goes on today.  
"He was a villain," some will say.  
"No! A hero!" others declare.  
Or was he both? Well, I despair;  
The fight will last 'til kingdom come;  
Was Smith a hero? Or was Smith a bum?  
So, listen to the story and it's up to you  
To decide for yourself as to which is true!

Now, Smith, an inventor, had specialized  
In toys. So people were surprised  
When they found that he instead  
Of making toys, was baking bread!  
The news was flashed by CBS  
Of his incredible success.  
Then NBC jumped in in force,  
Followed by the Times, of course.  
The reason for their rapt attention,  
The nature of his new invention,  
The way to make bread he'd conceived  
Cost less than people could believe!  
And not just make it! This device  
Could in addition wrap and slice!  
The price per loaf, one loaf or many:  
The miniscule sum of under one penny!

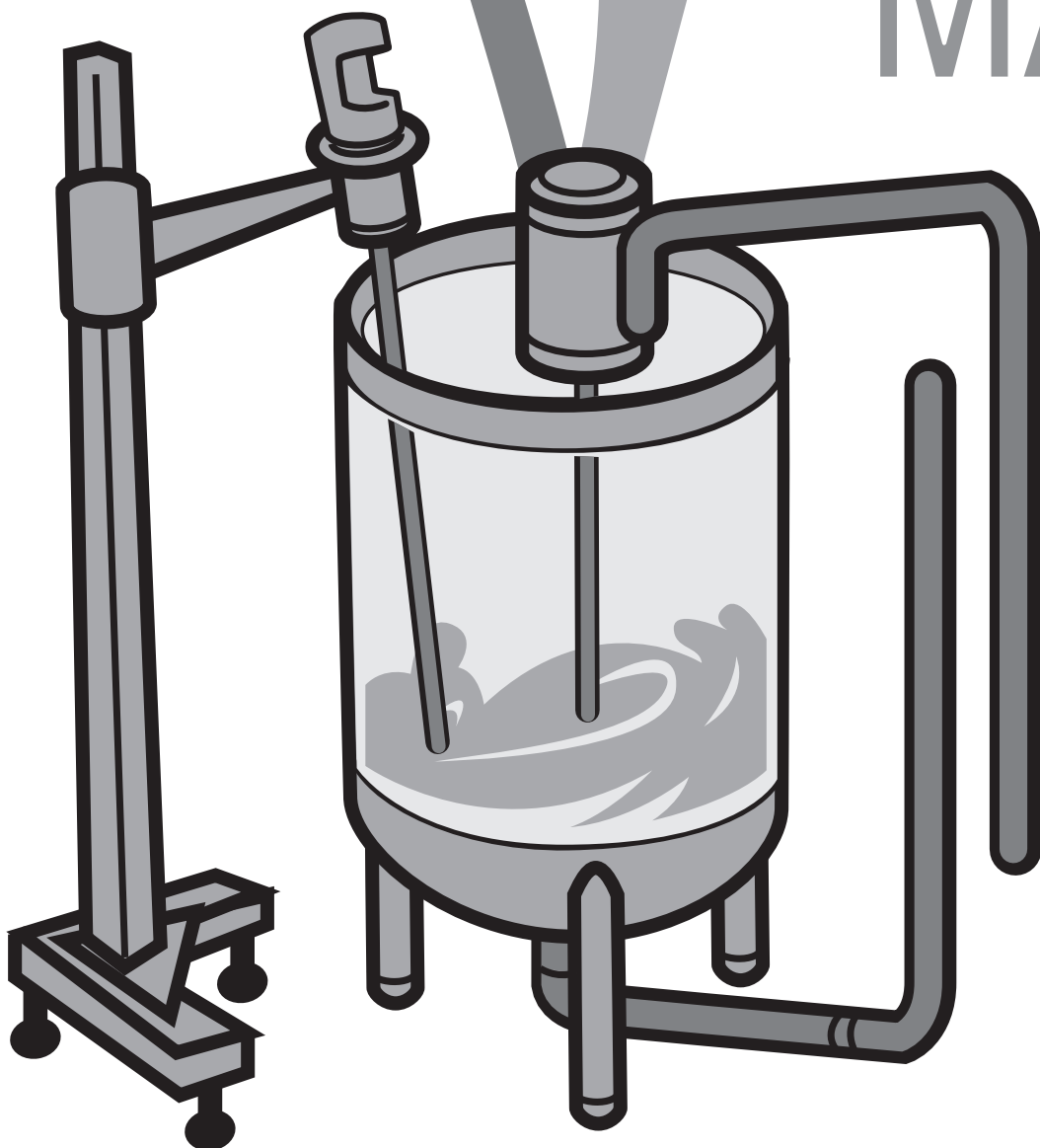

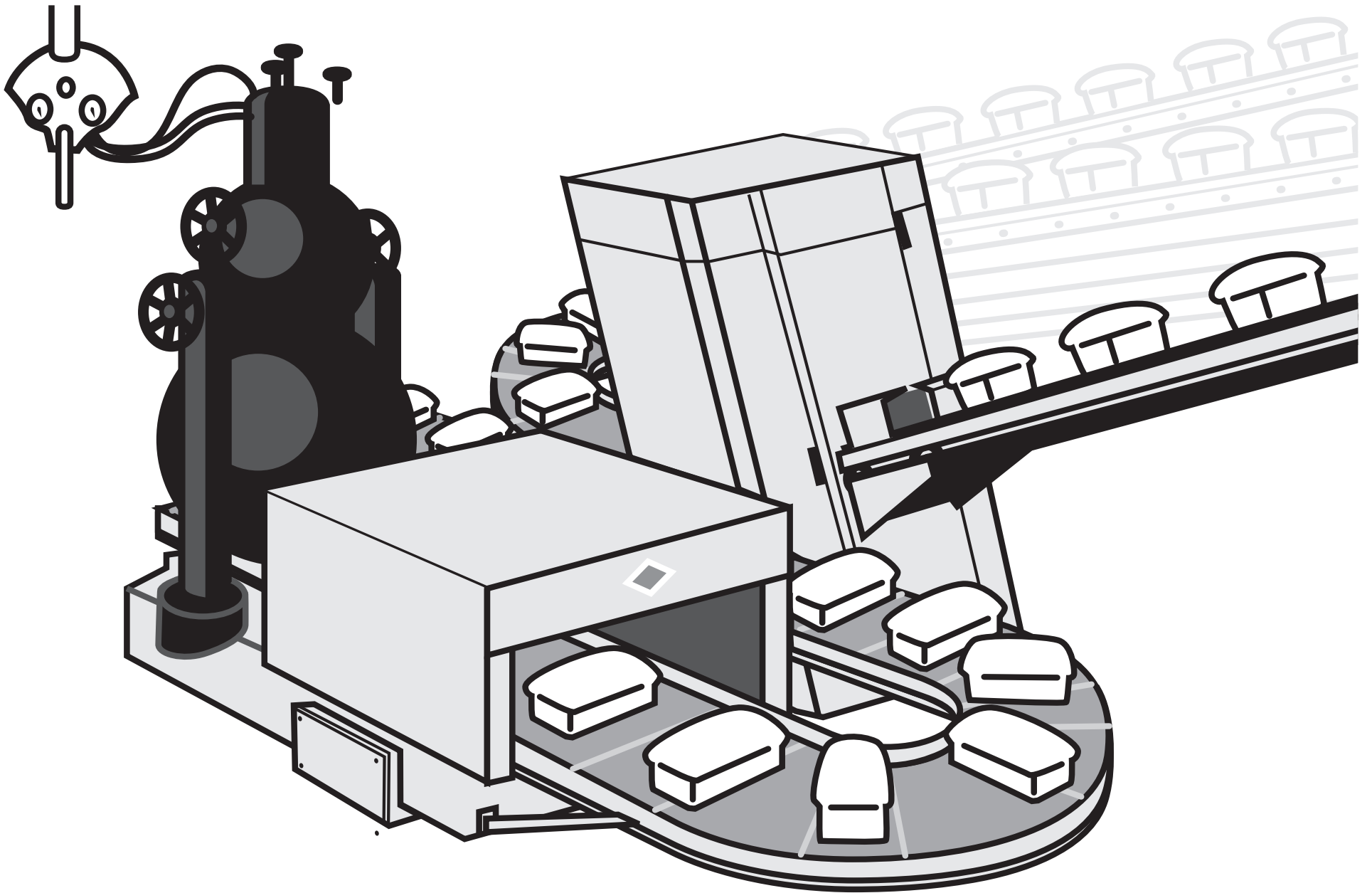
ORANGE  
COUNTY

Can you imagine what this meant?  
Can you comprehend the consequent?  
The first time yet the world well fed!  
And all because of Tom Smith's bread!

Not the last to see the repercussions  
Were the Red Chinese, and, of course, the  
Russians,  
For Capitalist bread in such array

Threw the whole red block into black dis-  
may!  
Nonetheless, the world soon found  
That bread was plentiful the world  
around.  
Thanks to Smith and all that bread,  
A grateful world was at last well fed!

But isn't it a wondrous thing  
How quickly fame is flown?  
Smith, the hero of today  
Tomorrow, scarcely known!  
Yes, the fickle years passed by.  
Smith was a billionaire.

But Smith himself was now forgot,  
Though bread was everywhere.  
People, asked from where it came,  
Would very seldom know.

They would simply eat and ask,  
'Was not it always so?'

However, Smith cared not a bit,  
For millions ate his bread,  
And "Everything is fine," thought he.  
"I'm rich and they are fed!"

Everything was fine, he thought?  
He reckoned not with fate.  
Note the sequence of events  
Starting on the date  
On which inflation took its toll,  
And to a slight extent,  
The price on every loaf increased:  
It went to one full cent!

A sharp reaction quickly came.  
People were concerned.  
White House aide expressed dismay.  
Then the nation learned  
That Russia lodged a sharp protest.  
India did the same.  
"Exploitation of the Poor!"  
Yet, who was there to blame?

And though the clamor ebbed and flowed,  
All that Tom would say  
Was that it was but foolish talk.  
Which soon would die away.  
And it appeared that he was right.  
Though on and on it ran,  
The argument went 'round and 'round  
But stopped where it began.

There it stopped, and people cried,  
"For heaven's sake, we can't decide!  
It's relative! Beyond dispute,  
There's no such thing as 'absolute'!  
And though we try with all our might,  
Since nothing's ever black or white,  
All that we can finally say is  
'Everything one shade of grey is!'  
So people cried out, "Give us light!  
We can't tell what's wrong from right!"

To comprehend confusion,  
We seek wisdom at its source.  
To whom, then did the people turn?  
The Intellectuals, of course!

And what could be a better time  
For them to take the lead,  
Than at their International Conference  
On Inhumanity and Greed.  
For at this weighty conference,  
Once each year we face  
The moral conscience of the world—  
Concentrated in one place.

At that mighty conference were  
A thousand, more or less,  
Of intellectuals and bureaucrats,  
And those who write the press.  
And from Yale and Harvard  
The professors; all aware  
The fate of Smith would now be known.  
Excitement filled the air!

"The time has come," the chairman said  
"To speak of many things:  
Of duty, bread and selfishness,  
And the evil that it brings.  
For, speaking thus we can amend  
That irony of fate  
That gives to unenlightened minds  
The power to create.



ORANGE COUNTY

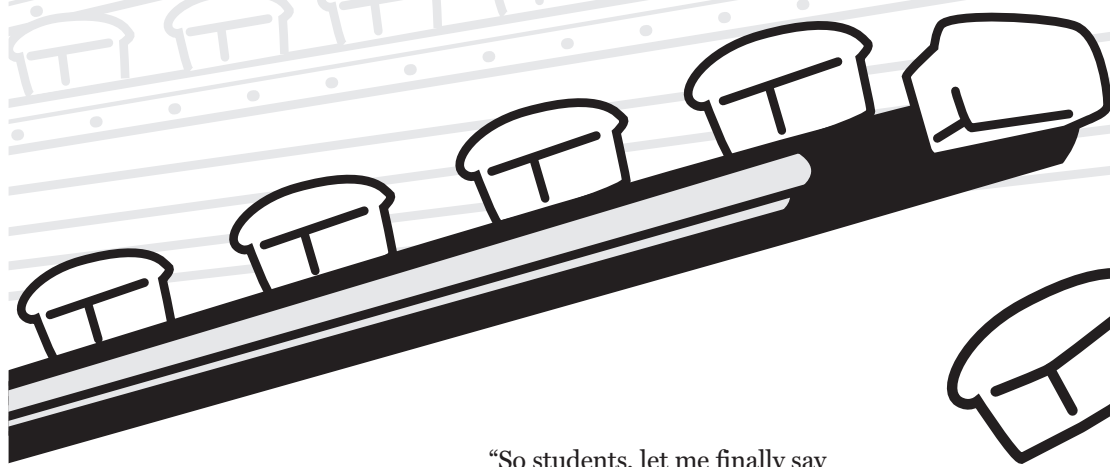

"Since reason tells us that it can't,  
Therefore let us start  
Not by thinking with the mind,  
But only with the heart!  
Since we believe in people, then,"  
At last the chairman said,  
'We must meet our obligation  
To see that they are fed!"

And so it went, one by one,  
Denouncing private greed;  
Denouncing those who'd profit thus  
From other people's need!

Then, suddenly each breath was held,  
For there was none more wise  
Than the nation's foremost Pundit  
Who now rose to summarize:

"My friends," he said, (they all  
exhaled)  
'We see in these events  
The flouting of the Higher Law—  
And its consequence.  
We must again remind ourselves  
Just why mankind is cursed:  
Because we fail to realize  
Society comes first!

"Smith placed himself above the  
group  
To profit from his brothers.  
He failed to see the Greater Good,  
Is Service, friends, to Others!"

With boldness and with vision,  
then,  
They ratified the motion  
To dedicate to all mankind  
Smith's bread-and their devotion!

The conference finally ended.  
It had been a huge success.  
The intellectuals had spoken.  
Now others did the rest.

The professors joined in all the  
fuss,  
And one was heard to lecture thus:  
(For clarity, he spoke in terms  
Of Mother Nature, birds and worms):

"That early birds should get the worm  
Is clearly quite unfair.  
Wouldn't it much nicer be  
If all of them would share?  
But selfishness and private greed

Seem part of nature's plan,  
Which Mother Nature has decreed  
For bird. But also Man?  
The system which I question now,  
As you are well aware,  
(I'm sure you've heard the term  
before  
Is Business, Laissez-Faire!

"So students, let me finally say  
That we must find a nobler way.  
So, let us fix the race that all  
May finish side-by-side;  
The playing field forever flat,  
The score forever tied.  
To achieve this end, of course,  
We turn to government-and force.  
So, if we have to bring Smith do  
As indeed we should,  
I'm sure you will agree with me,  
It's for the Greater Good!"

Comments in the nation's press  
Now scorned Smith and his plunder:  
'What right had he to get so rich  
On other people's hunger?"  
A prize cartoon depicted Smith  
With fat and drooping jowls  
Snatching bread from hungry babes,  
Indifferent to their howls.

One night, a TV star cried out,  
"Forgive me if I stumble,  
But I don't think, I kid you not,  
That Smith is very humble!"  
Growing bolder, he leaped up,

(Silencing the cheers)  
"Humility!" he cried to all—  
And then collapsed in tears!

The clamor rises all about;  
Now hear the politician shout:  
'What's Smith done, so rich to be?  
Why should Smith have more than thee?  
So, down with Smith and all his greed;  
I'll protect your right to need!"

Then Tom found to his dismay  
That certain businessmen would say,  
"The people now should realize  
It's time to cut Smith down to size,  
For he's betrayed his public trust  
(And taken all that bread from us!)"

Well, since the Public does come first,  
It could not be denied  
That in matters such as this,  
The public must decide.  
So, SEC became concerned,  
And told the press what it had learned:  
"It's obvious that he's guilty  
—Of what we're not aware—  
Though actually and factually  
We're sure there's something there!"

And Antitrust now took a hand.  
Of course it was appalled  
At what it found was going on.  
The "bread trust" it was called.

"Smith has too much crust,"  
they said. "A deplorable condition  
That Robber Barons profit thus  
From cutthroat competition!"

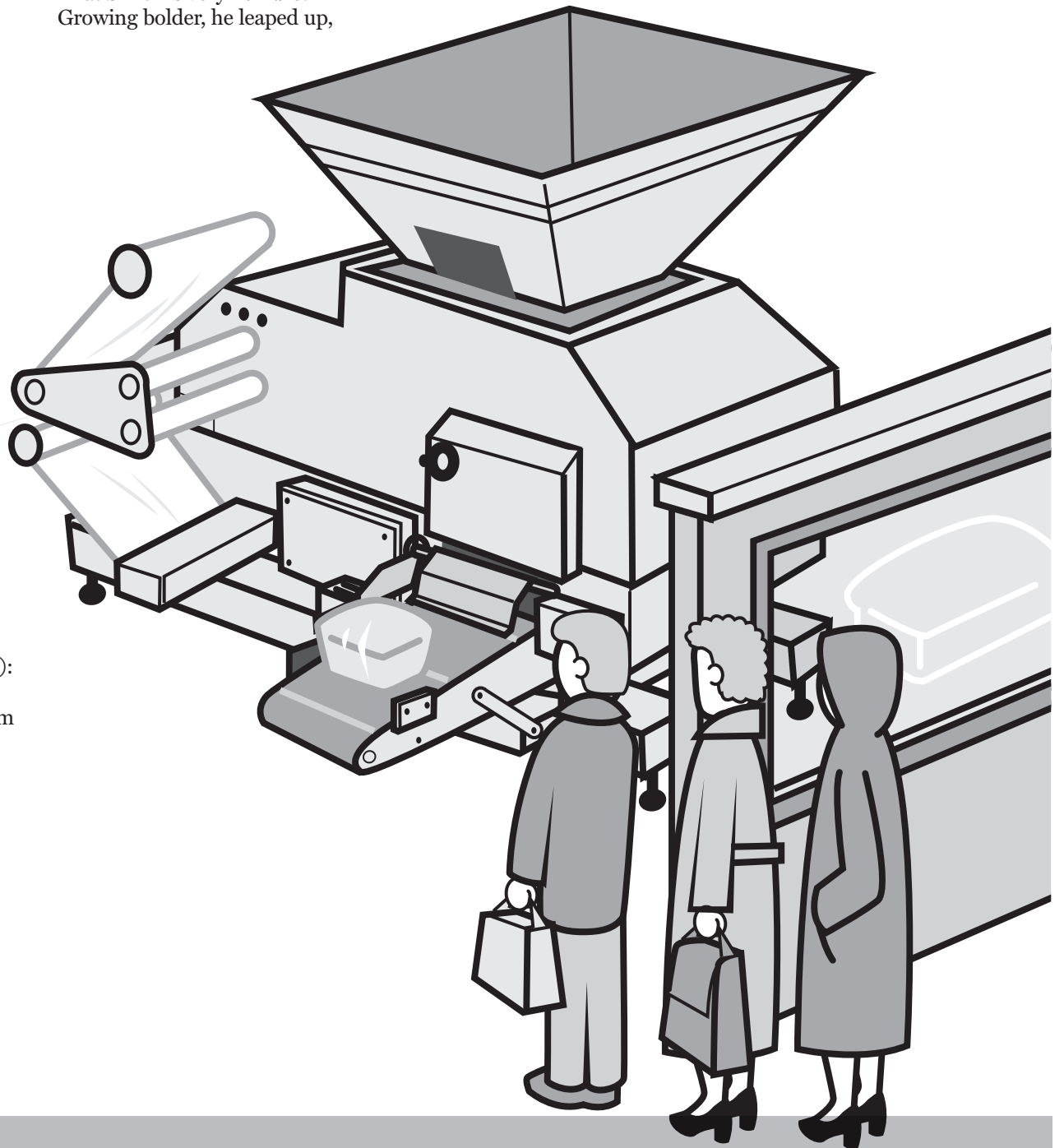



## ORANGE COUNTY

WELL!

This was getting serious!  
So Smith felt that he must  
Have a friendly interview  
With SEC and "Trust."  
So, hat in hand, he went to them.  
They'd surely been misled;  
No rule of law had he defied.  
But then their lawyer said:

"The rule of law, in complex times,  
Has proved itself deficient.  
We much prefer the rule of men.  
It's vastly more efficient.

"So, nutshell-wise, the way it is,  
The law is what we say it is!

"So, let me state the present rules,"  
The lawyer then went on,  
"These very simple guidelines  
You can rely upon:  
You're gouging on your prices  
If you charge more than the rest.  
But it's unfair competition  
If you think you can charge less!  
"A second point that we would make,  
To help avoid confusion:  
Don't try to charge the same amount,  
For that would be collusion!"

"You must compete—but not too much.  
For if you do, you see,  
Then the market would be yours—  
And that's monopoly!  
Oh, don't dare monopolize!  
We'd raise an awful fuss,  
For that's the greatest crime of all!  
(Unless it's done by us!)"

"I think I understand," said Tom.  
"And yet, before I go,  
How does one get a job like yours?  
I'd really like to know!"

The lawyer rose then with a smile;  
"I'm glad you asked," said he.  
"I'll tell you how I got my start  
And how it came to be."

(His secretaries gathered 'round  
As their boss did thus expound.)

*"When I was a lad going off to school,  
I was always guided by this golden rule:  
Let others take the lead in things, for  
heaven's sake,  
So if things go wrong—why, then it's their  
mistake!"  
(So if things go wrong—why, then it's their  
mistake!)*

*"Following this precept it came to pass  
I became the president of my senior class.  
Then on to college where my profs extolled  
The very same theory from the very same  
mold!"  
(The very same theory from the very same  
mold!)*

*"Let others take the chances, and I would  
go along.  
Then I would let them know where they all  
went wrong!  
So successful was my system that then  
indeed,  
I was voted most likely in my class to suc-  
ceed!"*

*(He was voted most likely in his class to  
succeed!)*

*"Then out into the world I went, along  
with all the rest,  
Where I put my golden rule to the ulti-  
mate test.  
I avoided all of commerce at whatever the  
cost—  
And because I never ventured, then I also  
never lost!"  
(And because he never ventured, then he  
also never lost!)*

*"With this unblemished record then, I  
quickly caught the eye  
Of some influential people 'mongst the  
powers on high.*

*And so these many years among the  
mighty I have sat,  
Having found my niche as a bureaucrat!"  
(Having found his niche as a bureaucrat)*

*"To be a merchant prince has never been  
my goal,  
For I'm qualified to play a more impor-  
tant role:  
Since I've never failed in business, this of  
course assures  
That I'm qualified beyond dispute to now  
run yours!"  
(That he's qualified beyond dispute to now  
run yours!)*

"Thanks; that clears it up," said Tom.

The lawyer said, "I'm glad!  
We try to serve the public good.  
We're really not so bad!"

"Now, in disposing of this case,  
If you wish to know just how,  
Go up to the seventh floor;  
We're finalizing now!"

So, Tom went to the conference room  
Up on the seventh floor.  
He raised his hand, about to knock,  
He raised it—but no more—  
For what he overheard within  
Kept him outside the door!  
A sentence here, a sentence there—  
Every other word—  
He couldn't make it out (he hoped),  
For this is what he heard:

"Mumble, mumble, let's not fumble!  
Mumble, mumble, what's the charge?  
Grumble, grumble, he's not humble?  
Private greed? Or good of all?"

"Public Interest, Rah! Rah! Rah!  
Business, Business, Bah! Bah! Bah!"

"Say, now this now we confess  
That now this now is a mess!  
Well now, what now do we guess?  
Discharge? Which charge would be best?"

"How 'bout 'Greed and Selfishness'?  
Oh, wouldn't that be fun?  
It's vague enough to trip him up  
No matter what he's done!"

"We don't produce or build a thing!  
But before we're through,  
We allow that now we'll show Smith how  
We handle those who do!"

"We serve the public interest;  
We make up our own laws;  
Oh, golly gee, how selflessly  
We serve the public cause!"

"For we're the ones who make the rules  
At "Trust and SEC,  
So bye and bye we'll get that guy;  
Now, what charge will it be?"

"Price too high? Or price too low?  
Now, which charge will we make?  
Well, we're not loath to charging both  
When public good's at stake!"

"But can we go one better?  
How 'bout monopoly?  
No muss, no fuss, oh clever us!  
Right-O! Let's charge all three!"

"But why stop here? We have one more!  
Insider Trading! Number four!  
We've not troubled to define  
This crime in any way so,  
This allows the courts to find  
Him guilty 'cause we say so!"

So, that was the indictment.  
Smith's trial soon began.  
It was a cause célèbre  
Which was followed' cross the land.  
In his defense Tom only said,  
"I'm rich, but all of you are fed!  
Is that bargain so unjust  
That I should now be punished thus?"

Tom fought it hard all the way.  
But it didn't help him win.  
The jury took but half an hour  
To bring this verdict in:

"Guilty! Guilty! We agree!  
He's guilty of this plunder!  
He had no right to get so rich  
On other people's hunger!"

"Five years in jail!" the judge then said.  
"You're lucky it's not worse!  
Robber Barons must be taught  
Society Comes First!  
As flies to wanton boys," he leered,  
"Are we to men like these!  
They exploit us for their sport!  
Exploit us as they please!"

The sentence seemed a bit severe,  
But mercy was extended.  
In deference to his mother's pleas,  
One year was suspended.  
And what about the Bread Machine?  
Tom Smith's little friend?  
Broken up and sold for scrap.  
Some win. Some lose. The end.

### EPILOGUE

Now, bread is baked by government.  
And as might be expected,  
Everything is well controlled—  
The public well protected.

True, loaves cost ten dollars each.  
But our leaders do their best.  
The selling price is half a cent.  
Taxes pay the rest!



# Why Public Notice Should Remain in Newspapers

Along with open meeting and freedom of information laws, public notice is an essential element of the

**three-legged stool of government transparency**

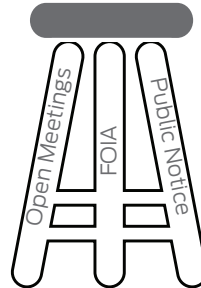

This is not about “newspapers vs the internet”.

**It’s newspapers *and* newspaper websites vs government websites**

and newspaper websites have a much larger audience. Moving notice from newspapers to government websites would **reduce the presence of public notices on the internet**



Requiring independent, third-party newspapers to ensure that public notices run in accordance with the law helps

**prevent government officials from hiding information**

they would prefer the public not to see

Since the first U.S. Congress, public officials have understood that newspapers are the best medium to notify the public about official matters because they contain the **essential elements of public notice:**



**Accessibility**



**Independence**



**Verifiability**



**Archivability**

**Publishing notices on the internet is neither cheap nor free**



Newspapers remain the primary vehicle for public notice in

**all 50 states**



## Types Of Public Notices

### Citizen Participation Notices

- Government Meetings and Hearings
- Land and Water Use
- Meeting Minutes or Summaries
- Creation of Special Tax Districts
- Agency Proposals
- School District Reports
- Proposed Budgets and Tax Rates
- Zoning, Annexation and Land Use Changes

### Commercial Notices

- Unclaimed Property, Banks or Governments
- Delinquent Tax Lists, Tax Deed Sales
- Government Property Sales
- Permit and License Applications

### Court Notices

- Mortgage Foreclosures
- Name Changes
- Probate Rulings
- Divorces and Adoptions
- Orders to Appear in Court

## Stay Informed, It’s Your Right to Know.

For legal notice listings go to: [Legals.BusinessObserverFL.com](https://Legals.BusinessObserverFL.com)

To publish your legal notice call: 941-906-9386 or [Legal@BusinessObserverFL.com](mailto:Legal@BusinessObserverFL.com)

**ORANGE COUNTY**



**Newsprint is inherently superior to the internet for public notice** because reading a newspaper is a serendipitous process.

We find things in newspapers we weren't expecting to see. On the internet, we search for specific information and ignore everything else.



**Citizens continue to learn about vital civic matters from newspaper notices.**

Documented examples of people taking action and alerting their community after reading a newspaper notice are reported on a regular basis.

**Verifying publication is difficult-to-impossible on the web.**

That's why the courts subject digital evidence to far greater scrutiny than evidence published in newspapers

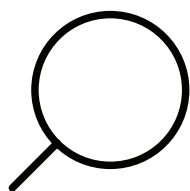

**Significant numbers of people in rural areas still lack high-speed internet access.**

Those who are older than 65 or who have lower incomes or lack high-school diplomas are also cut off from the internet in far higher numbers than the average.

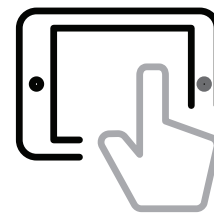

**Moreover, the real digital divide for public notice is growing**

due to the massive migration to smartphones and other small-screen digital devices

**Governments aren't very good at publishing information on the internet.**

Unlike newspaper publishers, public officials aren't compelled by the free market to operate effective websites.



**Types Of Public Notices**

**Citizen Participation Notices**

- Government Meetings and Hearings
- Land and Water Use
- Meeting Minutes or Summaries
- Creation of Special Tax Districts
- Agency Proposals
- School District Reports
- Proposed Budgets and Tax Rates
- Zoning, Annexation and Land Use Changes

**Commercial Notices**

- Unclaimed Property, Banks or Governments
- Delinquent Tax Lists, Tax Deed Sales
- Government Property Sales
- Permit and License Applications

**Court Notices**

- Mortgage Foreclosures
- Name Changes
- Probate Rulings
- Divorces and Adoptions
- Orders to Appear in Court

**Stay Informed, It's Your Right to Know.**

For legal notice listings go to: [Legals.BusinessObserverFL.com](http://Legals.BusinessObserverFL.com)  
 To publish your legal notice call: 941-906-9386 or [Legal@BusinessObserverFL.com](mailto:Legal@BusinessObserverFL.com)

# ESSENTIAL ELEMENTS OF A PUBLIC NOTICE

Federal and state public notice statutes generally establish four fundamental criteria for a public notice.

Each of these elements are critical aspects of the checks and balances that public notice was designed to foster.



## 1. Accessible

Every citizen in the jurisdiction affected by the notice must have a realistic opportunity to read it



## 2. Archivable

Notices must be capable of being archived in a secure and publicly available format for the use of the judicial system, researchers and historians



## 3. Independent

Notices must be published by organizations independent of the government body or corporation whose plans or actions are the subject of the notice



## 4. Verifiable

There must be a way to verify that each notice was an original, unaltered notice and actually published in accordance with the law



### Types Of Public Notices

#### Citizen Participation Notices

- Government Meetings and Hearings
- Land and Water Use
- Meeting Minutes or Summaries
- Creation of Special Tax Districts
- Agency Proposals
- School District Reports
- Proposed Budgets and Tax Rates
- Zoning, Annexation and Land Use Changes

#### Commercial Notices

- Unclaimed Property, Banks or Governments
- Delinquent Tax Lists, Tax Deed Sales
- Government Property Sales
- Permit and License Applications

#### Court Notices

- Mortgage Foreclosures
- Name Changes
- Probate Rulings
- Divorces and Adoptions
- Orders to Appear in Court

### Stay Informed, It's Your Right to Know.

For legal notice listings go to: [Legals.BusinessObserverFL.com](https://legals.businessobserverfl.com)

To publish your legal notice call: 941-906-9386 or [Legal@BusinessObserverFL.com](mailto:Legal@BusinessObserverFL.com)