

## COLLIER COUNTY LEGAL NOTICES

### FIRST INSERTION

NOTICE TO CREDITORS IN THE CIRCUIT COURT FOR COLLIER COUNTY, FLORIDA PROBATE DIVISION  
**File No: 11-2023-CP-002619-0001-XX**  
**IN RE: ESTATE OF EGBERT KRISPYN Deceased**

TO ALL PERSONS HAVING CLAIMS OR DEMANDS AGAINST THE ABOVE ESTATE:

The Administration of the estate of EGBERT KRISPYN File No. 2023-002619 is pending in the Circuit Court for Collier County, Florida, Probate Division, the address of which is 3315 Tamiami Trail East, Naples, FL 34112. The names and address of the personal representative and the personal representative's attorney are set forth below.

ALL INTERESTED PERSONS ARE NOTIFIED THAT:

All creditors of the decedent and other persons having claims or demands against decedent's estate on whom a copy of this notice is served within three months after the date of the first publication of this notice must file their claims with this Court WITHIN THE LATER OF THREE MONTHS AFTER THE DATE OF THE FIRST PUBLICATION OF THIS NOTICE OR THIRTY DAYS AFTER THE DATE OF SERVICE OF A COPY OF THIS NOTICE ON THEM.

All other creditors of the decedent and persons having claims or demands against the estate of the decedent must file their claims with this court WITHIN THREE MONTHS AFTER THE DATE OF THE FIRST PUBLICATION OF THIS NOTICE.

ALL CLAIMS AND DEMANDS NOT SO FILED WILL BE FOREVER BARRED.

Publication of this notice has begun on September 15, 2023.

**JEANETTE ATKINSON**  
**Personal Representative**  
 116 Trinidad Street  
 Naples, FL 34113

**RONALD S. WEBSTER**  
 Fla. Bar No. 570559  
 800 N. Collier Blvd.  
 Marco Island, FL 34145  
 (239) 394-8999  
 September 15, 22, 2023 23-01828C

### FIRST INSERTION

NOTICE TO CREDITORS IN THE CIRCUIT COURT FOR COLLIER COUNTY, FLORIDA PROBATE DIVISION  
**File No: 23-CP-2541**  
**IN RE: ESTATE OF Stanley Martin Rogalewicz, Deceased.**

The administration of the estate of Stanley Martin Rogalewicz, deceased, whose date of death was November 20, 2022, is pending in the Circuit Court for Collier County, Florida, Probate Division, the address of which is 3315 Tamiami Trail E. Ste. 102, Naples, Florida 34112. The names and addresses of the personal representative and the personal representative's attorney are set forth below.

All creditors of the decedent and other persons having claims or demands against decedent's estate, including unmaturred, contingent or unliquidated claims, on whom a copy of this notice is served must file their claims with this court WITHIN THE LATER OF 3 MONTHS AFTER THE DATE OF THE FIRST PUBLICATION OF THIS NOTICE OR 30 DAYS AFTER THE DATE OF SERVICE OF A COPY OF THIS NOTICE ON THEM.

All other creditors of the decedent and other persons having claims or demands against decedent's estate, including unmaturred, contingent or unliquidated claims, must file their claims with this court WITHIN 3 MONTHS AFTER THE DATE OF THE FIRST PUBLICATION OF THIS NOTICE.

ALL CLAIMS NOT SO FILED WILL BE FOREVER BARRED.

The date of first publication of this Notice is September 15, 2023.

**Personal Representative:**  
 /s/ **Wanda Rivera**  
 484 Anita St.  
 Des Plaines, Illinois 60016

Attorney for Personal Representative:  
 /s/Vito M. Roppo, Esq.  
 Fla. Bar No. 0112153  
 Colosseum Counsel, PLLC  
 3811 Airport Pulling Road  
 Suite 203  
 Naples, FL 34105  
 Telephone: (239) 631-8160  
 Vito@FightForMe.com  
 September 15, 22, 2023 23-01844C

### FIRST INSERTION

NOTICE TO CREDITORS IN THE CIRCUIT COURT FOR COLLIER COUNTY, FLORIDA PROBATE DIVISION  
**File No: 23-CP-1729**  
**IN RE: ESTATE OF Jimmy L. Pepper, Deceased.**

The administration of the estate of Jimmy L. Pepper, deceased, whose date of death was May 8, 2023, is pending in the Circuit Court for Collier County, Florida, Probate Division, the address of which is 3315 Tamiami Trail E. Ste. 102, Naples, Florida 34112. The names and addresses of the personal representative and the personal representative's attorney are set forth below.

All creditors of the decedent and other persons having claims or demands against decedent's estate, including unmaturred, contingent or unliquidated claims, on whom a copy of this notice is served must file their claims with this court WITHIN THE LATER OF 3 MONTHS AFTER THE DATE OF THE FIRST PUBLICATION OF THIS NOTICE OR 30 DAYS AFTER THE DATE OF SERVICE OF A COPY OF THIS NOTICE ON THEM.

All other creditors of the decedent and other persons having claims or demands against decedent's estate, including unmaturred, contingent or unliquidated claims, must file their claims with this court WITHIN 3 MONTHS AFTER THE DATE OF THE FIRST PUBLICATION OF THIS NOTICE.

ALL CLAIMS NOT SO FILED WILL BE FOREVER BARRED.

The date of first publication of this Notice is September 15, 2023.

**Personal Representative:**  
 /s/ **Jimmy F. Pepper**  
 815 11th St NW  
 Naples, Florida 34120

Attorney for Personal Representative:  
 /s/Vito M. Roppo, Esq.  
 Fla. Bar No. 0112153  
 Colosseum Counsel, PLLC  
 3811 Airport Pulling Road  
 Suite 203  
 Naples, FL 34105  
 Telephone: (239) 631-8160  
 Vito@FightForMe.com  
 September 15, 22, 2023 23-01843C

### FIRST INSERTION

NOTICE TO CREDITORS IN THE CIRCUIT COURT OF THE TWENTIETH JUDICIAL CIRCUIT IN AND FOR COLLIER COUNTY, FLORIDA PROBATE DIVISION  
**File No. 11-2023-CP-001872-0001-XX**  
**IN RE: ESTATE OF MICHAEL J. PISARCZYK DECEASED**

The administration of the estate of Michael J. Pisarczyk, deceased, whose date of death was June 15, 2022, is pending in the Circuit Court for Collier County, Florida, Probate Division; File Number 2023-CP-001872; the address of which is 3315 Tamiami Trail East, Naples, FL 34112. The names and addresses of the personal representative and the personal representative's attorney are set forth below.

All creditors of the decedent and other persons, who have claims or demands against decedent's estate, including unmaturred, contingent or unliquidated claims, and who have been served a copy of this notice, must file their claims with this court WITHIN THE LATER OF THREE (3) MONTHS AFTER THE DATE OF THE FIRST PUBLICATION OF THIS NOTICE OR THIRTY (30) DAYS AFTER THE DATE OF SERVICE OF A COPY OF THIS NOTICE ON THEM.

ALL CLAIMS NOT SO FILED WILL BE FOREVER BARRED.

NOTWITHSTANDING THE TIME PERIODS SET FORTH ABOVE, ANY CLAIM FILED TWO (2) YEARS OR MORE AFTER THE DECEDENT'S DATE OF DEATH IS BARRED.

THE DATE OF FIRST PUBLICATION OF THIS NOTICE IS SEPTEMBER 15, 2023.

**Personal Representative:**  
**Teresa C. Pisarczyk**  
 6660 Beach Resort Dr. Apt 4  
 Naples, FL 34114

Attorney for Personal Representative:  
 Jamie B. Greusel, Esq.  
 Florida Bar No. 0709174  
 1104 North Collier Blvd.  
 Marco Island, FL 34145  
 239 394 8111  
 jamie@jamiagreusel.net  
 September 15, 22, 2023 23-01865C

### FIRST INSERTION

NOTICE TO CREDITORS IN THE CIRCUIT COURT FOR COLLIER COUNTY, FLORIDA PROBATE DIVISION  
**File No. 23CP2583**  
**IN RE: ESTATE OF JOEL DEAN ROGERS, Deceased.**

The administration of the estate of JOEL DEAN ROGERS, deceased, whose date of death was August 20, 2023, is pending in the Circuit Court for Collier County, Florida, Probate Division, the address of which is 3315 Tamiami Trl. E, Naples, FL 34112. The names and addresses of the personal representative and the personal representative's attorney are set forth below.

All creditors of the decedent and other persons having claims or demands against decedent's estate, on whom a copy of this notice is required to be served, must file their claims with this court ON OR BEFORE THE LATER OF 3 MONTHS AFTER THE TIME OF THE FIRST PUBLICATION OF THIS NOTICE OR 30 DAYS AFTER THE DATE OF SERVICE OF A COPY OF THIS NOTICE ON THEM.

All other creditors of the decedent and other persons having claims or demands against decedent's estate must file their claims with this court WITH-

IN 3 MONTHS AFTER THE DATE OF THE FIRST PUBLICATION OF THIS NOTICE.

ALL CLAIMS NOT FILED WITHIN THE TIME PERIODS SET FORTH IN FLORIDA STATUTES SECTION 733.702 WILL BE FOREVER BARRED.

NOTWITHSTANDING THE TIME PERIOD SET FORTH ABOVE, ANY CLAIM FILED TWO (2) YEARS OR MORE AFTER THE DECEDENT'S DATE OF DEATH IS BARRED.

The date of first publication of this notice is: September 15, 2023.

Signed on this 11th day of September, 2023.

/s/ **Melinda Sue Rogers**  
**MELINDA SUE ROGERS**  
**Personal Representative**

3711 29th Ave. SW  
 Naples, FL 34117

/s/ Thomas F. Hudgins, Esq.  
 Thomas F. Hudgins, Esq.  
 Attorney for Personal Representative  
 Florida Bar No. 970565  
 Thomas F. Hudgins, PLLC  
 2800 Davis Blvd., #203  
 Naples, FL 34104  
 Telephone: (239) 263-7660  
 Email: Ted@naplestax.com  
 Secondary Email:  
 service@naplestax.com  
 September 15, 22, 2023 23-01855C

### FIRST INSERTION

NOTICE TO CREDITORS IN THE CIRCUIT COURT FOR COLLIER COUNTY, FLORIDA PROBATE DIVISION  
**File No. 21-CP-2549**  
**Division Probate**  
**IN RE: ESTATE OF SCOTT L. KISH, Deceased.**

The administration of the estate of Scott L. Kish, deceased, whose date of death was June 13, 2021, is pending in the Circuit Court for Collier County, Florida, Probate Division, the address of which is 3315 Tamiami Trail E., Naples, FL 34112. The names and addresses of the personal representative and the personal representative's attorney are set forth below.

All creditors of the decedent and other persons having claims or demands against decedent's estate on whom a copy of this notice is required to be served must file their claims with this court ON OR BEFORE THE LATER OF 3 MONTHS AFTER THE TIME OF THE FIRST PUBLICATION OF THIS NOTICE OR 30 DAYS AFTER THE DATE OF SERVICE OF A COPY OF THIS NOTICE ON THEM.

All other creditors of the decedent and other persons having claims or demands against decedent's estate must

file their claims with this court WITHIN 3 MONTHS AFTER THE DATE OF THE FIRST PUBLICATION OF THIS NOTICE.

ALL CLAIMS NOT FILED WITHIN THE TIME PERIODS SET FORTH IN FLORIDA STATUTES SECTION 733.702 WILL BE FOREVER BARRED.

NOTWITHSTANDING THE TIME PERIOD SET FORTH ABOVE, ANY CLAIM FILED TWO (2) YEARS OR MORE AFTER THE DECEDENT'S DATE OF DEATH IS BARRED.

The date of first publication of this notice is September 15, 2023.

**Personal Representative:**  
**Scott L. Kish II**  
 7206 Wilton Drive  
 Naples, FL 34110

Attorneys for Personal Representative:  
 John S. Sarrett  
 Michael A. Gebeau  
 E-Mail Addresses:  
 jsarrett@sarrettprice.com  
 Florida Bar No.: 812811  
 MGebeau@sarrettprice.com  
 Florida Bar No.: 1025405  
 Sarrett Price, P.A.  
 999 Vanderbilt Beach Road  
 Naples, FL 34108  
 Telephone: 239-330-2359  
 September 15, 22, 2023 23-01838C

### FIRST INSERTION

NOTICE TO CREDITORS IN THE CIRCUIT COURT FOR COLLIER COUNTY, FLORIDA PROBATE DIVISION  
**File No. 23-CP-2510**  
**IN RE: ESTATE OF CHRISTINE K. TILLY, Deceased.**

The administration of the estate of CHRISTINE K. TILLY, deceased, whose date of death was November 18, 2022, is pending in the Circuit Court for Collier County, Florida, Probate Division, the address of which is 3315 Tamiami Trail East, Naples, FL 34112. The names and addresses of the personal representative and the personal representative's attorney are set forth below.

All creditors of the decedent and other persons having claims or demands against decedent's estate, on whom a copy of this notice is required to be served, must file their claims with this court ON OR BEFORE THE LATER OF 3 MONTHS AFTER THE TIME OF THE FIRST PUBLICATION OF THIS NOTICE OR 30 DAYS AFTER THE DATE OF SERVICE OF A COPY OF THIS NOTICE ON THEM.

All other creditors of the decedent and other persons having claims or demands against decedent's estate must file their claims with this court WITHIN 3 MONTHS AFTER THE DATE OF THE FIRST PUBLICATION OF THIS NOTICE.

ALL CLAIMS NOT FILED WITHIN THE TIME PERIODS SET FORTH IN FLORIDA STATUTES SECTION 733.702 WILL BE FOREVER BARRED.

NOTWITHSTANDING THE TIME PERIOD SET FORTH ABOVE, ANY CLAIM FILED TWO (2) YEARS OR MORE AFTER THE DECEDENT'S DATE OF DEATH IS BARRED.

The date of first publication of this notice is: September 15, 2023.

**JAMES R. NICI**  
**Personal Representative**  
 1865 Veterans Park Drive, Suite 203  
 Naples, FL 34109

**JAMES R. NICI, ESQ.**  
 Attorney for Personal Representative  
 Florida Bar No. 0000507  
 Nici Law Firm, P.L.  
 1865 Veterans Park Drive,  
 Suite 203  
 Naples, FL 34109  
 Telephone: (239) 449-6150  
 Email: jnici@nicilawfirm.com  
 September 15, 22, 2023 23-01842C

### FIRST INSERTION

NOTICE TO CREDITORS IN THE CIRCUIT COURT FOR COLLIER COUNTY, FLORIDA PROBATE DIVISION  
**File No. 11-2023-CP-002150-0001-XX**  
**IN RE: ESTATE OF LEO EAMMA, JR., Deceased.**

The administration of the estate of LEO EAMMA, JR., deceased, whose date of death was November 17, 2022, is pending in the Circuit Court for Collier County, Florida, Probate Division, the address of which is 3315 Tamiami Trail East, Naples, FL 34112. The names and addresses of the personal representative and the personal representative's attorney are set forth below.

All creditors of the decedent and other persons having claims or demands against decedent's estate on whom a copy of this notice is required to be served must file their claims with this court WITHIN THE LATER OF 3 MONTHS AFTER THE TIME OF THE FIRST PUBLICATION OF THIS NOTICE OR 30 DAYS AFTER THE DATE OF SERVICE OF A COPY OF THIS NOTICE ON THEM.

All other creditors of the decedent and other persons having claims or demands against decedent's estate must file their claims with this court WITHIN 3 MONTHS AFTER THE DATE OF THE FIRST PUBLICATION OF THIS NOTICE.

ALL CLAIMS NOT FILED WITHIN THE TIME PERIODS SET FORTH IN SECTION 733.702 OF THE FLORIDA PROBATE CODE WILL BE FOREVER BARRED.

NOTWITHSTANDING THE TIME PERIODS SET FORTH ABOVE, ANY CLAIM FILED TWO (2) YEARS OR MORE AFTER THE DECEDENT'S DATE OF DEATH IS BARRED.

The date of first publication of this notice is September 15, 2023.

**Personal Representative:**  
**Karen DiMeglio**  
**c/o Christopher A. Likens, Esq.**  
 1800 Second Street, Suite 971  
 Sarasota, FL 34236

Attorney for Personal Representative:  
 Christopher A. Likens  
 Florida Bar Number: 0981303  
 CHRISTOPHER A. LIKENS, P.A.  
 1800 Second Street, Suite 971  
 Sarasota, FL 34236  
 Telephone: (941) 365-7838  
 cservice@calikens.com  
 September 15, 22, 2023 23-01841C

### FIRST INSERTION

NOTICE TO CREDITORS IN THE CIRCUIT COURT FOR COLLIER COUNTY, FLORIDA PROBATE DIVISION  
**File No. 2023-CP-002497**  
**IN RE: ESTATE OF JOHN R. WHITING, Deceased.**

The administration of the estate of JOHN R. WHITING, deceased, whose date of death was July 6, 2023, is pending in the Circuit Court for Collier County, Florida, Probate Division, the address of which is 3315 Tamiami Trail East, Naples, FL 34112. The names and addresses of the personal representative and the personal representative's attorney are set forth below.

All creditors of the decedent and other persons having claims or demands against decedent's estate, on whom a copy of this notice is required to be served, must file their claims with this court ON OR BEFORE THE LATER OF 3 MONTHS AFTER THE TIME OF THE FIRST PUBLICATION OF THIS NOTICE OR 30 DAYS AFTER THE DATE OF SERVICE OF A COPY OF THIS NOTICE ON THEM.

All other creditors of the decedent and other persons having claims or demands against decedent's estate must file their claims with this court WITHIN 3 MONTHS AFTER THE DATE OF THE FIRST PUBLICATION OF THIS NOTICE.

ALL CLAIMS NOT FILED WITHIN THE TIME PERIODS SET FORTH IN FLORIDA STATUTES SECTION 733.702 WILL BE FOREVER BARRED.

NOTWITHSTANDING THE TIME PERIOD SET FORTH ABOVE, ANY CLAIM FILED TWO (2) YEARS OR MORE AFTER THE DECEDENT'S DATE OF DEATH IS BARRED.

The date of first publication of this notice is: September 15, 2023.

**KENNETH P. WHITING III**  
**Personal Representative**  
 169 Leory Street  
 Binghamton, NY 13905

Charles M. Kelly, Jr.  
 Attorney for Personal Representative  
 Florida Bar No. 364495  
 Kelly, Passidomo & Kelly, LLP  
 2390 Tamiami Trail North  
 Suite 204  
 Naples, Florida 34103  
 Telephone: 239-261-3453  
 Email: ckelly@flinttrust.com  
 Secondary Email:  
 groupservice@flinttrust.com  
 September 15, 22, 2023 23-01827C

### FIRST INSERTION

NOTICE TO CREDITORS IN THE CIRCUIT COURT FOR COLLIER COUNTY, FLORIDA PROBATE DIVISION  
**File No. 23-CP-2627**  
**IN RE: ESTATE OF PETER J. VICINANZO Deceased.**

The administration of the estate of Peter J. Vicinanza, deceased, whose date of death was June 29, 2023, is pending in the Circuit Court for Collier County, Florida, Probate Division, the address of which is 3315 Tamiami Trail East, Ste. 102, Naples, Florida 34112. The names and addresses of the personal representative and the personal representative's attorney are set forth below.

All creditors of the decedent and other persons having claims or demands against decedent's estate on whom a copy of this notice is required to be served must file their claims with this court ON OR BEFORE THE LATER OF 3 MONTHS AFTER THE TIME OF THE FIRST PUBLICATION OF THIS NOTICE OR 30 DAYS AFTER THE DATE OF SERVICE OF A COPY OF THIS NOTICE ON THEM.

All other creditors of the decedent and other persons having claims or demands against decedent's estate must file their claims with this court WITHIN 3 MONTHS AFTER THE DATE OF THE FIRST PUBLICATION OF THIS NOTICE.

ALL CLAIMS NOT FILED WITHIN THE TIME PERIODS SET FORTH IN FLORIDA STATUTES SECTION 733.702 WILL BE FOREVER BARRED.

NOTWITHSTANDING THE TIME PERIODS SET FORTH ABOVE, ANY CLAIM FILED TWO (2) YEARS OR MORE AFTER THE DECEDENT'S DATE OF DEATH IS BARRED.

The date of first publication of this notice is September 15, 2023.

**Personal Representative:**  
**Dennis Schriffert**  
 14175 Fall Creek Court  
 Naples, Florida 34114

Attorney for Personal Representative:  
 Jonas B. Weatherbie  
 E-mail Addresses:  
 jweatherbie@gvtrustlaw.com  
 jjavor@gvtrustlaw.com  
 Florida Bar No. 87968  
 Galbraith Weatherbie Law  
 999 Vanderbilt Beach Road,  
 Suite 509  
 Naples, Florida 34108  
 Telephone: (239) 325-1983  
 Fax: (239) 325-1065  
 September 15, 22, 2023 23-01862C

### FIRST INSERTION

NOTICE TO CREDITORS (Single Personal Representative) IN THE CIRCUIT COURT OF THE 20TH JUDICIAL CIRCUIT IN AND FOR COLLIER COUNTY, FLORIDA  
**File No.: 11-2023-CP-001433-0001**  
**Probate Division:**  
**IN RE: THE ESTATE OF ALBERTO MARTINEZ, Deceased.**

The administration of the Estate of ALBERTO MARTINEZ, deceased, whose date of death was December 9, 2022, File Number: 2023-CP-001433, is pending in the Circuit Court for Collier County, Florida, Probate Division, the address of which is 3315 Tamiami Trail East, Naples, FL 34112-5324. The names and addresses of the Personal Representative and the Personal Representative's attorney are set forth below.

All Creditors of Decedent and other persons having claims or demands against Decedent's Estate, including unmaturred, contingent or unliquidated claims, on whom a copy of this Notice is served must file their claims with this Court WITHIN THE LATER OF 3 MONTHS AFTER THE DATE OF THE FIRST PUBLICATION OF THIS NOTICE OR 30 DAYS AFTER THE DATE OF SERVICE OF A COPY OF THIS NOTICE ON THEM.

All other creditors of the Decedent and other persons having claims or demands against Decedent's Estate, including unmaturred, contingent or unliquidated claims, must file their claims with this Court WITHIN 3 MONTHS AFTER THE DATE OF THE FIRST PUBLICATION OF THIS NOTICE.

ALL CLAIMS NOT FILED WITHIN THE TIME PERIODS SET FORTH IN §733.702 OF THE FLORIDA PROBATE CODE WILL BE FOREVER BARRED.

NOTWITHSTANDING THE TIME PERIODS SET FORTH ABOVE, ANY CLAIM FILED TWO (2) YEARS OR MORE AFTER THE DECEDENT'S DATE OF DEATH IS BARRED.

The date of the first publication of this Notice is September 15, 2023.

**Personal Representative:**  
**/S/ MAIKOL LIMA REYTOR**

730 E. 45TH Street  
 Hialeah, FL 33013  
 Attorney for Personal Representative:  
 ADAM S. GUMSON  
 JUPITER LAW CENTER  
 RiverPlace Professional Center  
 1003 W. Indiantown Road - Suite 210  
 Jupiter, Florida 33458-6851  
 Telephone: (561) 744 - 4600  
 Florida Bar No.: 906948  
 E-mail: asg@jupiterlawcenter.com  
 September 15, 22, 2023 23-01847C

### FIRST INSERTION

NOTICE OF PUBLIC SALE:  
 Last Stop Automotive Services LLC gives Notice of Foreclosure of Lien and intent to sell these vehicles on 09/29/2023 09:00 AM at 6345 LEE ANN LN , Naples, FL 34109 pursuant to subsection 713.78 of the Florida Statutes. Last Stop Automotive Services LLC reserves the right to accept or reject any and/or all bids.  
 3GTRCVE0XAG101175  
 2010 GMC SIERRA C1500 SL  
 September 15, 2023 23-01856C

### FIRST INSERTION

NOTICE OF PUBLIC SALE:  
 BALD EAGLE TOWING AND RECOVERY gives Notice of Foreclosure of Lien and intent to sell these vehicles on 09/29/2023 08:00 AM at 3935 Enterprise Ave , Naples, FL 34104 pursuant to subsection 713.78 of the Florida Statutes. BALD EAGLE TOWING AND RECOVERY reserves the right to accept or reject any and/or all bids.  
 1G4PP5SK6C4147759  
 2012 BUICK VERANO  
 September 15, 2023 23-01857C

FIRST INSERTION

NOTICE TO CREDITORS IN THE CIRCUIT COURT OF THE TWENTIETH JUDICIAL CIRCUIT, IN AND FOR COLLIER COUNTY, FLORIDA  
**PROBATE DIVISION**  
**File # 23-CP-2306**  
**IN RE: THE ESTATE OF THOMAS P. COLGATE Deceased.**

The administration of the estate of Thomas Colgate, deceased, File No. 2023-CP-2306 is pending in the Collier County County, Florida, Probate Division, the address of which is Collier County Clerk of Court and Comptroller, Collier County Government Complex 3315 E. Tamiami Trail N. 34112. The names and addresses of the personal representative and the personal representative's attorney are set forth below.

All creditors of the decedent and other persons having claims or demands against decedent's estate, including unmaturing, contingent or unliquidated claims, on whom a copy of this notice is served must file their claims with this court WITHIN THE LATER OF 3 MONTHS AFTER THE DATE OF THE FIRST PUBLICATION OF THIS NOTICE OR 30 DAYS AFTER THE DATE OF SERVICE OF A COPY OF THIS NOTICE ON THEM.

All other creditors of the decedent and other persons having claims or demands against decedent's estate, including unmaturing, contingent or unliquidated claims, must file their claims with this court WITHIN 3 MONTHS AFTER THE DATE OF THE FIRST PUBLICATION OF THIS NOTICE.  
 ALL CLAIMS NOT SO FILED WILL BE FOREVER BARRED.

The date of first publication of this Notice is September 15, 2023.  
**Personal Representative:**  
**Kenneth Colgate**  
 Attorney for Personal Representative: Brian McNamara, Esq. Florida Bar No. 98022 McNamara Legal Services, P.A. 5425 Park Central Court, Naples, FL 34109 Telephone: 239-204-4767 September 15, 22, 2023 23-01829C

FIRST INSERTION

NOTICE UNDER FICTITIOUS NAME LAW Pursuant to F.S. §865.09 NOTICE IS HEREBY GIVEN that the undersigned, desiring to engage in business under the fictitious name of Ledo Pizza Ave Maria, located at 5890 Berwick Lane, in the City of Ave Maria, County of Collier, State of FL, 34142, intends to register the said name with the Division of Corporations of the Florida Department of State, Tallahassee, Florida.

Dated this 8 of September, 2023.  
**DREAMS & PIZZA LLC**  
 5890 Berwick Lane  
 Ave Maria, FL 34142  
 September 15, 2023 23-01846C

FIRST INSERTION

Notice is hereby given that DIMENSIONS DENTAL DESIGN INC, OWNER, desiring to engage in business under the fictitious name of DIMENSIONS DENTAL DESIGN INC located at 696 GOODLETTE FRANK RD N., NAPLES, FLORIDA 34102 intends to register the said name in COLLIER county with the Division of Corporations, Florida Department of State, pursuant to section 865.09 of the Florida Statutes.

September 15, 2023 23-01854C

FIRST INSERTION

NOTICE OF PUBLIC SALE: BEST TOWING INC gives notice that on 10/13/2023 at 08:00 AM the following vehicle(s) may be sold by public sale at 3573 ARNOLD AVE NAPLES, FL 34104 to satisfy the lien for the amount owed on each vehicle for any recovery, towing, or storage services charges and administrative fees allowed pursuant to Florida statute 713.78. 1D7HA16K14J281469 2004 DODG

September 15, 2023 23-01845C

FIRST INSERTION

Notice is hereby given that ANTHONY SPANO, OWNER, desiring to engage in business under the fictitious name of YOUR HOME MEDIA located at 4601 EVERGREEN LAKE ROAD, NAPLES, FLORIDA 34112 intends to register the said name in COLLIER county with the Division of Corporations, Florida Department of State, pursuant to section 865.09 of the Florida Statutes.

September 15, 2023 23-01852C

FIRST INSERTION

Notice is hereby given that EDDIE TOVAR, OWNER, desiring to engage in business under the fictitious name of HOHM ELECTRIC located at 5850 STANDING OAKS LN, NAPLES, FLORIDA 34119 intends to register the said name in COLLIER county with the Division of Corporations, Florida Department of State, pursuant to section 865.09 of the Florida Statutes.

September 15, 2023 23-01853C

FIRST INSERTION

KEITH'S TOWING INC. 903 ALACHUA ST. IMMOKALEE, FLORIDA 34142 (239) 657-5741 AUCTION DATE- OCTOBER 09, 2023 @9AM 2000 FORD 1FTRX18L2YKA41446 2012 TOYOTA 5YFBU4EE6CP014536 2015 DODGE IC4RDHAG4FC201865 2010 COOLSTER DIRTBIKE L6ZDCJLA2M1003542

September 15, 2023 23-01851C

FIRST INSERTION

NOTICE TO CREDITORS (Summary Administration) IN THE CIRCUIT COURT FOR COLLIER COUNTY, FLORIDA  
**PROBATE DIVISION**  
**File No. 23-CP-2579**  
**Division Probate**  
**IN RE: ESTATE OF PETER SWAUFIELD Deceased.**

TO ALL PERSONS HAVING CLAIMS OR DEMANDS AGAINST THE ABOVE ESTATE:

You are hereby notified that an Order of Summary Administration has been entered in the estate of Peter Swafield, deceased, File Number 23-CP-2579, by the Circuit Court for Collier County, Florida, Probate Division, the address of which is 3315 Tamiami Trail East, Naples, FL 34112-5324; that the decedent's date of death was October 18, 2022; that the total value of the estate is \$500 and that the names and addresses of those to whom it has been assigned by such order are:

Name	Address
Patricia A. Swauffield	2510 Sailors Way Naples, FL 34109

ALL INTERESTED PERSONS ARE NOTIFIED THAT:

All creditors of the estate of the decedent and persons having claims or demands against the estate of the decedent

other than those for whom provision for full payment was made in the Order of Summary Administration must file their claims with this court WITHIN THE TIME PERIODS SET FORTH IN FLORIDA STATUTES SECTION 733.702. ALL CLAIMS AND DEMANDS NOT SO FILED WILL BE FOREVER BARRED. NOTWITHSTANDING ANY OTHER APPLICABLE TIME PERIOD, ANY CLAIM FILED TWO (2) YEARS OR MORE AFTER THE DECEDENT'S DATE OF DEATH IS BARRED.

The date of first publication of this Notice is September 15, 2023.

**Person Giving Notice:**  
**Patricia A. Swauffield**  
 2510 Sailors Way  
 Naples, Florida 34109  
 Attorney for Person Giving Notice Christina B. Davidow, Esq. Attorney Florida Bar Number: 66356 Willis & Davidow, Attorneys at Law, LLC 9015 Strada Stell Ct. Suite 106 Naples, FL 34109 Telephone: (239) 465-0531 Fax: (888) 435-0911 E-Mail: cdavidow@willisdavidow.com Secondary E-Mail: dimm@willisdavidow.com September 15, 22, 2023 23-01848C

FIRST INSERTION

NOTICE TO CREDITORS IN THE CIRCUIT COURT FOR COLLIER COUNTY, FLORIDA  
**PROBATE DIVISION**  
**File No. 23-CP-2603**  
**Division 02**  
**IN RE: ESTATE OF JOHN C. LUJACK Deceased.**

The administration of the estate of John C. Lujack, deceased, whose date of death was July 25, 2023, is pending in the Circuit Court for Collier County, Florida, Probate Division, the address of which is 3315 Tamiami Trail E, Suite 102, Naples, FL 34112. The names and addresses of the personal representative and the personal representative's attorney are set forth below.

All creditors of the decedent and other persons having claims or demands against decedent's estate on whom a copy of this notice is required to be served must file their claims with this court ON OR BEFORE THE LATER OF 3 MONTHS AFTER THE TIME OF THE FIRST PUBLICATION OF THIS NOTICE OR 30 DAYS AFTER THE DATE OF SERVICE OF A COPY OF THIS NOTICE ON THEM.

All other creditors of the decedent and other persons having claims or demands against decedent's estate must

file their claims with this court WITHIN 3 MONTHS AFTER THE DATE OF THE FIRST PUBLICATION OF THIS NOTICE.

ALL CLAIMS NOT FILED WITHIN THE TIME PERIODS SET FORTH IN FLORIDA STATUTES SECTION 733.702 WILL BE FOREVER BARRED.

NOTWITHSTANDING THE TIME PERIODS SET FORTH ABOVE, ANY CLAIM FILED TWO (2) YEARS OR MORE AFTER THE DECEDENT'S DATE OF DEATH IS BARRED.

The date of first publication of this notice is September 15, 2023.

**Personal Representative:**  
**Mary Jane Lujack**  
 915 Seaside Drive  
 Sarasota, FL 34242  
 Attorney for Personal Representative: Kenneth D. Goodman, Attorney Florida Bar Number: 775710 GOODMAN BREEN 3838 Tamiami Trail N, Suite 300 Naples, FL 34103 Telephone: (239) 403-3000 Fax: (239) 403-0010 E-Mail: kgoodman@goodmanbreen.com Secondary E-Mail: gbprobate@gmail.com September 15, 22, 2023 23-01868C

FIRST INSERTION

NOTICE TO CREDITORS IN THE CIRCUIT COURT FOR COLLIER COUNTY, FLORIDA  
**PROBATE DIVISION**  
**File No. 23-CP-2230**  
**Division Probate**  
**IN RE: ESTATE OF RUBY M. MERIWEATHER Deceased.**

The administration of the estate of Ruby M. Meriweather, deceased, whose date of death was July 12, 2023, is pending in the Circuit Court for Collier County, Florida, Probate Division, the address of which is 3315 Tamiami Trail E., Naples, FL 34112. The names and addresses of the personal representative and the personal representative's attorney are set forth below.

All creditors of the decedent and other persons having claims or demands against decedent's estate on whom a copy of this notice is required to be served must file their claims with this court ON OR BEFORE THE LATER OF 3 MONTHS AFTER THE TIME OF THE FIRST PUBLICATION OF THIS NOTICE OR 30 DAYS AFTER THE DATE OF SERVICE OF A COPY OF THIS NOTICE ON THEM.

All other creditors of the decedent

and other persons having claims or demands against decedent's estate must file their claims with this court WITHIN 3 MONTHS AFTER THE DATE OF THE FIRST PUBLICATION OF THIS NOTICE.

ALL CLAIMS NOT FILED WITHIN THE TIME PERIODS SET FORTH IN FLORIDA STATUTES SECTION 733.702 WILL BE FOREVER BARRED.

NOTWITHSTANDING THE TIME PERIODS SET FORTH ABOVE, ANY CLAIM FILED TWO (2) YEARS OR MORE AFTER THE DECEDENT'S DATE OF DEATH IS BARRED.

The date of first publication of this notice is September 15, 2023.

**Personal Representative:**  
**Pearl Wout**  
 9644 Cold Star Court  
 Columbia, MD 21046  
 Attorney for Personal Representative: Abigail Mason, Attorney Florida Bar Number: 1040206 Lyons & Lyons, PA. 27911 Crown Lake Boulevard Ste 201 Bonita Springs, FL 34135 Telephone: (239) 948-1823 Fax: (239) 948-1826 E-Mail: amason@lyons-law.com September 15, 22, 2023 23-01864C

FIRST INSERTION

NOTICE OF ACTION FOR Initial Action/Petition IN THE CIRCUIT COURT OF THE JUDICIAL CIRCUIT, IN AND FOR Collier County, FLORIDA  
**Case No.: 23 DR 1513**

**Jessica Chambers, Petitioner and Andrew Chambers, Respondent.**  
 TO: Andrew Chambers 998 S Main St Mansfield OH 44907

YOU ARE NOTIFIED that an action for Dissolution of Marriage has been filed against you and that you are required to serve a copy of your written defenses, if any, to it on Jessica Chambers, whose address is 732 Broad Court North Naples Florida 34102 on or before 10/13/2023, and file the original with the clerk of this Court at 3315 Tamiami, Trail East, Naples, Florida, 34112 before service on Petitioner or immediately thereafter. If you fail to do so, a default may be entered against you for the relief demanded in the petition.

Copies of all court documents in this case, including orders, are available at the Clerk of the Circuit Court's office. You may review these documents upon request.

You must keep the Clerk of the Circuit Court's office notified of your current address. (You may file Designation of Current Mailing and E-Mail Address, Florida Supreme Court Approved Family Law Form 12.915.) Future papers in this lawsuit will be mailed or e-mailed to the addresses on record at the clerk's office.

WARNING: Rule 12.285, Florida Family Law Rules of Procedure, requires certain automatic disclosure of documents and information. Failure to comply can result in sanctions, including dismissal or striking of pleadings. Dated: Sep 08 2023.

CLERK OF THE CIRCUIT COURT (Seal) By: Yliana Mirabal Deputy Clerk  
 Sept. 15, 22, 29; Oct. 6, 2023 23-01860C

FIRST INSERTION

NOTICE TO CREDITORS IN THE CIRCUIT COURT OF THE TWENTIETH JUDICIAL CIRCUIT IN AND FOR COLLIER COUNTY, FLORIDA  
**PROBATE DIVISION**  
**CASE NO.: 23-CP-2616**  
**IN RE: THE ESTATE OF ANDRIES STELLINGSMA Deceased.**

The administration of the estate of ANDRIES STELLINGSMA, deceased, whose date of death was August 17, 2023, is pending in the Circuit Court for Collier County, Florida, Probate Division, the address of which is 3315 Tamiami Trail East, Suite 102, Naples, FL 34112. The names and addresses of the personal representative and the personal representative's attorney are set forth below.

All creditors of the decedent and other persons having claims or demands against decedent's estate on whom a copy of this notice is required to be served must file their claims with this court ON OR BEFORE THE LATER OF 3 MONTHS AFTER THE TIME OF THE FIRST PUBLICATION OF THIS NOTICE OR 30 DAYS AFTER THE DATE OF SERVICE OF A COPY OF THIS NOTICE ON THEM.

All other creditors of the decedent and other persons having claims or demands against decedent's estate must file their claims with this court WITHIN 3 MONTHS AFTER THE DATE OF

THE FIRST PUBLICATION OF THIS NOTICE.

ALL CLAIMS NOT FILED WITHIN THE TIME PERIODS SET FORTH IN FLORIDA STATUTES SECTION 733.702 WILL BE FOREVER BARRED.

NOTWITHSTANDING THE TIME PERIODS SET FORTH ABOVE, ANY CLAIM FILED TWO (2) YEARS OR MORE AFTER THE DECEDENT'S DATE OF DEATH IS BARRED.

The date of first publication of this notice is September 15, 2023.

**Personal Representative:**  
**CYNTHIA GRACE DEAL**  
 2906 Laramie Avenue  
 San Ramon, CA 94583

Attorney for Personal Representative: DAVID R. PASH Florida Bar No. 484679 Email: dpash@wga-law.com Alternate Email: pleadings@wga-law.com LISA B. GODDY Florida Bar No. 0507075 Email: lgoddy@wga-law.com Alternate Email: pleadings@wga-law.com Attorneys for Personal Representative WOLLMAN, GEHRKE & ASSOCIATES, PA 2235 Venetian Court, Suite 5 Naples, FL 34109 Telephone: (239) 435-1533 Facsimile: (239) 435-1433 September 15, 22, 2023 23-01839C

FIRST INSERTION

NOTICE TO CREDITORS IN THE CIRCUIT COURT FOR COLLIER COUNTY, FLORIDA  
**PROBATE DIVISION**  
**File No. 23-CP-2604**  
**IN RE: ESTATE OF HJERKE KUPERUS, aka JERRY KUPERUS Deceased.**

The administration of the estate of HJERKE KUPERUS, also known as JERRY KUPERUS, deceased, whose date of death was August 22, 2023, is pending in the Circuit Court for Collier County, Florida, Probate Division, the address of which is 3315 Tamiami Trl E., Suite 102, Naples, FL 34112. The names and addresses of the personal representative and the personal representative's attorney are set forth below.

All creditors of the decedent and other persons having claims or demands against decedent's estate, on whom a copy of this notice is required to be served, must file their claims with this court ON OR BEFORE THE LATER OF 3 MONTHS AFTER THE TIME OF THE FIRST PUBLICATION OF THIS NOTICE OR 30 DAYS AFTER THE DATE OF SERVICE OF A COPY OF THIS NOTICE ON THEM.

All other creditors of the decedent and other persons having claims or demands against decedent's estate must

file their claims with this court WITHIN 3 MONTHS AFTER THE DATE OF THE FIRST PUBLICATION OF THIS NOTICE.

ALL CLAIMS NOT FILED WITHIN THE TIME PERIODS SET FORTH IN FLORIDA STATUTES SECTION 733.702 WILL BE FOREVER BARRED.

NOTWITHSTANDING THE TIME PERIOD SET FORTH ABOVE, ANY CLAIM FILED TWO (2) YEARS OR MORE AFTER THE DECEDENT'S DATE OF DEATH IS BARRED.

The date of first publication of this notice is: September 15, 2023.  
 Signed on this 12th day of September, 2023.

/s/ Thomas F. Hudgins, Esq.  
**THOMAS F. HUDGINS, ESQ.**  
**Personal Representative**  
 2800 Davis Blvd., Ste.: 203  
 Naples, FL 34104

/s/ Thomas F. Hudgins, Esq. Attorney for Personal Representative Florida Bar No. 970565 Thomas F. Hudgins, PLLC 2800 Davis Blvd., Ste.: 203 Naples, FL 34104 Telephone: 239-263-7660 Email: ted@naplestax.com Secondary Email: service@naplestax.com September 15, 22, 2023 23-01861C

FIRST INSERTION

NOTICE TO CREDITORS IN THE CIRCUIT COURT OF THE TWENTIETH JUDICIAL CIRCUIT IN AND FOR COLLIER COUNTY, FLORIDA  
**PROBATE DIVISION**  
**File No. 23-CP-2601**  
**IN RE: ESTATE OF CARL TAYLOR STEPLING Deceased.**

The administration of the estate of CARL TAYLOR STEPLING, deceased, whose date of death was May 11, 2023, is pending in the Circuit Court for Collier County, Florida, Probate Division, the address of which is 3315 Tamiami Trail East, Ste. 102, Naples, Florida 34112. The names and addresses of the personal representative and the personal representative's attorney are set forth below.

All creditors of the decedent and other persons having claims or demands against decedent's estate on whom a copy of this notice is required to be served must file their claims with this court ON OR BEFORE THE LATER OF 3 MONTHS AFTER THE TIME OF THE FIRST PUBLICATION OF THIS NOTICE OR 30 DAYS AFTER THE DATE OF SERVICE OF A COPY OF THIS NOTICE ON THEM.

All other creditors of the decedent and other persons having claims or demands against decedent's estate must file their claims with this court WITH-

IN 3 MONTHS AFTER THE DATE OF THE FIRST PUBLICATION OF THIS NOTICE.

ALL CLAIMS NOT FILED WITHIN THE TIME PERIODS SET FORTH IN FLORIDA STATUTES SECTION 733.702 WILL BE FOREVER BARRED.

NOTWITHSTANDING THE TIME PERIODS SET FORTH ABOVE, ANY CLAIM FILED TWO (2) YEARS OR MORE AFTER THE DECEDENT'S DATE OF DEATH IS BARRED.

The date of first publication of this notice is September 15, 2023.

**Personal Representative:**  
**TAYLOR JACK STEPLING**  
 6601 South Westshore Blvd., Apt. 3412  
 Tampa, Florida 33616

Attorney for Personal Representative: EDWARD E. WOLLMAN Florida Bar Number: 618640 PATRICK COURVILLE Florida Bar Number: 115708 Attorneys for Petitioner WOLLMAN GEHRKE & ASSOCIATES, P.A. 2235 Venetian Court, Suite 5 Naples, Florida 34109 Telephone: (239) 435-1533 Fax: (239) 435-1433 E-Mail: ewollman@wga-law.com pcourville@wga-law.com Secondary E-Mail: pleadings@wga-law.com September 15, 22, 2023 23-01840C

FIRST INSERTION

NOTICE OF PUBLIC SALE: MORLEYS TOWING OF NAPLES gives notice that on 09/28/2023 at 10:00 AM the following vehicle(s) may be sold by public sale at 6344 JAMES LANE, NAPLES, FL 34109 to satisfy the lien for the amount owed on each vehicle for any recovery,

towing, or storage services charges and administrative fees allowed pursuant to Florida statute 713.78. 1B3CB4HA1AD668171 2010 DODG 2T2ZKI8A4AC014337 2010 LEXS JM3TB2MA6A0219267 2010 MAZD KNAFK4A62F5348907 2015 KIA  
 September 15, 2023 23-01836C

FIRST INSERTION

Notice Under Fictitious Name Law According to Florida Statute Number 865.09 NOTICE IS HEREBY GIVEN that the undersigned, desiring to engage in business under the Fictitious Name of EverPlantium located at 4391 Golden Gate Blvd E in the City of Naples,

Collier County, FL 34120 intends to register the said name with the Division of Corporations of the Department of State, Tallahassee, Florida. Dated this 12th day of September, 2023. Kristen Wells  
 September 15, 2023 23-01859C

**OFFICIAL COURTHOUSE WEBSITES**

MANATEE COUNTY  
*manateeclerk.com*

SARASOTA COUNTY  
*sarasotaclerk.com*

CHARLOTTE COUNTY  
*charlotteclerk.com*

LEE COUNTY  
*leeclerk.org*

COLLIER COUNTY  
*collierclerk.com*

HILLSBOROUGH COUNTY  
*hillsclerk.com*

PASCO COUNTY  
*pascoclerk.com*

PINELLAS COUNTY  
*pinellasclerk.org*

POLK COUNTY  
*polkcountyclerk.net*

ORANGE COUNTY  
*myorangeclerk.com*

FLORIDA'S NEWSPAPER FOR THE C-SUITE

**Business Observer**

LV20890\_V-5

**SAVE TIME**

**Email your Legal Notice**  
*legal@businessobserverfl.com*

*Deadline Wednesday at noon  
 Friday Publication*

SARASOTA • MANATEE  
 HILLSBOROUGH • PASCO  
 PINELLAS • POLK • LEE  
 COLLIER • CHARLOTTE

**Business Observer**

FIRST INSERTION

NOTICE OF FORECLOSURE SALE IN THE CIRCUIT COURT OF THE TWENTIETH JUDICIAL CIRCUIT IN AND FOR COLLIER COUNTY, FLORIDA  
**CASE NO.:**  
**11-2019-CA-000847-0001-XX**  
**THE BANK OF NEW YORK MELLON FKA THE BANK OF NEW YORK AS TRUSTEE FOR THE CERTIFICATEHOLDERS OF THE CWALT, INC., ALTERNATIVE LOAN TRUST 2007-0A4 MORTGAGE PASS-THROUGH CERTIFICATES, SERIES 2007-0A4,**  
**Plaintiff, vs.**  
**ALEXANDER GOMEZ A/K/A ALEXANDER H. GOMEZ; CLAUDIA P. GOMEZ; MORTGAGE ELECTRONIC REGISTRATION SYSTEMS INC.**  
**(MIN#100133700019675266); GOLDEN GATE ESTATES AREA CIVIC ASSOCIATION, INC; UNKNOWN TENANT(S) IN POSSESSION #1 and #2, and ALL OTHER UNKNOWN PARTIES, Defendant(s).**  
 NOTICE IS HEREBY GIVEN pursuant to a Final Summary Judgment of Foreclosure dated August 30, 2023, entered in Civil Case No.: 11-2019-CA-000847-0001-XX of the Circuit Court of the Seventh Judicial Circuit in and for Flagler County, Florida, wherein THE BANK OF NEW YORK MELLON FKA THE BANK OF NEW YORK AS TRUSTEE FOR THE CERTIFICATEHOLDERS OF THE CWALT, INC., ALTERNATIVE LOAN TRUST 2007-0A4 MORTGAGE PASS-THROUGH CERTIFICATES, SERIES 2007-0A4, Plaintiff, and ALEXANDER GOMEZ A/K/A ALEXANDER H. GOMEZ; CLAUDIA P. GOMEZ; MORTGAGE ELECTRONIC REGISTRATION SYSTEMS INC. (MIN#100133700019675266); GOLDEN GATE ESTATES AREA CIVIC ASSOCIATION, INC; UNKNOWN TENANT(S) IN POSSESSION #1 N/K/A YENNI HERNANDEZ, are Defendants.  
 CRYSTAL K. KINZEL, The Clerk of the Circuit Court, will sell to the highest

bidder for cash, in the lobby on the third floor of the Courthouse Annex, Collier County Courthouse, 3315 Tamiami Trail East, Naples, FL 34112, at 11:00 AM, on the 18th day of January, 2024, the following described real property as set forth in said Judgment, to wit:  
 THE EAST 1/2 OF TRACT 42, GOLDEN GATE ESTATES UNIT NO. 41, ACCORDING TO THE PLAT THEREOF AS RECORDED IN PLAT BOOK 7, PAGE 26, OF THE PUBLIC RECORDS OF COLLIER COUNTY, FLORIDA.  
 If you are a person claiming a right to funds remaining after the sale, you must file a claim with the clerk before the clerk reports the surplus as unclaimed. If you fail to file a timely claim you will not be entitled to any remaining funds. After the funds are reported as unclaimed, only the owner of record as of the date of the Lis Pendens may claim the surplus.  
 If you are a person with a disability who needs any accommodation in order to participate in this proceeding, you are entitled, at no cost to you, to the provision of certain assistance. Please contact Charles Rice, Administrative Services Manager, whose office is located at 3315 East Tamiami Trail, Suite 501, Naples, Florida 34112, and whose telephone number is (239) 252-8800, at least 7 days before your scheduled court appearance, or immediately upon receiving this notification if the time before the scheduled appearance is less than 7 days; if you are hearing or voice impaired, call 711.  
 Dated: September 12, 2023  
 /s/ Brian L. Rosaler  
 By: Brian L. Rosaler  
 Florida Bar No.: 0174882.  
 Attorney for Plaintiff:  
 Brian L. Rosaler, Esquire  
 Popkin & Rosaler, P.A.  
 1701 West Hillsboro Boulevard  
 Suite 400  
 Deerfield Beach, FL 33442  
 Telephone: (954) 360-9030  
 Facsimile: (954) 420-5187  
 18-47301  
 September 15, 22, 2023 23-01863C

FIRST INSERTION

NOTICE OF PUBLIC AUCTION/ SALE FOR NON-JUDICIAL TIMESHARE FORECLOSURE RE: VANDERBILT BEACH & HARBOUR CLUB CONDOMINIUM ASSOCIATION, INC. COLLIER County, Florida  
 Non-Judicial Timeshare foreclosure process  
 NOTICE IS HEREBY GIVEN that, pursuant to an action for non-judicial foreclosure of timeshare units on the Claim of Lien, which is dated April 14, 2023 and was recorded April 27, 2023, in the Official Records of Collier County, Florida at OR Book 6240, Page 3368 as Instrument Number 6395233, I will sell, to the highest and best bidder for cash, at VANDERBILT BEACH & HARBOUR CLUB Manager's Office, 9301 Gulf Shore Drive, Naples, FL 34108 on the 27th day of SEPTEMBER, 2023, at 11:00 a.m., the following described real property located in Collier County, Florida, to-wit:  
 Unit Numbers and Week Numbers as set forth below in VANDERBILT BEACH & HARBOUR CLUB, a Condominium, according to the Declaration of Condominium thereof, as recorded in Official Records Book 968, Page 1096, of the Public Records of Collier County, Florida, and all amendments thereto, if any.  
 Unit Number: Week Number:  
 102 39, 49  
 208 44  
 211 43  
 305 22  
 411 49  
 512 38  
 TO: Owner(s)  
 Address  
 Unit /Week Number(s)  
 Amount due:  
 Joseph Redding Kremiski  
 Estate of Joseph Redding Kremiski  
 All heirs and devisees of the Estate of Joseph Redding Kremiski  
 20 40 Chipman Street, Apt #3  
 Owosso, MI 48867-4753  
 512/38  
 \$3,132.37 with a per diem amount of \$1.54 from February 3, 2023  
 John W Hinkle and Petra R Hinkle  
 1615 Pleasant View Road  
 Hastings, MI 49058

102/49  
 \$4,067.65 with a per diem amount of \$2.00 from February 3, 2023  
 Richard L Stevens and Karen R Stevens  
 26922 Chateau Du Lac Court  
 Bonita Springs, FL 33923-5019  
 208/44  
 \$3,431.28 with a per diem amount of \$1.69 from February 3, 2023  
 Richard D Lefevre and Betty B Lefevre  
 a/k/a Betty B Lefevre  
 4863 Evans Court Apt 246  
 Trenton, MI 48183  
 411/49  
 \$3,278.82 with a per diem amount of \$1.62 from February 3, 2023  
 Albertha Woodbury Wright  
 1673 NW 192nd Terrace  
 Miami, FL 33169  
 305/22  
 \$3,132.37 with a per diem amount of \$1.54 from February 3, 2023  
 Wallace Eugene Blanchard and Gloria Blanchard  
 40 Shore Drive  
 Mahopac, NY 10541  
 102/39  
 \$3,106.69 with a per diem amount of \$1.53 from February 3, 2023  
 James Van Carteren and Lucille Van Carteren  
 3310 South Ocean Blvd, Apt 626  
 Highland Beach, FL 33487  
 211/43  
 \$2,803.24 with a per diem amount of \$1.38 from February 3, 2023  
 The assessment lien created by the Claims of Lien was properly created and authorized pursuant to the timeshare instrument and applicable law, and the amounts secured by said lien are as set above.  
 You may cure the default at any time prior to the public auction by paying the amount due, as set forth in this notice, to the undersigned Trustee at the address set forth below.  
 THOMAS L AVRUTIS, ESQUIRE  
 TRUSTEE FOR VANDERBILT BEACH & HARBOUR CLUB CONDOMINIUM ASSOCIATION, INC  
 201 Fletcher Avenue, Second Floor  
 Sarasota, FL 34237  
 Telephone (941) 955-7300  
 Facsimile (941) 953-7625  
 State of FLORIDA  
 County of SARASOTA  
 September 15, 22, 2023 23-01849C

FIRST INSERTION

NOTICE UNDER FICTITIOUS NAME LAW PURSUANT TO SECTION 865.09, FLORIDA STATUTES  
 NOTICE IS HEREBY GIVEN that Serena Barreau / DEVI YACHT MANAGEMENT will engage in business under the fictitious name SKIN SOLUTIONS BY SERENA, with a physical address 4038 gulf shore blvd ste 804 Naples, FL 34104, with a mailing address 2020 Bayside Pkwy Fort Myers, FL 33901, and already registered the name mentioned above with the Florida Department of State, Division of Corporations.  
 September 15, 2023 23-01866C

NOTICE Under Fictitious Name Law Pursuant to Section 865.09, Florida Statutes  
 NOTICE IS HEREBY GIVEN that the undersigned, desiring to engage in business under the fictitious name of Nobleman Threads located at 5211 Vizcaya St, in the County of Collier, in the City of Ave Maria, Florida 34142 intends to register the said name with the Division of Corporations of the Florida Department of State, Tallahassee, Florida.  
 Dated at Ave Maria, Florida, this 8th day of September, 2023.  
 Tyler Morehead  
 September 15, 2023 23-01850C

FIRST INSERTION

RE-NOTICE OF SALE PURSUANT TO CHAPTER 45 IN THE CIRCUIT COURT OF THE TWENTIETH JUDICIAL CIRCUIT IN AND FOR COLLIER COUNTY, FLORIDA.  
 CIVIL DIVISION  
**CASE NO.**  
**112016CA0009100001XX**  
**U.S. BANK, NATIONAL ASSOCIATION AS LEGAL TITLE TRUSTEE FOR TRUMAN 2016 SC6 TITLE TRUST,**  
**Plaintiff, vs.**  
**ARBEN LALA AKA ARBEN LOPEZ DE LALA; MARIA F. LOPEZ AKA MARIA FERNANDA LOPEZ; KLARITA IVANAJ; ALBERT IVANAJ; UNKNOWN TENANT #1; UNKNOWN TENANT #2 UNKNOWN TENANT NO. 1; UNKNOWN TENANT NO. 2; and ALL UNKNOWN PARTIES CLAIMING INTERESTS BY, THROUGH, UNDER OR AGAINST A NAMED DEFENDANT TO THIS ACTION, OR HAVING OR CLAIMING TO HAVE ANY RIGHT, TITLE OR INTEREST IN THE PROPERTY HEREIN DESCRIBED, Defendant(s).**  
 NOTICE IS HEREBY GIVEN pursuant to an Order or Summary Final Judgment of foreclosure dated August 7, 2017 and an Order Resetting Sale dated August 25, 2023 and entered in Case No. 112016CA0009100001XX of the Circuit Court in and for Collier County, Florida, wherein U.S. BANK, NATIONAL ASSOCIATION AS LEGAL TITLE TRUSTEE FOR TRUMAN 2016 SC6 TITLE TRUST is Plaintiff and ARBEN LALA AKA ARBEN LOPEZ DE LALA; MARIA F. LOPEZ AKA MARIA FERNANDA LOPEZ; KLARITA IVANAJ; ALBERT IVANAJ; UNKNOWN TENANT #1; UNKNOWN TENANT #2 UNKNOWN TENANT NO. 1; UNKNOWN TENANT NO. 2; and ALL UNKNOWN PARTIES CLAIMING INTERESTS BY, THROUGH, UNDER OR AGAINST A NAMED DEFENDANT TO THIS ACTION, OR HAVING OR CLAIMING TO HAVE ANY RIGHT, TITLE OR INTEREST IN THE PROPERTY HEREIN DESCRIBED, are Defendants, CRYSTAL K KINZEL, Clerk of the Circuit Court, will sell to the highest and best bidder

for cash the lobby on the third floor of the Courthouse Annex, Collier County Courthouse, 3315 Tamiami Trail East, Naples, FL 34112, 11:00 a.m., on September 28, 2023, the following described property as set forth in said Order or Final Judgment, to-wit:  
 Golden Gate Estates, Unit 33, as recorded in Plat Book 7, Page 60, Public Records of Collier County, Florida  
 ANY PERSON CLAIMING AN INTEREST IN THE SURPLUS FROM THE SALE, IF ANY, OTHER THAN THE PROPERTY OWNER AS OF THE DATE OF THE LIS PENDENS MUST FILE A CLAIM BEFORE THE CLERK REPORTS THE SURPLUS AS UNCLAIMED. THE COURT, IN ITS DISCRETION, MAY ENLARGE THE TIME OF THE SALE. NOTICE OF THE CHANGED TIME OF SALE SHALL BE PUBLISHED AS PROVIDED HEREIN.  
 Pursuant to Florida Statute 45.031(2), this notice shall be published twice, once a week for two consecutive weeks, with the last publication being at least 5 days prior to the sale.  
 If you are a person with a disability who needs any accommodation in order to participate in this proceeding, you are entitled, at no cost to you, to the provision of certain assistance. Please contact the Administrative Services Manager whose office is located at 3301 East Tamiami Trail, Bldg L, Naples, FL 34112, and whose telephone number is (239) 252-8800, at least 7 days before your scheduled court appearance, or immediately upon receiving this notification if the time before the scheduled appearance is less than 7 days; if you are hearing or voice impaired, call 711.  
 DATED September 12, 2023.  
 By: /s/ Ian Dolan  
 Ian C. Dolan  
 Florida Bar No.: 757071  
 Roy Diaz, Attorney of Record  
 Florida Bar No. 767700  
 Diaz Anselmo & Associates, P.A.  
 Attorneys for Plaintiff  
 499 NW 70th Ave., Suite 309  
 Fort Lauderdale, FL 33317  
 Telephone: (954) 564-0071  
 Facsimile: (954) 564-9252  
 Service E-mail: answers@dallegal.com  
 1460-161145 / BJB  
 September 15, 22, 2023 23-01867C

FIRST INSERTION

NOTICE OF PUBLIC SALE: GETTING HOOKED TOWING gives notice that on 09/27/2023 at 08:00 AM the following vehicles(s) may be sold by public sale at 4344 ENTERPRISE AVE STE 5 NAPLES FL 34104 to satisfy the lien for the amount owed on each vehicle for any recovery, towing, or storage services charges and administrative fees allowed pursuant to Florida statute 713.78.  
 G57455CHO4497B HOMEMADE UTILITY TRAILER  
 WBXP73414WB28260 2004 BMW  
 September 15, 2023 23-01831C

FIRST INSERTION

NOTICE OF PUBLIC SALE: GETTING HOOKED TOWING gives notice that on 10/02/2023 at 08:00 AM the following vehicles(s) may be sold by public sale at 4344 ENTERPRISE AVE STE 5 NAPLES FL 34104 to satisfy the lien for the amount owed on each vehicle for any recovery, towing, or storage services charges and administrative fees allowed pursuant to Florida statute 713.78.  
 1GCCS14X9XK128904 1999 CHEV 2HGF12806H557690 2006 HOND 5TDZ22C25S292214 2005 TOYT  
 September 15, 2023 23-01832C

FIRST INSERTION

Extra Space Storage will hold a public auction to sell personal property described below belonging to those individuals listed below at the location indicated:  
 10550 Goodlette-Frank Rd.  
 Naples FL 34109  
 on 10/03/2023 at 11:30AM  
 Charles Hood -  
 Furniture and appliances  
 The auction will be listed and advertised on www.storage-treasures.com. Purchases must be made with cash only and paid at the above referenced facility in order to complete the transaction. Extra Space Storage may refuse any bid and may rescind any purchase up until the winning bidder takes possession of the personal property.  
 September 15, 22, 2023 23-01830C

FIRST INSERTION

NOTICE OF PUBLIC SALE: BALD EAGLE TOWING AND RECOVERY gives Notice of Foreclosure of Lien and intent to sell these vehicles on 10/02/2023 08:00 AM at 3935 Enterprise Ave, Naples, FL 34104 pursuant to subsection 713.78 of the Florida Statutes. BALD EAGLE TOWING AND RECOVERY reserves the right to accept or reject any and/or all bids.  
 3FAHPOJG2BR125679  
 2011 FORD FUSION SEL  
 1GDC14K2KZ278570  
 1989 CHEVROLET C1500  
 September 15, 2023 23-01833C

FIRST INSERTION

NOTICE OF PUBLIC SALE: BALD EAGLE TOWING & RECOVERY, INC. gives notice that on 10/03/2023 at 08:00 AM the following vehicles(s) may be sold by public sale at 3935 ENTERPRISE AVENUE NAPLES, FLORIDA 34104 to satisfy the lien for the amount owed on each vehicle for any recovery, towing, or storage services charges and administrative fees allowed pursuant to Florida statute 713.78.  
 1GKEC16Z85J125973 2005 GMC  
 September 15, 2023 23-01834C

FIRST INSERTION

Notice of Public Sale TO BE HELD AT: THE LOCK UP STORAGE  
 1200 Pine Ridge Road  
 Naples FL 34108  
 239-430-2212  
 pineridge@lockupselfstorage.com  
 DATE: Sept. 27, 2023  
 BEGINS: 11:00am  
 CONDITIONS: All units will be sold to the highest bidder. Bids taken only for each unit in its entirety. Payment must be cash only. No personal checks accepted. All goods must be removed from the unit within 24 hours. Payment due immediately upon acceptance of bid. Unit availability subject to prior settlement of account.  
 Unit G311,  
 SW Florida Mortgage Solutions, Inc.  
 Agent Marisa McDougall,  
 Boxes, table.  
 Unit H312, Sean Spector,  
 furniture, suitcases, tables, rugs.  
 September 15, 2023 23-01835C

FIRST INSERTION

NOTICE OF PUBLIC SALE: BALD EAGLE TOWING AND RECOVERY gives Notice of Foreclosure of Lien and intent to sell these vehicles on 10/02/2023 08:00 AM at 3935 Enterprise Ave, Naples, FL 34104 pursuant to subsection 713.78 of the Florida Statutes. BALD EAGLE TOWING AND RECOVERY reserves the right to accept or reject any and/or all bids.  
 1FTMF1CP3HFA20959  
 2017 FORD F150  
 1GDC14K2KZ278570  
 1989 CHEVROLET C1500  
 September 15, 2023 23-01858C

SUBSEQUENT INSERTIONS

FOURTH INSERTION

FLORIDA SOUTHWESTERN STATE COLLEGE (FSW) Request for Qualifications (RFQ) #23-03  
 Project Name: Construction Services College Wide: Annual/2024 Prequalification for Projects of all Dollar Levels  
 RFQ Submittal: PRIOR to 2:00 PM ET Tuesday 9/26/23; Electronic submission via:  
 https://www.bidnetdirect.com/florida/floridasouthwestern  
 Public Evaluation Team Meeting: Monday 10/9/23 at 10am ET; Recommendation for intended award to be posted on or about 10/10/23; Prequalification period effective 1/1/24-12/31/24; Vendors interested must possess a minimum of \$1M in current bonding capacity and \$1M in general liability and property damage insurance; Vendors interested in this project may obtain detailed information for RFQ #23-03 at https://www.bidnetdirect.com/florida/floridasouthwestern.  
 Aug. 25; Sept. 1, 8, 15, 2023 23-01719C

FOURTH INSERTION

NOTICE OF ACTION FOR FAMILY LAW CASES WITH MINOR CHILDREN IN THE CIRCUIT COURT OF THE TWENTIETH JUDICIAL CIRCUIT, IN AND FOR COLLIER COUNTY, FLORIDA  
**Case No.: 2023-DR-208**  
**Division: Domestic Relations**  
**Jorge Maldonado, Petitioner, and Marbic Montilva, Respondent.**  
 Paternity  
 TO: Marbic Montilva  
 28750 Trails Edge Blvd Bonita Springs, Florida 34134  
 YOU ARE NOTIFIED that an action for Family has been filed against you and that you are required to serve a copy of your written defenses, if any, to it on Jorge Maldonado, whose address is 754 101st Ave N Naples, Florida 34108, on or before 09/18/2023, and file the original with the clerk of this Court at Collier Court, before service on Petitioner or immediately thereafter. If you fail to do so, a default may be entered against you for the relief demanded in the petition.  
 {If applicable, insert the legal description of real property, a specific description of personal property, and the name of the county in Florida where the property is located} None.  
 Copies of all court documents in this case, including orders, are available at the Clerk of the Circuit Court's office. You may review these documents upon request.  
 You must keep the Clerk of the Circuit Court's office notified of your current address. (You may file Designation of Current Mailing and E-Mail Address, Florida Supreme Court Approved Family Law Form 12.915.) Future papers in this lawsuit will be mailed or e-mailed to the addresses on record at the clerk's office.  
 WARNING: Rule 12.285, Florida Family Law Rules of Procedure, requires certain automatic disclosure of documents and information. Failure to comply can result in sanctions, including dismissal or striking of pleadings.  
 Dated: 8/17/2023.  
 CLERK OF THE CIRCUIT COURT (Seal) By: Yliana Mirabal  
 Aug. 25; Sept. 1, 8, 15, 2023 23-01750C

SECOND INSERTION

NOTICE TO CREDITORS IN THE CIRCUIT COURT OF THE TWENTIETH JUDICIAL CIRCUIT IN AND FOR COLLIER COUNTY, FLORIDA  
**File No. 2023-CP-2485**  
**Division: Probate**  
**IN RE: ESTATE OF SUSAN DIMAIO Deceased.**  
 The administration of the estate of Susan DiMaio, deceased, whose date of death was July 13, 2023, is pending in the Circuit Court for Collier County, Florida, Probate Division, the address of which is 3315 Tamiami Trail East, Ste. 102, Naples, FL 34112. The names and addresses of the personal representatives and the personal representative's attorney are set forth below.  
 All creditors of the decedent and other persons having claims or demands against decedent's estate, on whom a copy of this notice is required to be served, must file their claims with this court ON OR BEFORE THE LATER OF 3 MONTHS AFTER THE TIME OF THE FIRST PUBLICATION OF THIS NOTICE OR 30 DAYS AFTER THE DATE OF SERVICE OF A COPY OF THIS NOTICE ON THEM.  
 ALL CLAIMS NOT FILED WITHIN THE TIME PERIODS SET FORTH IN FLORIDA STATUTES SECTION 733.702 WILL BE FOREVER BARRED.  
 NOTWITHSTANDING THE TIME PERIOD SET FORTH ABOVE, ANY CLAIM FILED TWO (2) YEARS OR MORE AFTER THE DECEDENT'S DATE OF DEATH IS BARRED.  
 The date of first publication of this notice is: September 8, 2023.  
**ROSEANN McFERNAN**  
**Personal Representative**  
 ADAM M. GROSS  
 Florida Bar No. 114922  
 E-mail: agross@crewlawfl.com  
 Attorney for Personal Representative  
 CREW LAW, P.A.  
 1333 3rd Ave. S., Suite 505  
 Naples, FL 34102  
 Telephone: 239-790-8133  
 Facsimile: 239-230-2078  
 September 8, 15, 2023 23-01813C

SECOND INSERTION

NOTICE TO CREDITORS IN THE CIRCUIT COURT OF THE TWENTIETH JUDICIAL CIRCUIT, IN AND FOR COLLIER COUNTY, FLORIDA  
**PROBATE DIVISION**  
**Case No.: 23-CP-2503**  
**IN RE: ESTATE OF JOY LYNN BOWERS Deceased**  
 The administration of the estate of JOY LYNN BOWERS, deceased whose date of death was August 9, 2023, is pending in the Circuit Court for Collier County, Florida, Probate Division, as File No. 23-CP-2503, the address of which is 3315 Tamiami Trail E, Suite 102, Naples, FL 34112. The names and addresses of the personal representative and the personal representative's attorney are set forth below.  
 All creditors of the decedent and other persons having claims or demands against decedent's estate on whom a copy of this notice is required to be served must file their claims with this court WITHIN THE LATER OF 3 MONTHS AFTER THE TIME OF THE FIRST PUBLICATION OF THIS NOTICE OR 30 DAYS AFTER THE DATE OF SERVICE OF A COPY OF THIS NOTICE ON THEM.  
 All other creditors of the decedent and other persons having claims or demands against decedent's estate must file their claims with this court WITHIN 3 MONTHS AFTER THE DATE OF THE FIRST PUBLICATION OF THIS NOTICE. ALL CLAIMS NOT FILED WITHIN THE TIME PERIODS SET FORTH IN SECTION 733.702 OF THE FLORIDA PROBATE CODE WILL BE FOREVER BARRED. NOTWITHSTANDING THE TIME PERIODS SET FORTH ABOVE, ANY CLAIM FILED TWO (2) YEARS OR MORE AFTER THE DECEDENT'S DATE OF DEATH IS BARRED.  
 The date of first publication of this notice is September 8, 2023.  
**Personal Representative:**  
 /s/ Jason Javurek  
**Jason Javurek**  
 1890 Newport Dr. Apt. 204  
 Maple Plain, MN 55359  
 Attorney for Personal Representative:  
 /s/ Paul P. Pacchiana  
 Paul P. Pacchiana, Esq  
 Florida Bar No. 0990541  
 5621 Strand Blvd, Ste 210  
 Naples, FL 34110-7303  
 Telephone: (239) 596-0777  
 Facsimile: (239) 592-5666  
 E-mail: paul@pppfloridalaw.com  
 September 8, 15, 2023 23-01800C

**PUBLISH YOUR LEGAL NOTICE**  
 Call 941-906-9386 and select the appropriate County name from the menu.  
 or email legal@businessobserverfl.com  

SECOND INSERTION

Extra Space Storage will hold a public auction to sell personal property described below belonging to those individuals listed below at the location indicated: 8471 Davis Blvd. Naples, FL 34104 on 9/28/2023 at 10:45am.

**Tenant Name:** Bernard Lakin  
**General Description of Property:** Misc. Personal Property  
The auction will be listed and advertised on [www.storagetreasures.com](http://www.storagetreasures.com). Purchases must be made with cash only and paid at the above referenced facility in order to complete the transaction. Extra Space Storage may refuse any bid and may rescind any purchase up until the winning bidder takes possession of the personal property.  
September 8, 15, 2023 23-01805C

SECOND INSERTION

**NOTICE OF PUBLIC SALE:** THE LOCK UP SELF STORAGE at 2295 Tamiami Trail E, Naples, FL 34112 will sell the contents of the following units to satisfy a lien to the highest bidder on September 27, 2023 by 10:00 AM at WWW.STORAGETREASURES.COM. All goods must be removed from the unit within 48 hours. Unit availability subject to prior settlement of account.  
Unit 3433 Steve Jewell, Bed Frame, Flower Pot, Totes, Cleaning Supplies -  
Unit 3334 James Gill, Woodwork, Furniture, Artwork, Totes, Household Items -  
Unit 2216 Marc Darby, Clothes, Tools, Boxes, Household Items  
September 8, 15, 2023 23-01806C

SECOND INSERTION

Extra Space Storage will hold a public auction to sell personal property described below belonging to those individuals listed below at the location indicated:  
571 Airport pulling Rd N. Naples FL, 34104  
Phone: 239-643-5113  
Auction Date: 09/28/2023  
Time: 10:15am  
Frderic Noel Household items  
Belsadria Abreu Household items

The auction will be listed and advertised on [www.storagetreasures.com](http://www.storagetreasures.com). Purchases must be made with cash only and paid at the above referenced facility in order to complete the transaction. Extra Space Storage may refuse any bid and may rescind any purchase up until the winning bidder takes possession of the personal property.  
September 8, 15, 2023 23-01807C

FOURTH INSERTION

**NOTICE OF ACTION FOR FAMILY LAW CASES WITH MINOR CHILDREN**  
IN THE CIRCUIT COURT OF THE TWENTIETH JUDICIAL CIRCUIT, IN AND FOR COLLIER COUNTY, FLORIDA  
**Case No.: 2023-DR-0009-FM01-XX**  
**Division: Domestic Relations**  
**Danielle Perez, Petitioner, and Alfren Mendoza, Respondent.**  
Minor's name change  
TO: Alfren Mendoza  
201 Grassy key Ln Naples Fl 34114  
YOU ARE NOTIFIED that an action for Name change has been filed against you and that you are required to serve a copy of your written defenses, if any, to it on Danielle Perez, whose address is 201 Grassy key Ln Naples Fl 34114, on or before 9/15/2023, and file the original with the clerk of this Court at 3315 Tamiami Tr E Naples, FL 34112, before service on Petitioner or immediately thereafter. If you fail to do so, a default may be entered against you for the relief demanded in the petition.

Copies of all court documents in this case, including orders, are available at the Clerk of the Circuit Court's office. You may review these documents upon request.  
You must keep the Clerk of the Circuit Court's office notified of your current address. (You may file Designation of Current Mailing and E-Mail Address, Florida Supreme Court Approved Family Law Form 12.915.) Future papers in this lawsuit will be mailed or e-mailed to the addresses on record at the clerk's office.  
**WARNING:** Rule 12.285, Florida Family Law Rules of Procedure, requires certain automatic disclosure of documents and information. Failure to comply can result in sanctions, including dismissal or striking of pleadings.  
Dated: Aug 11 2023.  
CLERK OF THE CIRCUIT COURT (Seal) By: Barbara Ashley  
Aug. 25; Sept. 1, 8, 15, 2023  
23-01716C

SECOND INSERTION

**NOTICE TO CREDITORS TO ALL PERSONS HAVING CLAIMS OR DEMANDS AGAINST THE ABOVE ESTATE:**  
The administration of the estate of Robert Charles Brent, deceased, File Number 2023-CP-002459, is pending in the Circuit Court for Collier County, Florida, Probate Division, the address of which is 3315 Tamiami Trail E. Ste. 501, Naples, FL 34112. The names and addresses of the personal representative and that personal representative's attorney are set forth below.  
ALL INTERESTED PERSON ARE NOTIFIED THAT:  
All creditors of the decedent and other persons having claims or demands against decedent's estate on whom a copy of this notice is served within three months after the date of the first publication of this notice must file their claims with the Court WITHIN THE LATER OF THREE MONTHS AFTER THE DATE OF THE FIRST PUBLICA-

**Personal Representative**  
**Christopher Andrew Brent**  
2009 51st Street NW  
Naples, FL 34116  
Attorney for Personal Representative  
Cassidy B. Thomson, Esq  
2375 Tamiami Trail N. Ste. 208  
Naples, FL 34103  
September 8, 15, 2023 23-01823C

**NOTICE TO CREDITORS IN THE CIRCUIT COURT OF THE TWENTIETH JUDICIAL CIRCUIT IN AND FOR COLLIER COUNTY, FLORIDA**  
PROBATE DIVISION  
**File No. 2023-CP-002570**  
**IN RE: ESTATE OF ROBERT ALAN SIEVERS, Deceased.**  
The administration of the estate of ROBERT ALAN SIEVERS, deceased, whose date of death was August 12, 2023, is pending in the Circuit Court for Collier County, Florida, Probate Division, the address of which is 3315 Tamiami Trail East, Suite 102, Naples, Florida 34112. The names and addresses of the personal representative and the personal representative's attorney are set forth below.  
All creditors of the decedent and other persons having claims or demands against decedent's estate, on whom a copy of this notice is required to be served, must file their claims with this court ON OR BEFORE THE LATER OF 3 MONTHS AFTER THE TIME OF THE FIRST PUBLICATION OF THIS NOTICE OR 30 DAYS AFTER THE DATE OF SERVICE OF A COPY OF THIS NOTICE ON THEM.  
All other creditors of the decedent and other persons having claims or demands against decedent's estate on whom a copy of this notice is required to be served, must file their claims with this court ON OR BEFORE THE LATER OF 3 MONTHS AFTER THE TIME OF THE FIRST PUBLICATION OF THIS NOTICE OR 30 DAYS AFTER THE DATE OF SERVICE OF A COPY OF THIS NOTICE ON THEM.  
September 8, 15, 2023 23-01812C

SECOND INSERTION

**NOTICE TO CREDITORS IN THE CIRCUIT COURT OF THE TWENTIETH JUDICIAL CIRCUIT IN AND FOR COLLIER COUNTY, FLORIDA**  
PROBATE DIVISION  
**File No. 2023-CP-002570**  
**IN RE: ESTATE OF ROBERT ALAN SIEVERS, Deceased.**  
The administration of the estate of ROBERT ALAN SIEVERS, deceased, whose date of death was August 12, 2023, is pending in the Circuit Court for Collier County, Florida, Probate Division, the address of which is 3315 Tamiami Trail East, Suite 102, Naples, Florida 34112. The names and addresses of the personal representative and the personal representative's attorney are set forth below.  
All creditors of the decedent and other persons having claims or demands against decedent's estate, on whom a copy of this notice is required to be served, must file their claims with this court ON OR BEFORE THE LATER OF 3 MONTHS AFTER THE TIME OF THE FIRST PUBLICATION OF THIS NOTICE OR 30 DAYS AFTER THE DATE OF SERVICE OF A COPY OF THIS NOTICE ON THEM.

**Personal Representative**  
**Aaron Matthew Sievers**  
554 Saffron Drive  
Sunbury, Ohio 43074  
Lisa H. Lipman  
Attorney for Personal Representative  
Florida Bar No. 030485  
Roetzel & Andress LPA  
999 Vanderbilt Beach Road, Suite 401  
Naples, Florida 34108  
Telephone: (239) 649-6200  
Email: llipman@ralaw.com  
Secondary Email: serve.lipman@ralaw.com  
September 8, 15, 2023 23-01812C

and other persons having claims or demands against decedent's estate must file their claims with this court WITHIN 3 MONTHS AFTER THE DATE OF THE FIRST PUBLICATION OF THIS NOTICE.  
ALL CLAIMS NOT FILED WITHIN THE TIME PERIODS SET FORTH IN FLORIDA STATUTES SECTION 733.702 WILL BE FOREVER BARRED.  
NOTWITHSTANDING THE TIME PERIOD SET FORTH ABOVE, ANY CLAIM FILED TWO (2) YEARS OR MORE AFTER THE DECEDENT'S DATE OF DEATH IS BARRED.  
The date of first publication of this notice is: September 8, 2023.  
Signed on this 1st day of September.  
**AARON MATTHEW SIEVERS**  
**Personal Representative**  
554 Saffron Drive  
Sunbury, Ohio 43074  
Lisa H. Lipman  
Attorney for Personal Representative  
Florida Bar No. 030485  
Roetzel & Andress LPA  
999 Vanderbilt Beach Road, Suite 401  
Naples, Florida 34108  
Telephone: (239) 649-6200  
Email: llipman@ralaw.com  
Secondary Email: serve.lipman@ralaw.com  
September 8, 15, 2023 23-01812C

SECOND INSERTION

**NOTICE OF ACTION FOR DISSOLUTION OF MARRIAGE (NO CHILD OR FINANCIAL SUPPORT)**  
IN THE CIRCUIT COURT OF THE 20TH JUDICIAL CIRCUIT, IN AND FOR COLLIER COUNTY, FLORIDA  
**Case No.: 23 DR 1893**  
**Division: FAMILY**  
**DORKAS MIDIALA GUERRERO, Petitioner, and LEANDRO V.A. MARTINEZ, Respondent.**  
TO: LEANDRO VALENTIN AUGUSTO MARTINEZ UNKNOWN  
YOU ARE NOTIFIED that an action for dissolution of marriage has been filed against you and that you are required to serve a copy of your written defenses, if any, to it on DORKAS MIDIALA GUERRERO, whose address is 179 PELTON AVE NAPLES FL 34112 on or before 10/17/2023, and file the original with the clerk of this Court at 3315 TAMAMIAMI TRAIL EAST NAPLES FL 34112 before service on Petitioner or immediately thereafter. If you fail to do so, a default may be entered against you for the relief demanded in the petition.  
The action is asking the court to decide how the following real or personal property should be divided: NONE  
September 8, 15, 22, 29, 2023  
23-01822C

Copies of all court documents in this case, including orders, are available at the Clerk of the Circuit Court's office. You may review these documents upon request.  
You must keep the Clerk of the Circuit Court's office notified of your current address. (You may file Designation of Current Mailing and E-Mail Address, Florida Supreme Court Approved Family Law Form 12.915.) Future papers in this lawsuit will be mailed or e-mailed to the address(es) on record at the clerk's office.  
**WARNING:** Rule 12.285, Florida Family Law Rules of Procedure, requires certain automatic disclosure of documents and information. Failure to comply can result in sanctions, including dismissal or striking of pleadings.  
Dated: Sep 05 2023  
CLERK OF THE CIRCUIT COURT (Seal) By: Mark V. Pomplas  
Deputy Clerk  
IF A NONLAWYER HELPED YOU FILL OUT THIS FORM, HE/SHE MUST FILL IN THE BLANKS BELOW:  
**RAISA**  
741 EVERGLADES BLVD S  
NAPLES, FL 34117  
2395036345  
September 8, 15, 22, 29, 2023  
23-01822C

SECOND INSERTION

**NOTICE TO CREDITORS IN THE CIRCUIT COURT FOR COLLIER COUNTY, FLORIDA**  
PROBATE DIVISION  
**File No. 23-CP-2143**  
**Division PROBATE**  
**IN RE: ESTATE OF JEAN M. MCMULLEN Deceased.**  
The administration of the estate of JEAN M. MCMULLEN, deceased, whose date of death was June 17, 2023, is pending in the Circuit Court for Collier County, Florida, Probate Division, the address of which is 3315 Tamiami Trail East, Unit 102, Naples, Florida, 34112. The names and addresses of the Co-Personal Representatives and the Co-Personal Representatives' attorney are set forth below.  
All creditors of the decedent and other persons having claims or demands against decedent's estate on whom a copy of this notice is required to be served must file their claims with this court ON OR BEFORE THE LATER OF 3 MONTHS AFTER THE TIME OF THE FIRST PUBLICATION OF THIS NOTICE OR 30 DAYS AFTER THE DATE OF SERVICE OF A COPY OF THIS NOTICE ON THEM.  
All other creditors of the decedent and other persons having claims or demands against decedent's estate must file their claims with this court WITH-

IN 3 MONTHS AFTER THE DATE OF THE FIRST PUBLICATION OF THIS NOTICE.  
ALL CLAIMS NOT FILED WITHIN THE TIME PERIODS SET FORTH IN FLORIDA STATUTES SECTION 733.702 WILL BE FOREVER BARRED.  
NOTWITHSTANDING THE TIME PERIODS SET FORTH ABOVE, ANY CLAIM FILED TWO (2) YEARS OR MORE AFTER THE DECEDENT'S DATE OF DEATH IS BARRED.  
The date of first publication of this notice is September 8, 2023.  
**Co-Personal Representatives:**  
**BARBARA J. MCMULLEN**  
9524 Red Run Drive  
Tampa, Florida 33635  
**SUSAN DONOLO**  
20B Bobolink Court  
Naples, Florida 34105  
Attorney for Co-Personal Representatives:  
Conrad Willkomm, Esq.  
Florida Bar Number: 697338  
Law Office of Conrad Willkomm, P.A.  
3201 Tamiami Trail North,  
Second Floor  
Naples, Florida 34103  
Telephone: (239) 262-5303  
Fax: (239) 262-6030  
E-Mail: conrad@swfloridalaw.com  
Secondary E-Mail: kara@swfloridalaw.com  
September 8, 15, 2023 23-01811C

SECOND INSERTION

**NOTICE TO CREDITORS IN THE CIRCUIT COURT FOR COLLIER COUNTY, FLORIDA**  
PROBATE DIVISION  
**Case No. 2023 CP 002557**  
**Division: Judge Foster**  
**IN RE: ESTATE OF ALYCE V. TEDESCO Deceased.**

The administration of the Estate of Alyce V. Tedesco, deceased, whose date of death was August 5, 2023, is pending in the Circuit Court for Collier County, Florida, Probate Division, the address of which is 3315 Tamiami Trail E., Ste. 102, Naples, FL 34112. The names and addresses of the Personal Representatives and of the Personal Representatives' attorney are set forth below.  
All creditors of the Decedent and other persons having claims or demands against the Decedent's Estate on whom a copy of this notice is re-

quired to be served must file their claims with this court ON OR BEFORE THE LATER OF 3 MONTHS AFTER THE TIME OF THE FIRST PUBLICATION OF THIS NOTICE OR 30 DAYS AFTER THE DATE OF SERVICE OF A COPY OF THIS NOTICE ON THEM.  
All other creditors of the Decedent and other persons having claims or demands against the Decedent's Estate must file their claims with this court WITHIN 3 MONTHS AFTER THE DATE OF THE FIRST PUBLICATION OF THIS NOTICE.  
ALL CLAIMS NOT FILED WITHIN THE TIME PERIODS SET FORTH IN FLORIDA STATUTES SECTION 733.702 WILL BE FOREVER BARRED.  
NOTWITHSTANDING THE TIME PERIODS SET FORTH ABOVE, ANY CLAIM FILED TWO (2) YEARS OR MORE AFTER DECEDENT'S DATE

OF DEATH IS BARRED.  
The date of the first publication of this Notice is September 8, 2023.  
**Personal Representatives:**  
/s/ Mark Tedesco  
**Mark Tedesco**  
145 Hard Rock Road  
Watertown, CT 06795  
/s/ Todd Tedesco  
**Todd Tedesco**  
851 Scott Drive  
Marco Island, FL 34145  
Attorney for  
Personal Representatives:  
/s/ Noel T. Langerman  
Noel T. Langerman, Esq.  
Florida Bar No. 88866  
Karp & Langerman, P.C.  
185 Plains Road, Suite 209  
Milford, CT 06461  
Telephone: (203) 876-0606  
E-mail:  
nlangerman@karp-langerman.com  
September 8, 15, 2023 23-01819C

SECOND INSERTION

**NOTICE TO CREDITORS IN THE CIRCUIT COURT OF THE TWENTIETH JUDICIAL CIRCUIT IN AND FOR COLLIER COUNTY, FLORIDA**  
PROBATE DIVISION  
**CASE NO. 23-CP-2455**  
**IN RE: ESTATE OF NANCY M. SCHERER, Deceased.**  
The administration of the estate of NANCY M. SCHERER, deceased, whose date of death was June 26, 2023, is pending in the Circuit Court for Collier County, Florida, Probate Division, the address of which is 3315 Tamiami Trail East, Suite 102, Naples, FL 34112. The names and addresses of the personal representative and the personal representative's attorney are set forth below.  
All creditors of the decedent and other persons having claims or demands against decedent's estate on whom a

copy of this notice is required to be served must file their claims with this court ON OR BEFORE THE LATER OF 3 MONTHS AFTER THE TIME OF THE FIRST PUBLICATION OF THIS NOTICE OR 30 DAYS AFTER THE DATE OF SERVICE OF A COPY OF THIS NOTICE ON THEM.  
All other creditors of the decedent and other persons having claims or demands against decedent's estate must file their claims with this court WITHIN 3 MONTHS AFTER THE DATE OF THE FIRST PUBLICATION OF THIS NOTICE.  
ALL CLAIMS NOT FILED WITHIN THE TIME PERIODS SET FORTH IN FLORIDA STATUTES SECTION 733.702 WILL BE FOREVER BARRED.  
NOTWITHSTANDING THE TIME PERIODS SET FORTH ABOVE, ANY CLAIM FILED TWO (2) YEARS OR MORE AFTER THE DECEDENT'S

DATE OF DEATH IS BARRED.  
The date of first publication of this notice is September 8, 2023.  
**HUBERT P. SCHERER**  
3135 70th St. SW  
Naples, Florida 34105  
**EDWARD V. SMITH**  
Florida Bar No. 102848  
Email: esmith@wga-law.com  
Alternate Email:  
pleadings@wga-law.com  
**EDWARD E. WOLLMAN**  
Florida Bar No. 0618640  
Email: ewollman@wga-law.com  
Alternate Email:  
pleadings@wga-law.com  
Attorneys for Personal Representative  
**WOLLMAN, GEHRKE & ASSOCIATES, PA**  
2235 Venetian Court, Suite 5  
Naples, FL 34109  
Telephone: 239-435-1533  
Facsimile: 239-435-1433  
September 8, 15, 2023 23-01801C

SECOND INSERTION

**NOTICE TO CREDITORS IN THE CIRCUIT COURT FOR COLLIER COUNTY, FLORIDA**  
PROBATE DIVISION  
**File No. 23-CP-2323**  
**Division Probate**  
**IN RE: ESTATE OF CARYLSUE C. AMBEL Deceased.**  
The administration of the estate of Carylsue C. Ambel, deceased, whose date of death was June 7, 2023, is pending in the Circuit Court for Collier County, Florida, Probate Division, the address of which is 3315 Tamiami Trail East, Suite 102, Naples, Florida 34112. The names and addresses of the personal representative and the personal representative's attorney are set forth below.  
All creditors of the decedent and other persons having claims or demands

against decedent's estate on whom a copy of this notice is required to be served must file their claims with this court ON OR BEFORE THE LATER OF 3 MONTHS AFTER THE TIME OF THE FIRST PUBLICATION OF THIS NOTICE OR 30 DAYS AFTER THE DATE OF SERVICE OF A COPY OF THIS NOTICE ON THEM.  
All other creditors of the decedent and other persons having claims or demands against decedent's estate must file their claims with this court WITHIN 3 MONTHS AFTER THE DATE OF THE FIRST PUBLICATION OF THIS NOTICE.  
ALL CLAIMS NOT FILED WITHIN THE TIME PERIODS SET FORTH IN FLORIDA STATUTES SECTION 733.702 WILL BE FOREVER BARRED.  
NOTWITHSTANDING THE TIME PERIODS SET FORTH ABOVE, ANY

CLAIM FILED TWO (2) YEARS OR MORE AFTER THE DECEDENT'S DATE OF DEATH IS BARRED.  
The date of first publication of this notice is September 8, 2023.  
**Personal Representative:**  
**Sarah Hecht**  
1801 Ivy Pointe Court  
Naples, Florida 34109  
Attorney for Personal Representative:  
Jennifer J. Hammond, Attorney  
Florida Bar Number: 121531  
**GREEN SCHOENFELD & KYLE LLP**  
1380 Royal Palm Square  
Fort Meyers, FL 33919  
Telephone: (239) 936-7200  
Fax: (239) 936-7997  
E-Mail:  
jenniferhammond@gskattorneys.com  
Secondary E-Mail:  
carolgani@gskattorneys.com  
00891068.DOCX/1  
September 8, 15, 2023 23-01802C

SECOND INSERTION

**NOTICE TO CREDITORS IN THE CIRCUIT COURT OF THE TWENTIETH JUDICIAL CIRCUIT, IN AND FOR COLLIER COUNTY, FLORIDA**  
PROBATE DIVISION  
**File # 2023-CP-2396**  
**IN RE: THE ESTATE OF GILDA RAIMONDI, Deceased.**  
The administration of the estate of Gilda Raimondi, deceased, File No. 2023-CP-2396 is pending in the Collier County County, Florida, Probate Division, the address of which is Collier County Clerk of Court and Comptroller, Collier County Government Complex 3315 E. Tamiami Trail N. 34112. The names and addresses of the personal

representative and the personal representative's attorney are set forth below.  
All creditors of the decedent and other persons having claims or demands against decedent's estate, including unmatured, contingent or unliquidated claims, on whom a copy of this notice is served must file their claims with this court WITHIN THE LATER OF 3 MONTHS AFTER THE DATE OF THE FIRST PUBLICATION OF THIS NOTICE OR 30 DAYS AFTER THE DATE OF SERVICE OF A COPY OF THIS NOTICE ON THEM.  
All other creditors of the decedent and other persons having claims or demands against decedent's estate, in-

cluding unmatured, contingent or unliquidated claims, must file their claims with this court WITHIN 3 MONTHS AFTER THE DATE OF THE FIRST PUBLICATION OF THIS NOTICE.  
ALL CLAIMS NOT SO FILED WILL BE FOREVER BARRED.  
The date of first publication of this Notice is September 8, 2023.  
**Personal Representative:**  
**Amy Fagan**  
Attorney for Personal Representative:  
Brian McNamara, Esq.  
Florida Bar No. 98022  
McNamara Legal Services, P.A.  
5425 Park Central Court,  
Naples, FL 34109  
Telephone: 239-204-4767  
September 8, 15, 2023 23-01814C

SECOND INSERTION

**NOTICE OF PUBLIC SALE**  
To satisfy the owner's storage lien, PS Retail Sales, LLC will sell at public lien sale on September 26, 2023, the personal property in the below-listed units, which may include but are not limited to: household and personal items, office and other equipment. The public sale of these items will begin at 09:45 AM and continue until all units are sold. The lien sale is to be held at the online auction website, [www.storagetreasures.com](http://www.storagetreasures.com), where indicated. For online lien sales, bids will be accepted until 2 hours after the time of the sale specified.  
**PUBLIC STORAGE # 00131, 8705 Addison Place Dr, Naples, FL 34119, (239) 944-5375**  
**Time: 10:00 AM**  
**Sale to be held at [www.storagetreasures.com](http://www.storagetreasures.com).**  
1215 - martinez, Yobany; 1302 - Sierens, Luke; 1517 - Ramirez, Orlando; 1522 - lofland, Amanda; 2723 - Kolby, Donna  
**PUBLIC STORAGE # 25435, 3555 Radio Road, Naples, FL 34104, (941) 229-6127**  
**Time: 10:15 AM**  
**Sale to be held at [www.storagetreasures.com](http://www.storagetreasures.com).**  
A014 - Estrada, Alcides; A902 - Frangie, Ursela; G326 - Webb, Mark; H387 - Burr, Jeffrey  
**PUBLIC STORAGE # 25428, 15800 Old 41 North, Naples, FL 34110, (941) 212-2707**  
**Time: 10:30 AM**  
**Sale to be held at [www.storagetreasures.com](http://www.storagetreasures.com).**  
D017 - Spurgeon, Andrew; E032 - Serrano, Manuel Martinez; E039 - acik, Salih  
**PUBLIC STORAGE # 25849, 7325 Davis Blvd, Naples, FL 34104, (305) 615-1925**  
**Time: 11:45 AM**  
**Sale to be held at [www.storagetreasures.com](http://www.storagetreasures.com).**  
A1302 - Aristone, Marcel; A1452 - Renaud, William; A1482 - Williams, Charles; A3318 - Aaron, Victoria; B1102 - Reineresen, Cameron; C1123 - Reedy, Kevin; C2245 - Jackson, Brandon; C2251 - Johnson, Victoria; C2277 - Johnson, Victoria; D1149 - adams, angela; D1153 - Johnson, Victoria; D2105 - Laguerre, Susenie; D2206 - pineda, carlos; D2268 - Duran, Jay; F1342 - Douglass, Thomas; F1351 - rios, francisco; F2116 - Candido, Alessandro; F2135 - Johnson, Victoria; F2235 - Henry, James; F2259 - Roberge, Rita; F2307 - STIKES, LORI; F2332 - Anderson, John; F2338 - adams, angela; F2381 - Agustin, Marlene  
**PUBLIC STORAGE # 26659, 3807 White Lake Blvd, Naples, FL 34117, (239) 920-5315**  
**Time: 12:00 PM**  
**Sale to be held at [www.storagetreasures.com](http://www.storagetreasures.com).**  
1198 - Egwakhide, Paul; 1294 - Lopez, Elsa; 2003 - Mendoza, Jesus; 2070 - James, Quinilia; 2168 - Young, Marlos; 2173 - Mcgill, Leslie; 2189 - Sagesse, Beloussa  
Public sale terms, rules, and regulations will be made available prior to the sale. All sales are subject to cancellation. We reserve the right to refuse any bid. Payment must be in cash or credit card-no checks. Buyers must secure the units with their own personal locks. To claim tax-exempt status, original RESALE certificates for each space purchased is required. By PS Retail Sales, LLC, 701 Western Avenue, Glendale, CA 91201. (818) 244-8080.  
September 8, 15, 2023  
23-01815C

**PUBLISH YOUR LEGAL NOTICE**  
Email  
[legal@businessobserververfl.com](mailto:legal@businessobserververfl.com)  
**Business Observer**  
ISSUES NEIGHBORS FOR THE STATE  
LV2023-17

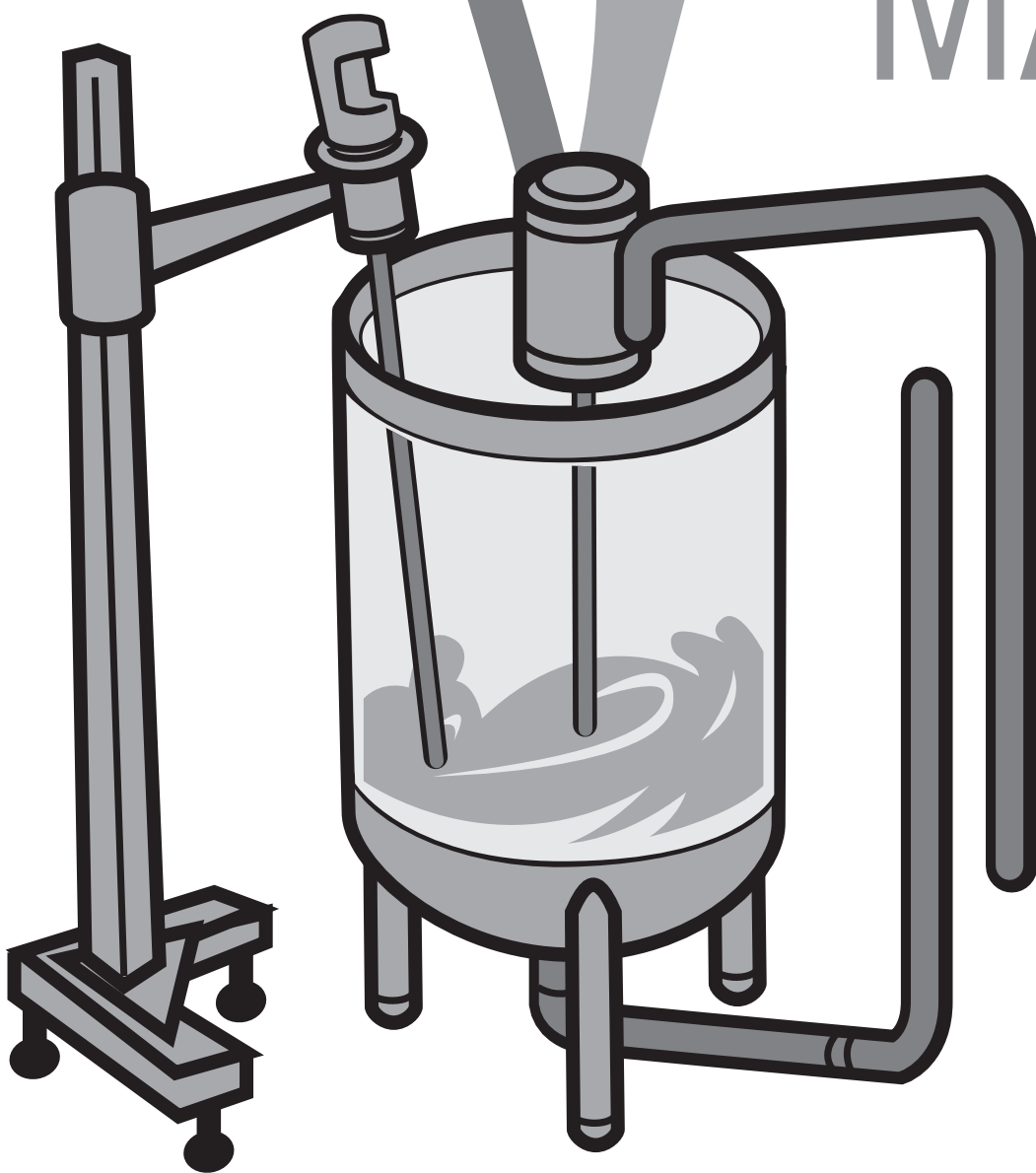
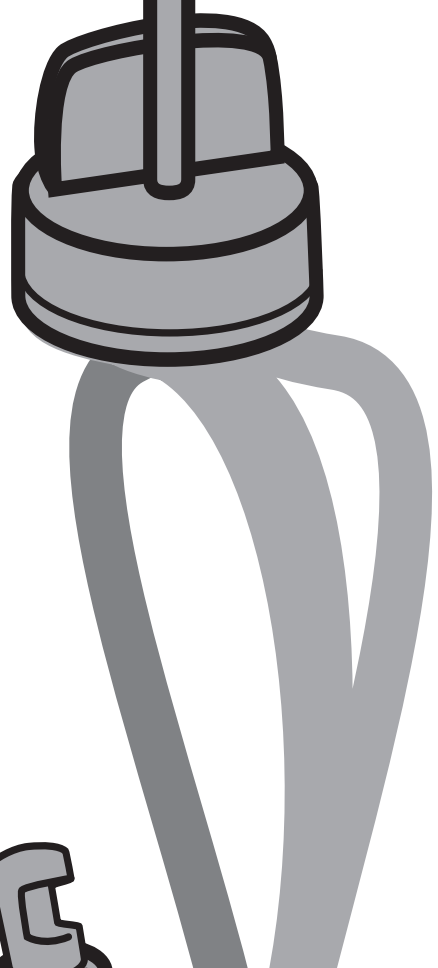
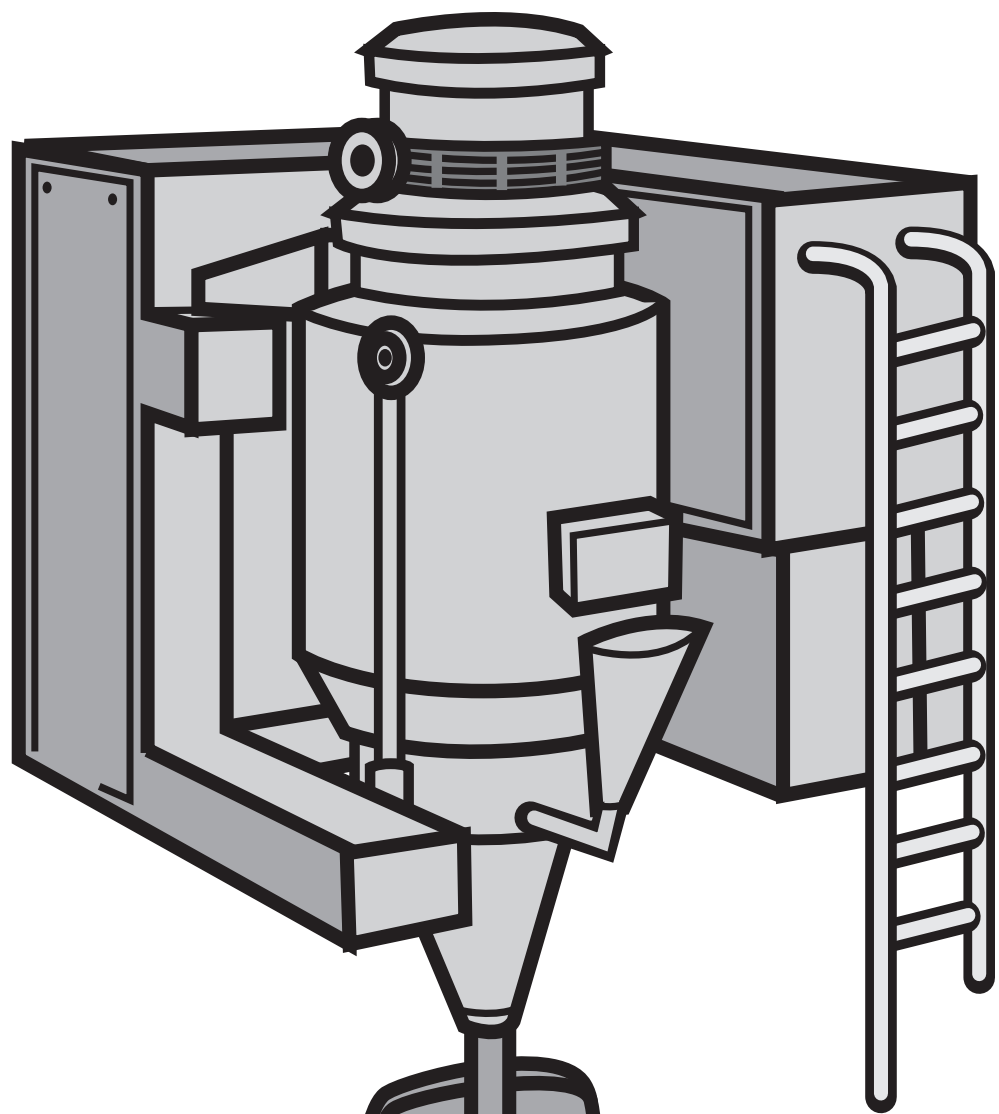

A special printing of a classic story illustrating the importance of protecting capitalism.

# TOM SMITH AND HIS INCREDIBLE BREAD MACHINE

**By R.W. Grant**

Illustrations by Austin McKinley

This is the legend of a man whose name  
Was a household word: a man whose fame  
Burst on the world like an atom bomb.  
Smith was his last name; first name: Tom.

The argument goes on today.  
"He was a villain," some will say.  
"No! A hero!" others declare.  
Or was he both? Well, I despair;  
The fight will last 'til kingdom come;  
Was Smith a hero? Or was Smith a bum?  
So, listen to the story and it's up to you  
To decide for yourself as to which is true!

Now, Smith, an inventor, had specialized  
In toys. So people were surprised  
When they found that he instead  
Of making toys, was baking bread!  
The news was flashed by CBS  
Of his incredible success.  
Then NBC jumped in in force,  
Followed by the Times, of course.  
The reason for their rapt attention,  
The nature of his new invention,  
The way to make bread he'd conceived  
Cost less than people could believe!  
And not just make it! This device  
Could in addition wrap and slice!  
The price per loaf, one loaf or many:  
The miniscule sum of under one penny!

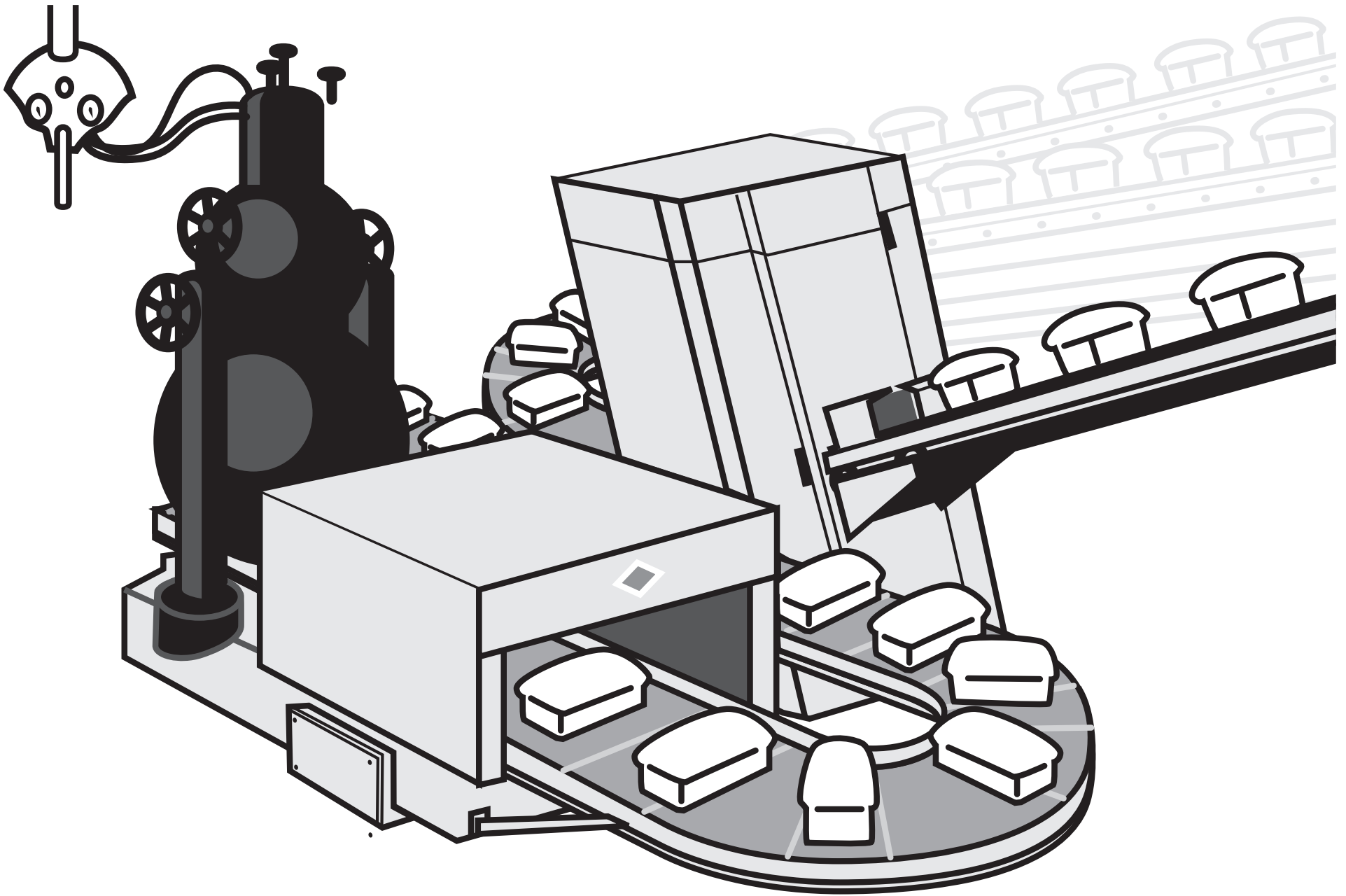

Can you imagine what this meant?  
Can you comprehend the consequent?  
The first time yet the world well fed!  
And all because of Tom Smith's bread!

Not the last to see the repercussions  
Were the Red Chinese, and, of course, the  
Russians,  
For Capitalist bread in such array

Threw the whole red block into black dis-  
may!  
Nonetheless, the world soon found  
That bread was plentiful the world  
around.  
Thanks to Smith and all that bread,  
A grateful world was at last well fed!

But isn't it a wondrous thing  
How quickly fame is flown?  
Smith, the hero of today  
Tomorrow, scarcely known!  
Yes, the fickle years passed by.  
Smith was a billionaire.

But Smith himself was now forgot,  
Though bread was everywhere.  
People, asked from where it came,  
Would very seldom know.

They would simply eat and ask,  
'Was not it always so?'

However, Smith cared not a bit,  
For millions ate his bread,  
And "Everything is fine," thought he.  
'I'm rich and they are fed!'

Everything was fine, he thought?  
He reckoned not with fate.  
Note the sequence of events  
Starting on the date  
On which inflation took its toll,  
And to a slight extent,  
The price on every loaf increased:  
It went to one full cent!

A sharp reaction quickly came.  
People were concerned.  
White House aide expressed dismay.  
Then the nation learned  
That Russia lodged a sharp protest.  
India did the same.  
"Exploitation of the Poor!"  
Yet, who was there to blame?

And though the clamor ebbed and flowed,  
All that Tom would say  
Was that it was but foolish talk.  
Which soon would die away.  
And it appeared that he was right.  
Though on and on it ran,  
The argument went 'round and 'round  
But stopped where it began.

There it stopped, and people cried,  
"For heaven's sake, we can't decide!  
It's relative! Beyond dispute,  
There's no such thing as 'absolute'!  
And though we try with all our might,  
Since nothing's ever black or white,  
All that we can finally say is  
'Everything one shade of grey is!'  
So people cried out, "Give us light!  
We can't tell what's wrong from right!"

To comprehend confusion,  
We seek wisdom at its source.  
To whom, then did the people turn?  
The Intellectuals, of course!

And what could be a better time  
For them to take the lead,  
Than at their International Conference  
On Inhumanity and Greed.  
For at this weighty conference,  
Once each year we face  
The moral conscience of the world—  
Concentrated in one place.

At that mighty conference were  
A thousand, more or less,  
Of intellectuals and bureaucrats,  
And those who write the press.  
And from Yale and Harvard  
The professors; all aware  
The fate of Smith would now be known.  
Excitement filled the air!

"The time has come," the chairman said  
"To speak of many things:  
Of duty, bread and selfishness,  
And the evil that it brings.  
For, speaking thus we can amend  
That irony of fate  
That gives to unenlightened minds  
The power to create.



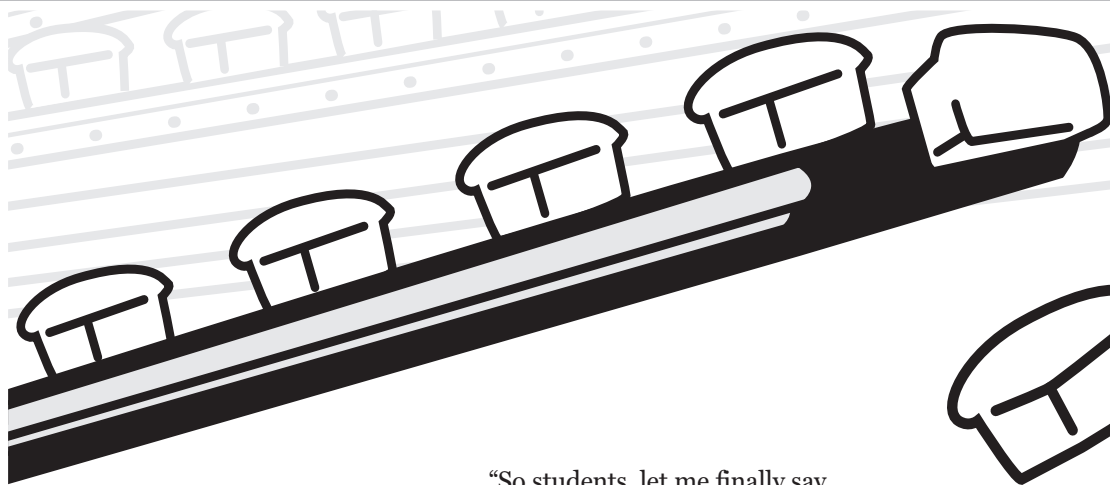

“Since reason tells us that it can’t,  
Therefore let us start  
Not by thinking with the mind,  
But only with the heart!  
Since we believe in people, then,”  
At last the chairman said,  
“We must meet our obligation  
To see that they are fed!”

And so it went, one by one,  
Denouncing private greed;  
Denouncing those who’d profit thus  
From other people’s need!

Then, suddenly each breath was held,  
For there was none more wise  
Than the nation’s foremost Pundit  
Who now rose to summarize:

“My friends,” he said, (they all  
exhaled)  
“We see in these events  
The flouting of the Higher Law—  
And its consequence.  
We must again remind ourselves  
Just why mankind is cursed:  
Because we fail to realize  
Society comes first!”

“Smith placed himself above the  
group  
To profit from his brothers.  
He failed to see the Greater Good,  
Is Service, friends, to Others!”

With boldness and with vision,  
then,  
They ratified the motion  
To dedicate to all mankind  
Smith’s bread—and their devotion!

The conference finally ended.  
It had been a huge success.  
The intellectuals had spoken.  
Now others did the rest.

The professors joined in all the  
fuss,  
And one was heard to lecture thus:  
(For clarity, he spoke in terms  
Of Mother Nature, birds and worms):

“That early birds should get the worm  
Is clearly quite unfair.  
Wouldn’t it much nicer be  
If all of them would share?  
But selfishness and private greed

Seem part of nature’s plan,  
Which Mother Nature has decreed  
For bird. But also Man?  
The system which I question now,  
As you are well aware,  
(I’m sure you’ve heard the term  
before  
Is Business, Laissez-Faire!

“So students, let me finally say  
That we must find a nobler way.  
So, let us fix the race that all  
May finish side-by-side;  
The playing field forever flat,  
The score forever tied.  
To achieve this end, of course,  
We turn to government—and force.  
So, if we have to bring Smith do  
As indeed we should,  
I’m sure you will agree with me,  
It’s for the Greater Good!”

Comments in the nation’s press  
Now scorned Smith and his plunder:  
“What right had he to get so rich  
On other people’s hunger?”  
A prize cartoon depicted Smith  
With fat and drooping jowls  
Snatching bread from hungry babes,  
Indifferent to their howls.

One night, a TV star cried out,  
“Forgive me if I stumble,  
But I don’t think, I kid you not,  
That Smith is very humble!”  
Growing bolder, he leaped up,

(Silencing the cheers)  
“Humility!” he cried to all—  
And then collapsed in tears!

The clamor rises all about;  
Now hear the politician shout:  
“What’s Smith done, so rich to be?  
Why should Smith have more than thee?  
So, down with Smith and all his greed;  
I’ll protect your right to need!”

Then Tom found to his dismay  
That certain businessmen would say,  
“The people now should realize  
It’s time to cut Smith down to size,  
For he’s betrayed his public trust  
(And taken all that bread from us!)”

Well, since the Public does come first,  
It could not be denied  
That in matters such as this,  
The public must decide.  
So, SEC became concerned,  
And told the press what it had learned:  
“It’s obvious that he’s guilty  
—Of what we’re not aware—  
Though actually and factually  
We’re sure there’s something there!”

And Antitrust now took a hand.  
Of course it was appalled  
At what it found was going on.  
The “bread trust” it was called.

“Smith has too much crust,”  
they said. “A deplorable condition  
That Robber Barons profit thus  
From cutthroat competition!”

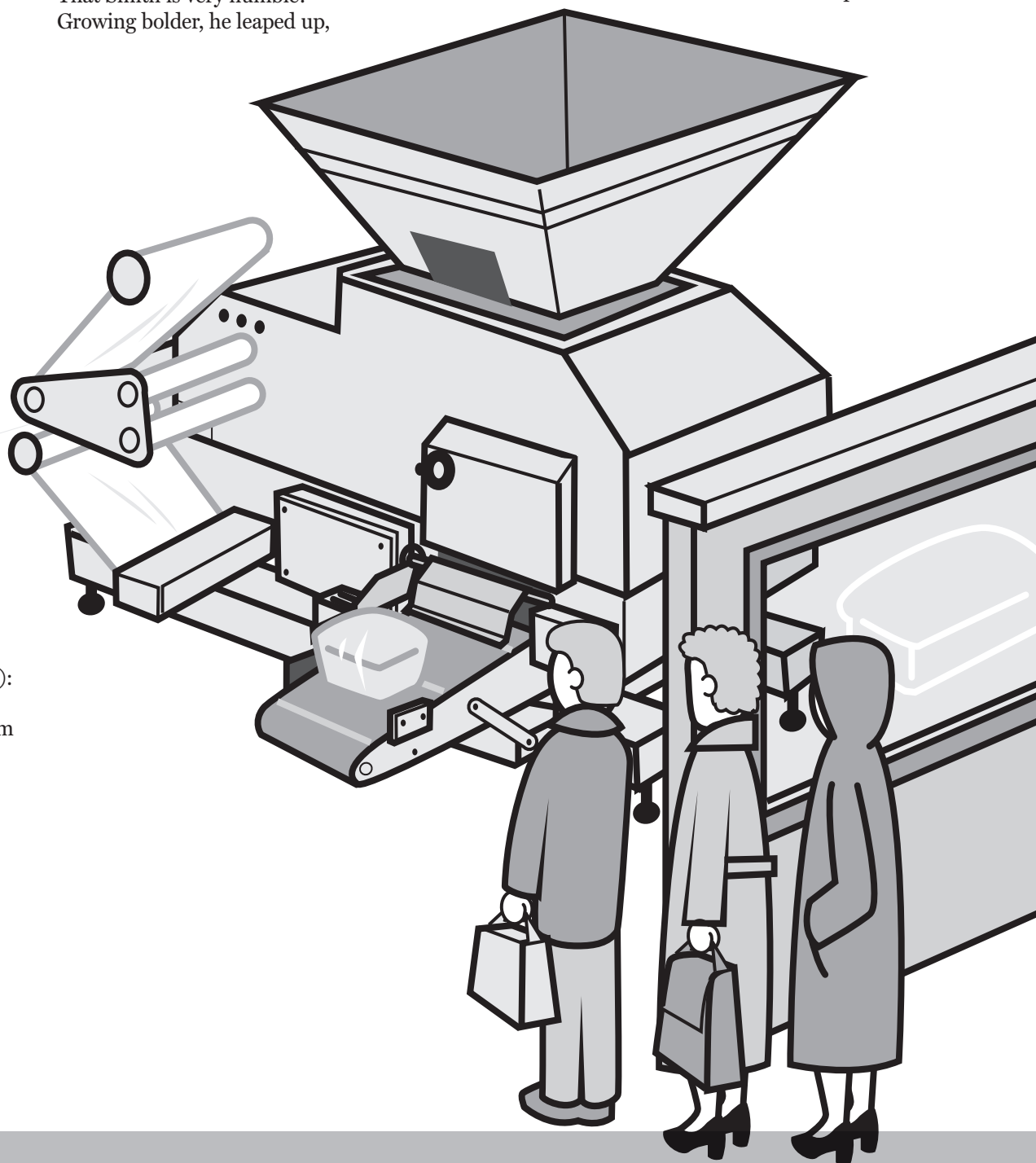

WELL!

This was getting serious!  
So Smith felt that he must  
Have a friendly interview  
With SEC and 'Trust.  
So, hat in hand, he went to them.  
They'd surely been misled;  
No rule of law had he defied.  
But then their lawyer said:

"The rule of law, in complex times,  
Has proved itself deficient.  
We much prefer the rule of men.  
It's vastly more efficient.

"So, nutshell-wise, the way it is,  
The law is what we say it is!

"So, let me state the present rules,"  
The lawyer then went on,  
"These very simple guidelines  
You can rely upon:  
You're gouging on your prices  
If you charge more than the rest.  
But it's unfair competition  
If you think you can charge less!  
"A second point that we would make,  
To help avoid confusion:  
Don't try to charge the same amount,  
For that would be collusion!"

"You must compete—but not too much.  
For if you do, you see,  
Then the market would be yours—  
And that's monopoly!  
Oh, don't dare monopolize!  
We'd raise an awful fuss,  
For that's the greatest crime of all!  
(Unless it's done by us!)"

"I think I understand," said Tom.  
"And yet, before I go,  
How does one get a job like yours?  
I'd really like to know!"

The lawyer rose then with a smile;  
"I'm glad you asked," said he.  
"I'll tell you how I got my start  
And how it came to be."

(His secretaries gathered 'round  
As their boss did thus expound.)

*"When I was a lad going off to school,  
I was always guided by this golden rule:  
Let others take the lead in things, for  
heaven's sake,  
So if things go wrong-why, then it's their  
mistake!"*  
(*So if things go wrong-why, then it's their  
mistake!*)

*"Following this precept it came to pass  
I became the president of my senior class.  
Then on to college where my profs extolled  
The very same theory from the very same  
mold!"*  
(*The very same theory from the very same  
mold!*)

*"Let others take the chances, and I would  
go along.  
Then I would let them know where they all  
went wrong!  
So successful was my system that then  
indeed,  
I was voted most likely in my class to suc-  
ceed!"*

*(He was voted most likely in his class to  
succeed!)*

*"Then out into the world I went, along  
with all the rest,  
Where I put my golden rule to the ulti-  
mate test.  
I avoided all of commerce at whatever the  
cost—  
And because I never ventured, then I also  
never lost!"*  
(*And because he never ventured, then he  
also never lost!*)

*"With this unblemished record then, I  
quickly caught the eye  
Of some influential people 'mongst the  
powers on high.*

*And so these many years among the  
mighty I have sat,  
Having found my niche as a bureaucrat!"*  
(*Having found his niche as a bureaucrat*)

*"To be a merchant prince has never been  
my goal,  
For I'm qualified to play a more impor-  
tant role:  
Since I've never failed in business, this of  
course assures  
That I'm qualified beyond dispute to now  
run yours!"*  
(*That he's qualified beyond dispute to now  
run yours!*)

"Thanks; that clears it up," said Tom.

The lawyer said, "I'm glad!  
We try to serve the public good.  
We're really not so bad!"

"Now, in disposing of this case,  
If you wish to know just how,  
Go up to the seventh floor;  
We're finalizing now!"

So, Tom went to the conference room  
Up on the seventh floor.  
He raised his hand, about to knock,  
He raised it—but no more—  
For what he overheard within  
Kept him outside the door!  
A sentence here, a sentence there—  
Every other word—  
He couldn't make it out (he hoped),  
For this is what he heard:

"Mumble, mumble, let's not fumble!  
Mumble, mumble, what's the charge?  
Grumble, grumble, he's not humble?  
Private greed? Or good of all?"

"Public Interest, Rah! Rah! Rah!  
Business, Business, Bah! Bah! Bah!"

"Say, now this now we confess  
That now this now is a mess!  
Well now, what now do we guess?  
Discharge? Which charge would be best?"

"How 'bout 'Greed and Selfishness'?  
Oh, wouldn't that be fun?  
It's vague enough to trip him up  
No matter what he's done!"

"We don't produce or build a thing!  
But before we're through,  
We allow that now we'll show Smith how  
We handle those who do!"

"We serve the public interest;  
We make up our own laws;  
Oh, golly gee, how selflessly  
We serve the public cause!"

"For we're the ones who make the rules  
At 'Trust and SEC,  
So bye and bye we'll get that guy;  
Now, what charge will it be?"

"Price too high? Or price too low?  
Now, which charge will we make?  
Well, we're not loath to charging both  
When public good's at stake!"

"But can we go one better?  
How 'bout monopoly?  
No muss, no fuss, oh clever us!  
Right-O! Let's charge all three!"

"But why stop here? We have one more!  
Insider Trading! Number four!  
We've not troubled to define  
This crime in any way so,  
This allows the courts to find  
Him guilty 'cause we say so!"

So, that was the indictment.  
Smith's trial soon began.  
It was a cause célèbre  
Which was followed' cross the land.  
In his defense Tom only said,  
"I'm rich, but all of you are fed!  
Is that bargain so unjust  
That I should now be punished thus?"

Tom fought it hard all the way.  
But it didn't help him win.  
The jury took but half an hour  
To bring this verdict in:

"Guilty! Guilty! We agree!  
He's guilty of this plunder!  
He had no right to get so rich  
On other people's hunger!"

"Five years in jail!" the judge then said.  
"You're lucky it's not worse!  
Robber Barons must be taught  
Society Comes First!  
As flies to wanton boys," he leered,  
"Are we to men like these!  
They exploit us for their sport!  
Exploit us as they please!"

The sentence seemed a bit severe,  
But mercy was extended.  
In deference to his mother's pleas,  
One year was suspended.  
And what about the Bread Machine?  
Tom Smith's little friend?  
Broken up and sold for scrap.  
Some win. Some lose. The end.

## EPILOGUE

Now, bread is baked by government.  
And as might be expected,  
Everything is well controlled—  
The public well protected.

True, loaves cost ten dollars each.  
But our leaders do their best.  
The selling price is half a cent.  
Taxes pay the rest!

