

--- PUBLIC SALES ---

FIRST INSERTION
Fictitious Name Notice
 Notice Is Hereby Given that Lee Health System, Inc., 2776 Cleveland Ave, Fort Myers, FL 33901, desiring to engage in business under the fictitious name of Southwest Florida Proton, with its principal place of business in the State of Florida in the County of Lee, intends to file an Application for Registration of Fictitious Name with the Florida Department of State.
 September 27, 2024 24-04196L

FIRST INSERTION
Fictitious Name Notice
 Notice Is Hereby Given that Lee Health System, Inc., 2776 Cleveland Ave, Fort Myers, FL 33901, desiring to engage in business under the fictitious name of The Children's Rehabilitation Center YMCA, with its principal place of business in the State of Florida in the County of Lee, intends to file an Application for Registration of Fictitious Name with the Florida Department of State.
 September 27, 2024 24-04199L

FIRST INSERTION
Fictitious Name Notice
 Notice Is Hereby Given that Lee Health System, Inc., 2776 Cleveland Ave, Fort Myers, FL 33901, desiring to engage in business under the fictitious name of The Children's Rehabilitation Center-GCHC, with its principal place of business in the State of Florida in the County of Lee, intends to file an Application for Registration of Fictitious Name with the Florida Department of State.
 September 27, 2024 24-04200L

FIRST INSERTION
Fictitious Name Notice
 Notice Is Hereby Given that Lee Health System, Inc., 2776 Cleveland Ave, Fort Myers, FL 33901, desiring to engage in business under the fictitious name of The Cottage at Cypress Cove, with its principal place of business in the State of Florida in the County of Lee, intends to file an Application for Registration of Fictitious Name with the Florida Department of State.
 September 27, 2024 24-04201L

FIRST INSERTION
Fictitious Name Notice
 Notice Is Hereby Given that Lee Health System, Inc., 2776 Cleveland Ave, Fort Myers, FL 33901, desiring to engage in business under the fictitious name of The Family Birth Suites, with its principal place of business in the State of Florida in the County of Lee, intends to file an Application for Registration of Fictitious Name with the Florida Department of State.
 September 27, 2024 24-04202L

FIRST INSERTION
Fictitious Name Notice
 Notice Is Hereby Given that Lee Health System, Inc., 2776 Cleveland Ave, Fort Myers, FL 33901, desiring to engage in business under the fictitious name of The Inn at Cypress Cove, with its principal place of business in the State of Florida in the County of Lee, intends to file an Application for Registration of Fictitious Name with the Florida Department of State.
 September 27, 2024 24-04203L

FIRST INSERTION
Fictitious Name Notice
 Notice Is Hereby Given that Lee Health System, Inc., 2776 Cleveland Ave, Fort Myers, FL 33901, desiring to engage in business under the fictitious name of The Lee Trauma Services District, with its principal place of business in the State of Florida in the County of Lee, intends to file an Application for Registration of Fictitious Name with the Florida Department of State.
 September 27, 2024 24-04204L

FIRST INSERTION
Fictitious Name Notice
 Notice Is Hereby Given that Lee Health System, Inc., 2776 Cleveland Ave, Fort Myers, FL 33901, desiring to engage in business under the fictitious name of The Lodge at Cypress Cove, with its principal place of business in the State of Florida in the County of Lee, intends to file an Application for Registration of Fictitious Name with the Florida Department of State.
 September 27, 2024 24-04205L

FIRST INSERTION
Fictitious Name Notice
 Notice Is Hereby Given that Lee Health System, Inc., 2776 Cleveland Ave, Fort Myers, FL 33901, desiring to engage in business under the fictitious name of The Oaks at Cypress Cove, with its principal place of business in the State of Florida in the County of Lee, intends to file an Application for Registration of Fictitious Name with the Florida Department of State.
 September 27, 2024 24-04207L

FIRST INSERTION
Fictitious Name Notice
 Notice Is Hereby Given that Lee Health System, Inc., 2776 Cleveland Ave, Fort Myers, FL 33901, desiring to engage in business under the fictitious name of The Sanctuary Outpatient Center, with its principal place of business in the State of Florida in the County of Lee, intends to file an Application for Registration of Fictitious Name with the Florida Department of State.
 September 27, 2024 24-04208L

FIRST INSERTION
Fictitious Name Notice
 Notice Is Hereby Given that Lee Health System, Inc., 2776 Cleveland Ave, Fort Myers, FL 33901, desiring to engage in business under the fictitious name of The Vineyards at Cypress Cove, with its principal place of business in the State of Florida in the County of Lee, intends to file an Application for Registration of Fictitious Name with the Florida Department of State.
 September 27, 2024 24-04210L

FIRST INSERTION
Fictitious Name Notice
 Notice Is Hereby Given that Lee Health System, Inc., 2776 Cleveland Ave, Fort Myers, FL 33901, desiring to engage in business under the fictitious name of The Wellness Center of Cape Coral, with its principal place of business in the State of Florida in the County of Lee, intends to file an Application for Registration of Fictitious Name with the Florida Department of State.
 September 27, 2024 24-04211L

--- ESTATE ---

FIRST INSERTION
NOTICE OF PUBLIC SALE OF PERSONAL PROPERTY
 Pursuant to the lien granted by the Florida Self-Storage Facility Act, notice is hereby given that the undersigned self-storage units will be sold at a public sale by competitive bidding, to satisfy the lien of the Lessor, with Metro Storage LLC as managing agent for Lessor, for rental and other charges due from the undersigned. The said property has been stored and is located at the respective address below. Units up for auction will be listed for public bidding on-line at www.StorageTreasures.com (Chris Rosa Auctioneer License AU 4167) beginning five days prior to the scheduled auction date and time. The terms of the sale will be by lot to the highest bidder for cash only. A 10% buyer's premium will be charged per unit. All sales are final. Metro Self Storage LLC reserves the right to withdraw any or all units, partial or entire, from the sale at any time before the sale or to refuse any bids. The property to be sold is described as "general household items" unless otherwise noted. All contents must be removed completely from the property within 48 hours or sooner or are deemed abandoned by bidder/buyer. Sale rules and regulations are available at the time of sale.
 Property includes the storage unit contents belonging to the following tenants at the following locations:
Metro Self Storage
3021 Lee Boulevard
Lehigh Acres, FL 33971
 The bidding will close on the website StorageTreasures.com and a high bidder will be selected on **10/15/2024 at 10AM**

Occupant Name	Unit	Description of Property
Lillian Armstrong Michalek	03026	Household Items
Jose T Garcia	03028	Household Items
Lillian Armstrong Michalek	03047	Household Items
Hector Hidalgo	03062	Household Items
David Roberts	04032	Household Items
India Miller	05018	Household Items
Joshua Collins	05112	Household Items

Sept. 27; Oct. 4, 2024 24-04218L

FIRST INSERTION
NOTICE UNDER FICTITIOUS NAME LAW PURSUANT TO SECTION 865.09, FLORIDA STATUTES
 NOTICE IS HEREBY GIVEN that CALL CENTER MARKETING SOLUTIONS, LLC will engage in business under the fictitious name NATION-WIDE LEGAL ASSIST, with a physical address 3543 NE 13TH AVE CAPE CORAL, FL 33909, with a mailing address 3543 NE 13TH AVE CAPE CORAL, FL 33909, and already registered the name mentioned above with the Florida Department of State, Division of Corporations.
 September 27, 2024 24-04221L

FIRST INSERTION
Notice Under Fictitious Name Law According to Florida Statute Number 865.09
 NOTICE IS HEREBY GIVEN that the undersigned, desiring to engage in business under the Fictitious Name of Casa D'Italia located at 11861 Palm Beach Blvd unit 101-102 in the City of Fort Myers, Lee County, FL 33905 intends to register the said name with the Division of Corporations of the Department of State, Tallahassee, Florida.
 Dated this 20th day of September, 2024.
 Neurophys LLC
 Sidney Ellington
 September 27, 2024 24-04216L

FIRST INSERTION
Notice Under Fictitious Name Law According to Florida Statute Number 865.09
 NOTICE IS HEREBY GIVEN that the undersigned, desiring to engage in business under the Fictitious Name of Hayloft Western Wear located at 4300 Lexington in the City of Fort Myers, Lee County, FL 33905 intends to register the said name with the Division of Corporations of the Department of State, Tallahassee, Florida.
 Dated this 19th day of September, 2024.
 Hucks Hayloft Western Wear Co
 September 27, 2024 24-04224L

FIRST INSERTION
Notice Under Fictitious Name Law According to Florida Statute Number 865.09
 NOTICE IS HEREBY GIVEN that the undersigned, desiring to engage in business under the Fictitious Name of SHEEHY located at 9990 Coconut Road, Suite 313 in the City of Bonita Springs, Lee County, FL 34135 intends to register the said name with the Division of Corporations of the Department of State, Tallahassee, Florida.
 Dated this 19th day of September, 2024.
 SHEEHY Holdings, LLC
 September 27, 2024 24-04223L

FIRST INSERTION
Notice Under Fictitious Name Law Pursuant to Section 865.09, Florida Statutes
 NOTICE IS HEREBY GIVEN that the undersigned, desiring to engage in business under the fictitious name of Rescue Cleaning Service located at 3701 12th St SW, in the County of Lee, in the City of Lehigh Acres, Florida 33976 intends to register the said name with the Division of Corporations of the Florida Department of State, Tallahassee, Florida.
 Dated at Lehigh Acres, Florida, this 23rd day of September, 2024.
 GKP WJL CONSULTING LLC
 September 27, 2024 24-04254L

FIRST INSERTION
Notice Under Fictitious Name Law According to Florida Statute Number 865.09
 NOTICE IS HEREBY GIVEN that the undersigned, desiring to engage in business under the Fictitious Name of RUSH INN BAR & GRILLE located at 10801 CORKSCREW RD #428 in the City of ESTERO, Lee County, FL 33928 intends to register the said name with the Division of Corporations of the Department of State, Tallahassee, Florida.
 Dated this 23rd day of September, 2024.
 RUSH INN ESTERO LLC
 KENNETH RUSH
 September 27, 2024 24-04264L

FIRST INSERTION
Fictitious Name Notice
 Notice is hereby given that EBETEC School Center Fort Myers LLC, desiring to engage in business under the fictitious name of EBETEC Language Academy Fort Myers located at 7806 College Parkway, Fort Myers, FL 33907, intends to register the said name in (Lee County) county with the Division of Corporations, Florida Department of State, pursuant to section 865.09 of the Florida Statutes.
 September 27, 2024 24-04222L

FIRST INSERTION
NOTICE OF PUBLIC SALE
 Notice is hereby given that on 10/11/2024 at 10:30 am, the following mobile home will be sold at public auction pursuant to F.S. 715.109. 1986 STE HS 36124563 . Last Tenants: PATRICIA SHERIDAN, PATRICIA MARY SHERIDAN and all unknown parties beneficiaries heirs . Sale to be at SUN INDIAN CREEK LLC, 17820 SAN CARLOS BOULEVARD, FORT MYERS, FL 33931. 813-241-8269.
 Sept. 27; Oct. 4, 2024 24-04268L

FIRST INSERTION
NOTICE OF PUBLIC SALE:
 Elsie Title Services of SW FL, LLC - agent, will sell listed unit(s) to highest bidder free of any liens; Net deposited with clerk of court per 713.585; Pauls Transmission gives Notice of Foreclosure of Lien and intent to sell these vehicles at 1302 N Tamiami TRL, N FT Myers, FL 33903 pursuant to subsection 713.585 of the Florida Statutes. Pauls Transmission reserves the right to accept or reject any and/or all bids on- 10/30/2024 09:00 AM IFMCU0GX4FUC74464 2015 FORD ESCAPE SE - on 10/31/2024 09:00 AM 1FT8W3DT5LED29890 2020 FORD F350 SUPER DUTY
 September 27, 2024 24-04253L

FIRST INSERTION
NOTICE OF PUBLIC SALE
 The following personal property of LUDMILA-JOSEPHI MILKEN and ALEX MILKIN will, on October 9, 2024, at 10:00 a.m., at 276 Valencia Drive, Lot #276, Fort Myers, Lee County, Florida 33905; be sold for cash to satisfy storage fees in accordance with Florida Statutes, Section 715.109:
 1974 SUNH MOBILE HOME, VIN: 472421343440A, TITLE NO.: 0013936851, and VIN: 472421343440, TITLE NO.: 0013936852 and all other personal property located therein
 PREPARED BY: J. Matthew Bobo
 Lutz, Bobo & Telfair, P.A.
 2 North Tamiami Trail, Suite 500
 Sarasota, Florida 34236
 (PO#25715-20)
 Sept. 27; Oct. 4, 2024 24-04258L

FIRST INSERTION
PUBLIC SALE
 Extra Space Storage will hold a public auction to sell personal property described below belonging to those individuals listed below at the location indicated: 12750 Trade Center Dr Bonita Springs, FL 34135. October 17th, 2024 at 11:45AM.
 Amy Allen
 Cabinet, bed frame, school desk, chairs, Christmas decorations, wardrobe, yoga mat
 The auction will be listed and advertised on www.storage treasures.com. Purchases must be made with cash only and paid at the above referenced facility in order to complete the transaction. Extra Space Storage may refuse any bid and may rescind any purchase up until the winning bidder takes possession of the personal property.
 Sept. 27; Oct. 4, 2024 24-04219L

FIRST INSERTION
NOTICE UNDER FICTITIOUS NAME LAW PURSUANT TO SECTION 865.09, FLORIDA STATUTES
 NOTICE IS HEREBY GIVEN that Daniel Fuchsbrugger will engage in business under the fictitious name BACIO DOLCE, with a physical address 844 SW 37th Street Cape Coral, FL 33914, with a mailing address 844 SW 37th Street Cape Coral, FL 33914, and already registered the name mentioned above with the Florida Department of State, Division of Corporations.
 September 27, 2024 24-04259L

FIRST INSERTION
Notice Under Fictitious Name Law According to Florida Statute Number 865.09
 NOTICE IS HEREBY GIVEN that the undersigned, desiring to engage in business under the Fictitious Name of Soccer Stars of Fort Myers to Naples located at 20358 Fair Oak Lane in the City of Estero, Lee County, FL 33928 intends to register the said name with the Division of Corporations of the Department of State, Tallahassee, Florida.
 Dated this 23rd day of September, 2024.
 Ryan Kaplan
 September 27, 2024 24-04263L

FIRST INSERTION
Notice of Self Storage Sale
 Please take notice Hide-Away Storage - College Parkway located at 12859 McGregor Blvd., Fort Myers, FL 33919 intends to hold a sale to sell the property stored at the Facility by the below Occupants whom are in default at an Auction. The sale will occur as an online auction via www.storage treasures.com on 10/16/2024 at 10:00AM. Unless stated otherwise the description of the contents are household goods, furnishings and garage essentials. Stephanie A Kolenut unit #00448; Andrea E Godinz unit #02120; Bryan R Bauer unit #03241; Rick Price unit #03248; Mary Snyder unit #05276. All property is being stored at the above self-storage facility. This sale may be withdrawn at any time without notice. Certain terms and conditions apply. See manager for details.
 Sept. 27; Oct. 4, 2024 24-04217L

FIRST INSERTION
NOTICE TO CREDITORS
 IN THE CIRCUIT COURT FOR LEE COUNTY, FLORIDA PROBATE DIVISION
File No. 24-CP-2784
Division: Probate
IN RE: ESTATE OF THOMAS T. ROTHMAN
 The administration of the estate of Thomas T. Rothman, deceased, whose date of death was June 16, 2024, is pending in the Circuit Court for Lee County, Florida, Probate Division, the address of which is P.O. Box 9346, Fort Myers, FL 33902. The names and addresses of the personal representatives and the personal representatives' attorney are set forth below.
 All creditors of the decedent and other persons having claims or demands against decedent's estate on whom a copy of this notice is required to be served must file their claims with this court ON OR BEFORE THE LATER OF 3 MONTHS AFTER THE TIME OF THE FIRST PUBLICATION OF THIS NOTICE OR 30 DAYS AFTER THE DATE OF SERVICE OF A COPY OF THIS NOTICE ON THEM.
 The personal representative has no duty to discover whether any property held at the time of the decedent's death by the decedent or the decedent's surviving spouse is property to which the Florida Uniform Disposition of Community Property Rights at Death Act as described in ss. 732.216-732.228, Florida Statutes, applies, or may apply, unless a written demand is made by a creditor as specified under s. 732.2211, Florida Statutes.
 All other creditors of the decedent and other persons having claims or demands against decedent's estate must file their claims with this court WITHIN 3 MONTHS AFTER THE DATE OF THE FIRST PUBLICATION OF THIS NOTICE.
 NOTWITHSTANDING THE TIME PERIODS SET FORTH ABOVE, ANY CLAIM FILED TWO (2) YEARS OR MORE AFTER THE DECEDENT'S DATE OF DEATH IS BARRED.
 The date of first publication of this notice is September 27, 2024.
Personal Representative:
Ann Raymond Webb
PO Box 1177
 250 West Simpson Lane
 Kamas, Utah 84036
 Attorney for Personal Representative:
 Janet M. Strickland,
 FL Bar No. 137472
 Law Office of Janet M. Strickland, P.A.
 2340 Periwinkle Way,
 Suite J-1
 Sanibel, FL 33957
 Telephone: (239) 472-3322
 E-Mail: jms@sanibellaw.net
 Secondary E-Mail:
 jms3@sanibellaw.net
 Sept. 27; Oct. 4, 2024 24-04225L

FIRST INSERTION
NOTICE TO CREDITORS
 IN THE CIRCUIT COURT FOR LEE COUNTY, FLORIDA PROBATE DIVISION
File No. 24-CP-2784
Division: Probate
IN RE: ESTATE OF THOMAS T. ROTHMAN
 The administration of the estate of Thomas T. Rothman, deceased, whose date of death was June 16, 2024, is pending in the Circuit Court for Lee County, Florida, Probate Division, the address of which is P.O. Box 9346, Fort Myers, FL 33902. The names and addresses of the personal representatives and the personal representatives' attorney are set forth below.
 All creditors of the decedent and other persons having claims or demands against decedent's estate on whom a copy of this notice is required to be served must file their claims with this court ON OR BEFORE THE LATER OF 3 MONTHS AFTER THE TIME OF THE FIRST PUBLICATION OF THIS NOTICE OR 30 DAYS AFTER THE DATE OF SERVICE OF A COPY OF THIS NOTICE ON THEM.
 The personal representative has no duty to discover whether any property held at the time of the decedent's death by the decedent or the decedent's surviving spouse is property to which the Florida Uniform Disposition of Community Property Rights at Death Act as described in ss. 732.216-732.228, Florida Statutes, applies, or may apply, unless a written demand is made by a creditor as specified under s. 732.2211, Florida Statutes.
 All other creditors of the decedent and other persons having claims or demands against decedent's estate must file their claims with this court WITHIN 3 MONTHS AFTER THE DATE OF THE FIRST PUBLICATION OF THIS NOTICE.
 NOTWITHSTANDING THE TIME PERIODS SET FORTH ABOVE, ANY CLAIM FILED TWO (2) YEARS OR MORE AFTER THE DECEDENT'S DATE OF DEATH IS BARRED.
 The date of first publication of this notice is September 27, 2024.
Personal Representatives:
Michael Tyler Rothman
 513 Gregg Drive
 Lilburn, Georgia 30047
Kelly Ann Rothman
 16025 266th Ave. SE
 Issaquah, WA 98027
 Attorney for Personal Representatives:
 Hayley E. Donaldson, Attorney
 Florida Bar Number: 1002236
 Sheppard Law Firm
 9100 College Pointe Court
 Fort Myers, FL 33919
 Telephone: (239) 334-1141
 Fax: (239) 334-3965
 E-Mail: donaldson@sbslaw.com
 Secondary E-Mail:
 athompson@sbslaw.com
 Sept. 27; Oct. 4, 2024 24-04226L

FIRST INSERTION
NOTICE TO CREDITORS
 IN THE CIRCUIT COURT FOR LEE COUNTY, FLORIDA PROBATE DIVISION
File No. 24-CP-2388
IN RE: ESTATE OF ALBERT HARRISON EWING, JR. Deceased.
 The administration of the estate of Albert Harrison Ewing, Jr., deceased, whose date of death was June 25, 2024, is pending in the Circuit Court for Lee County, Florida, Probate Division, the address of which is P.O. Box 9346 Fort Myers, Florida 33902. The names and addresses of the personal representative and the personal representative's attorney are set forth below.
 All creditors of the decedent and other persons having claims or demands against decedent's estate on whom a copy of this notice is required to be served must file their claims with this court ON OR BEFORE THE LATER OF 3 MONTHS AFTER THE TIME OF THE FIRST PUBLICATION OF THIS NOTICE OR 30 DAYS AFTER THE DATE OF SERVICE OF A COPY OF THIS NOTICE ON THEM.
 All other creditors of the decedent and other persons having claims or demands against decedent's estate must file their claims with this court WITHIN 3 MONTHS AFTER THE DATE OF THE FIRST PUBLICATION OF THIS NOTICE.
 ALL CLAIMS NOT FILED WITHIN THE TIME PERIODS SET FORTH IN FLORIDA STATUTES SECTION 733.702 WILL BE FOREVER BARRED.
 NOTWITHSTANDING THE TIME PERIODS SET FORTH ABOVE, ANY CLAIM FILED TWO (2) YEARS OR MORE AFTER THE DECEDENT'S DATE OF DEATH IS BARRED.
 A personal representative or curator has no duty to discover whether any property held at the time of the decedent's death by the decedent or the decedent's surviving spouse is property to which the Florida Uniform Disposition of Community Property Rights at Death Act as described in sections 732.216-732.228, applies, or may apply, unless a written demand is made by a creditor as specified under section 732.2211.
 The date of first publication of this notice is September 27, 2024.
Personal Representative:
Ann Raymond Webb
PO Box 1177
 250 West Simpson Lane
 Kamas, Utah 84036
 Attorney for Personal Representative:
 Janet M. Strickland,
 FL Bar No. 137472
 Law Office of Janet M. Strickland, P.A.
 2340 Periwinkle Way,
 Suite J-1
 Sanibel, FL 33957
 Telephone: (239) 472-3322
 E-Mail: jms@sanibellaw.net
 Secondary E-Mail:
 jms3@sanibellaw.net
 Sept. 27; Oct. 4, 2024 24-04225L

FIRST INSERTION
NOTICE TO CREDITORS
 IN THE CIRCUIT COURT FOR LEE COUNTY, FLORIDA PROBATE DIVISION
File No. 24-CP-2666
IN RE: ESTATE OF LEA SA MAGALHAES CASSES a/k/a LEA M. CASSES a/k/a LEA MAGALHAES CASSES Deceased.
 The administration of the Estate of Lea Sa Magalhaes Casse a/k/a Lea M. Casse a/k/a Lea Magalhaes Casse, deceased, File Number 24 CP 2666, is pending in the Circuit Court for Lee County, Florida, Probate Division, the address of which is 1700 Monroe Street, Fort Myers, FL 33901. The names and addresses of the personal representative and the personal representative's attorney are set forth below.
 All creditors of the Decedent and other persons having claims or demands against Decedent's estate, on whom a copy of this notice is required to be served, must file their claims with this court WITHIN THE LATER OF 3 MONTHS AFTER THE TIME OF THE FIRST PUBLICATION OF THIS NOTICE OR 30 DAYS AFTER THE DATE OF SERVICE OF A COPY OF THIS NOTICE ON THEM.
 All other creditors of the Decedent and other persons having claims or demands against Decedent's estate must file their claims with this court WITHIN 3 MONTHS AFTER THE DATE OF THE FIRST PUBLICATION OF THIS NOTICE.
 ALL CLAIMS NOT FILED WITHIN THE TIME PERIODS SET FORTH IN SECTION 33.702 OF THE FLORIDA PROBATE CODE WILL BE FOREVER BARRED.
 NOTWITHSTANDING THE TIME PERIOD SET FORTH ABOVE, ANY CLAIM FILED TWO (2) YEARS OR MORE AFTER THE DECEDENT'S DATE OF DEATH IS BARRED.
 A Personal Representative or Curator has no duty to discover whether any property held at the time of the Decedent's death by the Decedent or the Decedent's surviving spouse is property to which the Florida Uniform Disposition of Community Property Rights at Death Act as described in ss. 732.216-732.228 applies, or may apply, unless a written demand is made by a Creditor, as specified under s. 732.2211.
 The date of first publication of this Notice is September 27, 2024.
Personal Representative:
Jeffrey Lynn Casse
 701 Wood Valley Road SW
 Mableton, GA 30126
 Attorney for Personal Representative:
 Nathan Dougherty, Esquire
 Florida Bar No. 118632
 P.O. Box 380984
 Murdock, FL 33938
 Tel: (941) 270-4489
 Email:
 contact@nathandoughertylaw.com
 Sept. 27; Oct. 4, 2024 24-04228L

FIRST INSERTION
NOTICE TO CREDITORS
 IN THE CIRCUIT COURT FOR LEE COUNTY, FLORIDA PROBATE DIVISION
File No. 24-CP-2666
IN RE: ESTATE OF LEA SA MAGALHAES CASSES a/k/a LEA M. CASSES a/k/a LEA MAGALHAES CASSES Deceased.
 The administration of the Estate of Lea Sa Magalhaes Casse a/k/a Lea M. Casse a/k/a Lea Magalhaes Casse, deceased, File Number 24 CP 2666, is pending in the Circuit Court for Lee County, Florida, Probate Division, the address of which is 1700 Monroe Street, Fort Myers, FL 33901. The names and addresses of the personal representative and the personal representative's attorney are set forth below.
 All creditors of the Decedent and other persons having claims or demands against Decedent's estate, on whom a copy of this notice is required to be served, must file their claims with this court WITHIN THE LATER OF 3 MONTHS AFTER THE TIME OF THE FIRST PUBLICATION OF THIS NOTICE OR 30 DAYS AFTER THE DATE OF SERVICE OF A COPY OF THIS NOTICE ON THEM.
 All other creditors of the Decedent and other persons having claims or demands against Decedent's estate must file their claims with this court WITHIN 3 MONTHS AFTER THE DATE OF THE FIRST PUBLICATION OF THIS NOTICE.
 ALL CLAIMS NOT FILED WITHIN THE TIME PERIODS SET FORTH IN SECTION 33.702 OF THE FLORIDA PROBATE CODE WILL BE FOREVER BARRED.
 NOTWITHSTANDING THE TIME PERIOD SET FORTH ABOVE, ANY CLAIM FILED TWO (2) YEARS OR MORE AFTER THE DECEDENT'S DATE OF DEATH IS BARRED.
 A Personal Representative or Curator has no duty to discover whether any property held at the time of the Decedent's death by the Decedent or the Decedent's surviving spouse is property to which the Florida Uniform Disposition of Community Property Rights at Death Act as described in ss. 732.216-732.228 applies, or may apply, unless a written demand is made by a Creditor, as specified under s. 732.2211.
 The date of first publication of this Notice is September 27, 2024.
Personal Representative:
Jeffrey Lynn Casse
 701 Wood Valley Road SW
 Mableton, GA 30126
 Attorney for Personal Representative:
 Nathan Dougherty, Esquire
 Florida Bar No. 118632
 P.O. Box 380984
 Murdock, FL 33938
 Tel: (941) 270-4489
 Email:
 contact@nathandoughertylaw.com
 Sept. 27; Oct. 4, 2024 24-04228L

SAVE TIME

Email your Legal Notice
 legal@businessobserverfl.com
 Deadline Wednesday at noon • Friday Publication

SARASOTA • MANATEE
 HILLSBOROUGH • PASCO
 PINELLAS • POLK • LEE
 COLLIER • CHARLOTTE

Business Observer
 FLORIDA'S NEWSPAPER FOR THE C-SUITE
 LV20906-V12

--- TAX DEEDS ---

FIRST INSERTION
NOTICE OF APPLICATION FOR TAX DEED
Section 197.512 F.S.
Tax Deed #:2024000894
NOTICE IS HEREBY GIVEN that Savvy FL LLC First Horizon Collateral Assignee the holder of the following certificate(s) has filed said certificate(s) for a tax deed to be issued thereon.

FIRST INSERTION
NOTICE OF APPLICATION FOR TAX DEED
Section 197.512 F.S.
Tax Deed #:2024000912
NOTICE IS HEREBY GIVEN that Savvy FL LLC First Horizon Collateral Assignee the holder of the following certificate(s) has filed said certificate(s) for a tax deed to be issued thereon.

FIRST INSERTION
NOTICE OF APPLICATION FOR TAX DEED
Section 197.512 F.S.
Tax Deed #:2024000913
NOTICE IS HEREBY GIVEN that Savvy FL LLC First Horizon Collateral Assignee the holder of the following certificate(s) has filed said certificate(s) for a tax deed to be issued thereon.

FIRST INSERTION
NOTICE OF APPLICATION FOR TAX DEED
Section 197.512 F.S.
Tax Deed #:2024000818
NOTICE IS HEREBY GIVEN that Mikon Financial Services Inc and Ocean Bank the holder of the following certificate(s) has filed said certificate(s) for a tax deed to be issued thereon.

FIRST INSERTION
NOTICE OF APPLICATION FOR TAX DEED
Section 197.512 F.S.
Tax Deed #:2024000458
NOTICE IS HEREBY GIVEN that FIG 20, LLC FIG 20, LLC FBO SEC PTY the holder of the following certificate(s) has filed said certificate(s) for a tax deed to be issued thereon.

FIRST INSERTION
NOTICE OF APPLICATION FOR TAX DEED
Section 197.512 F.S.
Tax Deed #:2024000848
NOTICE IS HEREBY GIVEN that Savvy FL LLC First Horizon Collateral Assignee the holder of the following certificate(s) has filed said certificate(s) for a tax deed to be issued thereon.

FIRST INSERTION
NOTICE OF APPLICATION FOR TAX DEED
Section 197.512 F.S.
Tax Deed #:2024000795
NOTICE IS HEREBY GIVEN that Mikon Financial Services Inc and Ocean Bank the holder of the following certificate(s) has filed said certificate(s) for a tax deed to be issued thereon.

FIRST INSERTION
NOTICE OF APPLICATION FOR TAX DEED
Section 197.512 F.S.
Tax Deed #:2024000808
NOTICE IS HEREBY GIVEN that Mikon Financial Services Inc and Ocean Bank the holder of the following certificate(s) has filed said certificate(s) for a tax deed to be issued thereon.

FIRST INSERTION
NOTICE OF APPLICATION FOR TAX DEED
Section 197.512 F.S.
Tax Deed #:2024000800
NOTICE IS HEREBY GIVEN that Mikon Financial Services Inc and Ocean Bank the holder of the following certificate(s) has filed said certificate(s) for a tax deed to be issued thereon.

FIRST INSERTION
NOTICE OF APPLICATION FOR TAX DEED
Section 197.512 F.S.
Tax Deed #:2024000770
NOTICE IS HEREBY GIVEN that Mikon Financial Services Inc and Ocean Bank the holder of the following certificate(s) has filed said certificate(s) for a tax deed to be issued thereon.

FIRST INSERTION
NOTICE OF APPLICATION FOR TAX DEED
Section 197.512 F.S.
Tax Deed #:2024000806
NOTICE IS HEREBY GIVEN that Mikon Financial Services Inc and Ocean Bank the holder of the following certificate(s) has filed said certificate(s) for a tax deed to be issued thereon.

FIRST INSERTION
NOTICE OF APPLICATION FOR TAX DEED
Section 197.512 F.S.
Tax Deed #:2024000807
NOTICE IS HEREBY GIVEN that Mikon Financial Services Inc and Ocean Bank the holder of the following certificate(s) has filed said certificate(s) for a tax deed to be issued thereon.

FIRST INSERTION
NOTICE OF APPLICATION FOR TAX DEED
Section 197.512 F.S.
Tax Deed #:2024000887
NOTICE IS HEREBY GIVEN that Savvy FL LLC First Horizon Collateral Assignee the holder of the following certificate(s) has filed said certificate(s) for a tax deed to be issued thereon.

FIRST INSERTION
NOTICE OF APPLICATION FOR TAX DEED
Section 197.512 F.S.
Tax Deed #:2024000850
NOTICE IS HEREBY GIVEN that Savvy FL LLC First Horizon Collateral Assignee the holder of the following certificate(s) has filed said certificate(s) for a tax deed to be issued thereon.

FIRST INSERTION
NOTICE OF APPLICATION FOR TAX DEED
Section 197.512 F.S.
Tax Deed #:2024000931
NOTICE IS HEREBY GIVEN that Savvy FL LLC First Horizon Collateral Assignee the holder of the following certificate(s) has filed said certificate(s) for a tax deed to be issued thereon.

FIRST INSERTION
NOTICE OF APPLICATION FOR TAX DEED
Section 197.512 F.S.
Tax Deed #:2024000838
NOTICE IS HEREBY GIVEN that Savvy FL LLC First Horizon Collateral Assignee the holder of the following certificate(s) has filed said certificate(s) for a tax deed to be issued thereon.

FIRST INSERTION
NOTICE OF APPLICATION FOR TAX DEED
Section 197.512 F.S.
Tax Deed #:2024000869
NOTICE IS HEREBY GIVEN that Savvy FL LLC First Horizon Collateral Assignee the holder of the following certificate(s) has filed said certificate(s) for a tax deed to be issued thereon.

FIRST INSERTION
NOTICE OF APPLICATION FOR TAX DEED
Section 197.512 F.S.
Tax Deed #:2024000895
NOTICE IS HEREBY GIVEN that Savvy FL LLC First Horizon Collateral Assignee the holder of the following certificate(s) has filed said certificate(s) for a tax deed to be issued thereon.

--- PUBLIC SALES ---

FIRST INSERTION
Fictitious Name Notice
Notice Is Hereby Given that Lee Health System, Inc., 2776 Cleveland Ave, Fort Myers, FL 33901, desiring to engage in business under the fictitious name of LPG Orthopedics Cape Coral, with its principal place of business in the State of Florida in the County of Lee, intends to file an Application for Registration of Fictitious Name with the Florida Department of State.

FIRST INSERTION
Fictitious Name Notice
Notice Is Hereby Given that Lee Health System, Inc., 2776 Cleveland Ave, Fort Myers, FL 33901, desiring to engage in business under the fictitious name of LPG Primary Care at Page Field, with its principal place of business in the State of Florida in the County of Lee, intends to file an Application for Registration of Fictitious Name with the Florida Department of State.

FIRST INSERTION
Fictitious Name Notice
Notice Is Hereby Given that Lee Health System, Inc., 2776 Cleveland Ave, Fort Myers, FL 33901, desiring to engage in business under the fictitious name of LPG Pulmonary Associates, with its principal place of business in the State of Florida in the County of Lee, intends to file an Application for Registration of Fictitious Name with the Florida Department of State.

FIRST INSERTION
Fictitious Name Notice
Notice Is Hereby Given that Lee Health System, Inc., 2776 Cleveland Ave, Fort Myers, FL 33901, desiring to engage in business under the fictitious name of LPG Pulmonary at Metro, with its principal place of business in the State of Florida in the County of Lee, intends to file an Application for Registration of Fictitious Name with the Florida Department of State.

FIRST INSERTION
Fictitious Name Notice
Notice Is Hereby Given that Lee Health System, Inc., 2776 Cleveland Ave, Fort Myers, FL 33901, desiring to engage in business under the fictitious name of LPG Pulmonology-Coconut Point, with its principal place of business in the State of Florida in the County of Lee, intends to file an Application for Registration of Fictitious Name with the Florida Department of State.

FIRST INSERTION
Fictitious Name Notice
Notice Is Hereby Given that Lee Health System, Inc., 2776 Cleveland Ave, Fort Myers, FL 33901, desiring to engage in business under the fictitious name of LPG Pulmonology-HP, with its principal place of business in the State of Florida in the County of Lee, intends to file an Application for Registration of Fictitious Name with the Florida Department of State.

Q&A What is a public notice? A public notice is information intended to inform citizens of government activities. The notice should be published in a forum independent of the government, readily available to the public, capable of being securely archived and verified by authenticity. The West Orange Times carries public notices in Orange County, Florida.

--- TAX DEEDS ---

FIRST INSERTION
NOTICE OF APPLICATION FOR TAX DEED
Section 197.512 F.S.
Tax Deed #:2024000937
NOTICE IS HEREBY GIVEN that Savvy FL LLC First Horizon Collateral Assignee the holder of the following certificate(s) has filed said certificate(s) for a tax deed to be issued thereon.

FIRST INSERTION
NOTICE OF APPLICATION FOR TAX DEED
Section 197.512 F.S.
Tax Deed #:2024000860
NOTICE IS HEREBY GIVEN that Savvy FL LLC First Horizon Collateral Assignee the holder of the following certificate(s) has filed said certificate(s) for a tax deed to be issued thereon.

FIRST INSERTION
NOTICE OF APPLICATION FOR TAX DEED
Section 197.512 F.S.
Tax Deed #:2024000812
NOTICE IS HEREBY GIVEN that Mikon Financial Services Inc and Ocean Bank the holder of the following certificate(s) has filed said certificate(s) for a tax deed to be issued thereon.

FIRST INSERTION
NOTICE OF APPLICATION FOR TAX DEED
Section 197.512 F.S.
Tax Deed #:2024000938
NOTICE IS HEREBY GIVEN that Savvy FL LLC First Horizon Collateral Assignee the holder of the following certificate(s) has filed said certificate(s) for a tax deed to be issued thereon.

FIRST INSERTION
NOTICE OF APPLICATION FOR TAX DEED
Section 197.512 F.S.
Tax Deed #:2024000878
NOTICE IS HEREBY GIVEN that Savvy FL LLC First Horizon Collateral Assignee the holder of the following certificate(s) has filed said certificate(s) for a tax deed to be issued thereon.

FIRST INSERTION
NOTICE OF APPLICATION FOR TAX DEED
Section 197.512 F.S.
Tax Deed #:2024000939
NOTICE IS HEREBY GIVEN that Savvy FL LLC First Horizon Collateral Assignee the holder of the following certificate(s) has filed said certificate(s) for a tax deed to be issued thereon.

FIRST INSERTION
NOTICE OF APPLICATION FOR TAX DEED
Section 197.512 F.S.
Tax Deed #:2024000829
NOTICE IS HEREBY GIVEN that Savvy FL LLC First Horizon Collateral Assignee the holder of the following certificate(s) has filed said certificate(s) for a tax deed to be issued thereon.

FIRST INSERTION
NOTICE OF APPLICATION FOR TAX DEED
Section 197.512 F.S.
Tax Deed #:2024000810
NOTICE IS HEREBY GIVEN that Mikon Financial Services Inc and Ocean Bank the holder of the following certificate(s) has filed said certificate(s) for a tax deed to be issued thereon.

FIRST INSERTION
NOTICE OF APPLICATION FOR TAX DEED
Section 197.512 F.S.
Tax Deed #:2024000863
NOTICE IS HEREBY GIVEN that Savvy FL LLC First Horizon Collateral Assignee the holder of the following certificate(s) has filed said certificate(s) for a tax deed to be issued thereon.

FIRST INSERTION
NOTICE OF APPLICATION FOR TAX DEED
Section 197.512 F.S.
Tax Deed #:2024000785
NOTICE IS HEREBY GIVEN that Mikon Financial Services Inc and Ocean Bank the holder of the following certificate(s) has filed said certificate(s) for a tax deed to be issued thereon.

FIRST INSERTION
NOTICE OF APPLICATION FOR TAX DEED
Section 197.512 F.S.
Tax Deed #:2024000819
NOTICE IS HEREBY GIVEN that Mikon Financial Services Inc and Ocean Bank the holder of the following certificate(s) has filed said certificate(s) for a tax deed to be issued thereon.

FIRST INSERTION
NOTICE OF APPLICATION FOR TAX DEED
Section 197.512 F.S.
Tax Deed #:2023002140
NOTICE IS HEREBY GIVEN that MELINDA CHRISTENSEN CHRISTENSEN CAPITAL LLC the holder of the following certificate(s) has filed said certificate(s) for a tax deed to be issued thereon.

FIRST INSERTION
NOTICE OF APPLICATION FOR TAX DEED
Section 197.512 F.S.
Tax Deed #:2024000899
NOTICE IS HEREBY GIVEN that Savvy FL LLC First Horizon Collateral Assignee the holder of the following certificate(s) has filed said certificate(s) for a tax deed to be issued thereon.

FIRST INSERTION
NOTICE OF APPLICATION FOR TAX DEED
Section 197.512 F.S.
Tax Deed #:2024000900
NOTICE IS HEREBY GIVEN that Savvy FL LLC First Horizon Collateral Assignee the holder of the following certificate(s) has filed said certificate(s) for a tax deed to be issued thereon.

FIRST INSERTION
NOTICE OF APPLICATION FOR TAX DEED
Section 197.512 F.S.
Tax Deed #:2024000916
NOTICE IS HEREBY GIVEN that Savvy FL LLC First Horizon Collateral Assignee the holder of the following certificate(s) has filed said certificate(s) for a tax deed to be issued thereon.

FIRST INSERTION
NOTICE OF APPLICATION FOR TAX DEED
Section 197.512 F.S.
Tax Deed #:2024000821
NOTICE IS HEREBY GIVEN that Mikon Financial Services Inc and Ocean Bank the holder of the following certificate(s) has filed said certificate(s) for a tax deed to be issued thereon.

FIRST INSERTION
NOTICE OF APPLICATION FOR TAX DEED
Section 197.512 F.S.
Tax Deed #:2024000941
NOTICE IS HEREBY GIVEN that Savvy FL LLC First Horizon Collateral Assignee the holder of the following certificate(s) has filed said certificate(s) for a tax deed to be issued thereon.

FIRST INSERTION
NOTICE OF APPLICATION FOR TAX DEED
Section 197.512 F.S.
Tax Deed #:2024000892
NOTICE IS HEREBY GIVEN that Savvy FL LLC First Horizon Collateral Assignee the holder of the following certificate(s) has filed said certificate(s) for a tax deed to be issued thereon.

--- PUBLIC SALES ---

FIRST INSERTION
Fictitious Name Notice
Notice Is Hereby Given that Lee Health System, Inc., 2776 Cleveland Ave, Fort Myers, FL 33901, desiring to engage in business under the fictitious name of LPG OB/GYN Palm Beach, with its principal place of business in the State of Florida in the County of Lee, intends to file an Application for Registration of Fictitious Name with the Florida Department of State.

FIRST INSERTION
Fictitious Name Notice
Notice Is Hereby Given that Lee Health System, Inc., 2776 Cleveland Ave, Fort Myers, FL 33901, desiring to engage in business under the fictitious name of LPG Pain Management Coconut Point, with its principal place of business in the State of Florida in the County of Lee, intends to file an Application for Registration of Fictitious Name with the Florida Department of State.

FIRST INSERTION
Fictitious Name Notice
Notice Is Hereby Given that Lee Health System, Inc., 2776 Cleveland Ave, Fort Myers, FL 33901, desiring to engage in business under the fictitious name of LPG Pediatric Surgical Specialties, with its principal place of business in the State of Florida in the County of Lee, intends to file an Application for Registration of Fictitious Name with the Florida Department of State.

FIRST INSERTION
Fictitious Name Notice
Notice Is Hereby Given that Lee Health System, Inc., 2776 Cleveland Ave, Fort Myers, FL 33901, desiring to engage in business under the fictitious name of LPG Pediatrics Cape Coral, with its principal place of business in the State of Florida in the County of Lee, intends to file an Application for Registration of Fictitious Name with the Florida Department of State.

FIRST INSERTION
Fictitious Name Notice
Notice Is Hereby Given that Lee Health System, Inc., 2776 Cleveland Ave, Fort Myers, FL 33901, desiring to engage in business under the fictitious name of LPG Pediatrics Lehigh Acres, with its principal place of business in the State of Florida in the County of Lee, intends to file an Application for Registration of Fictitious Name with the Florida Department of State.

FIRST INSERTION
Fictitious Name Notice
Notice Is Hereby Given that Lee Health System, Inc., 2776 Cleveland Ave, Fort Myers, FL 33901, desiring to engage in business under the fictitious name of LPG Pediatrics Surgical Specialties, with its principal place of business in the State of Florida in the County of Lee, intends to file an Application for Registration of Fictitious Name with the Florida Department of State.

PUBLISH YOUR LEGAL NOTICE

Call 941-906-9386

and select the appropriate County name from the menu option

or email legal@businessobserverfl.com

FLORIDA'S NEWSPAPER FOR THE C-SUITE



10/2023 12.8

--- TAX DEEDS ---

FIRST INSERTION
NOTICE OF APPLICATION FOR TAX DEED
Section 197.512 F.S.
Tax Deed #:2024000910
NOTICE IS HEREBY GIVEN that Savvy FL LLC First Horizon Collateral Assignee the holder of the following certificate(s) has filed said certificate(s) for a tax deed to be issued thereon.

FIRST INSERTION
NOTICE OF APPLICATION FOR TAX DEED
Section 197.512 F.S.
Tax Deed #:2024000651
NOTICE IS HEREBY GIVEN that TLOA OF FLORIDA LLC FOR SECURED PARTY the holder of the following certificate(s) has filed said certificate(s) for a tax deed to be issued thereon.

FIRST INSERTION
NOTICE OF APPLICATION FOR TAX DEED
Section 197.512 F.S.
Tax Deed #:2024000926
NOTICE IS HEREBY GIVEN that Savvy FL LLC First Horizon Collateral Assignee the holder of the following certificate(s) has filed said certificate(s) for a tax deed to be issued thereon.

FIRST INSERTION
NOTICE OF APPLICATION FOR TAX DEED
Section 197.512 F.S.
Tax Deed #:2024000928
NOTICE IS HEREBY GIVEN that Savvy FL LLC First Horizon Collateral Assignee the holder of the following certificate(s) has filed said certificate(s) for a tax deed to be issued thereon.

FIRST INSERTION
NOTICE OF APPLICATION FOR TAX DEED
Section 197.512 F.S.
Tax Deed #:2024000870
NOTICE IS HEREBY GIVEN that Savvy FL LLC First Horizon Collateral Assignee the holder of the following certificate(s) has filed said certificate(s) for a tax deed to be issued thereon.

FIRST INSERTION
NOTICE OF APPLICATION FOR TAX DEED
Section 197.512 F.S.
Tax Deed #:2024000883
NOTICE IS HEREBY GIVEN that Savvy FL LLC First Horizon Collateral Assignee the holder of the following certificate(s) has filed said certificate(s) for a tax deed to be issued thereon.

FIRST INSERTION
NOTICE OF APPLICATION FOR TAX DEED
Section 197.512 F.S.
Tax Deed #:2024000840
NOTICE IS HEREBY GIVEN that Savvy FL LLC First Horizon Collateral Assignee the holder of the following certificate(s) has filed said certificate(s) for a tax deed to be issued thereon.

FIRST INSERTION
NOTICE OF APPLICATION FOR TAX DEED
Section 197.512 F.S.
Tax Deed #:2024000843
NOTICE IS HEREBY GIVEN that Savvy FL LLC First Horizon Collateral Assignee the holder of the following certificate(s) has filed said certificate(s) for a tax deed to be issued thereon.

FIRST INSERTION
NOTICE OF APPLICATION FOR TAX DEED
Section 197.512 F.S.
Tax Deed #:2024000852
NOTICE IS HEREBY GIVEN that Savvy FL LLC First Horizon Collateral Assignee the holder of the following certificate(s) has filed said certificate(s) for a tax deed to be issued thereon.

FIRST INSERTION
NOTICE OF APPLICATION FOR TAX DEED
Section 197.512 F.S.
Tax Deed #:2024000853
NOTICE IS HEREBY GIVEN that Savvy FL LLC First Horizon Collateral Assignee the holder of the following certificate(s) has filed said certificate(s) for a tax deed to be issued thereon.

FIRST INSERTION
NOTICE OF APPLICATION FOR TAX DEED
Section 197.512 F.S.
Tax Deed #:2024000935
NOTICE IS HEREBY GIVEN that Savvy FL LLC First Horizon Collateral Assignee the holder of the following certificate(s) has filed said certificate(s) for a tax deed to be issued thereon.

FIRST INSERTION
NOTICE OF APPLICATION FOR TAX DEED
Section 197.512 F.S.
Tax Deed #:2024000897
NOTICE IS HEREBY GIVEN that Savvy FL LLC First Horizon Collateral Assignee the holder of the following certificate(s) has filed said certificate(s) for a tax deed to be issued thereon.

FIRST INSERTION
NOTICE OF APPLICATION FOR TAX DEED
Section 197.512 F.S.
Tax Deed #:2024000886
NOTICE IS HEREBY GIVEN that Savvy FL LLC First Horizon Collateral Assignee the holder of the following certificate(s) has filed said certificate(s) for a tax deed to be issued thereon.

FIRST INSERTION
NOTICE OF APPLICATION FOR TAX DEED
Section 197.512 F.S.
Tax Deed #:2024000896
NOTICE IS HEREBY GIVEN that Savvy FL LLC First Horizon Collateral Assignee the holder of the following certificate(s) has filed said certificate(s) for a tax deed to be issued thereon.

FIRST INSERTION
NOTICE OF APPLICATION FOR TAX DEED
Section 197.512 F.S.
Tax Deed #:2024000915
NOTICE IS HEREBY GIVEN that Savvy FL LLC First Horizon Collateral Assignee the holder of the following certificate(s) has filed said certificate(s) for a tax deed to be issued thereon.

FIRST INSERTION
NOTICE OF APPLICATION FOR TAX DEED
Section 197.512 F.S.
Tax Deed #:2024000822
NOTICE IS HEREBY GIVEN that Mikon Financial Services Inc and Ocean Bank the holder of the following certificate(s) has filed said certificate(s) for a tax deed to be issued thereon.

FIRST INSERTION
NOTICE OF APPLICATION FOR TAX DEED
Section 197.512 F.S.
Tax Deed #:2024000779
NOTICE IS HEREBY GIVEN that Mikon Financial Services Inc and Ocean Bank the holder of the following certificate(s) has filed said certificate(s) for a tax deed to be issued thereon.

FIRST INSERTION
NOTICE OF APPLICATION FOR TAX DEED
Section 197.512 F.S.
Tax Deed #:2024000859
NOTICE IS HEREBY GIVEN that Savvy FL LLC First Horizon Collateral Assignee the holder of the following certificate(s) has filed said certificate(s) for a tax deed to be issued thereon.

--- PUBLIC SALES ---

FIRST INSERTION
Fictitious Name Notice
Notice Is Hereby Given that Lee Health System, Inc., 2776 Cleveland Ave, Fort Myers, FL 33901, desiring to engage in business under the fictitious name of LPG Neurosurgery Cape Coral, with its principal place of business in the State of Florida in the County of Lee, intends to file an Application for Registration of Fictitious Name with the Florida Department of State.

FIRST INSERTION
Fictitious Name Notice
Notice Is Hereby Given that Lee Health System, Inc., 2776 Cleveland Ave, Fort Myers, FL 33901, desiring to engage in business under the fictitious name of LPG Neurosurgery Gulf Coast, with its principal place of business in the State of Florida in the County of Lee, intends to file an Application for Registration of Fictitious Name with the Florida Department of State.

FIRST INSERTION
Fictitious Name Notice
Notice Is Hereby Given that Lee Health System, Inc., 2776 Cleveland Ave, Fort Myers, FL 33901, desiring to engage in business under the fictitious name of LPG OB GYN at Bass Road, with its principal place of business in the State of Florida in the County of Lee, intends to file an Application for Registration of Fictitious Name with the Florida Department of State.

FIRST INSERTION
Fictitious Name Notice
Notice Is Hereby Given that Lee Health System, Inc., 2776 Cleveland Ave, Fort Myers, FL 33901, desiring to engage in business under the fictitious name of LPG OB GYN at Labelle, with its principal place of business in the State of Florida in the County of Lee, intends to file an Application for Registration of Fictitious Name with the Florida Department of State.

FIRST INSERTION
Fictitious Name Notice
Notice Is Hereby Given that Lee Health System, Inc., 2776 Cleveland Ave, Fort Myers, FL 33901, desiring to engage in business under the fictitious name of LPG OB GYN at Page Field, with its principal place of business in the State of Florida in the County of Lee, intends to file an Application for Registration of Fictitious Name with the Florida Department of State.

FIRST INSERTION
Fictitious Name Notice
Notice Is Hereby Given that Lee Health System, Inc., 2776 Cleveland Ave, Fort Myers, FL 33901, desiring to engage in business under the fictitious name of LPG OB GYN at Pine Island Road, with its principal place of business in the State of Florida in the County of Lee, intends to file an Application for Registration of Fictitious Name with the Florida Department of State.

SAVE TIME
Image of a clock and text: SAVE TIME

Email your Legal Notice
legal@businessobserverfl.com
Deadline Wednesday at noon
Friday Publication

SARASOTA • MANATEE • HILLSBOROUGH • PASCO
PINELLAS • POLK • LEE • COLLIER • CHARLOTTE
Business Observer
FLORIDA'S NEWSPAPER FOR THE C-SUITE

--- TAX DEEDS ---

FIRST INSERTION
NOTICE OF APPLICATION FOR TAX DEED
Section 197.512 F.S.
 Tax Deed #:2024000867
 NOTICE IS HEREBY GIVEN that Savvy FL LLC First Horizon Collateral Assignee the holder of the following certificate(s) has filed said certificate(s) for a tax deed to be issued thereon. The certificate number(s), year(s) of issuance, the description of the property and the name(s) in which it was assessed are as follows:
 Certificate Number: 90-11 Year of Issuance 2022 Description of Property FT MYERS ESTATES BLK 17 PB 6 PG 44 LOT 5 LESS ROAD Strap Number 20-44-25-P2-00117.0050
 Names in which assessed: ALEXIS FLETCHER
 All of said property being in the County of Lee, State of Florida. Unless such certificate(s) shall be redeemed according to the law the property described in such certificate(s) will be sold to the highest bidder online at www.lee.realtaxdeed.com on 11/19/2024 at 10:00 am, by Kevin C. Karnes, Lee County Clerk of the Circuit Court & Comptroller.
 Sept. 27; Oct. 4, 11, 18, 2024
 24-03989L

FIRST INSERTION
NOTICE OF APPLICATION FOR TAX DEED
Section 197.512 F.S.
 Tax Deed #:2024000864
 NOTICE IS HEREBY GIVEN that Savvy FL LLC First Horizon Collateral Assignee the holder of the following certificate(s) has filed said certificate(s) for a tax deed to be issued thereon. The certificate number(s), year(s) of issuance, the description of the property and the name(s) in which it was assessed are as follows:
 Certificate Number: 87-27 Year of Issuance 2022 Description of Property CORRIGANS ALLEN ST RESUB PB 5 PG 18 LOT 17 Strap Number 18-44-25-P1-02700.0170
 Names in which assessed: DOUGLAS CARRINGTON
 All of said property being in the County of Lee, State of Florida. Unless such certificate(s) shall be redeemed according to the law the property described in such certificate(s) will be sold to the highest bidder online at www.lee.realtaxdeed.com on 11/19/2024 at 10:00 am, by Kevin C. Karnes, Lee County Clerk of the Circuit Court & Comptroller.
 Sept. 27; Oct. 4, 11, 18, 2024
 24-03988L

FIRST INSERTION
NOTICE OF APPLICATION FOR TAX DEED
Section 197.512 F.S.
 Tax Deed #:2024000925
 NOTICE IS HEREBY GIVEN that Savvy FL LLC First Horizon Collateral Assignee the holder of the following certificate(s) has filed said certificate(s) for a tax deed to be issued thereon. The certificate number(s), year(s) of issuance, the description of the property and the name(s) in which it was assessed are as follows:
 Certificate Number: 19-663 Year of Issuance 2022 Description of Property LEHIGH ACRES UNIT 10 BLK 37 PB 15 PG 160 LOT 13 Strap Number 11-45-27-10-00037.0130
 Names in which assessed: ELEANOR FRANCES GIANNINI, LEO MICHAEL GIANNINI, UNKNOWN HEIRS OF LEO M GIANNINI
 All of said property being in the County of Lee, State of Florida. Unless such certificate(s) shall be redeemed according to the law the property described in such certificate(s) will be sold to the highest bidder online at www.lee.realtaxdeed.com on 11/19/2024 at 10:00 am, by Kevin C. Karnes, Lee County Clerk of the Circuit Court & Comptroller.
 Sept. 27; Oct. 4, 11, 18, 2024
 24-03961L

FIRST INSERTION
NOTICE OF APPLICATION FOR TAX DEED
Section 197.512 F.S.
 Tax Deed #:2024000866
 NOTICE IS HEREBY GIVEN that Savvy FL LLC First Horizon Collateral Assignee the holder of the following certificate(s) has filed said certificate(s) for a tax deed to be issued thereon. The certificate number(s), year(s) of issuance, the description of the property and the name(s) in which it was assessed are as follows:
 Certificate Number: 17-053 Year of Issuance 2022 Description of Property LEHIGH ACRES UNIT 4 BLK 22 DB 252 PG 234 LOT 9 Strap Number 19-44-27-04-00022.0090
 Names in which assessed: ESTATE OF JAMES E BRANSON, GENEVIEVE BRANSON, UNKNOWN HEIRS OF JAMES EARL BRANSON
 All of said property being in the County of Lee, State of Florida. Unless such certificate(s) shall be redeemed according to the law the property described in such certificate(s) will be sold to the highest bidder online at www.lee.realtaxdeed.com on 11/19/2024 at 10:00 am, by Kevin C. Karnes, Lee County Clerk of the Circuit Court & Comptroller.
 Sept. 27; Oct. 4, 11, 18, 2024
 24-03948L

FIRST INSERTION
NOTICE OF APPLICATION FOR TAX DEED
Section 197.512 F.S.
 Tax Deed #:2024000799
 NOTICE IS HEREBY GIVEN that Mikon Financial Services Inc and Ocean Bank the holder of the following certificate(s) has filed said certificate(s) for a tax deed to be issued thereon. The certificate number(s), year(s) of issuance, the description of the property and the name(s) in which it was assessed are as follows:
 Certificate Number: 77-54 Year of Issuance 2022 Description of Property SMUGGLERS COVE CONDO BLDG B OR 1225 PG 555 APT 6B4 Strap Number 28-46-24-W4-02106.0B40
 Names in which assessed: JOSEPH COAN TR, MARINA J SWEET TR, UNIFIED CREDIT TRUST UNDER THE LAST WILL AND TESTAMENT OF BARBARA COAN
 All of said property being in the County of Lee, State of Florida. Unless such certificate(s) shall be redeemed according to the law the property described in such certificate(s) will be sold to the highest bidder online at www.lee.realtaxdeed.com on 11/19/2024 at 10:00 am, by Kevin C. Karnes, Lee County Clerk of the Circuit Court & Comptroller.
 Sept. 27; Oct. 4, 11, 18, 2024
 24-03986L

FIRST INSERTION
NOTICE OF APPLICATION FOR TAX DEED
Section 197.512 F.S.
 Tax Deed #:2024000849
 NOTICE IS HEREBY GIVEN that Savvy FL LLC First Horizon Collateral Assignee the holder of the following certificate(s) has filed said certificate(s) for a tax deed to be issued thereon. The certificate number(s), year(s) of issuance, the description of the property and the name(s) in which it was assessed are as follows:
 Certificate Number: 62-02 Year of Issuance 2022 Description of Property EVANS ADD BLK 14 PB 1 P 29 LOTS PT 20 + 22 DESC IN OR 159 P 598 LES R/W OR 2960 PG 3083 Strap Number 13-44-24-P3-00614.0220
 Names in which assessed: SWFL ASSET HOLDINGS, LLC
 All of said property being in the County of Lee, State of Florida. Unless such certificate(s) shall be redeemed according to the law the property described in such certificate(s) will be sold to the highest bidder online at www.lee.realtaxdeed.com on 11/19/2024 at 10:00 am, by Kevin C. Karnes, Lee County Clerk of the Circuit Court & Comptroller.
 Sept. 27; Oct. 4, 11, 18, 2024
 24-03985L

FIRST INSERTION
NOTICE OF APPLICATION FOR TAX DEED
Section 197.512 F.S.
 Tax Deed #:2024001163
 NOTICE IS HEREBY GIVEN that Mikon Financial Services Inc and Ocean Bank the holder of the following certificate(s) has filed said certificate(s) for a tax deed to be issued thereon. The certificate number(s), year(s) of issuance, the description of the property and the name(s) in which it was assessed are as follows:
 Certificate Number: 38-03 Year of Issuance 2022 Description of Property CAPE CORAL UNIT 26 BLK 836 PB 14 PG 119 LOTS 53 + 54 Strap Number 01-45-23-C4-00836.0530
 Names in which assessed: JAMES P FOX II, JAMES P FOX III, JAMES PAUL FOX III, MICHAEL R FOX III, MICHELLE RENEE FOX BENNETT, MICHELLE RENEE FOX BENNETT, UNKNOWN HEIRS JAMES PAUL FOX II, UNKNOWN HEIRS OF HELEN M FOX
 All of said property being in the County of Lee, State of Florida. Unless such certificate(s) shall be redeemed according to the law the property described in such certificate(s) will be sold to the highest bidder online at www.lee.realtaxdeed.com on 11/19/2024 at 10:00 am, by Kevin C. Karnes, Lee County Clerk of the Circuit Court & Comptroller.
 Sept. 27; Oct. 4, 11, 18, 2024
 24-03980L

FIRST INSERTION
NOTICE OF APPLICATION FOR TAX DEED
Section 197.512 F.S.
 Tax Deed #:2024000811
 NOTICE IS HEREBY GIVEN that Mikon Financial Services Inc and Ocean Bank the holder of the following certificate(s) has filed said certificate(s) for a tax deed to be issued thereon. The certificate number(s), year(s) of issuance, the description of the property and the name(s) in which it was assessed are as follows:
 Certificate Number: 54-92 Year of Issuance 2022 Description of Property PALMONA PARK UNIT 1 BLK 19 PB 7 PG 54 LOTS 13 THRU 16 INCL Strap Number 34-43-24-01-00019.0130
 Names in which assessed: ABUL KHAIR HAQUE, DILIP CHANDRA DAS, MD HASANUZZAMAN CHOWDHURY, MD SHAHIDUL ISLAM, MOHAMMAD ASHIQUR RAHMAN, NAZMUN AKHTER
 All of said property being in the County of Lee, State of Florida. Unless such certificate(s) shall be redeemed according to the law the property described in such certificate(s) will be sold to the highest bidder online at www.lee.realtaxdeed.com on 11/19/2024 at 10:00 am, by Kevin C. Karnes, Lee County Clerk of the Circuit Court & Comptroller.
 Sept. 27; Oct. 4, 11, 18, 2024
 24-03984L

FIRST INSERTION
CITATION BY PUBLICATION
Cause No. 2024-PRO1826-2
 THE STATE OF TEXAS
 COUNTY OF TARRANT
 TO: SHANNON SOFFIAN, 1630 NW 11TH TERRACE, CAPE CORAL, FLORIDA 33993 AND THE KNOWN AND UNKNOWN HEIRS AT LAW AND ANY PERSONS INTERESTED IN THE ESTATE OF CARROLL BENJAMIN MORRIS, III, DECEASED
 All persons interested in this case are cited to appear before this Honorable Court by filing a written answer or contest with the Clerk of the Court for Probate Court No. 2 of Tarrant County, Texas at Courthouse located at 100 W. Weatherford, 2nd floor, Fort Worth, Tarrant County, Texas, on October 07, 2024, which is the first Monday after the expiration of Ten (10) days from the date of publication, then and there to answer said Application for Probate of Will Not Produced in Court and Issuance of Letters Testamentary of LINDA CAVANAUGH filed on June 14, 2024 and show cause why this Court should not render in the estate of CARROLL BENJAMIN MORRIS, III, DECEASED.
 Petitioner alleges that the decedent died in Fort Worth, Texas on July 17, 2020 and prays the Court hear evidence sufficient to determine who are the heirs and only heirs of CARROLL BENJAMIN MORRIS, III, DECEASED.
 GIVEN UNDER MY HAND AND SEAL of said Court at the office in the City of Fort Worth, Texas, Tarrant County, Texas 20th day of September 2024 A.D.
 (SEAL) Lai Sun Dinrock, Deputy Clerk
 Mary Louise Nicholson, County Clerk
 Tarrant County, Texas
 100 W. Weatherford Street
 Fort Worth, Texas 76196-0401
 Corey D. Williams
 Law Office of Corey D Williams PLLC
 3301 West Freeway Ste 103
 Fort Worth TX 76107
 817-224-2954
 Sept. 27; Oct. 4, 2024 24-04249L

FIRST INSERTION
NOTICE TO CREDITORS
 IN THE CIRCUIT COURT FOR LEE COUNTY, FLORIDA
 Probate Division
CASE NO.: 24-CP-002108 P(3)
IN RE: ESTATE OF MARGARET L. MOORE, Deceased.
 The administration of the estate of Margaret L. Moore, deceased, whose date of death was July 12, 2023, is pending in the Circuit Court for Lee County, Florida, Probate Division, the address of which is 1700 Monroe Street, Fort Myers, FL 33901. The names and addresses of the Personal Representative and the Personal Representative's attorney are set forth below.
 All creditors of the decedent and other persons who have claims or demands against decedent's estate, on whom a copy of this notice is required to be served, must file their claims with this court WITHIN THE LATER OF THREE (3) MONTHS AFTER THE DATE OF THE FIRST PUBLICATION OF THIS NOTICE OR THIRTY (30) DAYS AFTER THE DATE OF SERVICE OF A COPY OF THIS NOTICE ON THEM.
 All other creditors of the Decedent and other persons having claims or demands against decedent's estate, must file their claims with this court WITHIN THREE (3) MONTHS AFTER THE DATE OF THE FIRST PUBLICATION OF THIS NOTICE.
 ALL CLAIMS NOT SO FILED WILL BE FOREVER BARRED.
 The date of first publication of this notice is September 27, 2024.
Personal Representative:
Carolyn M. Ange,
 3846 Anderson Chapel Road, Macclesfield, North Carolina 27852
 Attorney for Personal Representative: P. Scott Miller, Florida Bar No. 0093792, 1843 Foreman Drive, Suite 210, Cookeville, Tennessee 38501
 Tele: 727-362-3700
 Fax: 727-398-3907
 E-Mail: smiller@gibbsfirm.com
 Secondary E-Mail: dmiller@gibbsfirm.com
 Sept. 27; Oct. 4, 2024 24-04227L

FIRST INSERTION
NOTICE TO CREDITORS
 IN THE CIRCUIT COURT FOR LEE COUNTY, FLORIDA
 PROBATE DIVISION
File No. 24-CP-002612
IN RE: ESTATE OF LE ROY MOULTRIE a/k/a Leroy Moultrie Deceased.
 The administration of the Estate of Le Roy Moultrie, deceased, whose date of death was May 18, 2024, is pending in the Circuit Court for Lee County, Florida, Probate Division, the address of which is Justice Center, 1st Floor, 1700 Monroe St., Ft. Myers, FL 33901. The names and addresses of the Personal Representative and the Personal Representative's attorney are set forth below.
 All creditors of the decedent and other persons having claims or demands against decedent's Estate on whom a copy of this notice is required to be served must file their claims with this court ON OR BEFORE THE LATER OF 3 MONTHS AFTER THE TIME OF THE FIRST PUBLICATION OF THIS NOTICE OR 30 DAYS AFTER THE DATE OF SERVICE OF A COPY OF THIS NOTICE ON THEM.
 All other creditors of the decedent and other persons having claims or demands against decedent's Estate must file their claims with this court WITHIN 3 MONTHS AFTER THE DATE OF THE FIRST PUBLICATION OF THIS NOTICE.
 ALL CLAIMS NOT FILED WITHIN THE TIME PERIODS SET FORTH IN FLORIDA STATUTES SECTION 733.702 WILL BE FOREVER BARRED.
 NOTWITHSTANDING THE TIME PERIODS SET FORTH ABOVE, ANY CLAIM FILED TWO (2) YEARS OR MORE AFTER THE DECEDENT'S DATE OF DEATH IS BARRED.
 A Personal Representative or curator has no duty to discover whether any property held at the time of the decedent's death by the decedent or the decedent's surviving spouse is property to which the Florida Uniform Disposition of Community Property Rights at Death Act as described in sections 732.216-732.228, applies, or may apply, unless a written demand is made by a creditor as specified under section 732.2211.
 The date of first publication of this notice is September 27, 2024.
Personal Representative:
Marc Antonius Moultrie
 15413 East 18th Ave.
 Aurora, Colorado 80011
 Attorney for Personal Representative: Cyrus Malhotra, Esq.
 Florida Bar Number: 0022751
 THE MALHOTRA LAW FIRM P.A.
 3903 Northdale Blvd., Suite 100E
 Tampa, FL 33624
 Telephone: (813) 902-2119
 Fax: (727) 290-4044
 E-Mail: filings@FLprobatesolutions.com
 Secondary E-Mail: cortney@FLprobatesolutions.com
 Sept. 27; Oct. 4, 2024 24-04247L

FIRST INSERTION
NOTICE TO CREDITORS
 IN THE CIRCUIT COURT OF THE TWENTIETH JUDICIAL CIRCUIT IN AND FOR LEE COUNTY, FLORIDA
 PROBATE DIVISION
File No. 24-CP-002844
IN RE: ESTATE OF JANICE MARIE KOSTER, aka JANICE M. KOSTER Deceased.
 The administration of the estate of JANICE MARIE KOSTER, also known as JANICE M. KOSTER, deceased, whose date of death was April 17, 2024, is pending in the Circuit Court for Lee County, Florida, Probate Division, the address of which is 2075 Dr. Martin Luther King Jr. Blvd., Fort Myers, FL 33901. The names and addresses of the personal representative and the personal representative's attorney are set forth below.
 All creditors of the decedent and other persons having claims or demands against decedent's estate, on whom a copy of this notice is required to be served, must file their claims with this court ON OR BEFORE THE LATER OF 3 MONTHS AFTER THE TIME OF THE FIRST PUBLICATION OF THIS NOTICE OR 30 DAYS AFTER THE DATE OF SERVICE OF A COPY OF THIS NOTICE ON THEM.
 All other creditors of the decedent and other persons having claims or demands against decedent's estate must file their claims with this court WITHIN 3 MONTHS AFTER THE DATE OF THE FIRST PUBLICATION OF THIS NOTICE.
 ALL CLAIMS NOT FILED WITHIN THE TIME PERIODS SET FORTH IN FLORIDA STATUTES SECTION 733.702 WILL BE FOREVER BARRED.
 NOTWITHSTANDING THE TIME PERIOD SET FORTH ABOVE, ANY CLAIM FILED TWO (2) YEARS OR MORE AFTER THE DECEDENT'S DATE OF DEATH IS BARRED.
 The date of first publication of this notice is: September 27, 2024.
Personal Representative:
CARI LEIGH PAYNE
 Personal Representative
 7654 Kittery Lane
 Mentor, Ohio 44060
 GEENA G. KANDEL, ESQ.
 Attorney for Personal Representative
 Florida Bar No. 1019226
 Roetzal & Address LPA
 999 Vanderbilt Beach Road, Suite 401
 Naples, Florida 34108
 Telephone: (239) 649-6200
 Email: gkandel@ralaw.com
 Secondary Email: serve.gkandel@ralaw.com
 Sept. 27; Oct. 4, 2024 24-04229L

--- ESTATE ---

FIRST INSERTION
NOTICE TO CREDITORS
 IN THE CIRCUIT COURT FOR LEE COUNTY, FLORIDA
 PROBATE DIVISION
File Number: 24-CP-001396
IN RE: ESTATE OF HARRY GEORGE HALL Deceased.
 The administration of the estate of HARRY GEORGE HALL, deceased, whose date of death was September 9, 2023 and whose social security number is XXX-XX-6257, is pending in the Circuit Court for Lee County, Florida, Probate Division, the address of which is 2075 Dr. Martin Luther King Jr., Blvd., Ft. Myers, Florida 33901. The names and addresses of the personal representative and the personal representative's attorney are set forth below.
 All creditors of the decedent and other persons having claims or demands against decedent's estate on whom a copy of this notice is required to be served must file their claims with this court WITHIN THE LATER OF 3 MONTHS AFTER THE TIME OF THE FIRST PUBLICATION OF THIS NOTICE OR 30 DAYS AFTER THE DATE OF SERVICE OF A COPY OF THIS NOTICE ON THEM.
 All other creditors of the decedent and other persons having claims or demands against decedent's estate must file their claims with this court WITHIN 3 MONTHS AFTER THE DATE OF THE FIRST PUBLICATION OF THIS NOTICE.
 ALL CLAIMS NOT FILED WITHIN THE TIME PERIODS SET FORTH IN SECTION 733.702 OF THE FLORIDA PROBATE CODE WILL BE FOREVER BARRED.
 NOTWITHSTANDING THE TIME PERIODS SET FORTH ABOVE, ANY CLAIM FILED TWO (2) YEARS OR MORE AFTER THE DECEDENT'S DATE OF DEATH IS BARRED.
 The date of first publication of this notice is September 27, 2024.
Personal Representative
Garth Hall
 B3521 Environ Blvd
 Lauderhill, FL 33319
 Attorney for Personal Representative
 Ileana Ruiz Zapico, Esq.
 Florida Bar No.: 317550
 Ileana Ruiz Zapico, P.A.
 9700 South Dixie Highway, Suite 660
 Miami, FL 33156
 Phone: (305) 412-9356
 Fax: (866) 390-9710
 Email: irzapico@zapicolaw.net
 Sept. 27; Oct. 4, 2024 24-04235L

FIRST INSERTION
NOTICE TO CREDITORS
 IN THE CIRCUIT COURT OF THE TWENTIETH JUDICIAL CIRCUIT IN AND FOR LEE COUNTY, FLORIDA
 PROBATE DIVISION
File No. 24-CP-002844
IN RE: ESTATE OF JANICE MARIE KOSTER, aka JANICE M. KOSTER Deceased.
 The administration of the estate of JANICE MARIE KOSTER, also known as JANICE M. KOSTER, deceased, whose date of death was August 30, 2023, is pending in the Circuit Court for Lee County, Florida, Probate Division, the address of which is 2075 Dr. Martin Luther King Jr. Blvd., Fort Myers, FL 33901. The names and addresses of the personal representative and the personal representative's attorney are set forth below.
 All creditors of the decedent and other persons having claims or demands against decedent's estate, on whom a copy of this notice is required to be served, must file their claims with this court ON OR BEFORE THE LATER OF 3 MONTHS AFTER THE TIME OF THE FIRST PUBLICATION OF THIS NOTICE OR 30 DAYS AFTER THE DATE OF SERVICE OF A COPY OF THIS NOTICE ON THEM.
 All other creditors of the decedent and other persons having claims or demands against decedent's estate must file their claims with this court WITHIN 3 MONTHS AFTER THE DATE OF THE FIRST PUBLICATION OF THIS NOTICE.
 ALL CLAIMS NOT FILED WITHIN THE TIME PERIODS SET FORTH IN FLORIDA STATUTES SECTION 733.702 WILL BE FOREVER BARRED.
 NOTWITHSTANDING THE TIME PERIOD SET FORTH ABOVE, ANY CLAIM FILED TWO (2) YEARS OR MORE AFTER THE DECEDENT'S DATE OF DEATH IS BARRED.
 The date of first publication of this notice is: September 27, 2024.
Personal Representative:
/s/ Laura Giacomino
(Sep 19, 2024 14:11 CDT)
LAURA R. GIACOMINO
 321 N. Ferndale Ave.
 Elmhurst, IL 60126
 Attorney for Personal Representative:
 /s/ Theresa Daniels
 THERESA DANIELS, ESQ.
 Daniels Law, P.A.
 P.O. Box 570
 Bokeria, FL 33922
 (239) 214-6010
 tad@DanielsLawPA.com
 jenn@danielslawpa.com
 Attorney for Personal Representative
 Sept. 27; Oct. 4, 2024 24-04230L

FIRST INSERTION
NOTICE TO CREDITORS
 IN THE CIRCUIT COURT OF THE TWENTIETH JUDICIAL CIRCUIT IN AND FOR LEE COUNTY, FL PROBATE DIVISION
FILE NO.: 2024-CP-001318
JUDGE: MCHUGH
IN RE: ESTATE OF JOHN BARRETT TEETS DECEASED.
 The administration of the Estate of JOHN BARRETT TEETS (the "Decedent") whose date of death was March 4, 2024, is pending in the Circuit Court for Lee County, Florida, Probate Division, the address of which is 1700 Monroe Street, Fort Myers, FL 33901. The name and address of the Personal Representative and the Personal Representative's attorney are set forth below.
 All creditors of the Decedent and other persons having claims or demands against Decedent's estate, on whom a copy of this notice is required to be served, must file their claims with this Court ON OR BEFORE THE LATER OF 3 MONTHS AFTER THE TIME OF THE FIRST PUBLICATION OF THIS NOTICE OR 30 DAYS AFTER THE DATE OF SERVICE OF A COPY OF THIS NOTICE ON THEM.
 All other creditors of the Decedent and other persons having claims or demands against Decedent's estate must file their claims with this Court WITHIN 3 MONTHS AFTER THE DATE OF THE FIRST PUBLICATION OF THIS NOTICE.
 ALL CLAIMS NOT FILED WITHIN THE TIME PERIODS SET FORTH IN §733.702, Fla. Stat. (2024) WILL BE FOREVER BARRED.
 NOTWITHSTANDING THE TIME PERIOD SET FORTH ABOVE, ANY CLAIM FILED TWO (2) YEARS OR MORE AFTER THE DECEDENT'S DATE OF DEATH IS BARRED.
 The date of first publication of this notice is September 27, 2024.
PERSONAL REPRESENTATIVE
JOHN CHRISTOPHER TEETS
 34503 Upper Bear Creek Rd.
 Evergreen, CO 80439
 QUARLES & BRADY LLP
 JOHN R. WOOD, ESQ.
 Florida Bar No.: 1028947
 1395 Panther Lane, Suite 300
 Naples, Florida 34109
 Telephone: (239) 434-4924
 Fax: (239) 213-5460
 E-Mail: john.wood@quarles.com
 Secondary E-Mail: lisa.brown@quarles.com
 QB\92328422.1
 Sept. 27; Oct. 4, 2024 24-04261L

FIRST INSERTION
NOTICE TO CREDITORS
 IN THE CIRCUIT COURT OF THE TWENTIETH JUDICIAL CIRCUIT IN AND FOR LEE COUNTY, FLORIDA
 PROBATE DIVISION
Case No.: 24-CP-2057
IN RE: ESTATE OF EDWARD J. LEVAR, Deceased.
 The administration of the estate of EDWARD J. LEVAR, deceased, whose date of death was August 30, 2023, is pending in the Circuit Court for Lee County, Florida, Probate Division, the address of which is 1700 Monroe Street, Fort Myers, FL 33901. The names and addresses of the personal representative and the personal representative's attorney are set forth below.
 All creditors of the decedent and other persons having claims or demands against decedent's estate on whom a copy of this notice is required to be served must file their claims with this court ON OR BEFORE THE LATER OF 3 MONTHS AFTER THE TIME OF THE FIRST PUBLICATION OF THIS NOTICE OR 30 DAYS AFTER THE DATE OF SERVICE OF A COPY OF THIS NOTICE ON THEM.
 All other creditors of the decedent and other persons having claims or demands against decedent's estate must file their claims with this court WITHIN 3 MONTHS AFTER THE DATE OF THE FIRST PUBLICATION OF THIS NOTICE.
 ALL CLAIMS NOT FILED WITHIN THE TIME PERIODS SET FORTH IN FLORIDA STATUTES SECTION 733.702 WILL BE FOREVER BARRED.
 NOTWITHSTANDING THE TIME PERIODS SET FORTH ABOVE, ANY CLAIM FILED TWO (2) YEARS OR MORE AFTER THE DECEDENT'S DATE OF DEATH IS BARRED.
 The date of first publication of this notice is September 27, 2024.
Personal Representative:
/s/ Laura Giacomino
(Sep 19, 2024 14:11 CDT)
LAURA R. GIACOMINO
 321 N. Ferndale Ave.
 Elmhurst, IL 60126
 Attorney for Personal Representative:
 /s/ Theresa Daniels
 THERESA DANIELS, ESQ.
 Daniels Law, P.A.
 P.O. Box 570
 Bokeria, FL 33922
 (239) 214-6010
 tad@DanielsLawPA.com
 jenn@danielslawpa.com
 Attorney for Personal Representative
 Sept. 27; Oct. 4, 2024 24-04230L

Q&A
 Who benefits from legal notices?
 You do. Legal notices are required because a government body or corporation wants to take action that can affect individuals and the public at large.
 When the government is about to change your life, or your property or assets are about to be taken, public notices in newspapers serve to alert those affected.

--- ESTATE ---

FIRST INSERTION

NOTICE TO CREDITORS
IN THE TWENTIETH JUDICIAL
CIRCUIT IN AND FOR LEE
COUNTY, FLORIDA
PROBATE DIVISION
File No. 24-CP-002736
Probate Division
IN RE: ESTATE OF
DOUGLAS TRISSILLAN EWING,
II, aka DOUGLAS T. EWING, II, aka
DOUGLAS T. EWING,
Deceased.

The administration of the estate of Douglas Trissillan Ewing, II, aka Douglas T. Ewing, II, aka Douglas T. Ewing, deceased, whose date of death was August 6, 2024, is pending in the Circuit Court for Lee County, Florida, Probate Division, the address of which P.O. Box 9346, Fort Myers, FL 33902. The names and addresses of the personal representatives and the personal representative's attorney are set forth below.

All creditors of the decedent and other persons having claims or demands against decedent's estate on whom a copy of this notice is required to be served must file their claims with this court ON OR BEFORE THE LATER OF 3 MONTHS AFTER THE TIME OF THE FIRST PUBLICATION OF THIS NOTICE OR 30 DAYS AFTER THE DATE OF SERVICE OF A COPY OF THIS NOTICE ON THEM.

All other creditors of the decedent and other persons having claims or demands against decedent's estate must file their claims with this court WITHIN 3 MONTHS AFTER THE DATE OF THE FIRST PUBLICATION OF THIS NOTICE.

ALL CLAIMS NOT FILED WITHIN THE TIME PERIODS SET FORTH IN FLORIDA STATUTES SECTION 733.702 WILL BE FOREVER BARRED.

NOTWITHSTANDING THE TIME PERIODS SET FORTH ABOVE, ANY CLAIM FILED TWO (2) YEARS OR MORE AFTER THE DECEDENT'S DATE OF DEATH IS BARRED.

The date of first publication of this notice is September 27, 2024.

Personal Representative:

Diane C. Ewing
24380 Pennyroyal Drive
Bonita Springs, FL 34134
Attorney for Personal Representative:
Donna M. Flammang,
Attorney for Personal Representative
Florida Bar Number: 015230
Brennan, Manna & Diamond, PL
8891 Brighton Lane, Suite 112
Bonita Springs, FL 34135
P: 239.405.8672;
F: 239.390.1920
Email: dmflammang@bmdpl.com
Secondary Email:
acroczo@bmdpl.com
4867-6428-6438, v.1
Sept. 27; Oct. 4, 2024 24-04246L

FIRST INSERTION

NOTICE TO CREDITORS
IN THE CIRCUIT COURT FOR THE
TWENTIETH JUDICIAL CIRCUIT
IN AND FOR LEE COUNTY,
FLORIDA
File No. 24 CP 002749
Probate Division
IN RE: ESTATE OF
PATRICIA A. TANGUSSO,
deceased.

The administration of the testate estate of Patricia A. Tangusso, deceased, whose date of death was July 22, 2024, File Number 24 CP 002749 is pending in the Circuit Court for Lee County, Florida, Probate Division, the address of which is Lee County Justice Center, 1700 Monroe Street, 1st Floor, P.O. Box 9346, Fort Myers, FL 33902. The name and address of the personal representative and the personal representative's attorney are set forth below.

ALL INTERESTED PERSONS ARE NOTIFIED THAT:

All creditors of the decedent and other persons having claims or demands against decedent's estate on whom a copy of this Notice is served must file their claims with this Court WITHIN THE LATER OF THREE MONTHS AFTER THE DATE OF THE FIRST PUBLICATION OF THIS NOTICE OR THIRTY DAYS AFTER THE DATE OF SERVICE OF A COPY OF THIS NOTICE ON THEM.

All other creditors of the decedent and persons having claims or demands against the decedent's estate must file their claims with this Court WITHIN THREE MONTHS AFTER THE DATE OF THE FIRST PUBLICATION OF THIS NOTICE.

ALL CLAIMS NOT SO FILED WILL BE FOREVER BARRED.

NOTWITHSTANDING THE TIME PERIODS SET FORTH ABOVE, ANY CLAIM FILED TWO YEARS OR MORE AFTER THE DECEDENT'S DATE OF DEATH IS BARRED.

The date of the first publication of this Notice to Creditors is September 27, 2024

Gregory Dexter

Personal Representative
4316 Fauquier Avenue
Richmond, VA 23277
Brian J. Downey, Esq.
FL Bar Number: 0017975
BARRETT MCNAGNY LLP
Attorney for Personal Representative
215 E. Berry Street
Fort Wayne, IN 46802
(260) 423-8874
Sept. 27; Oct. 4, 2024 24-04267L

FIRST INSERTION

NOTICE TO CREDITORS
IN THE CIRCUIT COURT FOR LEE
COUNTY, FLORIDA
PROBATE DIVISION
File No. 2024-CP-001914
IN RE: ESTATE OF
DOUGLAS BANNING,
Deceased.

The administration of the estate of DOUGLAS BANNING, deceased, whose date of death was OCTOBER 18, 2021, is pending in the Circuit Court for LEE County, Florida, Probate Division, the address of which is 1700 MONROE ST., FORT MYERS, FL 33901. The names and addresses of the personal representative and the personal representative's attorney are set forth below.

All creditors of the decedent and other persons having claims or demands against decedent's estate, on whom a copy of this notice is required to be served, must file their claims with this court ON OR BEFORE THE LATER OF 3 MONTHS AFTER THE TIME OF THE FIRST PUBLICATION OF THIS NOTICE OR 30 DAYS AFTER THE DATE OF SERVICE OF A COPY OF THIS NOTICE ON THEM.

All other creditors of the decedent and other persons having claims or demands against decedent's estate must file their claims with this court WITHIN 3 MONTHS AFTER THE DATE OF THE FIRST PUBLICATION OF THIS NOTICE.

ALL CLAIMS NOT FILED WITHIN THE TIME PERIODS SET FORTH IN FLORIDA STATUTES SECTION 733.702 WILL BE FOREVER BARRED.

NOTWITHSTANDING THE TIME PERIOD SET FORTH ABOVE, ANY CLAIM FILED TWO (2) YEARS OR MORE AFTER THE DECEDENT'S DATE OF DEATH IS BARRED.

A Personal Representative or curator has no duty to discover whether any property held at the time of the decedent's death by the decedent or the decedent's surviving spouse is property to which the Florida Uniform Disposition of Community Property Rights at Death Act as described in ss. 732.216-732.228, applies, or may apply, unless a written demand is made by a creditor as specified under s. 732.2211.

The date of first publication of this notice is: September 27, 2024.

MATTHEW MCCONNELL

Personal Representative
809 Walkerbilt Road, Suite 6
Naples, FL 34110
MATTHEW MCCONNELL, Esq.
Attorney for Personal Representative
Florida Bar No. 126161
Dickman Law Firm
P.O. Box 111868
Naples, FL 34108
T: 239-434-0840
F: 239-434-0940
matthew@dickmanlawfirm.org
Sept. 27; Oct. 4, 2024 24-04248L

FIRST INSERTION

NOTICE OF FORECLOSURE SALE
IN THE CIRCUIT COURT FOR THE
TWENTIETH JUDICIAL CIRCUIT
IN AND FOR LEE COUNTY,
FLORIDA
CIRCUIT CIVIL DIVISION
CASE NO.: 24-CA-000286
NEW AMERICAN FUNDING, LLC
Plaintiff(s), vs.
MARTIN AUGUSTINE HOLLAND,
ESQ.; RIVER GARDEN, INC., A
CONDOMINIUM
Defendant(s).

NOTICE IS HEREBY GIVEN THAT, pursuant to Plaintiff's Final Judgment of Foreclosure entered on September 19, 2024 in the above-captioned action, the Clerk of Court will sell to the highest and best bidder for cash at www.lee.realforeclose.com in accordance with Chapter 45, Florida Statutes on the 24th day of October, 2024 at 09:00 AM on the following described property as set forth in said Final Judgment of Foreclosure or order, to wit:

THE FOLLOWING DESCRIBED PROPERTY LOCATED IN THE COUNTY OF LEE, FLORIDA: UNIT 26-B, OF RIVER GARDEN, INC., A CONDOMINIUM ACCORDING TO THE DECLARATION OF CONDOMINIUM THEREOF RECORDED IN OFFICIAL RECORDS BOOK 335, PAGE 359, OF THE PUBLIC RECORDS OF LEE COUNTY, FLORIDA, AND ALL AMENDMENTS THERETO, TOGETHER WITH ITS UNDIVIDED SHARE IN THE COMMON ELEMENTS.

Property address: 3225 East Riverside Drive, 26b, Fort Myers, FL 33916

Any person claiming an interest in the surplus from the sale, if any, other than the property owner as of the date of the lis pendens, must file a claim before the clerk reports the surplus as unclaimed.

09/23/2024

Kevin Karnes
CLERK OF THE CIRCUIT COURT
As Clerk of the Court
(SEAL) BY: N. Watson
Deputy Clerk
Padgett Law Group,
Attorney for Plaintiff
6267 Old Water Oak Road, Suite 203
Tallahassee, FL 32312
attorney@padgettlawgroup.com
TDP File No. 23-011740-1
Sept. 27; Oct. 4, 2024 24-04245L

FIRST INSERTION

NOTICE TO CREDITORS
IN THE CIRCUIT COURT FOR LEE
COUNTY, FLORIDA
PROBATE DIVISION
File No. 24-CP-2866
Division: Probate
IN RE: ESTATE OF
FRANCIS B. SPELLANE
Deceased.

The administration of the estate of Francis B. Spellane, deceased, whose date of death was August 10, 2024, is pending in the Circuit Court for LEE County, Florida, Probate Division, the address of which is P. O. Box 9346, Fort Myers, FL 33902. The names and addresses of the personal representative and the personal representative's attorney are set forth below.

All creditors of the decedent and other persons having claims or demands against decedent's estate on whom a copy of this notice is required to be served must file their claims with this court ON OR BEFORE THE LATER OF 3 MONTHS AFTER THE TIME OF THE FIRST PUBLICATION OF THIS NOTICE OR 30 DAYS AFTER THE DATE OF SERVICE OF A COPY OF THIS NOTICE ON THEM.

The personal representative has no duty to discover whether any property held at the time of the decedent's death by the decedent or the decedent's surviving spouse is property to which the Florida Uniform Disposition of Community Property Rights at Death Act as described in ss. 732.216-732.228, Florida Statutes, applies, or may apply, unless a written demand is made by a creditor as specified under s. 732.2211, Florida Statutes.

All other creditors of the decedent and other persons having claims or demands against decedent's estate must file their claims with this court WITHIN 3 MONTHS AFTER THE DATE OF THE FIRST PUBLICATION OF THIS NOTICE.

ALL CLAIMS NOT FILED WITHIN THE TIME PERIODS SET FORTH IN FLORIDA STATUTES SECTION 733.702 WILL BE FOREVER BARRED.

NOTWITHSTANDING THE TIME PERIODS SET FORTH ABOVE, ANY CLAIM FILED TWO (2) YEARS OR MORE AFTER THE DECEDENT'S DATE OF DEATH IS BARRED.

The date of first publication of this notice is September 27, 2024.

Mary Jo Barry

7200 Coventry Court, Unit 112
Naples, Florida 34104
Attorney for Personal Representative:
Hayley E. Donaldson, Attorney
Florida Bar Number: 1002236
Sheppard Law Firm
9100 College Pointe Court
Fort Myers, FL 33919
Telephone: (239) 334-1141
Fax: (239) 334-3965
E-Mail: donaldson@sbslaw.com
Secondary E-Mail:
bmerhige@sbslaw.com
Sept. 27; Oct. 4, 2024 24-04251L

FIRST INSERTION

NOTICE OF FORECLOSURE SALE
IN THE CIRCUIT COURT OF THE
TWENTIETH JUDICIAL CIRCUIT
IN AND FOR LEE COUNTY,
FLORIDA
CASE NO.: 23-CA-010769
LAKEVIEW LOAN SERVICING,
LLC,
Plaintiff, v.
GEORGE CODY KERR, et al.,
Defendants.

NOTICE is hereby given that Kevin C. Karnes, Clerk of the Circuit Court of Lee County, Florida, will on October 24, 2024, at 9:00 a.m. ET, via the online auction site at www.lee.realforeclose.com in accordance with Chapter 45, F.S., offer for sale and sell to the highest and best bidder for cash, the following described property situated in Lee County, Florida, to wit:

Lots 19 and 20, Block 2679, CAPE CORAL UNIT 38, according to plat thereof as recorded in Plat Book 16, Page 87 of the Public Records of Lee County, Florida.
Property Address: 1211 NW 1st Place, Cape Coral, FL 33993

pursuant to the Final Judgment of Foreclosure entered in a case pending in said Court, the style and case number of which is set forth above.

Any person claiming an interest in the surplus from the sale, if any, other than the property owner as of the date of the Lis Pendens must file a claim before the clerk reports the surplus as unclaimed.

If the sale is set aside for any reason, the Purchaser at the sale shall be entitled only to a return of the deposit paid. The Purchaser shall have no further recourse against the Mortgagee, the Mortgagee or the Mortgagee's attorney. WITNESS my hand and official seal of this Honorable Court this day of 09/24/2024

Kevin C. Karnes
Clerk of the Circuit Court
(SEAL) By: N. Watson
DEPUTY CLERK
Tiffany & Bosco, P.A.
1201 S. Orlando Ave., Suite 430
Winter Park, FL 32789
floridaservice@tblaw.com
Sept. 27; Oct. 4, 2024 24-04256L

FIRST INSERTION

NOTICE TO CREDITORS
IN THE CIRCUIT COURT FOR LEE
COUNTY, FLORIDA
PROBATE DIVISION
File No. 24-CP-2899
Division: Probate
IN RE: ESTATE OF
PETER PALA
Deceased.

The administration of the estate of Peter Pala, deceased, whose date of death was July 13, 2024, is pending in the Circuit Court for Lee County, Florida, Probate Division, the address of which is P.O. Box 9346, Fort Myers, FL 33902. The names and addresses of the personal representative and the personal representative's attorney are set forth below.

All creditors of the decedent and other persons having claims or demands against decedent's estate on whom a copy of this notice is required to be served must file their claims with this court ON OR BEFORE THE LATER OF 3 MONTHS AFTER THE TIME OF THE FIRST PUBLICATION OF THIS NOTICE OR 30 DAYS AFTER THE DATE OF SERVICE OF A COPY OF THIS NOTICE ON THEM.

The personal representative has no duty to discover whether any property held at the time of the decedent's death by the decedent or the decedent's surviving spouse is property to which the Florida Uniform Disposition of Community Property Rights at Death Act as described in ss. 732.216-732.228, Florida Statutes, applies, or may apply, unless a written demand is made by a creditor as specified under s. 732.2211, Florida Statutes.

All other creditors of the decedent and other persons having claims or demands against decedent's estate must file their claims with this court WITHIN 3 MONTHS AFTER THE DATE OF THE FIRST PUBLICATION OF THIS NOTICE.

ALL CLAIMS NOT FILED WITHIN THE TIME PERIODS SET FORTH IN FLORIDA STATUTES SECTION 733.702 WILL BE FOREVER BARRED.

NOTWITHSTANDING THE TIME PERIODS SET FORTH ABOVE, ANY CLAIM FILED TWO (2) YEARS OR MORE AFTER THE DECEDENT'S DATE OF DEATH IS BARRED.

The date of first publication of this notice is September 27, 2024.

Paula M. Pala

17412 Via Lugano Court
Miromar Lakes, Florida 33913
Attorney for Personal Representative:
Douglas A. Dodson, II
Florida Bar Number: 126439
DORCEY LAW FIRM PLC
10181 Six Mile Parkway, Ste C
Fort Myers, FL 33966
Telephone: (239) 418-0169
Fax: (239) 418-0048
E-Mail: douglas@dorceylaw.com
Secondary E-Mail:
probate@dorceylaw.com
Sept. 27; Oct. 4, 2024 24-04262L

FIRST INSERTION

NOTICE OF SALE
IN THE CIRCUIT COURT OF THE
TWENTIETH JUDICIAL CIRCUIT
IN AND FOR LEE COUNTY,
FLORIDA
CASE NO. 24-CA-001116
MIDFIRST BANK
Plaintiff, v.
SASSON RODRIGUEZ A/K/A
SASSON RODRIGUEZ; GIOVANY
RODRIGUEZ; UNKNOWN
TENANT 1; UNKNOWN TENANT
2; UNITED STATES OF AMERICA
DEPARTMENT OF HOUSING AND
URBAN DEVELOPMENT
Defendants.

Notice is hereby given that, pursuant to the Final Judgment of Foreclosure entered on September 19, 2024, in this cause, in the Circuit Court of Lee County, Florida, the clerk shall sell the property situated in Lee County, Florida, described as:

LOTS 52 AND 53, BLOCK 1882, CAPE CORAL SUBDIVISION, UNIT 45, PART 1, ACCORDING TO THE MAP OR PLAT THEREOF, AS RECORDED IN PLAT BOOK 21, PAGES 135 THROUGH 150, OF THE PUBLIC RECORDS OF LEE COUNTY, FLORIDA.
a/k/a 529 SW 25TH LN, CAPE CORAL, FL 33914-7706

at public sale, to the highest and best bidder, for cash, online at www.lee.realforeclose.com, on October 31, 2024 beginning at 09:00 AM.

Any person claiming an interest in the surplus from the sale, if any, other than the property owner as of the date of the lis pendens must file a claim before the clerk reports the surplus as unclaimed.

Dated this day of 09/24/2024
Kevin C. Karnes
Clerk of the Circuit Court
(SEAL) By: N. Watson
Deputy Clerk

eXL Legal, PLLC
12425 28TH ST NORTH, STE. 200
ST. PETERSBURG, FL 33716-1826
EFILING@EXLEGAL.COM
1000008916
Sept. 27; Oct. 4, 2024 24-04266L

FIRST INSERTION

NOTICE OF ACTION
IN THE CIRCUIT COURT OF THE
TWENTIETH JUDICIAL CIRCUIT
IN AND FOR LEE COUNTY,
FLORIDA
CIVIL ACTION
Case No. 24-CC-006256
JMK LLC, a Wyoming limited
liability company,
Plaintiff, v.
THE UNKNOWN HEIRS OF
JOSEPH KLUG; THE UNKNOWN
HEIRS OF ILONA KLUG; LUCILLE
P. CUNNINGHAM; MARYAM H.
O. S. ALHOULAH; MUNA H. A.
M. H. ALSAYEGH; and all others
claiming by, through or under these
Defendants,
Defendants.

TO: THE UNKNOWN HEIRS OF JOSEPH KLUG

Last Known Addresses: 7061 S. Tamiami Trl, Apt. 110, Sarasota, FL 34231-5559

YOU ARE NOTIFIED that an action to quiet title on the following property in Lee County, Florida:

Lot 18, Block 37, Unit 10, Section 14, Township 44 South, Range 27 East, Lehigh Acres, according to the map or plat thereof on file in the Office of the Clerk of the Circuit Court, recorded in Plat Book 15, Page 16, Public Records of Lee County, Florida.
Address: 1511 Wellington Avenue, Leigh Acres, FL 33972
Parcel ID: 14-44-27-L2-10037.0180
(the "Property").

has been filed against you and you are required to serve a copy of your writ-

FIRST INSERTION

NOTICE TO CREDITORS
IN THE CIRCUIT COURT FOR LEE
COUNTY, FLORIDA
PROBATE DIVISION
File No. 24-CP-002814
IN RE: ESTATE OF
LORRAINE M. KELLOGG
a/k/a LORRAINE MAE KELLOGG
a/k/a LORRAINE KELLOGG
a/k/a LORRAINE MAE PICK
Deceased.

The administration of the estate of Lorraine M. Kellogg, deceased, whose date of death was March 4, 2024, is pending in the Circuit Court for Lee County, Florida, Probate Division, the address of which is Justice Center, 2nd Floor, 2075 Dr. Martin Luther King Jr. Boulevard, Fort Myers, Florida 33901. The names and addresses of the ancillary personal representative and the ancillary personal representative's attorney are set forth below.

All creditors of the decedent and other persons having claims or demands against decedent's estate on whom a copy of this notice is required to be served must file their claims with this court ON OR BEFORE THE LATER OF 3 MONTHS AFTER THE TIME OF THE FIRST PUBLICATION OF THIS NOTICE OR 30 DAYS AFTER THE DATE OF SERVICE OF A COPY OF THIS NOTICE ON THEM.

All other creditors of the decedent and other persons having claims or demands against decedent's estate must file their claims with this court WITHIN 3 MONTHS AFTER THE DATE OF THE FIRST PUBLICATION OF THIS NOTICE.

FIRST INSERTION

NOTICE TO CREDITORS
IN THE CIRCUIT COURT FOR LEE
COUNTY, FLORIDA
PROBATE DIVISION
File No. 24-CP-2516
IN RE: ESTATE OF
MICHAEL S. KITCHURA
Deceased.

The administration of the estate of Michael S. Kitchura, deceased, whose date of death was May 13, 2024, is pending in the Circuit Court for Lee County, Florida, Probate Division, the address of which is P.O. Box 9346, Fort Myers, FL 33902. The names and addresses of the personal representatives and the personal representatives' attorney are set forth below.

All creditors of the decedent and other persons having claims or demands against decedent's estate on whom a copy of this notice is required to be served must file their claims with this court ON OR BEFORE THE LATER OF 3 MONTHS AFTER THE TIME OF THE FIRST PUBLICATION OF THIS NOTICE OR 30 DAYS AFTER THE DATE OF SERVICE OF A COPY OF THIS NOTICE ON THEM.

The personal representatives have no duty to discover whether any property held at the time of the decedent's death by the decedent or the decedent's surviving spouse is property to which the Florida Uniform Disposition of Community Property Rights at Death Act as described in ss. 732.216-732.228, Florida Statutes, applies, or may apply, unless a written demand is made by a creditor as specified under s. 732.2211, Florida Statutes.

All other creditors of the decedent

ten defenses by the Lee County Clerk of Court's scheduled default date of October 30, 2024 on Bradley W. Butcher, Plaintiff's attorney, whose address is 6830 Porto Fino Circle, Ste. 2, Fort Myers, Florida 33912 and file the original with this Court either before service on Plaintiff's attorney, or immediately thereafter; otherwise a default will be entered against you for the relief demanded in the Complaint or petition.

This notice shall be published once a week for four (4) consecutive weeks in the Gulf Coast Business Review.

If you are a person with a disability who needs any accommodation in order to participate in this proceeding, you are entitled, at no cost to you, to the provision of certain assistance. Please contact Brooke Dean, Operations Division Manager, whose office is located at Lee County Justice Center, 1700 Monroe Street, Fort Myers, Florida 33901, and whose telephone number is (239) 533-1771, at least 7 days before your scheduled court appearance, or immediately upon receiving this notification if the time before the scheduled appearance is less than 7 days; if you are hearing or voice impaired, call 711.

Dated this 20th day of September, 2024.

CLERK OF THE CIRCUIT COURT
KEVIN C. KARNES
Lee County Clerk of Court
(SEAL) By: K. Harris
as Deputy Clerk

Butcher & Associates, P.L.
6830 Porto Fino Circle, Ste. 2
Fort Myers, Florida 33912
Sept. 27; Oct. 4, 11, 18, 2024
24-04236L

FIRST INSERTION

NOTICE.
The personal representative has no duty to discover whether any property held at the time of the decedent's death by the decedent or the decedent's surviving spouse is property to which the Florida Uniform Disposition of Community Property Rights at Death Act as described in ss. 732.216-732.228, applies, or may apply, unless a written demand is made by a creditor as specified under s. 732.2211, Florida Statutes.

ALL CLAIMS NOT FILED WITHIN THE TIME PERIODS SET FORTH IN FLORIDA STATUTES SECTION 733.702 WILL BE FOREVER BARRED.

NOTWITHSTANDING THE TIME PERIODS SET FORTH ABOVE, ANY CLAIM FILED TWO (2) YEARS OR MORE AFTER THE DECEDENT'S DATE OF DEATH IS BARRED.

The date of first publication of this notice is September 27, 2024.

Ancillary Personal Representative:
Kathryn E. Moser

50761 County Road 126
Salol, Minnesota 56756
Attorney for Ancillary Personal Representative:
Eric S. Kane, Esquire
E-mail Addresses:
eric@kanelawpl.com
Florida Bar No. 0847941
Eric S. Kane, P.L.
20900 N.E. 30th Avenue, Suite 403
Aventura, Florida 33180
Telephone: (305) 937-7280
Sept. 27; Oct. 4, 2024 24-04250L

FIRST INSERTION

and other persons having claims or demands against decedent's estate must file their claims with this court WITHIN 3 MONTHS AFTER THE DATE OF THE FIRST PUBLICATION OF THIS NOTICE.

ALL CLAIMS NOT FILED WITHIN THE TIME PERIODS SET FORTH IN FLORIDA STATUTES SECTION 733.702 WILL BE FOREVER BARRED.

NOTWITHSTANDING THE TIME PERIODS SET FORTH ABOVE, ANY CLAIM FILED TWO (2) YEARS OR MORE AFTER THE DECEDENT'S DATE OF DEATH IS BARRED.

The date of first publication of this notice is September 27, 2024.

Personal Representatives:
Thomas Vasilou

3115 SE 10th Place
Cape Coral, FL 33904
Catherine Ancefsky
6908 Marbrook Court
Fort Myers, FL 33919

Attorney for Personal Representatives:
/s/ Courtney Lovejoy,
Bar No. 1010542, for
Beth A. Prather, Esq., Attorney
Florida Bar Number: 974962
Green Schoenfeld & Kyle LLP
1380 Royal Palm Square Boulevard
Fort Myers, Florida 33919
Telephone: (239) 936-7200
Fax: (239) 936-7997
E-Mail:
courtneylovejoy@gskattorneys.com
Secondary E-Mail:
melissahill@gskattorneys.com
01009200.DOCX/1
Sept. 27; Oct. 4, 2024 24-04260L

PUBLISH YOUR LEGAL NOTICE
Email: legal@businessobserverfl.com
Business Observer

--- ACTIONS / SALES ---

FIRST INSERTION

NOTICE OF SALE
IN THE CIRCUIT CIVIL COURT OF THE TWENTIETH JUDICIAL CIRCUIT OF FLORIDA, IN AND FOR LEE COUNTY CIVIL DIVISION
Case No. 36-2022-CA-000685
Division G

U.S. BANK TRUST NATIONAL ASSOCIATION, NOT IN ITS INDIVIDUAL CAPACITY BUT SOLELY AS OWNER TRUSTEE FOR RCF 2 ACQUISITION TRUST Plaintiff, vs. ADELE VAN DEN BERG, AS GUARDIAN FOR CRAIG VANDENBERG, INCAPACITATED, SHERYL VANDERBERG A/K/A SHERYL VANDENBERG, GLADIOLUS PRESERVE HOMEOWNERS ASSOCIATION, INC., MORTGAGE ELECTRONIC REGISTRATION SYSTEMS, INC. AS NOMINEE FOR CITIBANK FEDERAL SAVINGS BANK, SUNCOAST CREDIT UNION, AND UNKNOWN TENANTS/OWNERS, Defendants.

Notice is hereby given, pursuant to Final Judgment of Foreclosure for Plaintiff entered in this cause on February 16, 2023, in the Circuit Court of Lee County, Florida, Kevin C. Karnes, Clerk of the Circuit Court, will sell the property situated in Lee County, Florida described as:

LOT 61, GLADIOLUS PRESERVE, ACCORDING TO THE PLAT THEREOF, AS RECORDED IN PLAT BOOK 73, PAGE(S) 58 THROUGH 63, INCLUSIVE, OF THE PUBLIC RECORDS OF LEE COUNTY, FLORIDA.

and commonly known as: 9010 GLADIOLUS PRESERVE C, FT MYERS, FL 33908; including the building, appurtenances, and fixtures located therein, at public sale, to the highest and best bidder, for cash, at: www.lee.realforeclose.com on OCTOBER 17, 2024 at 9:00 a.m.

Any persons claiming an interest in the surplus from the sale, if any, other than the property owner as of the date of the lis pendens must file a claim before the clerk reports the surplus as unclaimed.

Dated this day of 09/20/2024,
Clerk of the Circuit Court
Kevin C. Karnes
(SEAL) By: N. Watson
Deputy Clerk

Jennifer M. Scott
(813) 229-0900 x
Kass Shuler, P.A.
1505 N. Florida Ave.
Tampa, FL 33602-2613
ForeclosureService@kasslaw.com
318000/1912522/wll
Sept. 27; Oct. 4, 2024 24-04215L

FIRST INSERTION

NOTICE OF ACTION
IN THE CIRCUIT COURT OF THE TWENTIETH JUDICIAL CIRCUIT OF FLORIDA IN AND FOR LEE COUNTY
GENERAL JURISDICTION DIVISION

CASE NO. 24-CA-004660
ISHARPE OPPORTUNITY INTERMEDIATE FUND L.P., Plaintiff, vs. FORT MYERS ENTERPRISES, LLC; ERICK AMARAL; UNKNOWN TENANT IN POSSESSION 1; and UNKNOWN TENANT IN POSSESSION 2, Defendants.

To: ERICK AMARAL
7803 SW 193rd Street
Cutler Bay, Florida 33157
LAST KNOWN ADDRESS STATED.
YOU ARE HEREBY NOTIFIED that an action to foreclose Mortgage covering the following real and personal property described as follows, to-wit

LOTS 13 & 14, BLOCK 615, UNIT 21, CAPE CORAL SUBDIVISION, ACCORDING TO THE PLAT THEREOF, AS RECORDED IN PLAT BOOK 13, PAGE(S) 149 THROUGH 173, INCLUSIVE, OF THE PUBLIC RECORDS OF LEE COUNTY, FLORIDA.
Parcel Number: 31-44-24-C3-00615.0130.

has been filed against you and you are required to serve a copy of your written defenses, if any, to it on Charles P. Gufford, McCalla Raymer Leibert Pierce, LLC, 225 E. Robinson St. Suite 155, Orlando, FL 32801 and file the original with the Clerk of the above-styled Court within 30 days from the first publication, otherwise a Judgment may be entered against you for the relief demanded in the Complaint.

WITNESS my hand and seal of said Court on the day of 09/18/2024,
Kevin C. Karnes
CLERK OF THE CIRCUIT COURT
As Clerk of the Court
(SEAL) BY: N. Watson
Deputy Clerk

MCCALLA RAYMER LEIBERT PIERCE, LLC
225 E. Robinson St. Suite 155
Orlando, FL 32801
Phone: (407) 674-1850
Fax: (321) 248-0420
24-09577FL
Sept. 27; Oct. 4, 2024 24-04233L

FIRST INSERTION

NOTICE OF SALE PURSUANT TO CHAPTER 45
IN THE COUNTY COURT OF THE TWENTIETH JUDICIAL CIRCUIT IN AND FOR LEE COUNTY, FLORIDA
CIVIL DIVISION
Case No.: 24-CC-004148

PARKSIDE PLACE CONDOMINIUM ASSOCIATION, INC., a Florida Not-For-Profit Corporation, Plaintiff, vs. GEORGE KORMOS, and UNKNOWN TENANT, Defendants.
NOTICE IS HEREBY GIVEN pursuant to the Final Judgment of Foreclosure dated September 6, 2024 entered in Case No. 24-CC-004148, of the County Court of the Twentieth Judicial Circuit in and for Lee County, Florida, wherein PARKSIDE PLACE CONDOMINIUM ASSOCIATION, INC., a Florida Not-For-Profit Corporation is Plaintiff, and GEORGE KORMOS is a Defendant, I will sell to the highest bidder for cash on October 10, 2024, in an online sale at www.lee.realforeclose.com beginning at 9:00 a.m., the following property as set forth in said Final Judgment, to wit:

Unit No. 102, Building 2, PARKSIDE, A CONDOMINIUM, according to the Declaration recorded in O.R. Book 1777, at Page 1220, as amended, Public Records of Lee County, Florida, together with all of the appurtenances thereunto appertaining and specified in said Condominium Declaration.
Property Address: 15075 Parkside Drive, Unit 102, Fort Myers, FL 33908.

ANY PERSON CLAIMING AN INTEREST IN THE SURPLUS FROM THE SALE, IF ANY, OTHER THAN THE PROPERTY OWNER, AS OF THE DATE OF THE LIS PENDENS MUST FILE A CLAIM IN ACCORDANCE WITH FLORIDA STATUTES, SECTION 45.031.

Dated: 09/18/2024
Kevin C. Karnes
Lee Clerk of Circuit Court
(SEAL) By: N. Watson
Deputy Clerk

/s/ Bryan B. Levine, Esq.
Primary Email:
Pleadings@knoxlevine.com
Bryan B. Levine, Esq., FBN 89821
36354 U.S. 19 N.
Palm Harbor FL 34684
Main Line: (727) 223-6368;
Fax: (727) 478-4579
Sept. 27; Oct. 4, 2024 24-04234L

FIRST INSERTION

NOTICE OF FORECLOSURE SALE
IN THE COUNTY COURT OF THE TWENTIETH JUDICIAL CIRCUIT IN AND FOR LEE COUNTY, FLORIDA
DIVISION: CIVIL
CASE NO. 24-CC-004345

THE SOUTH SEAS CLUB CONDOMINIUM ASSOCIATION, INC., a Florida non-profit corporation, Plaintiff, vs. VIRGINIA MCANANY WATERMAN, INDIVIDUALLY AND AS TRUSTEE, OR SUCCESSOR IN TRUST, UNDER THE VIRGINIA MCANANY WATERMAN LIVING TRUST, DATED OCTOBER 16, 1998, Defendant(s).

NOTICE is hereby given that the undersigned, Clerk of Circuit and County Courts of Lee County, Florida, will on October 24, 2024, at 9:00 A.M. via electronic sale at www.lee.realforeclose.com, in accordance with Section 45.031, Florida Statutes, offer for sale and sell to the highest bidder for cash, the following described property situated in Lee County, Florida:

Unit Week No. 39 in Condominium Parcel Number M-II (a/k/a Unit 1310) of THE SOUTH SEAS CLUB, a Condominium according to the declaration of Condominium thereof, recorded in Official Records Book 1480 at Page 970, of the Public Records of Lee County, Florida, and all amendment thereto, if any pursuant to the Final Judgment of Lien Foreclosure entered in a case pending in said Court in the above-styled cause.
Any person claiming an interest in the surplus from the sale, if any, other than the property owner as of the date of the Lis Pendens must file a claim in accordance with Florida Statutes, Section 45.031.

WITNESS my hand and official seal of said Court this day of 09/24/2024.

KEVIN C. KARNES,
CLERK OF COURT
(SEAL) By: N. Watson
Deputy Clerk

Michael J. Belle, Esquire
Attorney for Plaintiff
2364 Fruitville Road
Sarasota, FL 34237
service@michaelbelle.com
48075 / 3-56334
Sept. 27; Oct. 4, 2024 24-04255L

FIRST INSERTION

NOTICE OF ACTION - CONSTRUCTIVE SERVICE
IN THE CIRCUIT COURT OF THE TWENTIETH JUDICIAL CIRCUIT IN AND FOR LEE COUNTY, FLORIDA
GENERAL JURISDICTION DIVISION
CASE NO. 24-CA-000825

LAKEVIEW LOAN SERVICING, LLC, Plaintiff, vs. JEMAL ALEMDAR, BRITTANY HERNANDEZ, AND THE UNKNOWN HEIRS, BENEFICIARIES, DEVISEES, GRANTEEES, ASSIGNEES, LIENORS, CREDITORS, TRUSTEES AND ALL OTHERS WHO MAY CLAIM AN INTEREST IN THE ESTATE OF BRIANA HERNANDEZ, DECEASED, et. al. Defendant(s).

TO: THE UNKNOWN HEIRS, BENEFICIARIES, DEVISEES, GRANTEEES, ASSIGNEES, LIENORS, CREDITORS, TRUSTEES AND ALL OTHERS WHO MAY CLAIM AN INTEREST IN THE ESTATE OF BRIANA HERNANDEZ, DECEASED, whose last known residence is 434 PICTURESQUE, LEHIGH ACRES, FL 33974, if he/she/they be living; and if he/she/they be dead, the unknown defendants who may be spouses, heirs, devisees, grantees, assignees, lienors, creditors, trustees, and all parties claiming an interest by, through, under or against the Defendants, who are not known to be dead or alive, and all parties having or claiming to have any right, title or interest in the property described in the mortgage being foreclosed herein.

TO: AIDEN HERNANDEZ, ANALISA HERNANDEZ, whose last known residence is 434 PICTURESQUE, LEHIGH ACRES, FL

FIRST INSERTION

NOTICE OF ACTION
IN THE CIRCUIT COURT OF THE 20TH JUDICIAL CIRCUIT, IN AND FOR LEE COUNTY, FLORIDA
CIVIL DIVISION
CASE NO.: 24-CA-005631

WINTRUST MORTGAGE, A DIVISION OF BARRINGTON BANK & TRUST COMPANY, N.A., Plaintiff, vs. UNKNOWN HEIRS, BENEFICIARIES, DEVISEES, ASSIGNEES, LIENORS, CREDITORS, TRUSTEES AND ALL OTHERS WHO MAY CLAIM AN INTEREST ON THE ESTATE OF ALTHEA TOMLINS, et al., Defendants.

TO: UNKNOWN HEIRS, BENEFICIARIES, DEVISEES, ASSIGNEES, LIENORS, CREDITORS, TRUSTEES AND ALL OTHERS WHO MAY CLAIM AN INTEREST ON THE ESTATE OF ALTHEA TOMLINS
YOU ARE NOTIFIED that an action for Foreclosure of Mortgage on the following described property:
LOTS 5 AND 6, BLOCK 2645, CAPE CORAL UNIT 38, A SUBDIVISION, ACCORDING TO THE PLAT THEREOF AS RECORDED IN PLAT BOOK 16, PAGE(S) 87 THROUGH 99, INCLUSIVE, OF THE PUBLIC RECORDS OF LEE COUNTY, FLORIDA.

has been filed against you and you are required to serve a copy of your written defenses, if any, to it, on De Cubas & Lewis, P.A., Attorney for Plaintiff,

FIRST INSERTION

NOTICE OF ACTION
IN THE CIRCUIT COURT OF THE TWENTIETH JUDICIAL CIRCUIT IN AND FOR LEE COUNTY, FLORIDA
CIVIL ACTION
CASE NO.: 24-CA-005325

CITIZENS BANK, N.A., Plaintiff, vs. MCV DREAMS LLC, A FLORIDA LIMITED LIABILITY COMPANY, et al, Defendant(s).

To: ERICK AMARAL
Last Known Address: 7803 SW 193RD STREET CUTLER BAY, FL 33157
Current Address: Unknown

YOU ARE NOTIFIED that an action to foreclose a mortgage on the following property in Lee County, Florida:
THE FOLLOWING DESCRIBED LAND IN THE COUNTY OF LEE, STATE OF FLORIDA, TO -WIT:

LOT 6, BLOCK B, CALOOSA-HATCHEE HEIGHTS, ACCORDING TO THE PLAT THEREOF AS RECORDED IN PLAT BOOK 6, PAGE 78, PUBLIC RECORDS OF LEE COUNTY, FLORIDA.
A/K/A 607-609 PRINCESS STREET FORT MYERS FL 33916

has been filed against you and you are required to file written defenses with the clerk of court and to serve a copy within 30 days after the first publica-

FIRST INSERTION

NOTICE OF ACTION
IN THE CIRCUIT COURT OF THE TWENTIETH JUDICIAL CIRCUIT IN AND FOR LEE COUNTY, FLORIDA
CIVIL ACTION
CASE NO.: 36-2024-CA-002457

BANK OF AMERICA, N.A., Plaintiff, vs. THE UNKNOWN HEIRS, DEVISEES, GRANTEEES, ASSIGNEES, LIENORS, CREDITORS, TRUSTEES, OR OTHER CLAIMANTS CLAIMING BY, THROUGH, UNDER, OR AGAINST, WAYNE G. MAGIN AKA WAYNE GORDON MAGIN AKA W.G. MAGIN, DECEASED, et al, Defendant(s).

To: THE UNKNOWN HEIRS, DEVISEES, GRANTEEES, ASSIGNEES, LIENORS, CREDITORS, TRUSTEES, OR OTHER CLAIMANTS CLAIMING BY, THROUGH, UNDER, OR AGAINST, WAYNE G. MAGIN AKA WAYNE GORDON MAGIN AKA W.G. MAGIN, DECEASED
Last Known Address: Unknown
Current Address: Unknown
THE UNKNOWN HEIRS, DEVISEES, GRANTEEES, ASSIGNEES, LIENORS, CREDITORS, TRUSTEES, OR OTHER CLAIMANTS CLAIMING BY, THROUGH, UNDER, OR AGAINST, LYNNE CONNER MAGIN, DECEASED

Last Known Address: Unknown
Current Address: Unknown
YOU ARE NOTIFIED that an action to foreclose a mortgage on the following property in Lee County, Florida:

LOT 4, BLOCK 3, FIRST AN-NEX TO PINE RUN AT THREE OAKS, BEING A REPLAT OF BLOCKS 3 AND 5 OF PINE RUN AT THREE OAKS AND PART OF THE NORTHEAST 1/4 OF SECTION 22, TOWN-

FIRST INSERTION

NOTICE OF ACTION
IN THE CIRCUIT COURT OF THE TWENTIETH JUDICIAL CIRCUIT IN AND FOR LEE COUNTY, FLORIDA
CIVIL ACTION
Case No. 24-CC-006256

JMK LLC, a Wyoming limited liability company, Plaintiff, v. THE UNKNOWN HEIRS OF JOSEPH KLUG; THE UNKNOWN HEIRS OF ILONA KLUG; LUCILLE P. CUNNINGHAM; MARYAM H. O. S. ALHOULAH; MUNA H. A. M. H. ALSAYEGH; and all others claiming by, through or under these Defendants, Defendants.

TO: THE UNKNOWN HEIRS OF ILONA KLUG
Last Known Addresses: 7061 S. Tamiami Trl, Apt. 110, Sarasota, FL 34231-5559

YOU ARE NOTIFIED that an action to quiet title on the following property in Lee County, Florida:

Lot 18, Block 37, Unit 10, Section 14, Township 44 South, Range 27 East, Lehigh Acres, according to the map or plat thereof on file in the Office of the Clerk of the Circuit Court, recorded in Plat Book 15, Page 16, Public Records of Lee County, Florida.
Address: 1511 Wellington Avenue, Leigh Acres, FL 33972
Parcel ID: 14-44-27-L2-10037.0180
(the "Property").

has been filed against you and you are required to serve a copy of your writ-

FIRST INSERTION

NOTICE OF ACTION BY PUBLICATION
IN THE COUNTY COURT OF THE TWENTIETH JUDICIAL CIRCUIT IN AND FOR LEE COUNTY, FLORIDA
DIVISION: CIVIL
CASE NO. 24-CC-004901

THE SOUTH SEAS CLUB CONDOMINIUM ASSOCIATION, INC., a Florida non-profit corporation, Plaintiff, vs. BRUCE W. DOUGLAS AND CAROL D. DOUGLAS, Defendants.

TO: BRUCE W. DOUGLAS AND CAROL D. DOUGLAS
Last Known Address: 48 THE FAIRWAYS, MARKHAM, ON L6C3B3, CANADA
YOU ARE HEREBY notified that an action to foreclose a Claim of Lien upon the following described real property located in Lee County, Florida:

Unit Week No. 48 in Condominium Parcel Number M of THE SOUTH SEAS CLUB, a Condominium according to the declaration of Condominium thereof, recorded in Official Records Book 1480 at Page 970, of

SHIP 46 SOUTH, RANGE 25 EAST, ACCORDING TO THE PLAT THEREOF AS RECORDED IN PLAT BOOK 40, PAGE 5, IN THE PUBLIC RECORDS OF LEE COUNTY, FLORIDA.
A/K/A 9382 PINEAPPLE RD
FORT MYERS FL 33967

has been filed against you and you are required to file written defenses with the clerk of court and to serve a copy within 30 days after the first publication of the Notice of Action, on Albertelli Law, Plaintiff's attorney, whose address is P.O. Box 23028, Tampa, FL 33623; otherwise, a default will be entered against you for the relief demanded in the Complaint or petition.

This notice shall be published once a week for two consecutive weeks in the Business Observer.

If you are a person with a disability who needs any accommodation in order to participate in this proceeding, you are entitled, at no cost to you, to the provision of certain assistance. Please contact Brooke Dean, Operations Division Manager, whose office is located at Lee County Justice Center, 1700 Monroe Street, Fort Myers, Florida 33901, and whose telephone number is (239) 533-1771, at least 7 days before your scheduled court appearance, or immediately upon receiving this notification if the time before the scheduled appearance is less than 7 days; if you are hearing or voice impaired, call 711.

WITNESS my hand and the seal of this court on this 23rd day of September, 2024.

Kevin C. Karnes
Clerk of the Circuit Court
(SEAL) By: K. Harris
Deputy Clerk

Albertelli Law
P.O. Box 23028
Tampa, FL 33623
NL- 24-004729
Sept. 27; Oct. 4, 2024 24-04241L

ten defenses by the Lee County Clerk of Court's scheduled default date of October 30, 2024 on Bradley W. Butcher, Plaintiff's attorney, whose address is 6830 Porto Fino Circle, Ste. 2, Fort Myers, Florida 33912 and file the original with this Court either before service on Plaintiff's attorney, or immediately thereafter; otherwise a default will be entered against you for the relief demanded in the Complaint or petition.

This notice shall be published once a week for four (4) consecutive weeks in the Gulf Coast Business Review.

If you are a person with a disability who needs any accommodation in order to participate in this proceeding, you are entitled, at no cost to you, to the provision of certain assistance. Please contact Brooke Dean, Operations Division Manager, whose office is located at Lee County Justice Center, 1700 Monroe Street, Fort Myers, Florida 33901, and whose telephone number is (239) 533-1771, at least 7 days before your scheduled court appearance, or immediately upon receiving this notification if the time before the scheduled appearance is less than 7 days; if you are hearing or voice impaired, call 711.

Dated this 20th day of September, 2024.

CLERK OF THE CIRCUIT COURT
KEVIN C. KARNES
Lee County Clerk of Court
(SEAL) By: K. Harris
as Deputy Clerk

Butcher & Associates, P.L.
6830 Porto Fino Circle, Ste. 2
Fort Myers, Florida 33912
Sept. 27; Oct. 4, 11, 18, 2024
24-04237L

the Public Records of Lee County, Florida, and all amendment thereto, if any.

A/K/A Unit 1310, Week 48
has been filed against you and you are required to serve a copy of your written defenses, if any, upon Michael J. Belle, Esq., of Michael J. Belle, P.A., Attorney for Plaintiff, whose address is 2364 Fruitville Road, Sarasota, Florida 34237, within 30 days from the first date of publication, and file the original with the Clerk of this Court either before service on Plaintiff's attorney or immediately thereafter; otherwise, a default will be entered against you for the relief demanded in the Plaintiff's Complaint.

WITNESS my hand and seal of this Court on this day of 09/20/2024

KEVIN C. KARNES,
CLERK OF COURTS
(SEAL) By: N. Watson
Deputy Clerk

Michael J. Belle, Esq.,
Michael J. Belle, P.A.,
Attorney for Plaintiff,
2364 Fruitville Road,
Sarasota, Florida 34237
service@michaelbelle.com
48085
Sept. 27; Oct. 4, 2024 24-04214L

--- ACTIONS / SALES ---

FIRST INSERTION

NOTICE OF ACTION IN THE CIRCUIT COURT OF THE TWENTIETH JUDICIAL CIRCUIT, IN AND FOR LEE COUNTY, FLORIDA... ROGER SCOTT HAGER Plaintiff, vs. VICTOR VICARIO and ELITE BUILDERS SOUTH LLC, Defendants...

FIRST INSERTION

NOTICE OF SALE IN THE CIRCUIT COURT OF THE TWENTIETH JUDICIAL CIRCUIT IN AND FOR LEE COUNTY, FLORIDA... Wells Fargo Bank, N.A. successor by merger to Wells Fargo Bank Minnesota, N.A. for Reperforming Loan REMIC Trust Certificates, Series 2003-R2...

FIRST INSERTION

NOTICE OF ACTION IN THE CIRCUIT COURT OF THE TWENTIETH JUDICIAL CIRCUIT IN AND FOR LEE COUNTY, FLORIDA... JMK LLC, a Wyoming limited liability company, Plaintiff, v. THE UNKNOWN HEIRS OF JOSEPH KLUG; THE UNKNOWN HEIRS OF ILONA KLUG; LUCILLE P. CUNNINGHAM; MARYAM H. O. S. ALHOULAH; MUNA H. A. M. H. ALSAYEGH; and all others claiming by, through or under these Defendants...

FIRST INSERTION

NOTICE OF ACTION IN THE COUNTY COURT OF THE 20th JUDICIAL CIRCUIT IN AND FOR LEE COUNTY, FLORIDA... EDISON CONDOMINIUM ASSOCIATION, INC., a Florida non-profit corporation, Plaintiff, v. THE UNKNOWN HEIRS OF THOMAS M. KRETSCHMAR and all others claiming by, through or under THOMAS M. KRETSCHMAR, Defendants...

FIRST INSERTION

NOTICE OF ACTION IN THE CIRCUIT COURT OF THE TWENTIETH JUDICIAL CIRCUIT IN AND FOR LEE COUNTY, FLORIDA... of Court's scheduled default date of October 30, 2024 on Bradley W. Butcher, Plaintiff's attorney, whose address is 6830 Porto Fino Circle, Ste. 2, Fort Myers, Florida 33912...

FIRST INSERTION

NOTICE OF ACTION IN THE CIRCUIT COURT OF THE TWENTIETH JUDICIAL CIRCUIT IN AND FOR LEE COUNTY, FLORIDA... of Court's scheduled default date of October 30, 2024 on Bradley W. Butcher, Plaintiff's attorney, whose address is 6830 Porto Fino Circle, Ste. 2, Fort Myers, Florida 33912...

has been filed against you and you are required to serve a copy of your written defenses by the Lee County Clerk of Court's within 30 days on Bradley W. Butcher, Plaintiff's attorney, whose address is 6830 Porto Fino Circle, Ste. 2, Fort Myers, Florida 33912...

CLERK OF THE CIRCUIT COURT KEVIN C. KARNES Lee County Clerk of Court (SEAL) By: K. Harris as Deputy Clerk

Butcher & Associates, P.L. 6830 Porto Fino Circle, Ste. 2 Fort Myers, Florida 33912 Sept. 27; Oct. 4, 2024 24-04240L

Butcher & Associates, P.L. 6830 Porto Fino Circle, Ste. 2 Fort Myers, Florida 33912 Sept. 27; Oct. 4, 11, 18, 2024 24-04239L

Butcher & Associates, P.L. 6830 Porto Fino Circle, Ste. 2 Fort Myers, Florida 33912 Sept. 27; Oct. 4, 11, 18, 2024 24-04238L

FIRST INSERTION

NOTICE OF ACTION IN THE CIRCUIT COURT FOR THE TWENTIETH JUDICIAL CIRCUIT IN AND FOR LEE COUNTY, FLORIDA... NETWORK CAPITAL FUNDING CORPORATION Plaintiff(s), vs. MAGDALYN VILLADA; THE UNKNOWN SPOUSE OF MAGDALYN VILLADA; THE UNKNOWN TENANT IN POSSESSION, Defendant(s)...

CURRENT ADDRESS: 4312 7TH STREET SOUTHWEST LEHIGH ACRES, FL 33976 TO: THE UNKNOWN TENANT IN POSSESSION LAST KNOWN ADDRESS: 4312 7TH STREET SOUTHWEST, LEHIGH ACRES, FL 33976...

FIRST INSERTION

NOTICE OF ACTION IN THE CIRCUIT COURT OF THE TWENTIETH JUDICIAL CIRCUIT IN AND FOR LEE COUNTY, FLORIDA... U.S. BANK TRUST COMPANY, NATIONAL ASSOCIATION, AS TRUSTEE, AS SUCCESSOR-IN-INTEREST TO U.S. BANK NATIONAL ASSOCIATION, NOT IN ITS INDIVIDUAL CAPACITY BUT SOLELY AS INDENTURE TRUSTEE, FOR THE HOLDERS OF THE CIM TRUST 2021-R5, MORTGAGE-BACKED NOTES, SERIES 2021-R5, Plaintiff, vs. LUIS E. LOPEZ; UNKNOWN SPOUSE OF LUIS E. LOPEZ; BRISEIDA LOPEZ a/k/a BRICEIDA LOPEZ; UNKNOWN SPOUSE OF BRICEIDA LOPEZ a/k/a BRICEIDA LOPEZ; LEE COUNTY, STATE OF FLORIDA; UNKNOWN TENANT #1; UNKNOWN TENANT #2; UNKNOWN TENANT #3; UNKNOWN TENANT #4; ALL OTHER UNKNOWN PARTIES CLAIMING INTERESTS BY, THROUGH, UNDER, AND AGAINST THE HEREIN NAMED DEFENDANT(S) WHO ARE NOT KNOWN TO BE DEAD OR ALIVE, WHETHER SAME UNKNOWN PARTIES MAY CLAIM AN INTEREST AS SPOUSES, HEIRS, DEVISEES, GRANTEES, OR OTHER CLAIMANTS...

Current Address: N/A Previous Address: N/A TO: UNKNOWN SPOUSE OF LUIS E. LOPEZ Last Known Address: N/A Current Address: N/A Previous Address: N/A TO: ALL OTHER UNKNOWN PARTIES CLAIMING INTERESTS BY, THROUGH, UNDER, AND AGAINST THE HEREIN NAMED DEFENDANT(S) WHO ARE NOT KNOWN TO BE DEAD OR ALIVE, WHETHER SAME UNKNOWN PARTIES MAY CLAIM AN INTEREST AS SPOUSES, HEIRS, DEVISEES, GRANTEES, OR OTHER CLAIMANTS...

FIRST INSERTION

NOTICE OF FORECLOSURE SALE IN THE CIRCUIT COURT FOR THE TWENTIETH JUDICIAL CIRCUIT IN AND FOR LEE COUNTY, FLORIDA... NEW AMERICAN FUNDING, LLC FKA BROKERS SOLUTIONS, INC., DBA NEW AMERICAN FUNDING Plaintiff(s), vs. JASON J SWANSON; PETER GULBRANDSEN; SANDRA W. GULBRANDSEN; MANATEE BAY PROPERTY OWNERS ASSOCIATION, INC.; THE UNKNOWN SPOUSE OF PETER GULBRANDSEN; Defendant(s)...

45°26' 57" E FOR 226.74 FEET; THENCE RUN S 89°10' 30" W FOR 160.00 FEET TO A POINT ON THE WEST LINE OF SAID SOUTHWEST QUARTER (SE 1/4); THENCE RUN N 0°34' 00" W ALONG SAID WEST LINE FOR 161.38 FEET TO THE POINT OF BEGINNING. SUBJECT TO AND TOGETHER WITH THE HEREINABOVE MENTIONED ROADWAY EASEMENT 60 FEET IN WIDTH; GIVING ACCESS TO STATE ROAD NO. 767; BEARING HEREINABOVE MENTIONED ARE BASED ON THE EAST LINE OF STATE ROAD NO. 767 HAVING A BEARING OF S 10°40' 00" E AS SHOWN ON RECORDED PLAT OF TROPICAL HOMESITES, RECORDED IN PLAT BOOK 12 ON PAGE 68 OF THE PUBLIC RECORDS OF LEE COUNTY, FLORIDA...

You are required to file a written response with the Court and serve a copy of your written defenses, if any, to it on Padgett Law Group, whose address is 6267 Old Water Oak Road, Suite 203, Tallahassee, FL 32312, at least thirty (30) days from the date of first publication, and file the original with the clerk of this court either before service on Plaintiff's attorney or immediately thereafter; otherwise, a default will be entered against you for the relief demanded in the complaint. DATED this the 18th day of September, 2024. Kevin C. Karnes CLERK OF THE CIRCUIT COURT As Clerk of the Court (SEAL) BY: K. Harris Deputy Clerk

Padgett Law Group 6267 Old Water Oak Road, Suite 203 Tallahassee, FL 32312 attorney@padgettlawgroup.com TDP File No. 24-004751-1 Sept. 27; Oct. 4, 2024 24-04265L

of your written defenses within 30 days after the first publication, if any, on McMichael Taylor Gray, LLC, Plaintiff's Attorney, whose address is 7351 Wiles Rd, Ste. 107, Coral Springs, FL 33067, and file the original with this Court either before service on Plaintiff's Attorney, or immediately thereafter; otherwise, a default will be entered against you for the relief demanded in the Complaint or Petition. This Notice shall be published once a week for two consecutive weeks in the BUSINESS OBSERVER. If you are a person with a disability who needs any accommodation in order to participate in this proceeding, you are entitled, at no cost to you, to the provision of certain assistance. Please contact Brooke Dean, Operations Division Manager, whose office is located at Lee County Justice Center, 1700 Monroe Street, Fort Myers, Florida 33901, and whose telephone number is (239) 533-1771, at least 7 days before your scheduled court appearance, or immediately upon receiving this notification if the time before the scheduled appearance is less than 7 days; if you are hearing or voice impaired, call 711. WITNESS my hand and the seal of the court on 09/19/2024. KEVIN C. KARNES CLERK OF THE CIRCUIT COURT (SEAL) By: N. Watson Attorney for Plaintiff: Annalise Hayes DeLuca, Esq. Audrey J. Dixon, Esq. MCMICHAEL TAYLOR GRAY, LLC Attorney for Plaintiff 3550 Engineering Drive, Suite 260 Peachtree Corners, GA 30092 Phone: 404.474.7149 Email: ServiceFL@mtglaw.com Sept. 27; Oct. 4, 2024 24-04231L

YOU ARE NOTIFIED that an action to foreclose a mortgage has been filed against you, in regard to the following property in LEE County, Florida, legally described as: LOT 14, BLOCK 4, UNIT 1, PINE MANOR SUBDIVISION, ACCORDING TO THE PLAT THEREOF AS RECORDED IN PLAT BOOK 9, PAGE 134, IN THE PUBLIC RECORDS OF LEE COUNTY, FLORIDA. This property is located at the street address of: 5556-5558 FIRST AVENUE, FT. MYERS, FL 33907. YOU ARE REQUIRED to serve a copy

TER (SW ¼); THENCE RUN W 89°10' 30" E ALONG SAID NORTH LINE FOR 2052.30 FEET TO A POINT 30.00 FEET EAST OF THE EAST LINE OF SAID SOUTHWEST QUARTER (SW 1/4); THENCE RUN N 0°34' 00" W ALONG A LINE PARALLEL TO AND 30 FEET EAST OF THE EAST LINE OF SAID SOUTHWEST QUARTER (SW 1/4) FOR A DISTANCE OF 378.35 FEET TO A POINT 30.00 FEET SOUTH OF THE NORTH LINE OF THE SOUTHWEST QUARTER (SE 1/4) OF SAID SECTION 23; THENCE RUN N 88°53' 08" E ALONG A LINE PARALLEL TO AND A 30 FEET SOUTH OF (AS MEASURED ON A PERPENDICULAR) SAID NORTH LINE FOR 620.82 FEET TO THE EASTERLY TERMINUS OF SAID CENTERLINE. BEARINGS HEREINABOVE MENTIONED ARE BASED ON THE EAST LINE OF STATE ROAD NO. 767 HAVING A BEARING OF S 10°40' 00" E AS SHOWN ON RECORDED PLAT OF TROPICAL HOMESITES RECORDED IN PLAT BOOK 12 ON PAGE 68 OF THE PUBLIC RECORDS OF LEE COUNTY, FLORIDA. Property address: 3461 Manatee Drive, St. James City, FL 33956 Any person claiming an interest in the surplus from the sale, if any, other than the property owner as of the date of the lis pendens, must file a claim before the clerk reports the surplus as unclaimed. 09/24/2024 Kevin Karnes CLERK OF THE CIRCUIT COURT As Clerk of the Court (SEAL) BY: N. Watson Deputy Clerk Padgett Law Group, Attorney for Plaintiff 6267 Old Water Oak Road, Suite 203 Tallahassee, FL 32312 attorney@padgettlawgroup.com TDP File No. 22-005137-2 Sept. 27; Oct. 4, 2024 24-04257L

PUBLISH YOUR LEGAL NOTICE Call 941-906-9386 and select the appropriate County name from the menu option or email legal@businessobserverfl.com Business Observer

SAVE TIME legal@businessobserverfl.com • Deadline Wednesday at noon • Friday Publication

--- PUBLIC SALES ---

FIRST INSERTION

**REQUEST FOR PROPOSALS ("RFP")
DISASTER DEBRIS REMOVAL AND DISPOSAL SERVICES
FOR
BABCOCK RANCH COMMUNITY INDEPENDENT SPECIAL DISTRICT
AND
NOTICE OF PUBLIC MEETING TO OPEN RFP RESPONSES
AND
NOTICE OF EVALUATION COMMITTEE MEETING
Charlotte and Lee Counties, Florida**

Request for Proposals

Notice is hereby given that Babcock Ranch Community Independent Special District (the "ISD") requests proposals ("RFP") from all qualified firms interested in providing disaster debris removal and disposal services ("Project").

The proposal manual ("Project Manual") will be made available upon request to the District Manager at kantarzhia@whhassociates.com beginning on **September 30, 2024, at 10:00 a.m. (EST)**. The Project Manual will consist of a completed PDF document of the Proposal Package with Specifications containing all available supplemental information. The Project Manual may be amended and supplemented from time to time via a written addendum(s); interested proposers are responsible for ensuring they obtain all available Project Manual, including an addendum, if any.

Any and all questions relative to this request for proposals shall be only directed in writing to Andrew Kantarzhia at kantarzhia@whhassociates.com, and Alyssa Willson at alyssa.willson@kutakrock.com. All questions must be submitted on or before **5:00 p.m. (EST) on October 18, 2024**.

Firms desiring to submit proposals must submit one (1) original, five (5) hard copies and one (1) USB drive which shall contain an electronic copy of their proposal no later than **November 8, 2024, at 1:30 p.m. (EST)** ("Submission Deadline") at 42850 Crescent Loop, Babcock Ranch, FL 33982, attention: Sheena Tamburino

Proposals shall be submitted in a sealed package, shall bear the name of the proposer on the outside of the package and shall clearly identify the proposal as "[Insert Firm's Name] - Babcock Ranch Community Independent Special District - Disaster Debris Removal and Disposal Services Proposal (2024)". Proposals may be either mailed, delivered through expedited service providers, or hand-delivered. No facsimile, telephonic, electronic, or telegraphic submittals will be accepted. Proposals submitted after the Submission Deadline and therefore are not reviewed and considered by the District may be recovered by the firm within ten (10) calendar days of the Submission Deadline. Proposals received after the Submission Deadline that are not reviewed or recovered, may be destroyed by the District.

Ranking of proposals will be made on the basis of qualifications and price according to the criteria set forth in the evaluation criteria contained within the Project Manual; however, please note that in order to be qualified, each proposer must (1) be authorized to do business in Florida, and hold all applicable required state and federal licenses, including but not limited to Charlotte County, in good standing and; (2) have at least five (5) years' experience with services contemplated for the Project.

The District reserves the right in its sole discretion to make amendments, supplements, or changes to the Project Manual up until the time of the proposal submittal, and to provide notice of such changes only to those proposers who have requested a Project Manual. Furthermore, the District reserves the right in its sole discretion to reject any and all proposals or any proposal not conforming to the intent and

purpose of the Project Manual, or waive minor or technical errors, informalities, or irregularities in any proposal, and to award the contract in whole or in part, with or without cause, if it determines in its discretion it is in the best interest of the District to do so and/or pursuant to its Rules of Procedure, as amended.

Any person who wishes to protest the Project Manual, or any component thereof including but not limited to protests relating to this notice, the proposal instructions, proposal forms, contract forms, scope of work, specifications, evaluation criteria and process, or any other issues relating to the Project Manual, shall file with the District a written notice of protest within seventy-two (72) hours (excluding Saturdays, Sundays, and state holidays) after the Project Manual is made available, together with a protest bond in a form acceptable to the District and in the amount of \$10,000, and shall file a formal written protest with the District within seven (7) calendar days (including Saturdays, Sundays, and state holidays) after the date of timely filing the initial notice of protest, stating with particularity the facts and law upon which the protest is based. All such filings must be in accordance with the District's Rules of Procedure, as amended. Filing will be perfected and deemed to have occurred upon receipt by the District Manager. Failure to timely file a notice of protest or failure to timely file a formal written protest shall constitute a waiver of any right to object to or protest the contents of the District's Project Manual and related documents.

Notice of Public Meeting for Proposal Opening

A public meeting will be held on **November 8, 2024, at 1:45 p.m. (EST)** at 42881 Lake Babcock Drive, 2nd floor, Babcock Ranch, FL 33982 (Hatchery East Conference Room). No official action of the District's Board will be taken at this meeting, it is held for the limited purpose of opening the proposals. The meeting is open to the public and will be conducted in accordance with the provisions of Florida law. A copy of the agenda for this meeting may be obtained from the District Manager, Craig Wrathell, at Wrathell, Hunt & Associates, LLC, 2300 Glades Road, Suite 410W, Boca Raton, Florida 33431. This meeting may be continued to a date, time, and place to be specified on the record at the meeting.

Any person requiring special accommodations at this meeting because of a disability or physical impairment should contact the District Office at (877) 276-0889 at least five (5) calendar days prior to the meeting. If you are hearing or speech impaired, please contact the Florida Relay Service at 1-800-955-8770 or 1-800-955-8771, for aid in contacting the District Office.

Notice of Public Meeting for Evaluation Committee

A public meeting of the District's evaluation committee will be held on **November 21, 2024 at 3:00 p.m.** at 42881 Lake Babcock Drive, Second Floor, Babcock Ranch, Florida 33982 (Hatchery East Conference Room). No official action of the District's Board will be taken at this meeting, it is held for the limited purpose of evaluating the proposals. The meeting is open to the public and will be conducted in accordance with the provisions of Florida law. A copy of the agenda for this meeting may be obtained from the District Manager, Craig Wrathell, at Wrathell, Hunt & Associates, LLC, 2300 Glades Road, Suite 410W, Boca Raton, Florida 33431. This meeting may be continued to a date, time, and place to be specified on the record at the meeting.

Any person requiring special accommodations at this meeting because of a disability or physical impairment should contact the District Office at (561) 571-0010 at least five calendar days prior to the meeting. If you are hearing or speech impaired, please contact the Florida Relay Service at 1-800-955-8770 or 1-800-955-8771, for aid in contacting the District Office.
September 27, 2024 24-04270L

FIRST INSERTION

Notice of Public Sale

Notice is hereby given that on October 24, 2024 at 10:00 AM the following vehicles may be sold at public sale for cash for the amount owed on each vehicle to satisfy the lien for repairs, services, storage charges, and any administrative fees allowed pursuant to Florida Statute 713.585. As is. Where is. Title is not guaranteed. CASE: 42839 2014 INTL VIN: 3HSDJSJR5EN057226 Lienor information & Sale Location: RECHTIEN INTERNATIONAL TRUCKS, INC. MV104546 2761 EDISON AVE, FORT MYERS, FL 33916-5302 Ph: 239-334-1000 Total Lien \$ 17029.41 The customer/owner or any other person claiming an interest, or a lien may redeem the vehicle by satisfying the amount due in cash on or before the sale date and time. The customer/owner or any other person claiming an interest, or a lien has a right to file for a hearing prior to the date of sale with the clerk of the courts in the Lee County where the vehicle is held to determine whether the vehicle has been wrongfully taken or withheld from him or her. At any time before the date of sale Owner/Lienholder may recover the vehicle without instituting judicial proceedings by posting a bond as per 559.917 F.S. Net proceeds in excess of lien amount will be deposited with the clerk of courts pursuant to 713.585 F.S.
September 27, 2024 24-04271L

SUBSEQUENT INSERTIONS

--- PUBLIC SALES ---

SECOND INSERTION

NOTICE OF ADMINISTRATIVE COMPLAINT

To: RICHARD NERVAL
Case: CD202403685/D 3233299
An Administrative Complaint to revoke your license and eligibility for licensure has been filed against you. You have the right to request a hearing pursuant to Sections 120.569 and 120.57, Florida Statutes, by mailing a request for same to the Florida Department of Agriculture and Consumer Services, Division of Licensing, Post Office Box 5708 Tallahassee, Florida 32314-5708. If a request for hearing is not received by 21 days from the date of the last publication, the right to hearing in this matter will be waived and the Department will dispose of this cause in accordance with law.
Sept. 20, 27; Oct. 4, 11, 2024
24-03903L

--- ACTIONS ---

THIRD INSERTION

**NOTICE OF ACTION
IN THE CIRCUIT COURT OF THE
TWENTIETH JUDICIAL CIRCUIT,
IN AND FOR LEE COUNTY,
FLORIDA**

Case No.: 22-DR-175

**In Re: The Matter of
MEL-CEPHAS M.D. BOYD,
Petitioner And
JENNA MARIE NERI
Respondent**

To: Respondent, JENNA MARIE NERI
Address: 1138 SW 1st Terrace
Cape Coral, FL 33991
and
423 E. 3rd St., Apt. 200
Little Rock, AR 72201
YOU ARE HEREBY NOTIFIED that an action involving the:
PETITION TO DETERMINE PATERNITY AND FOR RELATED RELIEF

has been filed against you and you are required to serve a copy of the written defenses, in any, to it on counsel for the Petitioner, Natasha Lormil, Esq. with the North Law Firm, who address is 5220 Summerlin Commons Boulevard, Suite 300 Fort Myers, Florida 33907, on or before October 21, 2024 and file the original with the Clerk of this Court either before service on the Petitioner's attorney or immediately thereafter, otherwise a Default will be entered against you for the relief demanded in the Petition.

WITNESS my hand and seal of this Court on September 9, 2024.
CLERK OF THE CIRCUIT COURT
(SEAL) By: E. Bakelman
Deputy Clerk

Natasha Lormil, Esq.
North Law Firm,
5220 Summerlin Commons Boulevard,
Suite 300 Fort Myers, Florida 33907
Sept. 13, 20, 27; Oct. 4, 2024
24-03842L

SECOND INSERTION

**NOTICE OF ACTION FOR
DISSOLUTION OF MARRIAGE
(NO CHILD OR FINANCIAL
SUPPORT)**

IN THE CIRCUIT COURT OF THE
TWENTIETH JUDICIAL CIRCUIT,
IN AND FOR LEE COUNTY,
FLORIDA

Case No.: 24-DR-005815

**Franklin Caceres Molina,
Petitioner, and
Deicy S Romero Castiblanco,
Respondent,**

TO: Deicy S Romero Castiblanco
Address unknown, Unknown
YOU ARE NOTIFIED that an action for dissolution of marriage has been filed against you and that you are required to serve a copy of your written defenses, if any, to it on Franklin Caceres Molina, whose address is 28130 Dovewood Ct Apt 207, Bonita Springs, FL 34135 on or before October 21, 2024, and file the original with the clerk of this Court at 2075 Dr. Martin Luther King, Jr. Blvd. Fort Myers, FL 33901 before service on Petitioner or immediately thereafter. If you fail to do so, a default may be entered against you for the relief demanded in the petition.

Copies of all court documents in this case, including orders, are available at the Clerk of the Circuit Court's office. You may review these documents upon request.

You must keep the Clerk of the Circuit Court's office notified of your current address. (You may file Designation of Current Mailing and E-Mail Address, Florida Supreme Court Approved Family Law Form 12.915.) Future papers in this lawsuit will be mailed or e-mailed to the address(es) on record at the clerk's office.

WARNING: Rule 12.285, Florida Family Law Rules of Procedure, requires certain automatic disclosure of documents and information. Failure to comply can result in sanctions, including dismissal or striking of pleadings.
Dated: 09/11/2024

Kevin C. Karnes
CLERK OF THE CIRCUIT COURT
(SEAL) By: J. Collins
Deputy Clerk
Sept. 20, 27; Oct. 4, 11, 2024
24-03921L

SAVE TIME

Email your Legal Notice
legal@businessobserverfl.com
Deadline Wednesday at noon
Friday Publication

Business Observer

PUBLISH YOUR LEGAL NOTICE

We publish all Public sale, Estate & Court-related notices

- We offer an online payment portal for easy credit card payment
- Service includes us e-filing your affidavit to the Clerk's office on your behalf

Call **941-906-9386** and select the appropriate County name from the menu option or email legal@businessobserverfl.com

FLORIDA'S NEWSPAPER FOR THE C-SUITE

Business Observer

--- PUBLIC SALES ---

SECOND INSERTION

NOTICE OF PUBLIC SALE

The following personal property of Carol Henke and Staci Henken Epranian located at 15897 Sandy Point Dr., lot #284 North Ft. Myers, Florida 34769 will, on October 8, 2024, at 9:00 a.m., be sold for cash to satisfy storage fees in accordance with Florida Statutes, Section 715.109: at the Bayshore Village office, 15711 Shoreline Blvd., Florida 33917.

YEAR/MODEL 1989/BR00
VIN# FLFLK32A10419B7
Title# 475969954 and
YEAR/MODEL 1989/BR00
VIN# FLFLK32B10419B7
Title# 475969961

Additional personal property **unknown**

PREPARED BY:

MARK C. PAYNE, Esq.
Agent for Bayshore Village
P.O. Box 1061
Tampa, Florida 33601-1061
Telephone: 813-223-6882
September 20, 27, 2024

24-03902L

SECOND INSERTION

NOTICE OF UNCLAIMED PROBATE FUNDS DEPOSITED IN COURT REGISTRY

IN THE CIRCUIT COURT OF THE TWENTIETH JUDICIAL CIRCUIT IN AND FOR LEE COUNTY, FLORIDA, PROBATE ACTION **23-CP-002520**

IN RE: The Estate of Patricia C. Blasi
Notice is given that, pursuant to section 733.816, Florida Statutes, unclaimed probate funds of \$86,925.06 are being held for Kelli Jo Blasi in the registry of the court, deposited per order dated 07/24/2024, IN RE: The Estate of Patricia C. Blasi, deceased.

Six months after the posting or the

first publication of this notice, the Clerk of Court will deposit these funds with the Department of Financial Services after deducting fees and costs of publication. Any person or entity entitled to such funds may obtain them by compliance with applicable provisions of F.S. 733.816, Fla. Stat., within 10 years from the date of deposit with the Department of Financial Services, after which time funds will escheat to the State.

Dated: August 22, 2024

KEVIN C. KARNES,
CLERK OF CIRCUIT COURT,
By: s/ Heather Beachy
Deputy Clerk
Aug. 30; Sept. 27, 2024 24-03599L

SECOND INSERTION

NOTICE OF ACTION
IN THE CIRCUIT COURT OF THE TWENTIETH JUDICIAL CIRCUIT IN AND FOR LEE COUNTY, FLORIDA CIVIL ACTION

CASE NO.: 36-2024-CA-005363
FINANCE OF AMERICA REVERSE LLC,

Plaintiff, vs. THE UNKNOWN HEIRS, DEVISEES, GRANTEEES, ASSIGNEES, LIENORS, CREDITORS, TRUSTEES, OR OTHER CLAIMANTS CLAIMING BY, THROUGH, UNDER, OR AGAINST, RICHARD PRIGGE, DECEASED, et al, Defendant(s).

To: THE UNKNOWN HEIRS, DEVISEES, GRANTEEES, ASSIGNEES, LIENORS, CREDITORS, TRUSTEES, OR OTHER CLAIMANTS CLAIMING BY, THROUGH, UNDER, OR AGAINST, RICHARD PRIGGE, DECEASED

Last Known Address: Unknown

Current Address: Unknown

YOU ARE NOTIFIED that an action to foreclose a mortgage on the following property in Lee County, Florida:

THE LAND DESCRIBED HEREIN IS SITUATED IN THE STATE OF FLORIDA, COUNTY OF LEE, DESCRIBED AS FOLLOWS:

LOT 11, BLOCK 11, UNIT 3, LEHIGH ESTATES, SECTION 32, TOWNSHIP 44 SOUTH, RANCH 26 EAST, LEHIGH ACRES, ACCORDING TO THE MAP OR PLAT THEREOF ON FILE IN THE OFFICE OF THE CLERK OF THE CIRCUIT COURT, RECORDED IN PLAT BOOK 15, PAGE 83, PUBLIC RECORDS OF LEE COUNTY, FLORIDA.

A/K/A 2441 HERB AVENUE S LEHIGH ACRES FL 33973

has been filed against you and you are required to file written defenses with the clerk of court and to serve a copy within 30 days after the first publication of the Notice of Action, on Albertelli Law, Plaintiff's attorney, whose address is P.O. Box 23028, Tampa, FL 33623; otherwise, a default will be entered against you for the relief demanded in the Complaint or petition.

This notice shall be published once a week for two consecutive weeks in the Business Observer. If you are a person with a disability who needs any accommodation in order to participate in this proceeding, you are entitled, at no cost to you, to the provision of certain assistance. Please contact Brooke Dean, Operations Division Manager, whose office is located at Lee County Justice Center, 1700 Monroe Street, Fort Myers, Florida 33901, and whose telephone number is (239) 533-1771, at least 7 days before your scheduled court appearance, or immediately upon receiving this notification if the time before the scheduled appearance is less than 7 days; if you are hearing or voice impaired, call 711.

WITNESS my hand and the seal of this court on this 17th day of September, 2024.

Kevin C. Karnes
Clerk of the Circuit Court
(SEAL) By: K. Harris
Deputy Clerk

Albertelli Law
P.O. Box 23028
Tampa, FL 33623
AR-24-012367
September 20, 27, 2024 24-03917L

SECOND INSERTION

NOTICE OF SALE
PURSUANT TO CHAPTER 45
IN THE CIRCUIT COURT OF THE TWENTIETH JUDICIAL CIRCUIT IN AND FOR LEE COUNTY, FLORIDA CIVIL DIVISION

CASE NO. 23-CA-010094
UMB BANK, NATIONAL ASSOCIATION, NOT IN ITS INDIVIDUAL CAPACITY, BUT SOLELY AS LEGAL TITLE TRUSTEE FOR PRL TITLE TRUST I

Plaintiff, vs. JOSHUA D. ELZINGA, et al, Defendants/

NOTICE IS HEREBY GIVEN pursuant to a Final Judgment of Foreclosure dated August 23, 2024, and entered in Case No. 23-CA-010094 of the Circuit Court of the TWENTIETH Judicial Circuit in and for Lee County, Florida, wherein UMB Bank, National Association, not in its individual capacity, but solely as legal title trustee for PRL Title Trust I is the Plaintiff and JOSHUA D. ELZINGA and BRYANNA L. ELZINGA the Defendants. Linda Doggett, Clerk of the Circuit Court in and for Lee County, Florida will sell to the highest and best bidder for cash at www.lee.realforeclose.com, the Clerk's website for on-line auctions at 9:00 AM on 31 day of October 2024, the following described property as set forth in said Order or Final Judgment, to wit:

LOTS 33 AND 34, BLOCK 2168, CAPE CORAL SUBDIVISION, UNIT 32, ACCORDING TO THE MAP OR PLAT THEREOF, AS RECORDED IN PLAT

BOOK 16, PAGES 1 THROUGH 13, OF THE PUBLIC RECORDS OF LEE COUNTY, FLORIDA.

IF YOU ARE A PERSON CLAIMING AN INTEREST IN THE SURPLUS FROM THE SALE, IF ANY, OTHER THAN THE PROPERTY OWNER AS OF THE DATE OF THE LIS PENDENS, YOU MUST FILE A CLAIM WITH THE CLERK OF COURT BEFORE OR NO LATER THAN THE DATE THAT THE CLERK REPORTS THE SURPLUS AS UNCLAIMED. IF YOU FAIL TO FILE A TIMELY CLAIM, YOU WILL NOT BE ENTITLED TO ANY REMAINING FUNDS. AFTER THE FUNDS ARE REPORTED AS UNCLAIMED, ONLY THE OWNER OF THE RECORD AS OF THE DATE OF THE LIS PENDENS MAY CLAIM THE SURPLUS.

If the sale is set aside, the Purchaser may be entitled to only a return of the sale deposit less any applicable fees and costs and shall have no further recourse against the Mortgagor, Mortgagee or the Mortgagee's Attorney.

DATED at Lee County, Florida, this day of 09/13/2024

Kevin C. Karnes, Clerk
Lee County, Florida
(SEAL) By: N. Watson
Deputy Clerk
GILBERT GARCIA GROUP, P.A.
Attorney for Plaintiff(s)
2313 W. Violet St.
Tampa, FL 33603
630282.103314/
September 20, 27, 2024 24-03891L

--- ESTATE ---

SECOND INSERTION

NOTICE TO CREDITORS
IN THE CIRCUIT COURT OF THE TWENTIETH JUDICIAL CIRCUIT IN AND FOR LEE COUNTY, FLORIDA

PROBATE DIVISION
CASE NO. 24-CP-002506
DIVISION: P(2)
IN RE: ESTATE OF MARTIN A. SOUTHARD, Deceased.

The administration of the ESTATE OF MARTIN A. SOUTHARD, deceased, whose date of death was March 17, 2024, is pending in the Circuit Court for Lee County, Florida, Probate Division, the address of which is 1700 Monroe St, Fort Myers, FL 33901. The names and addresses of the personal representative and the personal representative's attorney are set forth below.

All creditors of the decedent and other persons having claims or demands against decedent's estate, on whom a copy of this notice is required to be served, must file their claims with this Court ON OR BEFORE THE LATER OF 3 MONTHS AFTER THE TIME OF THE FIRST PUBLICATION OF THIS NOTICE OR 30 DAYS AFTER THE DATE OF SERVICE OF A COPY OF THIS NOTICE ON THEM.

All other creditors of the decedent and other persons having claims or demands against decedent's estate must file their claims with this Court WITHIN 3 MONTHS AFTER THE DATE OF THE FIRST PUBLICATION OF THIS NOTICE.

ALL CLAIMS NOT FILED WITHIN THE TIME PERIODS SET FORTH IN FLORIDA STATUTES SECTION 733.702 WILL BE FOREVER BARRED.

NOTWITHSTANDING THE TIME PERIOD SET FORTH ABOVE, ANY CLAIM FILED TWO (2) YEARS OR MORE AFTER THE DECEDENT'S DATE OF DEATH IS BARRED.

A personal representative or curator has no duty to discover whether any property held at the time of the decedent's death by the decedent or the decedent's surviving spouse is property to which the Florida Uniform Disposition of Community Property Rights at Death Act as described in sections 732.216-732.228, applies, or may apply, unless a written demand is made by a creditor as specified under section 732.2211.

The date of first publication of this notice is: September 20, 2024.

Signed on this 17th day of September, 2024.

/s/ Daniela K. Pretus
Daniela K. Pretus
Personal Representative
BUCHANAN INGERSOLL & ROONEY PC

Attorneys for Personal Representative
One Biscayne Tower
Two S Biscayne Blvd, Suite 1500
Miami, Florida 33131
Phone: (305) 347-4080
Fax: (305) 347-4089
Primary E-mails:
daniela.pretus@bipc.com;
eservice@bipc.com
Secondary E-mails:
jennifer.rodriguez@bipc.com;
kimberly.ecker@bipc.com
By: /s/ Daniela K. Pretus
Daniela K. Pretus, Esq.
Florida Bar No. 107048
Jennifer M. Rodriguez, Esq.
Florida Bar No. 864781
September 20, 27, 2024 24-03914L

--- ACTIONS ---

FOURTH INSERTION

NOTICE OF ACTION
IN THE CIRCUIT COURT FOR THE TWENTIETH JUDICIAL CIRCUIT IN AND FOR LEE COUNTY, FLORIDA

CASE NO.: 2024-CA-004345
MARTHA CECILIA OROZCO, Plaintiff, v. ROYAL WEST PROPERTIES, INC., a Florida Corporation, AND ALL UNKNOWN PARTIES CLAIMING AN INTEREST BY, THROUGH, UNDER OR AGAINST ANY DEFENDANT, OR CLAIMING ANY RIGHT, TITLE, OR INTEREST IN THE SUBJECT PROPERTY, WHETHER ALIVE OR DEAD, AND THEIR UNKNOWN SPOUSE, HEIRS, DEVISEES, GRANTEEES, CREDITORS, ASSIGNS, OR BENEFICIARIES, Defendants.

To: ROYAL WEST PROPERTIES, INC., a Florida Corporation, AND ALL UNKNOWN PARTIES CLAIMING AN INTEREST BY, THROUGH, UNDER OR AGAINST ANY DEFENDANT, OR CLAIMING ANY RIGHT, TITLE, OR INTEREST IN THE SUBJECT PROPERTY, WHETHER ALIVE OR DEAD, AND THEIR UNKNOWN SPOUSE, HEIRS, DEVISEES, GRANTEEES, CREDITORS, ASSIGNS, OR BENEFICIARIES

YOU ARE NOTIFIED that an action for quiet title on the following properties in Lee County, Florida:

LOTS 17 AND 18, BLOCK 2894,

CAPE CORAL UNIT 41, ACCORDING TO PLAT THEREOF AS RECORDED IN PLAT BOOK 17, PAGES 2 THROUGH 14, INCLUSIVE, OF THE PUBLIC RECORDS OF LEE COUNTY, FLORIDA.

a/k/a 1310 Northwest 11th Terrace, Cape Coral, FL 33993 ("Property")

has been filed against you and you are required to serve a copy of your written defenses, if any, to it on LACI CASADO, ESQ., Plaintiff's attorney, whose address is BARRY L. MILLER, P.A. 11 N. SUMMERLIN AVE., STE. 100, ORLANDO, FL 32801, on or before October 9, 2024 pursuant to Section 94.09 Fla. Stat. (2023), and file the original with the clerk of this court either before service on the plaintiff's attorney or immediately thereafter; otherwise a default will be entered against you for the relief demanded in the complaint or petition.

Dated: 08/30/2024

Kevin C. Karnes
CLERK OF THE COURT
(SEAL) By: K. Harris
As Deputy Clerk

LACI CASADO, ESQ.,
Plaintiff's attorney,
BARRY L. MILLER, P.A.
11 N. SUMMERLIN AVE., STE. 100,
ORLANDO, FL 32801
BML File: 6976LJC
September 6, 13, 20, 27, 2024

24-03727L

FOURTH INSERTION

NOTICE OF ACTION
IN THE CIRCUIT COURT OF THE 20th JUDICIAL CIRCUIT, IN AND FOR LEE COUNTY, FLORIDA

CASE NO.: 23-CA-012053
MODESTO PERERA AND IVONNE PERERA, Husband and wife, Plaintiffs, v.

T & T GULF PROPERTIES LLC; BANK OF AMERICA, N.A.; U.S. BANK TRUST NATIONAL ASSOCIATION, NOT IN ITS INDIVIDUAL CAPACITY BUT SOLELY AS OWNER TRUSTEE FOR RCF 2 ACQUISITION TRUST, and SELENE FINANCE LP, Defendants.
To the Defendant: THE UNKNOWN HEIRS, DEVISEES, LEGATEES, BENEFICIARIES AND GRANTEEES, IF ANY, OF EDITH SANCHEZ, CLAIMING AN INTEREST IN THE REAL PROPERTY WHICH IS THE SUBJECT OF THIS ACTION BY, THROUGH OR UNDER HER

YOU ARE HEREBY NOTIFIED that an action to quiet title on the following property in Lee County, Florida has been filed against you, to wit:

Lots 12 and 13, Block 5796, Cape Coral Unit 88, a subdivision according to the map or plat thereof recorded in the Plat Book 24, Page 127 in the office of the Clerk of the Circuit Court, Lee County, Florida, also known as 3932 NE 23rd Place, Cape Coral, Florida (the "Property").

You are required to serve a copy of your written defenses, if any, to it on Mya M. Hatchette, Esquire, Maynard Nexsen, 200 E. New England Ave., Suite 300, Winter Park, Florida 32789, on or before October 15, 2024, and file the original with the Clerk of this Court either before service on Plaintiff's attorneys or immediately thereafter; otherwise a default will be entered against you for the relief demanded in the complaint or petition.

If you are a person with a disability who needs any accommodation in order to participate in this proceeding, you are entitled, at no cost to you, to the provision of certain assistance. Please contact Brooke Dean, Operations Division Manager, whose office is located at Lee County Justice Center, 1700 Monroe Street, Fort Myers, Florida 33901, and whose telephone number is (239) 533-1771, at least 7 days before your scheduled court appearance, or immediately upon receiving this notification if the time before the scheduled appearance is less than 7 days; if you are hearing or voice impaired, call 711.

Dated: 09/03/2024,

Kevin C. Karnes
Clerk of the Circuit Court
(SEAL) By: N. Watson
As Deputy Clerk
Mya M. Hatchette, Esquire,
Maynard Nexsen,
200 E. New England Ave., Suite 300,
Winter Park, Florida 32789
September 6, 13, 20, 27, 2024

24-03732L

--- ACTIONS / SALES ---

SECOND INSERTION

NOTICE OF ACTION
IN THE CIRCUIT COURT OF THE TWENTIETH JUDICIAL CIRCUIT IN AND FOR LEE COUNTY, FLORIDA

CASE NO.: 24CA4534
BEATTY BUILDERS SITE ACQUISITION INC., Plaintiff, v. DEBT EQUITY VENTURES LLC, and TERRELL PUGH, Defendants.

TO: TERRELL PUGH
11935 SW 188th TERRACE
MIAMI, FL 33177

YOU ARE NOTIFIED that an action to quiet title on the following property in Lee County, Florida:

THE FOLLOWING DESCRIBED LAND, SITUATE, LYING, AND BEING IN LEE COUNTY, FLORIDA, TO WIT: Lots 55 and 56, Block 2605, Unit 37, Cape Coral Subdivision, according to the plat thereof recorded in Plat Book 17, Page 15 through 29, inclusive, of the Public Records of Lee County, Florida.

has been filed against you and that you are required to serve a copy of your written defenses, if any, to it on The Law Office of C.W. Wickersham, Jr., P.A., Plaintiff's attorney, at 2720 Park Street, Suite 205, Jacksonville, Florida, 32205, Phone Number: (904) 389-6202, on or before October 22, 2024, and file the original with the Clerk of this Court, at 2075 DR. Martin Luther King Jr., Blvd, Fort Myers, Florida 33901 before service on Plaintiff or immediately thereafter. If you fail to do so, a Default may be entered against you for the relief demanded in the Complaint.

DATED this day of 09/12/2024

Kevin C. Karnes
Clerk of the Circuit Court
(SEAL) By: N. Watson
As Deputy Clerk

The Law Office of C.W. Wickersham, Jr., P.A.,
Plaintiff's attorney,
2720 Park Street, Suite 205,
Jacksonville, Florida, 32205,
Phone Number: (904) 389-6202
Sept. 20, 27; Oct. 4, 11, 2024

24-03881L

SECOND INSERTION

NOTICE OF ACTION FOR JOINT PETITION FOR TERMINATION OF PARENTAL RIGHTS AND ADOPTION BY STEPPARENT

IN THE CIRCUIT COURT OF THE TWENTIETH JUDICIAL CIRCUIT IN AND FOR LEE COUNTY, FLORIDA

CIVIL ACTION
Case No. 24-DR-5453
Judge: John S. Carlin

IN RE: The Matter of the Adoption of: ISABELLA ROSE OBEN, Adoptee.

TO RESPONDENT: Jonathan Robert Malzan
RESPONDENTS LAST KNOWN ADDRESS: 1137 52nd Street, Sarasota, Florida 34234

YOU ARE NOTIFIED that an action for Joint Petition for Termination of Parental Rights and Adoption by Stepparent has been filed against you and that you are required to serve a copy of your written defenses, if any, to Petitioner's Attorney, Sarah M. Oquendo, Esq., of Coleman, Taylor, Klaus, Doupe, Diaz & Torrez, P.A., at 4099 Tamiami Trail North, Suite 201, Naples, Florida, 34103 on or before October 21, 2024, and file the original with the clerk of this Court at Kevin C. Karnes, Clerk of the Circuit Court and Comptroller, Lee County, Florida, 1700 Monroe Street, Ft. Myers, Florida 33901, before service on Petitioner or immediately thereafter. If you fail to do so, a default may be entered against you for the relief demanded in the petition.

Copies of all court documents in this case, including orders, are available at the Clerk of the Circuit Court's office. You may review these documents upon request.

You must keep the Clerk of the Circuit Court's office notified of your current address. (You may file Designation of Current Mailing and E-Mail Address, Florida Supreme Court Approved Family Law Form 12.915.) Future papers in this lawsuit will be mailed or e-mailed to the addresses on record at the clerk's office.

WARNING: Rule 12.285, Florida Family Law Rules of Procedure, requires certain automatic disclosure of documents and information. Failure to comply can result in sanctions, including dismissal or striking of pleadings.

Dated on: 09/11/2024

KEVIN C. KARNES
CLERK OF THE CIRCUIT COURT
(SEAL) By: J. Collins
As Deputy Clerk
Sarah M. Oquendo, Esq.,
Coleman, Taylor, Klaus, Doupe, Diaz & Torrez, P.A.,
4099 Tamiami Trail North, Suite 201,
Naples, Florida, 34103
Sept. 20, 27; Oct. 4, 11, 2024

24-03892L

SECOND INSERTION

NOTICE TO CREDITORS
IN THE CIRCUIT COURT FOR LEE COUNTY, FLORIDA
PROBATE DIVISION
File No.: 24DCP-002839

Division: Probate
IN RE: ESTATE OF NEVIN J. MINDLIN, Deceased.

The administration of the Estate of Nevin J. Mindlin, deceased, whose date of death was November 1, 2023, is pending in the Circuit Court for Lee County, Florida, Probate Division, the address of which is P.O. Box 9346, Fort Myers, FL 33902-9346. The names and addresses of the Personal Representative and the Personal Representative's attorney are set forth below.

All creditors of the Decedent and other persons having claims or demands against the Decedent's Estate on whom a copy of this Notice is required to be served must file their claims with this Court WITHIN THE LATER OF 3 MONTHS AFTER THE TIME OF THE FIRST PUBLICATION OF THIS NOTICE OR 30 DAYS AFTER THE DATE OF SERVICE OF A COPY OF THIS NOTICE ON THEM.

All other creditors of the Decedent and other persons having claims or demands against the Decedent's Estate must file their claims with this Court WITHIN 3 MONTHS AFTER THE DATE OF THE FIRST PUBLICATION OF THIS NOTICE.

ALL CLAIMS NOT FILED WITHIN THE TIME PERIODS SET FORTH IN SECTION 733.702 OF THE FLORIDA PROBATE CODE WILL BE FOREVER BARRED.

NOTWITHSTANDING THE TIME PERIODS SET FORTH ABOVE, ANY CLAIM FILED TWO (2) YEARS OR MORE AFTER THE DECEDENT'S DATE OF DEATH IS BARRED.

The date of first publication of this Notice is September 20, 2024.

Personal Representative:
Joshua J. Mindlin
1016 Stratford Avenue
Elkins Park, PA 19027

Attorney for Personal Representative:
Aglæ S. Van den Bergh
Attorney for Personal Representative
Florida Bar Number: 1031166
GREEN SCHOENFELD & KYLE LLP
1380 Royal Palm Square Boulevard
Fort Myers, Florida 33919
Telephone: (239) 936P7200
Fax: (239) 936P7997
E-Mail:
aglaevandenbergh@gskattorneys.com
00956434.RTF/1
September 20, 27, 2024 24-03893L

SECOND INSERTION

NOTICE TO CREDITORS
IN THE CIRCUIT FOR LEE COUNTY, FLORIDA
PROBATE DIVISION
FILE NUMBER: 2024-2715-CP
IN RE: ESTATE OF NEIL PATRICK MAURIELLO Deceased.

The administration of the estate of Neil Patrick Mauriello, deceased, whose date of death was July 1, 2024, File Number 2024-2715-CP, is pending in the Circuit Court for Lee County, Florida, Probate Division, the address of which is 1700 Monroe Street 1st Floor, Ft. Myers, FL 33901. The names and addresses of the Personal Representative and the Personal Representative's Attorney are set forth below.

All creditors of the decedent and other persons having claims or demands against decedent's estate on whom a copy of this notice has been served must file their claims within this court ON OR BEFORE THE LATER OF 3 MONTHS AFTER THE TIME OF THE FIRST PUBLICATION OF THIS NOTICE OR 30 DAYS AFTER THE DATE OF SERVICE OF A COPY OF THIS NOTICE ON THEM.

All other creditors of the decedent and other persons having claims or demands against decedent's estate must file their claims with this court WITHIN 3 MONTHS AFTER THE DATE OF THE FIRST PUBLICATION OF THIS NOTICE.

ALL CLAIMS NOT SO FILED WITHIN THE TIME PERIODS SET FORTH IN FLORIDA STATUTES SECTION 733.702 WILL BE FOREVER BARRED.

NOTWITHSTANDING THE TIME PERIOD SET FORTH ABOVE, ANY CLAIM FILED TWO (2) YEARS OR MORE AFTER THE DECEDENT'S DATE OF DEATH IS BARRED.

The date of first publication of this notice is September 20, 2024.

Personal Representative
Signature: Kirk Mauriello
Email: kirkmauriello@gmail.com
Kirk Mauriello

11311 Canal Grande Drive
Fort Myers, Florida 33913
Attorney for Personal Representative:
/s/ Anthony J. Dimora
Anthony J. Dimora, Esquire
Florida Bar Number: 0092347
Woodward, Pires & Lombardo, P.A.
606 Bald Eagle Drive, Suite 500
Post Office Box One
Marco Island, Florida 34146
Telephone Number: (239) 394-5161
adimora@wpl-legal.com
September 20, 27, 2024 24-03897L

--- ESTATE ---

SECOND INSERTION

NOTICE TO CREDITORS
IN THE CIRCUIT COURT FOR LEE COUNTY, FLORIDA
PROBATE DIVISION
File No. 24-CP-002815
IN RE: ESTATE OF
REBECCA LYNN TOUS
Deceased.

The administration of the estate of Rebecca Lynn Tous, deceased, whose date of death was July 16, 2024, is pending in the Circuit Court for Lee County, Florida, Probate Division, the address of which is 1700 Monroe Street, Fort Myers, Florida 33901. The names and addresses of the personal representative and the personal representative's attorney are set forth below.

All creditors of the decedent and other persons having claims or demands against decedent's estate on whom a copy of this notice is required to be served must file their claims with this court ON OR BEFORE THE LATER OF 3 MONTHS AFTER THE TIME OF THE FIRST PUBLICATION OF THIS NOTICE OR 30 DAYS AFTER THE DATE OF SERVICE OF A COPY OF THIS NOTICE ON THEM.

The personal representative has no duty to discover whether any property held at the time of the decedent's death by the decedent or the decedent's surviving spouse is property to which the Florida Uniform Disposition of Community Property Rights at Death Act as described in ss. 732.216-732.228, Florida Statutes, applies, or may apply,

unless a written demand is made by a creditor as specified under s. 732.2211, Florida Statutes.

All other creditors of the decedent and other persons having claims or demands against decedent's estate must file their claims with this court WITHIN 3 MONTHS AFTER THE DATE OF THE FIRST PUBLICATION OF THIS NOTICE.

ALL CLAIMS NOT FILED WITHIN THE TIME PERIODS SET FORTH IN FLORIDA STATUTES SECTION 733.702 WILL BE FOREVER BARRED.

NOTWITHSTANDING THE TIME PERIODS SET FORTH ABOVE, ANY CLAIM FILED TWO (2) YEARS OR MORE AFTER THE DECEDENT'S DATE OF DEATH IS BARRED.

The date of first publication of this notice is September 20, 2024.

Personal Representative:
/s/ Susan Tous Ritchie
Susan Tous Ritchie
14781 Calusa Palms Drive APT 101
Fort Myers, Florida 33919

Attorney for Personal Representative:
/s/ Monica Johnson
Monica Johnson, Esq., Attorney
Florida Bar Number: 1028229
Sunshine State Law, PLLC
2058 Cottage Street
Fort Myers, Florida 33901
Telephone: (239) 790-4477
Fax: (239) 201-2662
E-Mail:
info@sunshinestatelawoffice.com
September 20, 27, 2024 24-03907L

SECOND INSERTION

NOTICE TO CREDITORS
THE CIRCUIT COURT FOR LEE COUNTY, FLORIDA
PROBATE DIVISION
File No. 24-CP-002567
IN RE: ESTATE OF
MICHAEL WILLIAM YUDKIN
AKA MICHAEL YUDKIN,
Deceased.

The administration of the Estate of Michael William Yudkin aka Michael Yudkin, deceased, whose date of death was May 4, 2024, is pending in the Circuit Court for Lee County, Florida, Probate Division, the address of which is 2075 Dr. Martin Luther King, Jr. Boulevard, Justice Center, 2nd Floor, Fort Myers, Florida 33901. The names and addresses of the Personal Representative and the Personal Representative's attorney are set forth below.

All creditors of the decedent and other persons having claims or demands against decedent's estate on whom a copy of this notice is required to be served must file their claims with this court ON OR BEFORE THE LATER OF 3 MONTHS AFTER THE TIME OF THE FIRST PUBLICATION OF THIS NOTICE OR 30 DAYS AFTER THE DATE OF SERVICE OF A COPY OF THIS NOTICE ON THEM.

All other creditors of the decedent and other persons having claims or demands against decedent's estate must file their claims with this court WITHIN 3 MONTHS AFTER THE DATE OF THE FIRST PUBLICATION OF THIS NOTICE.

ALL CLAIMS NOT FILED WITHIN THE TIME PERIODS SET FORTH IN FLORIDA STATUTES SECTION 733.702 WILL BE FOREVER BARRED.

NOTWITHSTANDING THE TIME PERIODS SET FORTH ABOVE, ANY CLAIM FILED TWO (2) YEARS OR MORE AFTER THE DECEDENT'S DATE OF DEATH IS BARRED.

A Personal Representative or curator has no duty to discover whether any property held at the time of the decedent's death by the decedent or the decedent's surviving spouse is property to which the Florida Uniform Disposition of Community Property Rights at Death Act as described in sections 732.216-732.228, applies, or may apply, unless a written demand is made by a creditor as specified under section 732.2211.

The date of first publication of this notice is September 20, 2024.

Edith Lea Yudkin
Personal Representative

Gary A. Phillips, Esq.
Attorney for Personal Representative
Florida Bar Number: 66168
COLE SCHOTZ, P.C.
2255 Glades Road, Suite 300E
One Boca Place
Boca Raton, Florida 33431
Telephone: (561) 221-6700
Fax: (561) 423-0494
Primary Email:
gphillips@coleschotz.com
Secondary Email:
mharvey@coleschotz.com
September 20, 27, 2024 24-03909L

SECOND INSERTION

NOTICE TO CREDITORS
IN THE CIRCUIT COURT FOR LEE COUNTY, FLORIDA
PROBATE DIVISION
File No. 24-CP-002868
Division Probate
IN RE: ESTATE OF
PHILIP MICHAEL HILLMER
Deceased.

The administration of the estate of Philip Michael Hillmer, deceased, whose date of death was August 5, 2024, is pending in the Circuit Court for Lee County, Florida, Probate Division, the address of which is 1700 Monroe St, Ft. Myers, FL 33901. The names and addresses of the personal representative and the personal representative's attorney are set forth below.

All creditors of the decedent and other persons having claims or demands against decedent's estate on whom a copy of this notice is required to be served must file their claims with this court ON OR BEFORE THE LATER OF 3 MONTHS AFTER THE TIME OF THE FIRST PUBLICATION OF THIS NOTICE OR 30 DAYS AFTER THE DATE OF SERVICE OF A COPY OF THIS NOTICE ON THEM.

The personal representative has no duty to discover whether any property held at the time of the decedent's death by the decedent or the decedent's surviving spouse is property to which the Florida Uniform Disposition of Community Property Rights at Death Act as described in ss. 732.216-732.228, Florida Statutes, applies, or may apply, unless a written demand is made by a creditor as specified under s. 732.2211, Florida Statutes.

All other creditors of the decedent and other persons having claims or demands against decedent's estate must file their claims with this court WITHIN 3 MONTHS AFTER THE DATE OF THE FIRST PUBLICATION OF THIS NOTICE.

ALL CLAIMS NOT FILED WITHIN THE TIME PERIODS SET FORTH IN FLORIDA STATUTES SECTION 733.702 WILL BE FOREVER BARRED.

NOTWITHSTANDING THE TIME PERIODS SET FORTH ABOVE, ANY CLAIM FILED TWO (2) YEARS OR MORE AFTER THE DECEDENT'S DATE OF DEATH IS BARRED.

The date of first publication of this notice is September 20, 2024.

Personal Representative:
Sandra Crebessa-Wrisk

134 Charles Avenue
Wewahatchka, Florida 32465
Attorney for Personal Representative:
Eviانا J. Martin, Attorney
Florida Bar Number: 36198
Martin Law Firm, PL
3701 Del Prado Blvd S.
Cape Coral, Florida 33904
Telephone: (239) 443-1094
Fax: (941) 213-1231
E-Mail:
eviana.martin@martinlawfirm.com
September 20, 27, 2024 24-03925L

SECOND INSERTION

NOTICE TO CREDITORS
IN THE CIRCUIT COURT FOR LEE COUNTY, FLORIDA
PROBATE DIVISION
File No. 24CP002719
IN RE: ESTATE OF
BARBARA ANN CAMPBELL

The administration of the estate of BARBARA ANN CAMPBELL, deceased, whose date of death was July 22, 2023; File Number 24CP002719, is pending in the Circuit Court for Lee County, Florida, Probate Division, the address of which is Post Office Box 2469, Fort Myers, FL 33902. The names and addresses of the personal representative and the personal representative's attorney are set forth below.

All creditors of the decedent and other persons having claims or demands against decedent's estate, on whom a copy of this notice is required to be served must file their claims with this court WITHIN THE LATER OF 3 MONTHS AFTER THE TIME OF THE FIRST PUBLICATION OF THIS NOTICE OR 30 DAYS AFTER THE DATE OF SERVICE OF A COPY OF THIS NOTICE ON THEM.

All other creditors of the decedent and other persons having claims or demands against decedent's estate must file their claims with this court WITHIN 3 MONTHS AFTER THE DATE OF THE FIRST PUBLICATION OF THIS NOTICE.

ALL CLAIMS NOT FILED WITHIN THE TIME PERIODS SET FORTH IN SECTION 733.702 OF THE FLORIDA PROBATE CODE WILL BE FOREVER BARRED.

NOTWITHSTANDING THE TIME PERIOD SET FORTH ABOVE, ANY CLAIM FILED TWO (2) YEARS OR MORE AFTER THE DECEDENT'S DATE OF DEATH IS BARRED.

The date of first publication of this notice is: September 20, 2024.

LEONA MARGARET CAMPBELL
Personal Representative

521 NW 18th Avenue
Cape Coral, Florida 33993
Derek B. Alvarez, Esquire -
FBN: 114278
DBA@GendersAlvarez.com
Anthony F. Diecidue, Esquire -
FBN: 146528
AFD@GendersAlvarez.com
Whitney C. Miranda, Esquire -
FBN 65928
WCM@GendersAlvarez.com
GENDEERS ALVAREZ DIECIDUE, P.A.
2307 West Cleveland Street
Tampa, Florida 33609
Phone: (813) 254-4744
Fax: (813) 254-5222
Eservice for all attorneys listed above:
GADeservice@GendersAlvarez.com
September 20, 27, 2024 24-03908L

SECOND INSERTION

NOTICE TO CREDITORS
IN THE CIRCUIT COURT FOR LEE COUNTY, FLORIDA
PROBATE DIVISION
File No. 24-CP-000928
Division Probate
IN RE: ESTATE OF
DONNA MAE HENAUULT,
Deceased.

The administration of the estate of Donna Mae Henault, deceased, whose date of death was February 4, 2024, is pending in the Circuit Court for Lee County, Florida, Probate Division, the address of which is Lee County Clerk of Circuit Court, 1700 Monroe St., Fort Myers, FL, 33901. The names and addresses of the personal representative and the personal representative's attorney are set forth below.

All creditors of the decedent and other persons having claims or demands against decedent's estate on whom a copy of this notice is required to be served must file their claims with this court ON OR BEFORE THE LATER OF 3 MONTHS AFTER THE TIME OF THE FIRST PUBLICATION OF THIS NOTICE OR 30 DAYS AFTER THE DATE OF SERVICE OF A COPY OF THIS NOTICE ON THEM.

All other creditors of the decedent and other persons having claims or demands against decedent's estate must file their claims with this court WITHIN 3 MONTHS AFTER THE DATE OF THE FIRST PUBLICATION OF THIS NOTICE.

The personal representative has no duty to discover whether any property held at the time of the decedent's death by the decedent or the decedent's surviving spouse is property to which the Florida Uniform Disposition of Community Property Rights at Death Act as described in ss. 732.216-732.228, applies, or may apply, unless a written demand is made by a creditor as specified under s. 732.2211, Florida Statutes.

ALL CLAIMS NOT FILED WITHIN THE TIME PERIODS SET FORTH IN FLORIDA STATUTES SECTION 733.702 WILL BE FOREVER BARRED.

NOTWITHSTANDING THE TIME PERIOD SET FORTH ABOVE, ANY CLAIM FILED TWO (2) YEARS OR MORE AFTER THE DECEDENT'S DATE OF DEATH IS BARRED.

The date of first publication of this notice is September 20, 2024.

Personal Representative:
/s/ Christina M. Andrews
Christina M. Andrews
9 Windy Ridge Place
Waterford, CT 06385

Attorney for Personal Representative:
/s/ Jeffrey A. Attia
Jeffrey A. Attia
E-Mail Address:
jeff@jeffreyyattialaw.com
Florida Bar No. 0108199
The Law Office of Jeffrey Attia, PA
6719 Winkler Road, Suite 114
Fort Myers, FL 33919
Telephone: 239-919-2318
September 20, 27, 2024 24-03884L

SECOND INSERTION

NOTICE TO CREDITORS
IN THE CIRCUIT COURT FOR LEE COUNTY, FLORIDA
PROBATE DIVISION
File No. 24-CP-002841
Division: Probate
IN RE: ESTATE OF
HENRY G. HAGER,
Deceased.

The administration of the estate of Henry G. Hager, deceased, whose date of death was June 27, 2024, is pending in the Circuit Court for Lee County, Florida, Probate Division, the address of which is P.O. Box 9346, Fort Myers, FL 33902. The names and addresses of the personal representatives and the personal representatives' attorney are set forth below.

All creditors of the decedent and other persons having claims or demands against decedent's estate on whom a copy of this notice is required to be served must file their claims with this court ON OR BEFORE THE LATER OF 3 MONTHS AFTER THE TIME OF THE FIRST PUBLICATION OF THIS NOTICE OR 30 DAYS AFTER THE DATE OF SERVICE OF A COPY OF THIS NOTICE ON THEM.

The personal representative has no duty to discover whether any property held at the time of the decedent's death by the decedent or the decedent's surviving spouse is property to which the Florida Uniform Disposition of Community Property Rights at Death Act as described in ss. 732.216-732.228, Florida Statutes, applies, or may apply,

unless a written demand is made by a creditor as specified under s. 732.2211, Florida Statutes.

All other creditors of the decedent and other persons having claims or demands against decedent's estate must file their claims with this court WITHIN 3 MONTHS AFTER THE DATE OF THE FIRST PUBLICATION OF THIS NOTICE.

ALL CLAIMS NOT FILED WITHIN THE TIME PERIODS SET FORTH IN FLORIDA STATUTES SECTION 733.702 WILL BE FOREVER BARRED.

NOTWITHSTANDING THE TIME PERIODS SET FORTH ABOVE, ANY CLAIM FILED TWO (2) YEARS OR MORE AFTER THE DECEDENT'S DATE OF DEATH IS BARRED.

The date of first publication of this notice is September 20, 2024.

Personal Representatives:
Eleanor H. Temelini

8 Cornauba Street Ext.
Roslindale, MA 02131
Hannah H. Davis
4214 Taylor Rd.
Jamesville, NY 13078
Attorney for Personal Representatives:
Joe C. Cuffel
Florida Bar Number: 1019964
GREEN SCHOENFELD & KYLE LLP
1380 Royal Palm Square Blvd.
Fort Myers, FL 33919
Telephone: (239) 936-7200
Fax: (239) 936-7997
E-Mail: joecuffel@gskattorneys.com
September 20, 27, 2024 24-03883L

--- SALES ---

SECOND INSERTION

NOTICE OF FORECLOSURE SALE
IN THE CIRCUIT COURT OF THE TWENTIETH JUDICIAL CIRCUIT IN AND FOR LEE COUNTY, FLORIDA
GENERAL JURISDICTION
DIVISION
Case No. 23-CA-013526

Freedom Mortgage Corporation
Plaintiff, vs.

Rebeca Estevez; Juan C. Vargas Barrio; Unknown Spouse of Juan C. Vargas Barrio
Defendants.

NOTICE IS HEREBY GIVEN pursuant to the Final Judgment and/or Order Rescheduling Foreclosure Sale entered in Case No. 23-CA-013526 of the Circuit Court of the TWENTIETH Judicial Circuit, in and for Lee County, Florida, wherein Freedom Mortgage Corporation is the Plaintiff and Rebeca Estevez; Juan C. Vargas Barrio; Unknown Spouse of Juan C. Vargas Barrio are the Defendants, that I will sell to the highest and best bidder for cash by electronic sale at www.lee.realforeclose.com, beginning at 09:00 AM. on the 10th day of October, 2024, the following described property as set forth in said Final Judgment, to wit:

LOT 11, BLOCK 79, UNIT 17, GREENBRIAR, SECTION 4, TOWNSHIP 44 SOUTH, RANGE 27 EAST, LEHIGH ACRES, ACCORDING TO PLAT THEREOF, AS RECORDED IN PLAT BOOK 27, PAGE 27, OF THE PUBLIC RECORDS OF LEE COUNTY, FLORIDA.
Dated this day of 09/12/2024.

Kevin Karnes
As Clerk of the Court
(SEAL) By: N. Watson
As Deputy Clerk

BROCK & SCOTT PLLC
2001 NW 64th St, Suite 130
Ft. Lauderdale, FL 33309
Attorney for Plaintiff
File # 23-F02314
September 20, 27, 2024 24-03869L

SECOND INSERTION

NOTICE OF SALE
IN THE COUNTY COURT OF THE TWENTIETH JUDICIAL CIRCUIT IN AND FOR LEE COUNTY, FLORIDA

Case No. 23-CC-007221
CALOOSA LAKES HOMEOWNERS ASSOCIATION, INC.,

Plaintiff, v.
SAMINATU TEJANSI AND JAMILIA YELIA JALLOH,
Defendant,

NOTICE IS HEREBY GIVEN that, pursuant to the Final Judgment of Foreclosure entered in this cause on September 3, 2024, by the County Court of Lee County, Florida, the property described as:

Lot 149, CALOOSA LAKES, PHASE 1, according to the Plat thereof as recorded in Instrument Number 2006000358513, of the Public Records of Lee County, Florida.

and more commonly known as 10501 Canal Brook Lane, Lehigh Acres, FL 33936 (hereinafter "Property").

will be sold to the highest bidder for cash at public sale by the Lee County Clerk of Court, Kevin C. Karnes, electronically online at www.lee.realforeclose.com at 9:00 A.M. on October 4, 2024.

Any person claiming an interest in the surplus from the sale, if any, other than the property owner as of the date of the Lis Pendens must file a claim in accordance with Florida Statutes, Section 45.031.

Dated this 16th day of September 2024.

Kevin C. Karnes
Clerk of Court
(SEAL) N. Watson

/s/ Allison Nelson
Tiffany M. Love Esq.
Florida Bar No.: 92884
Tiffany.Love@arlaw.com
Allison Nelson, Esq.
Florida Bar No. 1049314
Adams and Reese LLP
ADAMS AND REESE LLP
100 N. Tampa Street, Suite 4000
Tampa, FL 33602
Telephone: (813) 227-5541
Facsimile: (813) 227-5641
Attorneys for Plaintiff
September 20, 27, 2024 24-03899L

SECOND INSERTION

NOTICE TO CREDITORS
(Summary Administration)
IN THE CIRCUIT COURT FOR LEE COUNTY, FLORIDA
PROBATE DIVISION
File No. 24-CP-002775
IN RE: ESTATE OF
CHIRDCHAI CHAROENSRI
Deceased.

TO ALL PERSONS HAVING CLAIMS OR DEMANDS AGAINST THE ABOVE ESTATE:

You are hereby notified that an Order of Summary Administration has been entered in the estate of Chirdchai Charoensri, deceased, File Number 24-CP-002775, by the Circuit Court for Lee County, Florida, Probate Division, the address of which is 1700 Monroe St, Fort Myers, FL 33901; that the

decedent's date of death was May 7, 2024; that the total value of the estate is \$60,000 and that the names and addresses of those to whom it has been assigned by such order are:

Name	Address
Vanida Charoensri	12780 Kenwood Ln #206 Ft. Myers, Florida 33907

ALL INTERESTED PERSONS ARE NOTIFIED THAT:

All creditors of the estate of the decedent and persons having claims or demands against the estate of the decedent other than those for whom provision for full payment was made in the Order of Summary Administration must file their claims with this court WITHIN THE TIME PERIODS SET FORTH IN FLORIDA STATUTES

SECTION 733.702. ALL CLAIMS AND DEMANDS NOT SO FILED WILL BE FOREVER BARRED. NOTWITHSTANDING ANY OTHER APPLICABLE TIME PERIOD, ANY CLAIM FILED TWO (2) YEARS OR MORE AFTER THE DECEDENT'S DATE OF DEATH IS BARRED.

The personal representative has no duty to discover whether any property held at the time of the decedent's death by the decedent or the decedent's surviving spouse is property to which the Florida Uniform Disposition of Community Property Rights at Death Act as described in ss. 732.216-732.228, Florida Statutes, applies, or may apply, unless a written demand is made by a creditor as specified under s. 732.2211, Florida

Statutes.

The date of first publication of this Notice is September 20, 2024.

Person Giving Notice:
Karitttha Charoensri

P.O. Box 862
Sanibel, Florida 33957
Attorney for Person Giving Notice
/s/ Heidi M. Brown
Heidi M. Brown, Attorney
Florida Bar Number: 48692
Osterhout & McKinney, P.A.
3783 Seago Lane
Fort Myers, FL 33901
Telephone: (239) 939-4888
Fax: (239) 277-0601
E-Mail: heidib@omplaw.com
Secondary E-Mail:
hillaryh@omplaw.com
September 20, 27, 2024 24-03886L

--- SALES ---

SECOND INSERTION

NOTICE OF SALE PURSUANT TO CHAPTER 45
IN THE COUNTY COURT OF THE TWENTIETH JUDICIAL CIRCUIT IN AND FOR LEE COUNTY, FLORIDA
GENERAL JURISDICTION
DIVISION
CASE NO. 23-CC-4676
CYPRESS CAY PROPERTY ASSOCIATION, INC., A FLORIDA NOT FOR PROFIT CORPORATION,
PLAINTIFF, V.
WILLIAM DEBELLA, ET AL.,
DEFENDANTS.

NOTICE IS HEREBY GIVEN pursuant to a Final Judgment of Fore-

closure dated June 18, 2024, and entered in Case No. 23-CC-4676 of the County Court of the Twentieth Judicial Circuit in and for Lee County, Florida, wherein CYPRESS CAY PROPERTY ASSOCIATION, INC. is Plaintiff, and William Debella, Lesa Debella, Unknown Tenant One n/k/a Jessica Wylie, Secretary of Housing and Urban Development, Citibank, N.A., Florida Water Products, Inc. and Bank of America, N.A. are Defendants, I will sell to the highest and best bidder for cash: [x] www.lee.realforeclose.com, the Clerk's website for online auctions, at 9:00 AM, on the 10th day of October, 2024 the following described property as

set forth in said Final Judgment, to wit:

Lot 28 of Cypress Cay, according to the Plat thereof as recorded in Plat Book 71, Pages 5 through 9, of the Public Records of Lee County, Florida.
A/K/A: 11472 Lake Cypress Loop, Fort Myers, FL 33913
A PERSON CLAIMING AN INTEREST IN THE SURPLUS FROM THE SALE, IF ANY, OTHER THAN THE PROPERTY OWNER AS OF THE DATE OF THE LIS PENDENS MUST FILE A CLAIM WITHIN SIXTY (60) DAYS AFTER THE SALE.
DATED this day of 09/12/2024

KEVIN C. KARNES,
as Clerk of said Court
(SEAL) By: N. Watson
As Deputy Clerk

BECKER & POLIAKOFF, P.A.
Attorneys for Plaintiff
Carolyn C. Meadows, Esq.
Florida Bar #92888
Six Mile Corporate Park
12140 Carissa Commerce Court,
Suite 200
Fort Myers, FL 33966
Phone: (239) 433-7707
Fax: (239) 433-5933
Primary email:
cofoservice@mail@beckerlawyers.com
2525249v1.C06748/414822
September 20, 27, 2024 24-03868L

Q&A What is a public notice?
A public notice is information intended to inform citizens of government activities. The notice should be published in a forum independent of the government, readily available to the public, capable of being securely archived and verified by authenticity.
The West Orange Times carries public notices in Orange County, Florida.

--- ESTATE ---

SECOND INSERTION

NOTICE TO CREDITORS
IN THE CIRCUIT COURT FOR LEE COUNTY, FLORIDA PROBATE DIVISION
File No. 24-CP-002647
IN RE: ESTATE OF EDWARD J. SWEENEY
Deceased.

The administration of the estate of Edward J. Sweeney, deceased, whose date of death was January 21, 2024, is pending in the Circuit Court for Lee County, Florida, Probate Division, the address of which is 1700 Monroe St, Fort Myers, FL 33901. The names and addresses of the personal representative and the personal representative's attorney are set forth below.

All creditors of the decedent and other persons having claims or demands against decedent's estate on whom a copy of this notice is required to be served must file their claims with this court ON OR BEFORE THE LATER OF 3 MONTHS AFTER THE TIME OF THE FIRST PUBLICATION OF THIS NOTICE OR 30 DAYS AFTER THE DATE OF SERVICE OF A COPY OF THIS NOTICE ON THEM.

All other creditors of the decedent and other persons having claims or demands against decedent's estate must file their claims with this court WITHIN 3 MONTHS AFTER THE DATE OF THE FIRST PUBLICATION OF THIS NOTICE.

ALL CLAIMS NOT FILED WITHIN THE TIME PERIODS SET FORTH IN FLORIDA STATUTES SECTION 733.702 WILL BE FOREVER BARRED.

NOTWITHSTANDING THE TIME PERIODS SET FORTH ABOVE, ANY CLAIM FILED TWO (2) YEARS OR MORE AFTER THE DECEDENT'S DATE OF DEATH IS BARRED.

A personal representative or curator has no duty to discover whether any property held at the time of the decedent's death by the decedent or the decedent's surviving spouse is property to which the Florida Uniform Disposition of Community Property Rights at Death Act as described in sections 732.216-732.228, applies, or may apply, unless a written demand is made by a creditor as specified under section 732.2211.

The date of first publication of this notice is 9/20/24.

Personal Representative:**Scott Satiriz**6191 Robinson Street
Jupiter, Florida 33458

Attorney for Personal Representative:

Andrew Ponnock, Attorney
Florida Bar Number: 19542010100 West Sample Road, 3rd Fl
Coral Springs, FL 33065

Telephone: (954) 340-4051

Fax: (954) 340-3411

E-Mail: andy@ponnocklaw.com

September 20, 27, 2024 24-03885L

SECOND INSERTION

NOTICE TO CREDITORS
IN THE CIRCUIT COURT FOR LEE COUNTY, FLORIDA PROBATE DIVISION
File No. 24-CP-002481
IN RE: ESTATE OF VIRGINIA M. LANEY
Deceased.

The administration of the estate of Virginia M. Laney, deceased, whose date of death was November 17, 2023, is pending in the Circuit Court for Lee County, Florida, Probate Division, the address of which is 2075 Dr Martin Luther King Jr Blvd, Fort Myers, FL 33901. The names and addresses of the personal representative and the personal representative's attorney are set forth below.

All creditors of the decedent and other persons having claims or demands against decedent's estate on whom a copy of this notice is required to be served must file their claims with this court ON OR BEFORE THE LATER OF 3 MONTHS AFTER THE TIME OF THE FIRST PUBLICATION OF THIS NOTICE OR 30 DAYS AFTER THE DATE OF SERVICE OF A COPY OF THIS NOTICE ON THEM.

All other creditors of the decedent and other persons having claims or demands against decedent's estate must file their claims with this court WITHIN 3 MONTHS AFTER THE DATE OF THE FIRST PUBLICATION OF THIS NOTICE.

ALL CLAIMS NOT FILED WITHIN THE TIME PERIODS SET FORTH IN FLORIDA STATUTES SECTION 733.702 WILL BE FOREVER BARRED.

NOTWITHSTANDING THE TIME PERIODS SET FORTH ABOVE, ANY CLAIM FILED TWO (2) YEARS OR MORE AFTER THE DECEDENT'S DATE OF DEATH IS BARRED.

A personal representative or curator has no duty to discover whether any property held at the time of the decedent's death by the decedent or the decedent's surviving spouse is property to which the Florida Uniform Disposition of Community Property Rights at Death Act as described in sections 732.216-732.228, applies, or may apply, unless a written demand is made by a creditor as specified under section 732.2211.

The date of first publication of this notice is September 20, 2024.

Personal Representative:**Leah Treppel**14641 Seminole Trail
Seminole, Florida 33776

Attorney for Personal Representative:

Katie Everlove-Stone, Attorney
Florida Bar Number: 302715328 Central Ave
St. Petersburg, FL 33707

Telephone: (727) 471-0675

Fax: (866) 326-7610

E-Mail: katie@everlovelegal.com

September 20, 27, 2024 24-03912L

SECOND INSERTION

NOTICE TO CREDITORS
IN THE CIRCUIT COURT OF THE TWENTIETH JUDICIAL CIRCUIT IN AND FOR LEE COUNTY, FLORIDA PROBATE DIVISION
CASE NO.: 24-CP-2776
IN RE: THE ESTATE OF CHERIE LYNN DAVIS
Deceased.

The administration of the estate of CHERIE LYNN DAVIS, deceased, whose date of death was July 15, 2024, is pending in the Circuit Court for Lee County, Florida, Probate Division, the address of which is P.O. Box 9346, Fort Myers, FL 33902. The names and addresses of the Personal Representative and the Personal Representative's attorney are set forth below.

All creditors of the decedent and other persons having claims or demands against decedent's estate on whom a copy of this notice is required to be served must file their claims with this court ON OR BEFORE THE LATER OF 3 MONTHS AFTER THE TIME OF THE FIRST PUBLICATION OF THIS NOTICE OR 30 DAYS AFTER THE DATE OF SERVICE OF A COPY OF THIS NOTICE ON THEM.

All other creditors of the decedent and other persons having claims or demands against decedent's estate must file their claims with this court WITHIN 3 MONTHS AFTER THE DATE OF THE FIRST PUBLICATION OF THIS NOTICE.

ALL CLAIMS NOT FILED WITHIN THE TIME PERIODS SET FORTH IN FLORIDA STATUTES SECTION 733.702 WILL BE FOREVER BARRED.

NOTWITHSTANDING THE TIME PERIODS SET FORTH ABOVE, ANY CLAIM FILED TWO (2) YEARS OR MORE AFTER THE DECEDENT'S DATE OF DEATH IS BARRED.

The date of first publication of this notice is September 20, 2024.

Personal Representative:**JOSHUA GREEN**22 Abbott Place
Berlin, MD 21811

Attorney for Personal Representative:

EDWARD E. WOLLMAN
Florida Bar No. 0618640

Email: ewollman@wga-law.com

Alternate Email:

pleadings@wga-law.com

PATRICK COURVILLE

Florida Bar No. 0115708

Email: pcourville@wga-law.com

Alternate Email:

pleadings@wga-law.com

Attorneys for Personal Representative

WOLLMAN GEHRKE &

ASSOCIATES, P.A.

2235 Venetian Court, Suite 5

Naples, Florida 34109

Telephone: (239) 435-1533

Fax: (239) 435-1433

September 20, 27, 2024 24-03896L

SECOND INSERTION

NOTICE TO CREDITORS
IN THE CIRCUIT COURT OF THE TWENTIETH JUDICIAL CIRCUIT IN AND FOR LEE COUNTY, FLORIDA PROBATE DIVISION
CASE NO.: 24-CP-2711
IN RE: THE ESTATE OF JEFFREY JOHN GILSON
Deceased.

The administration of the estate of JEFFREY JOHN GILSON, deceased, whose date of death was April 30, 2024, is pending in the Circuit Court for Lee County, Florida, Probate Division, the address of which is 1700 Monroe Street, Fort Myers, Florida 33901. The names and addresses of the personal representative and the personal representative's attorneys are set forth below.

All creditors of the decedent and other persons having claims or demands against decedent's estate on whom a copy of this notice is required to be served must file their claims with this court ON OR BEFORE THE LATER OF 3 MONTHS AFTER THE TIME OF THE FIRST PUBLICATION OF THIS NOTICE OR 30 DAYS AFTER THE DATE OF SERVICE OF A COPY OF THIS NOTICE ON THEM.

All other creditors of the decedent and other persons having claims or demands against decedent's estate must file their claims with this court WITHIN 3 MONTHS AFTER THE DATE OF THE FIRST PUBLICATION OF THIS NOTICE.

ALL CLAIMS NOT FILED WITHIN THE TIME PERIODS SET FORTH IN FLORIDA STATUTES SECTION 733.702 WILL BE FOREVER BARRED.

NOTWITHSTANDING THE TIME PERIODS SET FORTH ABOVE, ANY CLAIM FILED TWO (2) YEARS OR MORE AFTER THE DECEDENT'S DATE OF DEATH IS BARRED.

The date of first publication of this notice is September 20, 2024.

Personal Representative:**KELLY CONWAY**210 Sleepy Hollow Lane
Steamboat Springs, CO 80487

Attorney for Personal Representative:

EDWARD V. SMITH
Florida Bar Number: 102848

E-Mail: esmith@wga-law.com

Secondary E-Mail:

pleadings@wga-law.com

PATRICK COURVILLE

Florida Bar Number: 0115708

E-Mail: pcourville@wga-law.com

Secondary E-Mail:

pleadings@wga-law.com

Attorneys for Personal Representative

WOLLMAN GEHRKE &

ASSOCIATES, P.A.

2235 Venetian Court, Suite 5

Naples, Florida 34109

Telephone: (239) 435-1533

Fax: (239) 435-1433

September 20, 27, 2024 24-03900L

SECOND INSERTION

NOTICE TO CREDITORS
IN THE CIRCUIT COURT FOR LEE COUNTY, FLORIDA PROBATE DIVISION
File No. 24-CP-002095
IN RE: ESTATE OF JUDY M. EATON
Deceased.

The administration of the Estate of Judy M. Eaton, deceased, whose date of death was March 15, 2024, is pending in the Circuit Court for Lee County, Florida, Probate Division, the address of which is P. O. Box 9346, Fort Myers, FL 33902. The names and addresses of the Personal Representative and the Personal Representative's attorney are set forth below.

All creditors of the decedent and other persons having claims or demands against decedent's estate on whom a copy of this notice is required to be served must file their claims with this Court ON OR BEFORE THE LATER OF 3 MONTHS AFTER THE TIME OF THE FIRST PUBLICATION OF THIS NOTICE OR 30 DAYS AFTER THE DATE OF SERVICE OF A COPY OF THIS NOTICE ON THEM.

All other creditors of the decedent and other persons having claims or demands against decedent's estate must file their claims with this Court WITHIN 3 MONTHS AFTER THE DATE OF THE FIRST PUBLICATION OF THIS NOTICE.

ALL CLAIMS NOT FILED WITHIN THE TIME PERIODS SET FORTH IN FLORIDA STATUTES SECTION 733.702 WILL BE FOREVER BARRED.

NOTWITHSTANDING THE TIME PERIODS SET FORTH ABOVE, ANY CLAIM FILED TWO (2) YEARS OR MORE AFTER THE DECEDENT'S DATE OF DEATH IS BARRED.

A Personal Representative or curator has no duty to discover whether any property held at the time of the decedent's death by the decedent or the decedent's surviving spouse is property to which the Florida Uniform Disposition of Community Property Rights at Death Act as described in sections 732.216-732.228, applies, or may apply, unless a written demand is made by a creditor as specified under section 732.2211.

The date of first publication of this notice is September 20, 2024.

Personal Representative:**Beau R. Morris**2637 E 600 North Rd
Stewardson, Illinois 62463

Attorney for Personal Representative:

Carol R. Sellers
Florida Bar Number: 893528

3525 Bonita Beach Rd., Ste 103

Bonita Springs, FL 34134

Telephone: (239) 992-2031

Fax: (239) 992-0723

E-Mail:

csellers@richardsonsellers.com

September 20, 27, 2024 24-03901L

SECOND INSERTION

NOTICE TO CREDITORS
IN THE CIRCUIT COURT OF THE TWENTIETH JUDICIAL CIRCUIT IN AND FOR LEE COUNTY, FLORIDA PROBATE DIVISION
File Number 36-2024-CP-002797-A0-01CH
IN RE: Estate of ALVIN J. REICHENBACH
Deceased

The administration of the estate of ALVIN J. REICHENBACH, deceased, whose date of death was April 6, 2024 is pending in the Circuit Court for Lee County, Florida, Probate Division, the address of which is P.O. Box 9346, Ft. Myers, FL 33902. The names and addresses of the personal representative and the personal representative's attorney are set forth below.

All creditors of the decedent and other persons having claims or demands against decedent's estate on whom a copy of this notice is required to be served must file their claims with this court ON OR BEFORE THE LATER OF 3 MONTHS AFTER THE TIME OF THE FIRST PUBLICATION OF THIS NOTICE OR 30 DAYS AFTER THE DATE OF SERVICE OF A COPY OF THIS NOTICE ON THEM.

All other creditors of the decedent and other persons having claims or demands against decedent's estate must file their claims with this court WITHIN 3 MONTHS AFTER THE DATE OF THE FIRST PUBLICATION OF THIS NOTICE.

ALL CLAIMS NOT FILED WITHIN THE TIME PERIODS SET FORTH IN FLORIDA STATUTES SECTION 733.702 WILL BE FOREVER BARRED.

NOTWITHSTANDING THE TIME PERIOD SET FORTH ABOVE, ANY CLAIM FILED TWO (2) YEARS OR MORE AFTER THE DECEDENT'S DATE OF DEATH IS BARRED.

A Personal Representative or curator has no duty to discover whether any property held at the time of the decedent's death by the decedent or the decedent's surviving spouse is property to which the Florida Uniform Disposition of Community Property Rights at Death Act as described in ss. 732.216-732.228, applies, or may apply, unless a written demand is made by a creditor as specified under s. 732.2211.

The date of first publication of this notice is September 20, 2024

Personal Representative:**Cassandra Reichenbach**1619 Shannon Drive
Janesville, WI 53546WIDERMAN MALEK, PL
Attorney for Personal RepresentativeScott C. Dixon, Esquire
Florida Bar Number 0109797

1990 W. New Haven Ave., Suite 201

Melbourne, FL 32904

321-255-2332

Email: sdixon@USLegalTeam.com

September 20, 27, 2024 24-03906L

SECOND INSERTION

NOTICE TO CREDITORS
IN THE CIRCUIT COURT FOR LEE COUNTY, FLORIDA PROBATE DIVISION
File No. 24-CP-002782
Division Probate
IN RE: ESTATE OF BROOKS C. MCARTH, DECEASED.

The administration of the estate of Brooks C. McArthur, deceased, whose date of death was April 27, 2024, is pending in the Circuit Court for Lee County, Florida, Probate Division, the address of which is Justice Center, 2075 Dr. Martin Luther King Jr. Blvd., 2nd Floor, Fort Myers, Florida 33901. The names and addresses of the personal representatives and the personal representatives' attorney are set forth below.

All creditors of the decedent and other persons having claims or demands against decedent's estate on whom a copy of this notice is required to be served must file their claims with this court ON OR BEFORE THE LATER OF 3 MONTHS AFTER THE TIME OF THE FIRST PUBLICATION OF THIS NOTICE OR 30 DAYS AFTER THE DATE OF SERVICE OF A COPY OF THIS NOTICE ON THEM.

The personal representative has no duty to discover whether any property held at the time of the decedent's death by the decedent or the decedent's surviving spouse is property to which the Florida Uniform Disposition of Community Property Rights at Death Act as described in ss. 732.216-732.228, Florida Statutes, applies, or may apply, unless a written demand is made by a

creditor as specified under s. 732.2211, Florida Statutes.

All other creditors of the decedent and other persons having claims or demands against decedent's estate must file their claims with this court WITHIN 3 MONTHS AFTER THE DATE OF THE FIRST PUBLICATION OF THIS NOTICE.

ALL CLAIMS NOT FILED WITHIN THE TIME PERIODS SET FORTH IN FLORIDA STATUTES SECTION 733.702 WILL BE FOREVER BARRED.

NOTWITHSTANDING THE TIME PERIODS SET FORTH ABOVE, ANY CLAIM FILED TWO (2) YEARS OR MORE AFTER THE DECEDENT'S DATE OF DEATH IS BARRED.

The date of first publication of this notice is September 20, 2024.

Personal Representatives:**Christy L. McArthur****c/o Dunwoody White & Landon, P.A.**
4001 Tamiami Trail North, Suite 200

Naples, FL 34103

Michelle M. Forthaus**c/o Dunwoody White & Landon, P.A.**
4001 Tamiami Trail North, Suite 200

Naples, FL 34103

Attorneys for Personal Representatives:

DUNWODY WHITE & LANDON, P.A.

Alfred J. Stashis, Jr., Esq.

Florida Bar Number: 14772

Gregory F. Sztot

Florida Bar Number: 42547

4001 Tamiami Trail North, Suite 200

Naples, FL 34103

Telephone: (239) 263-5885

Fax: (239) 262-1442

September 20, 27, 2024 24-03905L

SECOND INSERTION

NOTICE TO CREDITORS
IN THE CIRCUIT COURT FOR LEE COUNTY, FLORIDA PROBATE DIVISION
File No. 24-CP-002670
Division Probate
IN RE: ESTATE OF WILLIAM DUANE SCARBRO a/k/a WILLIAM D. SCARBRO
Deceased.

The administration of the estate of William Duane Scarbro a/k/a William D. Scarbro, deceased, whose date of death was September 3, 2023, is pending in the Circuit Court for Lee County, Florida, Probate Division, the address of which is P.O. Box 9346, Fort Myers, Florida 33902. The names and addresses of the personal representative and the personal representative's attorney are set forth below.

All creditors of the decedent and other persons having claims or demands against decedent's estate on whom a copy of this notice is required to be served must file their claims with this court ON OR BEFORE THE LATER OF 3 MONTHS AFTER THE TIME OF THE FIRST PUBLICATION OF THIS NOTICE OR 30 DAYS AFTER THE DATE OF SERVICE OF A COPY OF THIS NOTICE ON THEM.

All other creditors of the decedent and other persons having claims or demands against decedent's estate must file their claims with this court WITHIN 3 MONTHS AFTER THE DATE OF THE FIRST PUBLICATION OF THIS NOTICE.

ALL CLAIMS NOT FILED WITHIN

THE TIME PERIODS SET FORTH IN FLORIDA STATUTES SECTION 733.702 WILL BE FOREVER BARRED.

NOTWITHSTANDING THE TIME PERIODS SET FORTH ABOVE, ANY CLAIM FILED TWO (2) YEARS OR MORE AFTER THE DECEDENT'S DATE OF DEATH IS BARRED.

A personal representative or curator has no duty to discover whether any property held at the time of the decedent's death by the decedent or the decedent's surviving spouse is property to which the Florida Uniform Disposition of Community Property Rights at Death Act as described in sections 732.216-732.228, applies, or may apply, unless a written demand is made by a creditor as specified under section 732.2211.

The date of first publication of this notice is September 20, 2024.

Personal Representative:**/S/ JANET K. COBB****Janet K. Cobb**

905 Eastover Drive

Bloomfield Twp, Michigan 48304

Attorney for Personal Representative:

/S/ A. STEPHEN KOTLER

A. Stephen Kotler

Florida Bar Number: 629103

Kotler Law Firm P.L.

999 Vanderbilt Beach Road, Suite 200

Naples, Florida 34108

Telephone: (239) 325-2333

Fax: (239) 325-1853

E-Mail: skotler@kotlerpl.com

Secondary E-Mail:

paralegal@kotlerpl.com

September 20, 27, 2024 24-03913L

SECOND INSERTION

NOTICE TO CREDITORS
IN THE CIRCUIT COURT FOR LEE COUNTY, FLORIDA PROBATE DIVISION
File No. 24-CP-002539
IN RE: ESTATE OF LESSLY WAYNE BLACKWELL,
Deceased.

The administration of the estate of Lessly Wayne Blackwell, deceased, whose date of death was May 22, 2024, is pending in the Circuit Court for Lee County, Florida, Probate Division, the mailing address of which is P.O. Box 9346, Fort Myers, FL 33902 and the physical location is Justice Center, 2nd Floor, 2075 Dr. Martin Luther King Jr. Boulevard, Fort Myers, FL 33901. The names and addresses of the personal representative and the personal representative's attorney are set forth below.

All creditors of the decedent and other persons having claims or demands against decedent's estate on whom a copy of this notice is required to be served must file their claims with this court ON OR BEFORE THE LATER OF 3 MONTHS AFTER THE TIME OF THE FIRST PUBLICATION OF THIS NOTICE OR 30 DAYS AFTER THE DATE OF SERVICE OF A COPY OF THIS NOTICE ON THEM.

All other creditors of the decedent and other persons having claims or demands against decedent's estate must file their claims with this court WITHIN 3 MONTHS AFTER THE DATE OF THE FIRST PUBLICATION OF THIS NOTICE.

ALL CLAIMS NOT FILED WITHIN

THE TIME PERIODS SET FORTH IN FLORIDA STATUTES SECTION 733.702 WILL BE FOREVER BARRED.

NOTWITHSTANDING THE TIME PERIOD SET FORTH ABOVE, ANY CLAIM FILED TWO (2) YEARS OR MORE AFTER THE DECEDENT'S DATE OF DEATH IS BARRED.

The personal representative or curator has no duty to discover whether any property held at the time of the decedent's death by the decedent's surviving spouse is property to which the Florida Uniform Disposition of Community Property Rights at Death Act, as described in sections 732.216 through 732.228, Florida Statutes, applies, or may

SECOND INSERTION

NOTICE OF ACTION
IN THE CIRCUIT COURT OF THE
20TH JUDICIAL CIRCUIT, IN AND
FOR LEE COUNTY, FLORIDA
CIVIL DIVISION
CASE NO. 24-CA-004721
LOANDEPOT.COM, LLC,
Plaintiff, vs.
ALL UNKNOWN HEIRS,
CREDITORS, DEVISEES,
BENEFICIARIES, GRANTEEES,
ASSIGNEES, LIENORS,
TRUSTEES AND ALL OTHER
PARTIES CLAIMING AN
INTEREST BY, THROUGH,
UNDER OR AGAINST THE
ESTATE OF ANDREA BOIGUES
A/K/A ANDREA ANTONIA
BOIGUES, DECEASED; ANDREA
A. RODRIGUEZ; VICKY
CABALLERO; MIGUEL E.
MARTINEZ; FOXMOOR LAKES
MASTER ASSOCIATION,
INC.; FOXMOOR LAKES
HOMEOWNER'S ASSOCIATION,
INC.; UNKNOWN PERSON(S) IN
POSSESSION OF THE SUBJECT
PROPERTY,
Defendant(s)
To the following Defendant(s):
ALL UNKNOWN HEIRS, CREDI-
TORS, DEVISEES, BENEFICIARIES,
GRANTEES, ASSIGNEES, LIENORS,
TRUSTEES AND ALL OTHER
PARTIES CLAIMING AN INTER-
EST BY, THROUGH, UNDER OR
AGAINST THE ESTATE OF ANDREA

BOIGUES A/K/A ANDREA ANTO-
NIA BOIGUES, DECEASED
(LAST KNOWN ADDRESS)
5571 FOXLAKE DR
NORTH FORT MYERS, FLORIDA
33917
MIGUEL E. MARTINEZ
(LAST KNOWN ADDRESS)
27 NE 20TH AVE
CAPE CORAL, FLORIDA 33909
YOU ARE NOTIFIED that an action
for Foreclosure of Mortgage on the fol-
lowing described property:
SEE EXHIBIT "A"
EXHIBIT "A"
Description of a Parcel of Land
lying in Section 36, Township
43 South, Range 24 East, Lee
County, Florida (FOXMOOR
LAKES, PHASE II, BUILDING
#19, UNIT A)
A tract of parcel of land situated
in the State of Florida, County of
Lee, being a part of Section 36,
Township 43 South, Range 24
East, and further bounded and
described as follows:
Starting at the Southwest corner
of the Southeast 1/4 of said Sec-
tion 36; thence South 89°21'53"
East along the Southerly line of
said Section 36 for 757.50 feet;
thence North 00°38'07" East
for 1406.85 feet to a point on a
curve concave to the Southwest
have a radius of 350.00 feet and
to which point a radial line bears

North 20°39'18" East, said curve
being the Northeasterly right-
of-way line of New Post Road
(100.00 feet wide, recorded in
Official Records Book 1129, Page
1687, of the Public Records of
Lee County, Florida); thence
North 56°01'45" East along a
non-tangent line to said curve
for 312.05 feet; thence South
43°29'22"; East for 61.47 feet to
the center point of Building #19
and the Point of Beginning of
the herein described Unit A; thence
South 46°30'38" West for 45.50
feet; thence North 43°29'22"
West for 32.83 feet; thence
North 46°30'38" East for 45.50
feet; thence South 43°29'22"
East for 32.83 feet to the Point of
Beginning.
a/k/a 5571 FOXLAKE DR,
NORTH FORT MYERS, FLOR-
IDA 33917
has been filed against you and you
are required to serve a copy of your writ-
ten defenses, if any, to it, on Kahane &
Associates, P.A., Attorney for Plaintiff,
whose address is 1619 NW 136th Ave-
nue, Suite D-220, Sunrise, FLORIDA
33323 within thirty (30) days after the
first publication of this Notice in the
BUSINESS OBSERVER and file the
original with the Clerk of this Court
either before service on Plaintiff's at-
torney or immediately thereafter; oth-
erwise a default will be entered against

you for the relief demanded in the com-
plaint.
If you are a person with a disabili-
ty who needs any accommodation in
order to participate in this proceed-
ing, you are entitled, at no cost to you,
to the provision of certain assistance.
Please contact Brooke Dean, Opera-
tions Division Manager, whose office
is located at Lee County Justice Cen-
ter, 1700 Monroe Street, Fort Myers,
Florida 33901, and whose telephone
number is (239) 533-1771, at least 7
days before your scheduled court ap-
pearance, or immediately upon receiv-
ing this notification if the time before
the scheduled appearance is less than
7 days; if you are hearing or voice im-
paired, call 711.
WITNESS my hand and the seal of
this Court this day of 09/11/2024
KEVIN C. KARNES
As Clerk of the Court
(SEAL) By N. Watson
As Deputy Clerk
Submitted by:
Kahane & Associates, P.A.
1619 NW 136th Avenue,
Suite D-220
Sunrise, Florida 33323
Telephone: (954) 382-3486
Telefacsimile: (954) 382-5380
Designated service email:
notice@kahaneandassociates.com
24-00693 LND
September 20, 27, 2024
24-03873L

SECOND INSERTION

NOTICE OF ACTION
IN THE CIRCUIT COURT OF THE
TWENTIETH JUDICIAL CIRCUIT
IN AND FOR LEE COUNTY,
FLORIDA
CASE NO.: 24-CA-004817
LAKEVIEW LOAN SERVICING,
LLC,
Plaintiff, v.
JENNA SKYE STRICKLAND, et al.,
Defendants.
TO: Christopher J. Berti a/k/a Christo-
pher Berti
16781 Lloyd Road
North Fort Myers FL 33917
Jenna Skye Strickland
16781 Lloyd Road
North Fort Myers FL 33917
Unknown Spouse of Christopher J.
Berti a/k/a Christopher Berti
16781 Lloyd Road
North Fort Myers FL 33917
Unknown Spouse of Jenna Skye Strick-
land
16781 Lloyd Road
North Fort Myers FL 33917
YOU ARE HEREBY NOTIFIED that
an action to foreclose a mortgage on the
following described property in Lee
County, Florida:
The South 80 feet of Lot 12,
Block 5, PARFREY SUBDIVI-
SION, according to the plat
thereof recorded in Plat Book 7,
Page 41, Public Records of Lee
County, Florida.
has been filed against you and you
are required to serve a copy of your written
defenses, if any, on Anthony R. Smith,
Esquire, the Plaintiff's attorney, whose
address is Tiffany & Bosco, P.A., 1201 S.

Orlando Ave, Suite 430, Winter Park,
FL 32789, on or before thirty (30) days
from the date of first publication of this
Notice, and file the original with the
Clerk of this Court either before service
on the Plaintiff's attorney or immedi-
ately thereafter; or a default will be
entered against you for the relief dem-
anded in the complaint.
If you are a person with a disability
who needs any accommodation in order
to participate in this proceeding, you
are entitled, at no cost to you, to the
provision of certain assistance. Please
contact Brooke Dean, Operations Divi-
sion Manager, whose office is located at
Lee County Justice Center, 1700 Mon-
roe Street, Fort Myers, Florida 33901,
and whose telephone number is (239)
533-1771, at least 7 days before your
scheduled court appearance, or immedi-
ately upon receiving this notification
if the time before the scheduled appear-
ance is less than 7 days; if you are hear-
ing or voice impaired, call 711.
IN WITNESS WHEREOF, I have
hereunto set my hand and affixed the
official seal of said Court at Lee County,
Florida, this 12 day of September, 2024.
Kevin C. Karnes
as Clerk of the Circuit Court of
Lee County, Florida
(SEAL) By: K Shoap
DEPUTY CLERK
Anthony R. Smith, Esquire,
the Plaintiff's attorney,
Tiffany & Bosco, P.A.,
1201 S. Orlando Ave, Suite 430,
Winter Park, FL 32789
September 20, 27, 2024
24-03880L

SECOND INSERTION

NOTICE OF ACTION;
CONSTRUCTIVE SERVICE -
PROPERTY
IN THE CIRCUIT COURT OF THE
TWENTIETH JUDICIAL CIRCUIT
OF THE STATE OF FLORIDA, IN
AND FOR LEE COUNTY,
CIVIL DIVISION
CASE NO.: 2023-CA-012866
BIT CAPITAL INVESTMENTS,
CORP.,
Plaintiff, vs.
BLANCHE SHEEHY A/K/A
BLANCHE HALEY; ALICIA
SHEEHY; INDIGO GROUP,
INC.; JOSEPH P. RYAN; ALICE
E. MATTISON; FLORIDA
LANDMARK COMMUNITIES,
INC.; and CLAUDINE TITECA,
Defendants.
TO: Alice E. Mattison, 1301 Brookwood
St, Bensenville, IL 60106
Claudine Titeca, Residence Hampton,
Rue Du Ham 134 Box D3, 1180 Brux-
elles, Belgium
YOU ARE NOTIFIED that an action
to quiet title to the following properties
in Lee County, Florida:
LOT 10, BLOCK 32, UNIT 4,
SECTION 2, TOWNSHIP 45
SOUTH, RANGE 27 EAST,
LEHIGH ACRES, ACCORD-
ING TO THE MAP OR PLAT
THEREOF ON FILE IN THE
OFFICE OF THE CLERK OF
THE CIRCUIT COURT, RE-
CORDED IN PLAT BOOK 15,
PAGE 192, PUBLIC RECORDS,
LEE COUNTY, FLORIDA.
And;
LOT 3, BLOCK 111, UNIT 22,
SOUTHWOOD, SECTION
8, TOWNSHIP 45 SOUTH,
RANGE 27 EAST, LEHIGH
ACRES, FLORIDA, ACCORD-
ING TO THE MAP OR PLAT

THEREOF ON FILE IN THE
OFFICE OF THE CLERK OF
THE CIRCUIT COURT, RE-
CORDED IN PLAT BOOK 26,
PAGE 85, PUBLIC RECORDS,
LEE COUNTY, FLORIDA.
And;
LOT 16, BLOCK 111, UNIT 22,
SOUTHWOOD, SECTION
8, TOWNSHIP 45 SOUTH,
RANGE 27 EAST, LEHIGH
ACRES, FLORIDA, ACCORD-
ING TO THE MAP OR PLAT
THEREOF ON FILE IN THE
OFFICE OF THE CLERK OF
THE CIRCUIT COURT, RE-
CORDED IN PLAT BOOK 26,
PAGE 85, PUBLIC RECORDS,
LEE COUNTY, FLORIDA
has been filed against you and you
are required to serve a copy of your written
defenses, if any, to it on Sokolof Remtul-
la, LLP, the plaintiff's attorney, whose
address is 6801 Lake Worth Road, Suite
100E, Greenacres, FL 33467, on or be-
fore October 21, 2024, and file the origi-
nal with the clerk of this court either be-
fore service on the plaintiff's attorney or
immediately thereafter; otherwise a
default will be entered against you for
the relief demanded in the complaint or
petition.
DATED on 09/11/2024
KEVIN KARNES
CLERK OF THE CIRCUIT COURT
(SEAL) By: N. Watson
DEPUTY CLERK
SOKOLOF REMTULLA, LLP
6801 Lake Worth Road, Suite 100E
Greenacres, FL 33467
Telephone: 561-507-5252
Facsimile: 561-342-4842
E-mail: pleadings@sokrem.com
Counsel for Plaintiff
Sept. 20, 27, Oct. 4, 11, 2024
24-03879L

NOTICE OF ACTION
IN THE CIRCUIT COURT OF THE
TWENTIETH JUDICIAL CIRCUIT
IN AND FOR LEE COUNTY,
FLORIDA
CASE NO.: 24-CA-004710
GIOVANNA CRISTINA VALENIA
ARIAS and DIEGO ALBERTO
VASQUEZ MARIN,
Plaintiff(s), v.
UNKNOWN HEIR OF DOUGLAS
M. DOBRINICH #1, UNKNOWN
HEIR OF DOUGLAS M.
DOBRINICH #2, UNKNOWN HEIR
OF DOUGLAS M. DOBRINICH #3,
UNKNOWN HEIR OF DOUGLAS
M. DOBRINICH #4 and LEHIGH
ACRES PROPERTIES, LLC,
Defendant.
TO: UNKNOWN HEIR OF DOUG-
LAS M. DOBRINICH #1
9967 Galleon Drive
West Palm Beach, FL 33411
UNKNOWN HEIR OF DOUGLAS M.
DOBRINICH #3
9967 Galleon Drive
West Palm Beach, FL 33411
LEHIGH ACRES PROPERTIES, LLC
9967 Galleon Drive
West Palm Beach, FL 33411
UNKNOWN HEIR OF DOUGLAS M.
DOBRINICH #2
9967 Galleon Drive
West Palm Beach, FL 33411
UNKNOWN HEIRS OF DOUGLAS
M. DOBRINICH #4
9967 Galleon Drive
West Palm Beach, FL 33411
YOU ARE NOTIFIED that an action
for Quiet Title has been filed against
you in relation to the following prop-
erties in Lee County, Florida:
Parcel 1

Lot 18, Block 4, Unit 1, Section
24, Township 44 South, Range
27 East, Lehigh Acres, Deed
Book 254, Page 50, Public Re-
cords of Lee County, Florida.
Parcel ID: 24-44-27-L-
01004.0180
Property Address: 811 Scott Ave-
nue, Lehigh Acres, FL 33972
Parcel 2
The East Half of Lot 12, Block
10, Unit 3, Section 21, Township
44 South, Range 27 East, Lehigh
Acres, according to the map or
plat thereof as recorded in Plat
Book 15, Page 30, Public Records
of Lee County, Florida.
Parcel ID: 21-44-27-L3-
03010.012B
Property Address: 903 East 8th
Street, Lehigh Acres, FL 33972
and you are required to serve a copy of
your written defenses, if any, to it on
Felix G. Montanez, Esq., the Plaintiff's
attorney, whose address is 2114 W. Co-
lumbus Dr., Tampa, FL 33607, on or be-
fore October 22, 2024, and file the origi-
nal with the clerk of this court either
before service on the plaintiff's attorney
or immediately thereafter; otherwise a
default will be entered against you for
the relief demanded in the complaint.
Date: 09/12/2024
Kevin C. Karnes
As Clerk of the Court
(SEAL) By: K Shoap
As Deputy Clerk
Felix G. Montanez, Esq.,
the Plaintiff's attorney,
2114 W. Columbus Dr.,
Tampa, FL 33607
Sept. 20, 27, Oct. 4, 11, 2024
24-03878L

SECOND INSERTION

NOTICE OF ACTION
IN THE COUNTY COURT OF THE
20th JUDICIAL CIRCUIT IN AND
FOR LEE COUNTY, FLORIDA
CIVIL ACTION
CASE NO. 2024-CC-5565
Judge: Nicole Lynn Mirra
RIVERS EDGE 2 CONDOMINIUM
ASSOCIATION, INC., a Florida
non-profit corporation,
Plaintiff, v.
JON C. ERICKSON, UNKNOWN
TENANT 1, UNKNOWN TENANT 2
and all others claiming by, through
or under JON C. ERICKSON,
Defendants.
RIVERS EDGE 2 CONDOMINIUM
ASSOCIATION, INC. v. JON C. ER-
ICKSON, et al.
TO: JON C. ERICKSON
Last Known Addresses: P.O. Box
60863, Fort Myers, FL 33906
14772 Olde Millpond Road, Fort Myers,
FL 33908
YOU ARE NOTIFIED that an action
to quiet title on the following property
in Lee County, Florida:
Condominium Parcel: Unit No.
3, of River's Edge 2, a Condo-
minium, according to the plat
thereof recorded in Condomini-
um Plat Book 11, page(s) 40, and
being further described in that
certain Declaration of Condo-
minium recorded in O.R. Book
1783, page 3649 et seq., together
with such additions and amend-
ments to said Declaration and
Condominium Plat as from time
to time may be made and togeth-
er with an undivided interest or
share in the common elements
appurtenant thereto. All as re-
corded in the Public Records of
Lee County, Florida.
Parcel ID: 31-45-24-39-
00000.0030; Folio ID:
10217537

Address: 14772 Olde Millpond
Road, Fort Myers, FL 33908
(the "Property").
has been filed against you and you
are required to serve a copy of your writ-
ten defenses by the Lee County Clerk
of Court's scheduled default date within
30 days on Bradley W. Butcher, Plain-
tiff's attorney, whose address is 6830
Porto Fino Circle, Ste. 2, Fort Myers,
Florida 33912 and file the original
with this Court either before service
on Plaintiff's attorney, or immediately
thereafter; otherwise a default will be
entered against you for the relief dem-
anded in the Complaint or petition.
This notice shall be published once a
week for four (4) consecutive weeks in
the Gulf Coast Business Review.
If you are a person with a disability
who needs any accommodation in order
to participate in this proceeding, you
are entitled, at no cost to you, to the
provision of certain assistance. Please
contact Brooke Dean, Operations Divi-
sion Manager, whose office is located at
Lee County Justice Center, 1700 Mon-
roe Street, Fort Myers, Florida 33901,
and whose telephone number is (239)
533-1771, at least 7 days before your
scheduled court appearance, or immedi-
ately upon receiving this notification
if the time before the scheduled appear-
ance is less than 7 days; if you are hear-
ing or voice impaired, call 711.
Dated this 13th day of September,
2024.
CLERK OF THE CIRCUIT COURT
KEVIN C. KARNES
Lee County Clerk of Court
(SEAL) By: K. Harris
ss Deputy Clerk
Butcher & Associates, P.L.
6830 Porto Fino Circle, Ste. 2
Fort Myers, Florida 33912
Sept. 20, 27, Oct. 4, 11, 2024
24-03895L

SECOND INSERTION

NOTICE OF ACTION
IN THE CIRCUIT COURT OF THE
TWENTIETH JUDICIAL CIRCUIT
IN AND FOR LEE COUNTY,
FLORIDA
CASE NO.: 24-CA-004695
ROCKET MORTGAGE, LLC F/K/A
QUICKEN LOANS, LLC F/K/A
QUICKEN LOANS INC.,
Plaintiff, v.
SHANTELE HUFF; UNKNOWN
SPOUSE OF SHANTELE HUFF;
GULF ATLANTIC FENCING
INC.; ALL UNKNOWN PARTIES
CLAIMING INTERESTS BY,
THROUGH, UNDER OR AGAINST
A NAMED DEFENDANT TO
THIS ACTION, OR HAVING OR
CLAIMING TO HAVE ANY RIGHT,
TITLE OR INTEREST IN THE
PROPERTY HEREIN DESCRIBED;
UNKNOWN TENANT #1;
UNKNOWN TENANT #2,
Defendant.
To the following Defendant(s):
SHANTELE HUFF
2144 NW 21st Ave
Cape Coral, FL 33993
UNKNOWN SPOUSE OF SHAN-
TELLE HUFF
2144 NW 21st Ave
Cape Coral, FL 33993
UNKNOWN TENANT #1
2144 NW 21st Ave
Cape Coral, FL 33993
UNKNOWN TENANT #2
2144 NW 21st Ave
Cape Coral, FL 33993
YOU ARE NOTIFIED that an action
for Foreclosure of Mortgage on the fol-
lowing described property:
LOT 46 AND 47, BLOCK 3890,
CAPE CORAL UNIT 53, AC-
CORDING TO THE MAP OR
PLAT THEREOF, AS RECOR-
DED IN PLAT BOOK 19, PAGE(S)
64 THROUGH 78, INCLUSIVE,
OF THE PUBLIC RECORDS OF

LEE COUNTY, FLORIDA.
a/k/a 2144 NW 21st Ave, Cape
Coral, FL 33993
has been filed against you and you
are required to serve a copy of your written
defenses, if any, upon Kelley Kronen-
berg, Attorney for Plaintiff, whose ad-
dress is 10360 West State Road 84, Fort
Lauderdale, FL 33324 within thirty
(30) days after the first publication of
this Notice in BUSINESS OBSERVER
and file the original with the Clerk
of this Court either before service on
Plaintiff's attorney or immediately
thereafter; otherwise a default will be
entered against you for the relief dem-
anded in the complaint.
This notice is provided pursuant to
Administrative Order No. 2.065.
If you are a person with a disability
who needs any accommodation in order
to participate in this proceeding, you
are entitled, at no cost to you, to the
provision of certain assistance. Please
contact Brooke Dean, Operations Divi-
sion Manager, whose office is located at
Lee County Justice Center, 1700 Mon-
roe Street, Fort Myers, Florida 33901,
and whose telephone number is (239)
533-1771, at least 7 days before your
scheduled court appearance, or immedi-
ately upon receiving this notification
if the time before the scheduled appear-
ance is less than 7 days; if you are hear-
ing or voice impaired, call 711.
WITNESS my hand and the seal of
this Court this day of 09/12/2024,
Kevin C. Karnes
As Clerk of the Court
(SEAL) By N. Watson
As Deputy Clerk
Kelley Kronenberg,
Attorney for Plaintiff,
10360 West State Road 84,
Fort Lauderdale, FL 33324
September 20, 27, 2024
24-03874L

NOTICE OF ACTION
IN THE CIRCUIT COURT OF THE
TWENTIETH JUDICIAL CIRCUIT,
IN AND FOR LEE COUNTY,
FLORIDA
CASE NO.: 24-CA-004314
BANK OF AMERICA, N.A.;
Plaintiff, vs.
UNKNOWN HEIRS,
BENEFICIARIES, DEVISEES,
SURVIVING SPOUSE, GRANTEEES,
ASSIGNEES, LIENORS,
CREDITORS, TRUSTEES AND
ALL OTHER PARTIES CLAIMING
AN INTEREST IN THE ESTATE
OF DONALD P. ALCORN A/K/A
DONALD PARK ALCORN;
ELIZABETH RICHARDSON
A/K/A ELIZABETH SUSAN
RICHARDSON; UNKNOWN
SPOUSE OF DONALD P. ALCORN
A/K/A DONALD PARK ALCORN;
UNKNOWN TENANT #1 IN
POSSESSION OF THE PROPERTY;
UNKNOWN TENANT #2 IN
POSSESSION OF THE PROPERTY;
Defendant(s).
To the following Defendant(s):
UNKNOWN HEIRS, BENEFICIA-
RIES, DEVISEES, SURVIVING
SPOUSE, GRANTEEES, ASSIGNEES,
LIENORS, CREDITORS, TRUSTEES
AND ALL OTHER PARTIES CLAIM-
ING AN INTEREST IN THE ESTATE
OF DONALD P. ALCORN A/K/A
DONALD PARK ALCORN
Last Known Address
unknown
UNKNOWN TENANT #1 IN POSSES-
SION OF THE PROPERTY
Last Known Address
4101 RAINBOW DR
FORT MYERS, FL 33916
UNKNOWN TENANT #2 IN POSSES-
SION OF THE PROPERTY
Last Known Address
4101 RAINBOW DR
FORT MYERS, FL 33916
YOU ARE NOTIFIED that an action
for Foreclosure of Mortgage on the fol-
lowing described property:
LOT 8, UNIT NO. 2 RAIN-
BOW GROVES, ACCORDING
TO THE PLAT THEREOF, AS

RECORDED IN PLAT BOOK
10, PAGE 4, OF THE PUBLIC
RECORDS OF LEE COUNTY,
FLORIDA.
a/k/a 4101 RAINBOW DR,
FORT MYERS, FL 33916 LEE
has been filed against you and you
are required to serve a copy of you writ-
ten defenses, if any, to it, on Marinosci
Law Group, P.C., Attorney for Plaintiff,
whose address is 100 W. Cypress Creek
Road, Suite 1045, Fort Lauderdale,
Florida 33309, within 30 days after
the first publication of this Notice in
the BUSINESS OBSERVER (GULF
COAST) and file the original with the
Clerk of this Court either before service
on Plaintiff's attorney or immediately
thereafter; otherwise a default will be
entered against you for the relief dem-
anded in the complaint.
This notice is provided pursuant to
Administrative Order No. 2.065.
If you are a person with a disability
who needs any accommodation in order
to participate in this proceeding, you
are entitled, at no cost to you, to the
provision of certain assistance. Please
contact Brooke Dean, Operations Divi-
sion Manager, whose office is located at
Lee County Justice Center, 1700 Mon-
roe Street, Fort Myers, Florida 33901,
and whose telephone number is (239)
533-1771, at least 7 days before your
scheduled court appearance, or immedi-
ately upon receiving this notification
if the time before the scheduled appear-
ance is less than 7 days; if you are hear-
ing or voice impaired, call 711.
WITNESS my hand and seal of this
Court this day of 09/11/2024,
Kevin C. Karnes
As Clerk of the Court by:
(SEAL) By: N. Watson
As Deputy Clerk
Submitted by:
Marinosci Law Group, P.C.
100 W. Cypress Creek Road, Suite 1045
Fort Lauderdale, FL 33309
Telephone: (954) 644-8704
Facsimile: (754) 206-1971
September 20, 27, 2024
24-03877L

SECOND INSERTION

NOTICE OF ACTION
IN THE CIRCUIT COURT OF THE
TWENTIETH JUDICIAL CIRCUIT
IN AND FOR LEE COUNTY,
FLORIDA
CASE NO.: 24-CA-005231
ALLIANT CREDIT UNION,
Plaintiff, vs.
KENNETH OFIERO; et al.,
Defendant(s).
TO: Kenneth Ofiero
Last Known Residence: 6899 Pentland
Way #114 Fort Myers, FL 33966
TO: Unknown Spouse of Kenneth
Ofiero
Last Known Residence: 6899 Pentland
Way #114 Fort Myers, FL 33966
YOU ARE NOTIFIED that an action
to foreclose a mortgage on the following
property in LEE County, Florida:
UNIT NO. 114, BUILDING 11
OF HEATHER RIDGE I OF
BROOKSHIRE, A CONDO-
MINIUM, ACCORDING TO
THE DECLARATION OF CON-
DOMINIUM RECORDED IN
O.R. BOOK 2011, PAGE 824,
AND ALL EXHIBITS AND

AMENDMENTS THEREOF,
PUBLIC RECORDS OF LEE
COUNTY, FLORIDA.
has been filed against you and you
are required to serve a copy of your written
defenses, if any, to it on ALDRIDGE
PITE, LLP, Plaintiff's attorney, at 5300
West Atlantic Avenue Suite 303 Delray
Beach, FL 33484, within 30 days, and
file the original with the clerk of this
court either before service on Plain-
tiff's attorney or immediately thereaf-
ter; otherwise a default will be entered
against you for the relief demanded in
the complaint or petition.
Dated on 09/18/2024.
Kevin C. Karnes
As Clerk of the Court
(SEAL) By: N. Watson
As Deputy Clerk
ALDRIDGE PITE, LLP,
Plaintiff's attorney,
5300 West Atlantic Avenue
Suite 303
Delray Beach, FL 33484
1100-976B
Ref# 9306
September 20, 27, 2024 24-03927L



SAVE TIME
Email your Legal Notice
legal@businessobserverfl.com • Deadline Wednesday at noon • Friday Publication

--- ACTIONS / SALES ---

SECOND INSERTION

NOTICE OF SALE AS TO COUNT(S) II

IN THE CIRCUIT COURT OF THE TWENTIETH JUDICIAL CIRCUIT, IN AND FOR LEE COUNTY, FLORIDA
Case No.: 23-CA-000024
Division: Civil
Judge Kyle S. Cohen
Plantation Condominium Association, Inc., a corporation not-for-profit under the laws of the State of Florida Plaintiff, vs.
Any and All Unknown Parties who claim an interest as spouse, heirs, devisees, grantees, assignees, lienors, creditors, trustees, personal representatives, administrators or as other claimants, by, through, under or against Salvatore Vincent Sanzone, deceased, et al. Defendants.

Notice is hereby given that on October 25, 2024 at 11:00 AM, offer by electronic sale at www.lee.realforeclose.com the following described Timeshare Ownership Interest:

Unit 5342L, Week 34, Even Year Biennial Coconut Plantation, a Condominium (the "Condominium"), according to the Declaration of Condominium thereof as recorded in Official Records Book 4033, Page 3816, Public Records of Lee County, Florida, and all exhibits attached thereto, and any amendments thereof (the "Declaration").

Any person claiming an interest in the surplus from this sale, if any, other than the property owner as of the date of the lis pendens must file a claim before the clerk reports the surplus as unclaimed.

The sale is being held pursuant to the Final Judgment of Foreclosure, entered on April 12, 2024, in Civil Case No. 23-CA-000024, pending in the Circuit Court in Lee County, Florida.

DATED this 09/17/2024
KEVIN C. KARNES
CLERK OF THE CIRCUIT COURT AND COMPTROLLER
LEE COUNTY, FLORIDA
(SEAL) By: N. Watson
Deputy Clerk

MANLEY DEAS KOCHALSKI LLC
P. O. Box 165028
Columbus, OH 43216-5028
AMPS@manleydeas.com
22-033057_MM2
September 20, 27, 2024 24-03922L

SECOND INSERTION

NOTICE OF ACTION FORECLOSURE PROCEEDINGS-PROPERTY

IN THE COUNTY COURT IN AND FOR LEE COUNTY, FLORIDA
CIVIL ACTION
Case #: 24-CC-004249

Wells Fargo Bank, N.A. Plaintiff, vs.-
Susan J. Moore a/k/a Susan Moore; Unknown Spouse of Susan J. Moore a/k/a Susan Moore; DLJ Mortgage Capital, Inc.; Parkwoods III Homeowners Association, Inc.; Unknown Parties in Possession #1, if living, and all Unknown Parties claiming by, through, under and against the above named Defendant(s); Unknown Parties in Possession #2, if living, and all Unknown Parties claiming by, through, under and against the above named Defendant(s) Defendant(s).

TO: Susan J. Moore a/k/a Susan Moore; LAST KNOWN ADDRESS: 1647 Park Meadow Drive, Unit 2, Fort Myers, FL 33907 and Unknown Spouse of Susan J. Moore a/k/a Susan Moore; LAST KNOWN ADDRESS: 1647 Park Meadow Drive, Unit 2, Fort Myers, FL 33907

Residence unknown, if living, including any unknown spouse of the said Defendants, if either has remarried and if either or both of said Defendants are dead, their respective unknown heirs, devisees, grantees, assignees, creditors, lienors, and trustees, and all other persons claiming by, through, under or against the named Defendant(s); and the aforementioned named Defendant(s) and such of the aforementioned unknown Defendants and such of the aforementioned unknown Defendants as may be infants, incompetents or otherwise not sui juris.

YOU ARE HEREBY NOTIFIED that an action has been commenced to foreclose a mortgage on the following real property, lying and being and situated in Lee County, Florida, more particularly described as follows:

FROM THE NORTHEAST CORNER OF THE NORTHWEST QUARTER (NW 1/4) OF SECTION 14, TOWNSHIP 45 SOUTH, RANGE 24 EAST, LEE COUNTY, FLORIDA, RUN S 89°18'30" W ALONG THE NORTH LINE OF SAID SECTION 14 FOR 133.71 FEET;

SECOND INSERTION

NOTICE OF SALE PURSUANT TO CHAPTER 45

IN THE CIRCUIT COURT OF THE TWENTIETH JUDICIAL CIRCUIT IN AND FOR LEE COUNTY, FLORIDA
CIVIL ACTION
CASE NO.: 36-2023-CA-003369

LAKEVIEW LOAN SERVICING, LLC, Plaintiff, vs.
MARY ALISON WAGGONER AKA MARY A. WAGGONER, et al, Defendant(s).

NOTICE IS HEREBY GIVEN Pursuant to a Final Judgment of Foreclosure dated July 19, 2024, and entered in Case No. 36-2023-CA-003369 of the Circuit Court of the Twentieth Judicial Circuit in and for Lee County, Florida in which Lakeview Loan Servicing, LLC, is the Plaintiff and Mary Alison Waggoner aka Mary A. Waggoner; Bonita Springs Country Club Civic Association, Incorporated a/k/a Bonita Springs Country Club Unit 1 Civic Association, Incorporated; are defendants, the Lee County Clerk of the Circuit Court will sell to the highest and best bidder for cash in/ on www.lee.realforeclose.com in accordance with chapter 45 Florida Statutes, Lee County, Florida at 9:00am on the 17th day of October, 2024, the following described property as set forth in said Final Judgment of Foreclosure:

LOT 67, BONITA SPRINGS COUNTRY CLUB UNIT 1, ACCORDING TO THE PLAT THEREOF AS RECORDED IN PLAT BOOK 30, PAGE 81, PUBLIC RECORDS OF LEE COUNTY, FLORIDA.
A/K/A 24881 CARNOUSTIE CT BONITA SPRINGS FL 34135

Any person claiming an interest in the surplus from the sale, if any, other than the property owner as of the date of the Lis Pendens must file a claim before the Clerk reports the surplus as unclaimed.

Dated in Lee County, Florida this day of 09/18/2024
Kevin C. Karnes
Clerk of the Circuit Court
Lee County, Florida
(SEAL) By: N. Watson
Deputy Clerk

Albertelli Law
Attorney for Plaintiff
P.O. Box 23028
Tampa, FL 33623
(813) 221-4743
(813) 221-9171 facsimile
eService:
servealaw@albertellilaw.com
CT - 23-001636
September 20, 27, 2024 24-03920L

SECOND INSERTION

AMENDED NOTICE OF FORECLOSURE SALE

IN THE CIRCUIT COURT OF THE TWENTIETH JUDICIAL CIRCUIT IN AND FOR LEE COUNTY, FLORIDA
CIVIL DIVISION
Case No. 23-CA-011958

Villas I At Vistanna Villas Association, Inc., Plaintiff, v.

Lawrence Chris Campbell; Eumphema Layne-Campbell; Castle Credit Co Holding, LLC; Goodleap, LLC, f/k/a Loanpal, LLC; Vistanna Villas Master Association Inc.; Unknown Person in Possession 1; and Unknown Person in Possession 2; et al. Defendants.

NOTICE IS HEREBY GIVEN that pursuant to the Final Judgment of Foreclosure dated 08/23/2024, and entered in case number 23-CA-011958 of the Circuit Court of the Twentieth Judicial Circuit in and for Lee County, Florida, wherein Villas I at Vistanna Villas Association, Inc. is the Plaintiff and Lawrence Chris Campbell; Eumphema Lanynne-Campbell; Castle Credit Co Holding, LLC; Vistanna Villas Master Association, Inc., Unknown in Possession 1, and Unknown in Possession 2 are Defendants, Kevin C. Karnes, Clerk of Court, will sell to the highest bidder for cash, at www.lee.realforeclose.com beginning at 9:00 am on October 10, 2024, the following described real property as set forth in the Final Judgment, to-wit:

LOT 219 VITANNA VILLAS, A SUBDIVISION, ACCORDING TO THE PLAT THEREOF AS RECORDED IN PLAT BOOK 82, PAGES 32 THROUGH 37, INCLUSIVE, OF THE PUBLIC RECORDS OF LEE COUNTY, FLORIDA.

Any person or entity claiming an interest in the surplus from the sale, if any, other than the property owner as of the date of the Lis Pendens must file a claim with the Clerk no later than the date that the Clerk reports the funds as unclaimed. If you fail to file a claim, you will not be entitled to any remaining funds.

If the sale is set aside, the Purchaser may be entitled to only a return of the sale deposit less any applicable fees and costs and shall have on other recourse against the Plaintiff, the Defendants, or the Plaintiff's counsel.

09/18/2024
Kevin C. Karnes
Clerk of Court
(SEAL) N. Watson

Joseph A. Bare, ESQ.
Attorney for Plaintiff
VARNUM, LLP
999 Vanderbilt Beach Rd, Ste 300
Naples, FL 34108
jabare@varnumlaw.com
Telephone (239) 373-8022
Fax (239) 241-7385
September 20, 27, 2024 24-03918L

SECOND INSERTION

NOTICE OF ACTION

IN THE CIRCUIT COURT OF THE TWENTIETH JUDICIAL CIRCUIT IN AND FOR LEE COUNTY, FLORIDA
CIVIL ACTION
CASE NO.: 24-CA-2469

BLUE OCEAN PROPERTIES, LLC Plaintiff, vs.
THE FLORIDA STORE, INC., ESTATE OF ANTONIO ROMANO, ESTATE OF FILOMENA ROMANO, SHARON S. GIDEONS, ROBERT D. GIDEONS, GOLDOME CREDIT CORPORATION, FRANCO ROMANO, WPL HOLDINGS LLC. Defendants.

TO THE DEFENDANT, THE FLORIDA STORE, INC.
YOU ARE HEREBY NOTIFIED that a Complaint has been filed on behalf of Plaintiff, BLUE OCEAN PROPERTIES, LLC, and you are required to serve a copy of your written defenses, if any, to it on Erik C. Stocks, Esquire, Plaintiffs' Attorney, of the law firm of Jones, Haber & Rollings, whose address is 1633 SE 47th Terrace, Cape Coral, Florida 33904 and file the original with the Clerk of this Court on or before October 22, 2024; otherwise the allegations of the Petition will be taken as confessed.

This Notice shall be published once a week for four consecutive weeks in Lee, Florida.

Dated: September 12, 2024
KEVIN C. KARNES
Clerk of Circuit Court
(SEAL) By: K Shoap
Deputy Clerk

Erik C. Stocks, Esquire,
Plaintiffs' Attorney,
The Law firm of Jones, Haber & Rollings
1633 SE 47th Terrace, Cape Coral, Florida 33904
Sept. 20, 27; Oct. 4, 11, 2024
24-03871L

SECOND INSERTION

NOTICE OF SALE

IN THE CIRCUIT COURT OF THE TWENTIETH JUDICIAL CIRCUIT IN AND FOR LEE COUNTY, FLORIDA
CIVIL DIVISION
CASE #: 22-CA-002726
DIVISION: I

Rocket Mortgage, LLC f/k/a Quicken Loans, LLC f/k/a Quicken Loans Inc. Plaintiff, vs.-
Jonathan T. Doucet; Unknown Spouse of Jonathan T. Doucet; United States of America, Acting Through the Secretary of Housing and Urban Development; Unknown Parties in Possession #1, if living, and all Unknown Parties claiming by, through, under and against the above named Defendant(s); Unknown Parties in Possession #2, if living, and all Unknown Parties claiming by, through, under and against the above named Defendant(s).

NOTICE IS HEREBY GIVEN pursuant to order rescheduling foreclosure sale or Final Judgment, entered in Civil Case No. 22-CA-002726 of the Circuit Court of the 20th Judicial Circuit in and for Lee County, Florida, wherein Rocket Mortgage, LLC f/k/a Quicken Loans, LLC f/k/a Quicken Loans Inc., Plaintiff and Jonathan T. Doucet are defendant(s), I, Clerk of Court, Kevin C. Karnes, will sell to the highest and best bidder for cash BEGINNING 9:00 A.M. AT WWW.LEE.REALFORECLOSE.COM IN ACCORDANCE WITH CHAPTER 45 FLORIDA STATUTES on December 12, 2024, the following described property as set forth in said Final Judgment, to-wit:

LOT 359 AND 360, BLOCK 9, GRANDA B.L.V.D. DELRAY AVE, KINGSTON DRIVE SECTIONS OF RUSSELL PARK, ACCORDING TO THE PLAT THEREOF, AS RECORDED IN PLAT BOOK 6, PAGE 12, OF THE PUBLIC RECORDS OF LEE COUNTY, FLORIDA.

ANY PERSON CLAIMING AN INTEREST IN THE SURPLUS FROM THE SALE, IF ANY, OTHER THAN THE PROPERTY OWNER AS OF THE DATE OF THE LIS PENDENS MUST FILE A CLAIM NO LATER THAN THE DATE THAT THE CLERK REPORTS THE FUNDS AS UNCLAIMED.

09/17/2024
Kevin C. Karnes
CLERK OF THE CIRCUIT COURT
Lee County, Florida
(SEAL) N. Watson

DEPUTY CLERK OF COURT
Submitted By:
ATTORNEY FOR PLAINTIFF:
LOGS LEGAL GROUP LLP
750 Park of Commerce Blvd., Suite 130
Boca Raton, Florida 33487
(561) 998-6700
(561) 998-6707
22-326804 FCO1 RFT
September 20, 27, 2024 24-03919L

SECOND INSERTION

NOTICE OF ACTION

IN THE CIRCUIT COURT OF THE TWENTIETH JUDICIAL CIRCUIT IN AND FOR LEE COUNTY, FLORIDA
CIVIL ACTION
CASE NO.: 24-DR-4167

IN RE: The Marriage of CHRISTOPHER L. LYNCH Petitioner, and PEARL LYNCH, Respondent.

TO: PEARL LYNCH
2057 Long Lake Road
Fenton, MI 48430

YOU ARE HEREBY notified that a lawsuit has been filed against you in the Lee County Court in the above-styled case. You are required to serve a copy of your answer to the Petition on the Petitioner's attorney TRISHA L. RYAN, Lusk, Drasites & Tolisano, P.A., Post Office Box 151207, Cape Coral, Florida 33915-1207 and file the original in the office of the Clerk of the Circuit Court within 30 days after the first date of publication otherwise the allegations of the Petition will be taken as confessed. Response Due Date: October 21, 2024 Lee County Clerk's Office address: 1700 Monroe Street, Fort Myers, FL 33901

This Notice shall be published once a week for four consecutive weeks in The Business Observer, Lee County, Florida. Dated this 11th day of September, 2024.

Kevin C. Karnes
Clerk of the Circuit Court
(SEAL) By: J. Collins
Deputy Clerk

TRISHA L. RYAN,
Lusk, Drasites & Tolisano, P.A.,
Post Office Box 151207,
Cape Coral, Florida 33915-1207
Sept. 20, 27; Oct. 4, 11, 2024
24-03876L

SECOND INSERTION

NOTICE OF ACTION

IN THE CIRCUIT COURT OF THE TWENTIETH JUDICIAL CIRCUIT JUDICIAL CIRCUIT, IN AND FOR LEE COUNTY, FLORIDA
CIVIL DIVISION
CASE NO.: 23-CA-007663

FREEDOM MORTGAGE CORPORATION PLAINTIFF, VS.

UNKNOWN HEIRS, BENEFICIARIES, DEVISEES, ASSIGNEES, LIENORS, CREDITORS, TRUSTEES, AND ALL OTHERS WHO MAY CLAIM AN INTEREST IN THE ESTATE OF RONALD R. MORELLO, ET AL., DEFENDANT(S).

TO: Unknown heirs, beneficiaries, devisees, assignees, lienors, creditors, trustees, and all others who may claim an interest in the estate of Ronald R. Morello
Last Known Address: 1304 Islamorada Blvd, Punta Gorda, FL 33955
Current Residence: UNKNOWN
TO: Brynn Roanna Skinner A/K/A Brynn Skinner
Last Known Address: 4304 Islamorada Blvd., Punta Gorda, FL 33955
Current Residence: UNKNOWN

YOU ARE NOTIFIED that an action for Foreclosure of Mortgage on the following described property:

Unit 13, Courtyard Landings II Condominium, according to plat thereof recorded in Condominium Plat Book 19, page 69, amended in Condominium Plat Book 19, Page 83, and subsequent amendments thereto; and being further described in that certain Declaration of Condominium recorded in Official Records Book 2384, Page 3427, and subsequent amendments

thereto, Public Records of Lee County, Florida.

has been filed against you and you are required to serve a copy of your written defenses, if any, to it, on MILLER, GEORGE & SUGGS, PLLC, Attorney for Plaintiff, whose address is 210 N. University Drive, Suite 900, Coral Springs, FL 33071, within thirty (30) days after the first publication of this Notice in the The Business Observer, 1970 Main Street, 3rd Floor, Sarasota, FL 34236 and file the original with the Clerk of this Court either before service on Plaintiff's attorney or immediately thereafter; otherwise a default will be entered against you for the relief demanded in the complaint

If you are a person with a disability who needs any accommodation in order to participate in this proceeding, you are entitled, at no cost to you, to the provision of certain assistance. Please contact Brooke Dean, Operations Division Manager, whose office is located at Lee County Justice Center, 1700 Monroe Street, Fort Myers, Florida 33901, and whose telephone number is (239) 533-1771, at least 7 days before your scheduled court appearance, or immediately upon receiving this notification if the time before the scheduled appearance is less than 7 days; if you are hearing or voice impaired, call 711.

WITNESS my hand and the seal of this Court this 12 day of September, 2024.

Kevin C. Karnes
As Clerk of Court
(SEAL) By: K. Shoap
As Deputy Clerk

MILLER, GEORGE & SUGGS, PLLC,
Attorney for Plaintiff,
210 N. University Drive,
Suite 900,
Coral Springs, FL 33071,
September 20, 27, 2024 24-03872L

SECOND INSERTION

NOTICE OF ACTION

IN THE CIRCUIT COURT OF THE TWENTIETH JUDICIAL CIRCUIT IN AND FOR LEE COUNTY, FLORIDA
CIVIL ACTION
CASE NO.: 24-CA-004547

BANK OF AMERICA, N.A., Plaintiff, vs.
THE UNKNOWN HEIRS, DEVISEES, GRANTEES, ASSIGNEES, LIENORS, CREDITORS, TRUSTEES, OR OTHER CLAIMANTS CLAIMING BY, THROUGH, UNDER, OR AGAINST, LINDA SORENSEN AKA LINDA ANNE SORENSEN, DECEASED, et al, Defendant(s).

TO: THE UNKNOWN HEIRS, DEVISEES, GRANTEES, ASSIGNEES, LIENORS, CREDITORS, TRUSTEES, OR OTHER CLAIMANTS CLAIMING BY, THROUGH, UNDER, OR AGAINST, LINDA SORENSEN AKA LINDA ANNE SORENSEN, DECEASED

Last Known Address: Unknown
Current Address: Unknown

YOU ARE NOTIFIED that an action to foreclose a mortgage on the following property in Lee County, Florida:

LOTS 63 AND 64, BLOCK 3540, UNIT 47, PART 2, CAPE CORAL SUBDIVISION, ACCORDING TO THE PLAT THEREOF RECORDED IN PLAT BOOK 23, PAGES 112 THROUGH 127, INCLUSIVE, PUBLIC RECORDS OF LEE COUNTY, FLORIDA.
A/K/A 1739 NE 12TH TER

CAPE CORAL FL 33909 has been filed against you and you are required to file written defenses with the clerk of court and to serve a copy within 30 days after the first publication of the Notice of Action, on Albertelli Law, Plaintiff's attorney, whose address is P.O. Box 23028, Tampa, FL 33623; otherwise, a default will be entered against you for the relief demanded in the Complaint or petition.

This notice shall be published once a week for two consecutive weeks in the Business Observer.

If you are a person with a disability who needs any accommodation in order to participate in this proceeding, you are entitled, at no cost to you, to the provision of certain assistance. Please contact Brooke Dean, Operations Division Manager, whose office is located at Lee County Justice Center, 1700 Monroe Street, Fort Myers, Florida 33901, and whose telephone number is (239) 533-1771, at least 7 days before your scheduled court appearance, or immediately upon receiving this notification if the time before the scheduled appearance is less than 7 days; if you are hearing or voice impaired, call 711.

WITNESS my hand and the seal of this court on this day of 09/12/2024

Kevin C. Karnes
Clerk of the Circuit Court
(SEAL) By: N. Watson
Deputy Clerk

Albertelli Law
P.O. Box 23028
Tampa, FL 33623
AR-24-008605
September 20, 27, 2024 24-03867L

SECOND INSERTION

NOTICE OF ACTION

IN THE CIRCUIT COURT OF THE TWENTIETH JUDICIAL CIRCUIT IN AND FOR LEE COUNTY, FLORIDA
CASE NO. 24-CA-004500

MIDFIRST BANK Plaintiff, v.

LINDA P. JORDAN JONES A/K/A LINDA PEARL JORDAN JONES A/K/A LINDA P. JORDAN A/K/A LINDA PEARL JORDAN A/K/A LINDA P. JONES A/K/A LINDA J. JONES, ET AL. Defendants.

TO: LINDA P. JORDAN JONES A/K/A LINDA PEARL JORDAN JONES A/K/A LINDA P. JORDAN A/K/A LINDA PEARL JORDAN A/K/A LINDA P. JONES A/K/A LINDA J. JONES, Current residence unknown, but whose last known address was: 4915 BYWOOD ST, LEHIGH ACRES, FL 33971-6589

YOU ARE NOTIFIED that an action to foreclose a mortgage on the following property in Lee County, Florida, to-wit:

LOT 2, BLOCK 95, UNIT 14, LEHIGH ACRES, SECTION 29, TOWNSHIP 44 SOUTH, RANGE 26 EAST, LEHIGH ACRES, ACCORDING TO THE PLAT THEREOF RECORDED IN PLAT BOOK 26, PAGE 49, OF THE PUBLIC RECORDS OF LEE COUNTY, FLORIDA.

has been filed against you and you are required to serve a copy of your written defenses, if any, to it on eXL Legal, PLLC, Plaintiff's attorney, whose ad-

dress is 12425 28th Street North, Suite 200, St. Petersburg, FL 33716, within thirty (30) days after the first publication of this Notice of Action, and file the original with the Clerk of this Court at P.O. Box 310, Ft. Myers, FL 33902, either before service on Plaintiff's attorney or immediately thereafter; otherwise, a default will be entered against you for the relief demanded in the complaint petition.

If you are a person with a disability who needs any accommodation in order to participate in this proceeding, you are entitled, at no cost to you, to the provision of certain assistance. Please contact Brooke Dean, Operations Division Manager, whose office is located at Lee County Justice Center, 1700 Monroe Street, Fort Myers, Florida 33901, and whose telephone number is (239) 533-1771, at least 7 days before your scheduled court appearance, or immediately upon receiving this notification if the time before the scheduled appearance is less than 7 days; if you are hearing or voice impaired, call 711.

WITNESS my hand and the seal of the Court this day of 09/11/2024

Kevin C. Karnes
Clerk of the Circuit Court
(SEAL) By: N. Watson
Deputy Clerk

eXL Legal, PLLC,
Plaintiff's attorney,
12425 28th Street North,
Suite 200,
St. Petersburg, FL 33716
1000010272
September 20, 27, 2024 24-03870L

SUBSCRIBE TO THE BUSINESS OBSERVER
Call: (941) 362-4848 or go to: www.businessobserverfl.com
Business Observer logo

--- TAX DEEDS ---

THIRD INSERTION
NOTICE OF APPLICATION FOR TAX DEED
Section 197.512 F.S.
 Tax Deed #:2024000961
 NOTICE IS HEREBY GIVEN that Savvy FL LLC First Horizon Collateral Assignee the holder of the following certificate(s) has filed said certificate(s) for a tax deed to be issued thereon. The certificate number(s), year(s) of issuance, the description of the property and the name(s) in which it was assessed are as follows:
 Certificate Number: 18-708 Year of Issuance 2022 Description of Property LEHIGH ACRES UNIT 9 BLK 56 PB 15 PG 199 LOT 1 Strap Number 02-45-27-09-00056.0010
 Names in which assessed: CARLSSON OVE
 All of said property being in the County of Lee, State of Florida. Unless such certificate(s) shall be redeemed according to the law the property described in such certificate(s) will be sold to the highest bidder online at www.lee.realtaxdeed.com on 11/05/2024 at 10:00 am, by Kevin C. Karnes, Lee County Clerk of the Circuit Court & Comptroller.
 Sept. 13, 20, 27; Oct. 4, 2024
 24-03783L

THIRD INSERTION
NOTICE OF APPLICATION FOR TAX DEED
Section 197.512 F.S.
 Tax Deed #:2024001137
 NOTICE IS HEREBY GIVEN that TEN EAGLES LLC the holder of the following certificate(s) has filed said certificate(s) for a tax deed to be issued thereon. The certificate number(s), year(s) of issuance, the description of the property and the name(s) in which it was assessed are as follows:
 Certificate Number: 18-715 Year of Issuance 2022 Description of Property LEHIGH ACRES UNIT 10 BLK 58 PB 15 PG 200 LOT 2 Strap Number 02-45-27-10-00058.0020
 Names in which assessed: JOSEPH OWSLEY, VIRGINIA L OWSLEY
 All of said property being in the County of Lee, State of Florida. Unless such certificate(s) shall be redeemed according to the law the property described in such certificate(s) will be sold to the highest bidder online at www.lee.realtaxdeed.com on 11/05/2024 at 10:00 am, by Kevin C. Karnes, Lee County Clerk of the Circuit Court & Comptroller.
 Sept. 13, 20, 27; Oct. 4, 2024
 24-03784L

THIRD INSERTION
NOTICE OF APPLICATION FOR TAX DEED
Section 197.512 F.S.
 Tax Deed #:2024001179
 NOTICE IS HEREBY GIVEN that Mikon Financial Services Inc and Ocean Bank the holder of the following certificate(s) has filed said certificate(s) for a tax deed to be issued thereon. The certificate number(s), year(s) of issuance, the description of the property and the name(s) in which it was assessed are as follows:
 Certificate Number: 18-743 Year of Issuance 2022 Description of Property LEHIGH ACRES UNIT 12 BLK 74 PB 15 PG 204 LOT 12 Strap Number 02-45-27-12-00074.0120
 Names in which assessed: TARPON IV, LLC
 All of said property being in the County of Lee, State of Florida. Unless such certificate(s) shall be redeemed according to the law the property described in such certificate(s) will be sold to the highest bidder online at www.lee.realtaxdeed.com on 11/05/2024 at 10:00 am, by Kevin C. Karnes, Lee County Clerk of the Circuit Court & Comptroller.
 Sept. 13, 20, 27; Oct. 4, 2024
 24-03785L

THIRD INSERTION
NOTICE OF APPLICATION FOR TAX DEED
Section 197.512 F.S.
 Tax Deed #:2024001024
 NOTICE IS HEREBY GIVEN that Savvy FL LLC First Horizon Collateral Assignee the holder of the following certificate(s) has filed said certificate(s) for a tax deed to be issued thereon. The certificate number(s), year(s) of issuance, the description of the property and the name(s) in which it was assessed are as follows:
 Certificate Number: 19-171 Year of Issuance 2022 Description of Property SOUTHWOOD UNIT 22 BLK 109 PB 26 PG 85 LOT 15 Strap Number 08-45-27-22-00109.0150
 Names in which assessed: MAI PHUNG
 All of said property being in the County of Lee, State of Florida. Unless such certificate(s) shall be redeemed according to the law the property described in such certificate(s) will be sold to the highest bidder online at www.lee.realtaxdeed.com on 11/05/2024 at 10:00 am, by Kevin C. Karnes, Lee County Clerk of the Circuit Court & Comptroller.
 Sept. 13, 20, 27; Oct. 4, 2024
 24-03787L

THIRD INSERTION
NOTICE OF APPLICATION FOR TAX DEED
Section 197.512 F.S.
 Tax Deed #:2024001445
 NOTICE IS HEREBY GIVEN that Morning Star One LLC the holder of the following certificate(s) has filed said certificate(s) for a tax deed to be issued thereon. The certificate number(s), year(s) of issuance, the description of the property and the name(s) in which it was assessed are as follows:
 Certificate Number: 20-73 Year of Issuance 2022 Description of Property CAPE CORAL UNIT 38 BLK 2655 PB 16 PG 97 LOTS 8 + 9 Strap Number 02-44-23-C1-02655.0080
 Names in which assessed: 5 DIAMOND DEVELOPMENT, LLC
 All of said property being in the County of Lee, State of Florida. Unless such certificate(s) shall be redeemed according to the law the property described in such certificate(s) will be sold to the highest bidder online at www.lee.realtaxdeed.com on 11/05/2024 at 10:00 am, by Kevin C. Karnes, Lee County Clerk of the Circuit Court & Comptroller.
 Sept. 13, 20, 27; Oct. 4, 2024
 24-03790L

THIRD INSERTION
NOTICE OF APPLICATION FOR TAX DEED
Section 197.512 F.S.
 Tax Deed #:2024001007
 NOTICE IS HEREBY GIVEN that Savvy FL LLC First Horizon Collateral Assignee the holder of the following certificate(s) has filed said certificate(s) for a tax deed to be issued thereon. The certificate number(s), year(s) of issuance, the description of the property and the name(s) in which it was assessed are as follows:
 Certificate Number: 21-89 Year of Issuance 2022 Description of Property CAPE CORAL UNIT 41 BLK 2871 PB 17 PG 9 LOTS 75 + 76 Strap Number 03-44-23-C1-02871.0750
 Names in which assessed: ELLAWISH LLC
 All of said property being in the County of Lee, State of Florida. Unless such certificate(s) shall be redeemed according to the law the property described in such certificate(s) will be sold to the highest bidder online at www.lee.realtaxdeed.com on 11/05/2024 at 10:00 am, by Kevin C. Karnes, Lee County Clerk of the Circuit Court & Comptroller.
 Sept. 13, 20, 27; Oct. 4, 2024
 24-03792L

THIRD INSERTION
NOTICE OF APPLICATION FOR TAX DEED
Section 197.512 F.S.
 Tax Deed #:2024000646
 NOTICE IS HEREBY GIVEN that Mikon Financial Services Inc and Ocean Bank the holder of the following certificate(s) has filed said certificate(s) for a tax deed to be issued thereon. The certificate number(s), year(s) of issuance, the description of the property and the name(s) in which it was assessed are as follows:
 Certificate Number: 22-262 Year of Issuance 2022 Description of Property LEHIGH ACRES UNIT 5 BLK 23 PB 20 PG 59 LOT 11 Strap Number 28-45-27-05-00023.0110
 Names in which assessed: ARLINGTON 42 LLC
 All of said property being in the County of Lee, State of Florida. Unless such certificate(s) shall be redeemed according to the law the property described in such certificate(s) will be sold to the highest bidder online at www.lee.realtaxdeed.com on 11/05/2024 at 10:00 am, by Kevin C. Karnes, Lee County Clerk of the Circuit Court & Comptroller.
 Sept. 13, 20, 27; Oct. 4, 2024
 24-03793L

THIRD INSERTION
NOTICE OF APPLICATION FOR TAX DEED
Section 197.512 F.S.
 Tax Deed #:2024001180
 NOTICE IS HEREBY GIVEN that Mikon Financial Services Inc and Ocean Bank the holder of the following certificate(s) has filed said certificate(s) for a tax deed to be issued thereon. The certificate number(s), year(s) of issuance, the description of the property and the name(s) in which it was assessed are as follows:
 Certificate Number: 22-70 Year of Issuance 2022 Description of Property CAPE CORAL UNIT 41 BLK 2894 PB 17 PG 6 LOTS 17 + 18 Strap Number 03-44-23-C4-02894.0170
 Names in which assessed: MARTHA CECILIA OROZCO
 All of said property being in the County of Lee, State of Florida. Unless such certificate(s) shall be redeemed according to the law the property described in such certificate(s) will be sold to the highest bidder online at www.lee.realtaxdeed.com on 11/05/2024 at 10:00 am, by Kevin C. Karnes, Lee County Clerk of the Circuit Court & Comptroller.
 Sept. 13, 20, 27; Oct. 4, 2024
 24-03794L

THIRD INSERTION
NOTICE OF APPLICATION FOR TAX DEED
Section 197.512 F.S.
 Tax Deed #:2024000793
 NOTICE IS HEREBY GIVEN that Mikon Financial Services Inc and Ocean Bank the holder of the following certificate(s) has filed said certificate(s) for a tax deed to be issued thereon. The certificate number(s), year(s) of issuance, the description of the property and the name(s) in which it was assessed are as follows:
 Certificate Number: 23-8 Year of Issuance 2022 Description of Property CAPE CORAL UNIT 83 BLK 5196 PB 23 PG 51 LOTS 38 + 39 Strap Number 25-43-22-C1-05196.0380
 Names in which assessed: IRIS C WELDS
 All of said property being in the County of Lee, State of Florida. Unless such certificate(s) shall be redeemed according to the law the property described in such certificate(s) will be sold to the highest bidder online at www.lee.realtaxdeed.com on 11/05/2024 at 10:00 am, by Kevin C. Karnes, Lee County Clerk of the Circuit Court & Comptroller.
 Sept. 13, 20, 27; Oct. 4, 2024
 24-03795L

THIRD INSERTION
NOTICE OF APPLICATION FOR TAX DEED
Section 197.512 F.S.
 Tax Deed #:2024000776
 NOTICE IS HEREBY GIVEN that Mikon Financial Services Inc and Ocean Bank the holder of the following certificate(s) has filed said certificate(s) for a tax deed to be issued thereon. The certificate number(s), year(s) of issuance, the description of the property and the name(s) in which it was assessed are as follows:
 Certificate Number: 45-08 Year of Issuance 2022 Description of Property CAPE CORAL UNIT 88 BLK 5800 PB 24 PG 136 LOTS 55 + 56 Strap Number 17-43-24-C2-05800.0550
 Names in which assessed: MONSANTO GROUP LLC
 All of said property being in the County of Lee, State of Florida. Unless such certificate(s) shall be redeemed according to the law the property described in such certificate(s) will be sold to the highest bidder online at www.lee.realtaxdeed.com on 11/05/2024 at 10:00 am, by Kevin C. Karnes, Lee County Clerk of the Circuit Court & Comptroller.
 Sept. 13, 20, 27; Oct. 4, 2024
 24-03797L

THIRD INSERTION
NOTICE OF APPLICATION FOR TAX DEED
Section 197.512 F.S.
 Tax Deed #:2024001202
 NOTICE IS HEREBY GIVEN that Mikon Financial Services Inc and Ocean Bank the holder of the following certificate(s) has filed said certificate(s) for a tax deed to be issued thereon. The certificate number(s), year(s) of issuance, the description of the property and the name(s) in which it was assessed are as follows:
 Certificate Number: 59-87 Year of Issuance 2022 Description of Property CAPE CORAL UNIT 31 BLK 2010 PB 14 PG 151 LOT 5 Strap Number 07-44-24-C1-02010.0050
 Names in which assessed: LEVENTURES LLC
 All of said property being in the County of Lee, State of Florida. Unless such certificate(s) shall be redeemed according to the law the property described in such certificate(s) will be sold to the highest bidder online at www.lee.realtaxdeed.com on 11/05/2024 at 10:00 am, by Kevin C. Karnes, Lee County Clerk of the Circuit Court & Comptroller.
 Sept. 13, 20, 27; Oct. 4, 2024
 24-03801L

THIRD INSERTION
NOTICE OF APPLICATION FOR TAX DEED
Section 197.512 F.S.
 Tax Deed #:2024001200
 NOTICE IS HEREBY GIVEN that Mikon Financial Services Inc and Ocean Bank the holder of the following certificate(s) has filed said certificate(s) for a tax deed to be issued thereon. The certificate number(s), year(s) of issuance, the description of the property and the name(s) in which it was assessed are as follows:
 Certificate Number: 59-88 Year of Issuance 2022 Description of Property CAPE CORAL UNIT 31 BLK 2010 PB 14 PG 151 LOT 6 Strap Number 07-44-24-C1-02010.0060
 Names in which assessed: Hudson Ventures LLC
 All of said property being in the County of Lee, State of Florida. Unless such certificate(s) shall be redeemed according to the law the property described in such certificate(s) will be sold to the highest bidder online at www.lee.realtaxdeed.com on 11/05/2024 at 10:00 am, by Kevin C. Karnes, Lee County Clerk of the Circuit Court & Comptroller.
 Sept. 13, 20, 27; Oct. 4, 2024
 24-03802L

THIRD INSERTION
NOTICE OF APPLICATION FOR TAX DEED
Section 197.512 F.S.
 Tax Deed #:2024001135
 NOTICE IS HEREBY GIVEN that TEN EAGLES LLC the holder of the following certificate(s) has filed said certificate(s) for a tax deed to be issued thereon. The certificate number(s), year(s) of issuance, the description of the property and the name(s) in which it was assessed are as follows:
 Certificate Number: 18-441 Year of Issuance 2022 Description of Property LEHIGH ACRES UNIT 2 BLK 15 PB 15 PG 171 LOT 15 Strap Number 01-45-27-02-00015.0150
 Names in which assessed: SHARYL SCHULTZ
 All of said property being in the County of Lee, State of Florida. Unless such certificate(s) shall be redeemed according to the law the property described in such certificate(s) will be sold to the highest bidder online at www.lee.realtaxdeed.com on 11/05/2024 at 10:00 am, by Kevin C. Karnes, Lee County Clerk of the Circuit Court & Comptroller.
 Sept. 13, 20, 27; Oct. 4, 2024
 24-03780L

THIRD INSERTION
NOTICE OF APPLICATION FOR TAX DEED
Section 197.512 F.S.
 Tax Deed #:2024001201
 NOTICE IS HEREBY GIVEN that Mikon Financial Services Inc and Ocean Bank the holder of the following certificate(s) has filed said certificate(s) for a tax deed to be issued thereon. The certificate number(s), year(s) of issuance, the description of the property and the name(s) in which it was assessed are as follows:
 Certificate Number: 59-89 Year of Issuance 2022 Description of Property CAPE CORAL UNIT 31 BLK 2010 PB 14 PG 151 LOT 02010.0070
 Names in which assessed: LEVENTURES LLC
 All of said property being in the County of Lee, State of Florida. Unless such certificate(s) shall be redeemed according to the law the property described in such certificate(s) will be sold to the highest bidder online at www.lee.realtaxdeed.com on 11/05/2024 at 10:00 am, by Kevin C. Karnes, Lee County Clerk of the Circuit Court & Comptroller.
 Sept. 13, 20, 27; Oct. 4, 2024
 24-03803L

THIRD INSERTION
NOTICE OF APPLICATION FOR TAX DEED
Section 197.512 F.S.
 Tax Deed #:2024001023
 NOTICE IS HEREBY GIVEN that Savvy FL LLC First Horizon Collateral Assignee the holder of the following certificate(s) has filed said certificate(s) for a tax deed to be issued thereon. The certificate number(s), year(s) of issuance, the description of the property and the name(s) in which it was assessed are as follows:
 Certificate Number: 83-33 Year of Issuance 2022 Description of Property ARLINGTON PB 16 PG 38-39 LOT 95 Strap Number 08-44-25-P3-04800.0950
 Names in which assessed: MARIA JIMENEZ JOSE TOMAS
 All of said property being in the County of Lee, State of Florida. Unless such certificate(s) shall be redeemed according to the law the property described in such certificate(s) will be sold to the highest bidder online at www.lee.realtaxdeed.com on 11/05/2024 at 10:00 am, by Kevin C. Karnes, Lee County Clerk of the Circuit Court & Comptroller.
 Sept. 13, 20, 27; Oct. 4, 2024
 24-03806L

THIRD INSERTION
NOTICE OF APPLICATION FOR TAX DEED
Section 197.512 F.S.
 Tax Deed #:2024001198
 NOTICE IS HEREBY GIVEN that Mikon Financial Services Inc and Ocean Bank the holder of the following certificate(s) has filed said certificate(s) for a tax deed to be issued thereon. The certificate number(s), year(s) of issuance, the description of the property and the name(s) in which it was assessed are as follows:
 Certificate Number: 84-3 Year of Issuance 2022 Description of Property CAPE CORAL UNIT 97 BLK 6105 PB 25 PG 92 LOTS 6 + 7 Strap Number 07-43-23-C4-06105.0060
 Names in which assessed: TARPON IV LLC
 All of said property being in the County of Lee, State of Florida. Unless such certificate(s) shall be redeemed according to the law the property described in such certificate(s) will be sold to the highest bidder online at www.lee.realtaxdeed.com on 11/05/2024 at 10:00 am, by Kevin C. Karnes, Lee County Clerk of the Circuit Court & Comptroller.
 Sept. 13, 20, 27; Oct. 4, 2024
 24-03807L

THIRD INSERTION
NOTICE OF APPLICATION FOR TAX DEED
Section 197.512 F.S.
 Tax Deed #:2024001018
 NOTICE IS HEREBY GIVEN that Savvy FL LLC First Horizon Collateral Assignee the holder of the following certificate(s) has filed said certificate(s) for a tax deed to be issued thereon. The certificate number(s), year(s) of issuance, the description of the property and the name(s) in which it was assessed are as follows:
 Certificate Number: 69-32 Year of Issuance 2022 Description of Property CCBC-CAPE CORAL BOAT CLUB AS DESC IN INST #2011000214570 UNIT 220 Strap Number 07-45-24-C3-06100.0220
 Names in which assessed: PORT 32 CAPE CORAL LLC
 All of said property being in the County of Lee, State of Florida. Unless such certificate(s) shall be redeemed according to the law the property described in such certificate(s) will be sold to the highest bidder online at www.lee.realtaxdeed.com on 11/05/2024 at 10:00 am, by Kevin C. Karnes, Lee County Clerk of the Circuit Court & Comptroller.
 Sept. 13, 20, 27; Oct. 4, 2024
 24-03805L

THIRD INSERTION
NOTICE OF APPLICATION FOR TAX DEED
Section 197.512 F.S.
 Tax Deed #:2024000787
 NOTICE IS HEREBY GIVEN that Mikon Financial Services Inc and Ocean Bank the holder of the following certificate(s) has filed said certificate(s) for a tax deed to be issued thereon. The certificate number(s), year(s) of issuance, the description of the property and the name(s) in which it was assessed are as follows:
 Certificate Number: 65-1 Year of Issuance 2022 Description of Property PARR IN S E 1/4 OF SW 1/4 AS DESC IN OR 1131 PG 1520 Strap Number 22-45-22-01-00000.0130
 Names in which assessed: 1 PALM VILLAGE INVESTMENT LLC
 All of said property being in the County of Lee, State of Florida. Unless such certificate(s) shall be redeemed according to the law the property described in such certificate(s) will be sold to the highest bidder online at www.lee.realtaxdeed.com on 11/05/2024 at 10:00 am, by Kevin C. Karnes, Lee County Clerk of the Circuit Court & Comptroller.
 Sept. 13, 20, 27; Oct. 4, 2024
 24-03804L

FOURTH INSERTION
NOTICE OF ACTION; CONSTRUCTIVE SERVICE - PROPERTY
 IN THE CIRCUIT COURT OF THE TWENTIETH JUDICIAL CIRCUIT OF THE STATE OF FLORIDA, IN AND FOR LEE COUNTY, CIVIL DIVISION
CASE NO.: 2024-CA-004885
INVEST READY PROPERTIES, LLC,
Plaintiff, vs.
RAUL R. SALINAS,
Defendant.
 TO: Estate of Raul R. Salinas, 407 Girard Ave, Pembroke, NH 03275 Unknown Heirs of Raul R. Salinas, 407 Girard Ave, Pembroke, NH 03275
 YOU ARE NOTIFIED that an action to quiet title to the following properties in Lee County, Florida:
 Lot 1, Block 20, Unit 5, Section 21, Township 44 South, Range 27 East, Lehigh Acres according to the map or plat thereof on file in the office of the Clerk of the Circuit Court, recorded in Plat Book 15, Page 30, Public Records, Lee County, Florida.
 Parcel ID: 21-44-27-05-00020.0010
 has been filed against you and you are required to serve a copy of your written defenses, if any, to it on Sokolof Remtulla, LLP, the plaintiff's attorney, whose address is 6801 Lake Worth Road, Suite 100E, Greenacres, FL 33467, on or before October 9, 2024, and file the original with the clerk of this court either before service on the plaintiff's attorney or immediately thereafter; otherwise a default will be entered against you for the relief demanded in the complaint or petition.
 DATED on 08/30/2024
 Kevin C. Karnes
 CLERK OF THE CIRCUIT COURT (SEAL) By: K. Harris DEPUTY CLERK
 SOKOLOF REMTULLA, LLP
 6801 Lake Worth Road, Suite 100E Greenacres, FL 33467
 Telephone: 561-507-5252
 Facsimile: 561-342-4842
 E-mail: pleadings@sokrem.com
 Counsel for Plaintiff
 September 6, 13, 20, 27, 2024
 24-03726L

FOURTH INSERTION
NOTICE OF ACTION FOR PUBLICATION
 IN THE CIRCUIT COURT OF THE TWENTIETH JUDICIAL CIRCUIT, IN AND FOR LEE COUNTY, FLORIDA
Case No.: 24-DR-3747
Division: FAMILY
IN RE THE MARRIAGE OF: CARA ANN CLARK, Petitioner, and JEFFERY CLARK, Respondent.
 TO: JEFFERY CLARK
 YOU ARE NOTIFIED that an action for Dissolution of Marriage, including claims for dissolution of marriage, payment of debts, division of real and personal property, and for payments of support, has been filed against you. You are required to serve a copy of your written defenses, if any, to this action on Michele Belmont, of Belmont Law Group, Petitioner's attorney, whose address is 8270 College Parkway, #201, Fort Myers, FL 33919, on or before October 9, 2024, and file the original with the clerk of this court at Lee County Courthouse, 1700 Monroe Street, Fort Myers, 33901, either before service on Petitioner's attorney or immediately thereafter; otherwise a default will be entered against you for the relief demanded in the petition.
 WARNING: Rule 12.285, Florida Family Law Rules of Procedure, requires certain automatic disclosure of documents and information. Failure to comply can result in sanctions, including dismissal or striking of pleadings.
 DATED this 30th day of August, 2024.
 Kevin C. Karnes
 CLERK OF THE CIRCUIT COURT (SEAL) By: E. Bakelman Deputy Clerk
 Michele Belmont,
 Belmont Law Group,
 Petitioner's attorney,
 8270 College Parkway, #201,
 Fort Myers, FL 33919
 September 6, 13, 20, 27, 2024
 24-03725L

FOURTH INSERTION
NOTICE OF ACTION FOR This is an action for Temporary Custody IN THE CIRCUIT COURT OF THE 20th JUDICIAL CIRCUIT, IN AND FOR LEE COUNTY, FLORIDA
Case No.: 24-DR-005610
Rosalyn Estevez Companioni, Petitioner and Jeffery Hay, Respondent.
 TO: Jeffery Hay
 Unknown
 YOU ARE NOTIFIED that an action for Petition for Concurrent Custody has been filed against you and that you are required to serve a copy of your written defenses, if any, to it on Yelenis Maria Estevez, whose address is 1710 Park Meadow Drive, Unit 3, Fort Myers FL 33907, on or before October 8, 2024, and file the original with the clerk of this court at 1700 MONROE STREET, FORT MYERS, FL 33901, before service on Petitioner or immediately thereafter. If you fail to do so, a default may be entered against you for the relief demanded in the petition.
 Copies of all court documents in this case, including orders, are available at the Clerk of the Circuit Court's office. You may review these documents upon request.
 You must keep the Clerk of the Circuit Court's office notified of your current address. (You may file Designation of Current Mailing and E-Mail Address, Florida Supreme Court Approved Family Law Form 12.915.) Future papers in this lawsuit will be mailed or e-mailed to the addresses on record at the clerk's office.
 WARNING: Rule 12.285, Florida Family Law Rules of Procedure, requires certain automatic disclosure of documents and information. Failure to comply can result in sanctions, including dismissal or striking of pleadings.
 Dated: 08/29/2024.
 Kevin C. Karnes
 CLERK OF THE CIRCUIT COURT (SEAL) By: E. Bakelman Deputy Clerk
 September 6, 13, 20, 27, 2024
 24-03717L

--- TAX DEEDS ---

FOURTH INSERTION
NOTICE OF APPLICATION
FOR TAX DEED
Section 197.512 F.S.

Tax Deed #:2024001021
NOTICE IS HEREBY GIVEN that Savvy FL LLC First Horizon Collateral Assignee the holder of the following certificate(s) has filed said certificate(s) for a tax deed to be issued thereon. The certificate number(s), year(s) of issuance, the description of the property and the name(s) in which it was assessed are as follows:

Certificate Number: 26-56 Year of Issuance 2022 Description of Property CAPE CORAL UNIT 55 BLK.3980 PB 19 PG 98 LOTS 27 + 28 Strap Number 08-44-23-C4-03980.0270
Names in which assessed:
DAISY NIETO, FERNANDO NIETO
All of said property being in the County of Lee, State of Florida. Unless such certificate(s) shall be redeemed according to the law the property described in such certificate(s) will be sold to the highest bidder online at www.lee.realtaxdeed.com on 10/29/2024 at 10:00 am, by Kevin C. Karnes, Lee County Clerk of the Circuit Court & Comptroller.

September 6, 13, 20, 27, 2024
24-03674L

FOURTH INSERTION
NOTICE OF APPLICATION
FOR TAX DEED
Section 197.512 F.S.

Tax Deed #:2024000837
NOTICE IS HEREBY GIVEN that Savvy FL LLC First Horizon Collateral Assignee the holder of the following certificate(s) has filed said certificate(s) for a tax deed to be issued thereon. The certificate number(s), year(s) of issuance, the description of the property and the name(s) in which it was assessed are as follows:

Certificate Number: 27-52 Year of Issuance 2022 Description of Property CAPE CORAL UNIT 51 BLK 3734 PB 19 PG 7 LOTS 20 THRU 22 Strap Number 09-44-23-C4-03734.0200
Names in which assessed:
QUALITY CONTRACTORS OF AMERICA LLC, QUALITY CONTRACTORS OF AMERICA, LLC
All of said property being in the County of Lee, State of Florida. Unless such certificate(s) shall be redeemed according to the law the property described in such certificate(s) will be sold to the highest bidder online at www.lee.realtaxdeed.com on 10/29/2024 at 10:00 am, by Kevin C. Karnes, Lee County Clerk of the Circuit Court & Comptroller.

September 6, 13, 20, 27, 2024
24-03677L

FOURTH INSERTION
NOTICE OF APPLICATION
FOR TAX DEED
Section 197.512 F.S.

Tax Deed #:2024000760
NOTICE IS HEREBY GIVEN that Mikon Financial Services Inc and Ocean Bank the holder of the following certificate(s) has filed said certificate(s) for a tax deed to be issued thereon. The certificate number(s), year(s) of issuance, the description of the property and the name(s) in which it was assessed are as follows:

Certificate Number: 60-33 Year of Issuance 2022 Description of Property CAPE CORAL UNIT 46 BLK 3592 PB 17 PG 124 LOTS 10 + 11 Strap Number 07-44-24-C4-03592.0100
Names in which assessed:
MICHAEL H MARCINKIEWICZ, MICHAEL MARCINKIEWICZ
All of said property being in the County of Lee, State of Florida. Unless such certificate(s) shall be redeemed according to the law the property described in such certificate(s) will be sold to the highest bidder online at www.lee.realtaxdeed.com on 10/29/2024 at 10:00 am, by Kevin C. Karnes, Lee County Clerk of the Circuit Court & Comptroller.

September 6, 13, 20, 27, 2024
24-03692L

FOURTH INSERTION
NOTICE OF APPLICATION
FOR TAX DEED
Section 197.512 F.S.

Tax Deed #:2024000761
NOTICE IS HEREBY GIVEN that Mikon Financial Services Inc and Ocean Bank the holder of the following certificate(s) has filed said certificate(s) for a tax deed to be issued thereon. The certificate number(s), year(s) of issuance, the description of the property and the name(s) in which it was assessed are as follows:

Certificate Number: 26-71 Year of Issuance 2022 Description of Property CAPE CORAL UNIT 55 BLK 4009 PB 19 PG 97 LOTS 63 + 64 Strap Number 08-44-23-C4-04009.0630
Names in which assessed:
MARIA ALICIA ALEXANDER PAZ
All of said property being in the County of Lee, State of Florida. Unless such certificate(s) shall be redeemed according to the law the property described in such certificate(s) will be sold to the highest bidder online at www.lee.realtaxdeed.com on 10/29/2024 at 10:00 am, by Kevin C. Karnes, Lee County Clerk of the Circuit Court & Comptroller.

September 6, 13, 20, 27, 2024
24-03675L

FOURTH INSERTION
NOTICE OF APPLICATION
FOR TAX DEED
Section 197.512 F.S.

Tax Deed #:2024000725
NOTICE IS HEREBY GIVEN that Mikon Financial Services Inc and Ocean Bank the holder of the following certificate(s) has filed said certificate(s) for a tax deed to be issued thereon. The certificate number(s), year(s) of issuance, the description of the property and the name(s) in which it was assessed are as follows:

Certificate Number: 22-406 Year of Issuance 2022 Description of Property LEHIGH ACRES UNIT 6 BLK 30 PB 18 PG 144 LOT 4 Strap Number 36-45-27-06-00030.0040
Names in which assessed:
INFINITE WEALTH INVESTMENTS LLC, INFINITE WEALTH INVESTMENTS, LLC
All of said property being in the County of Lee, State of Florida. Unless such certificate(s) shall be redeemed according to the law the property described in such certificate(s) will be sold to the highest bidder online at www.lee.realtaxdeed.com on 10/29/2024 at 10:00 am, by Kevin C. Karnes, Lee County Clerk of the Circuit Court & Comptroller.

September 6, 13, 20, 27, 2024
24-03670L

FOURTH INSERTION
NOTICE OF APPLICATION
FOR TAX DEED
Section 197.512 F.S.

Tax Deed #:2024000733
NOTICE IS HEREBY GIVEN that Mikon Financial Services Inc and Ocean Bank the holder of the following certificate(s) has filed said certificate(s) for a tax deed to be issued thereon. The certificate number(s), year(s) of issuance, the description of the property and the name(s) in which it was assessed are as follows:

Certificate Number: 83-63 Year of Issuance 2022 Description of Property WOODSIDE BLK 6 PB 1 PG 58 LOTS 11 + 12 Strap Number 08-44-25-P4-01906.0110
Names in which assessed:
BETTIE JACKSON, BETTY FLEMING, LEE E FLEMING JR, LEE E FLEMING JR
All of said property being in the County of Lee, State of Florida. Unless such certificate(s) shall be redeemed according to the law the property described in such certificate(s) will be sold to the highest bidder online at www.lee.realtaxdeed.com on 10/29/2024 at 10:00 am, by Kevin C. Karnes, Lee County Clerk of the Circuit Court & Comptroller.

September 6, 13, 20, 27, 2024
24-03700L

FOURTH INSERTION
NOTICE OF APPLICATION
FOR TAX DEED
Section 197.512 F.S.

Tax Deed #:2024000735
NOTICE IS HEREBY GIVEN that Mikon Financial Services Inc and Ocean Bank the holder of the following certificate(s) has filed said certificate(s) for a tax deed to be issued thereon. The certificate number(s), year(s) of issuance, the description of the property and the name(s) in which it was assessed are as follows:

Certificate Number: 27-20 Year of Issuance 2022 Description of Property CAPE CORAL UNIT 51 BLK 3775 PB 19 PG 15 LOTS 59 THRU 61 Strap Number 09-44-23-C2-03775.0590
Names in which assessed:
MARISSA RICARDO, THIAGO PLATZ
All of said property being in the County of Lee, State of Florida. Unless such certificate(s) shall be redeemed according to the law the property described in such certificate(s) will be sold to the highest bidder online at www.lee.realtaxdeed.com on 10/29/2024 at 10:00 am, by Kevin C. Karnes, Lee County Clerk of the Circuit Court & Comptroller.

September 6, 13, 20, 27, 2024
24-03676L

FOURTH INSERTION
NOTICE OF APPLICATION
FOR TAX DEED
Section 197.512 F.S.

Tax Deed #:2024000704
NOTICE IS HEREBY GIVEN that Mikon Financial Services Inc and Ocean Bank the holder of the following certificate(s) has filed said certificate(s) for a tax deed to be issued thereon. The certificate number(s), year(s) of issuance, the description of the property and the name(s) in which it was assessed are as follows:

Certificate Number: 11-976 Year of Issuance 2022 Description of Property BUCKINGHAM PK RE BLK B U-5 BLK 29 PB 27 PG 193 LOT 3 Strap Number 16-44-26-08-00029.0030
Names in which assessed:
JAMES M MOSHER, MICHAEL B MOSHER, THERESA M WILLIAMSON, WILLIAM J MOSHER, WILLIAM MOSHER
All of said property being in the County of Lee, State of Florida. Unless such certificate(s) shall be redeemed according to the law the property described in such certificate(s) will be sold to the highest bidder online at www.lee.realtaxdeed.com on 10/29/2024 at 10:00 am, by Kevin C. Karnes, Lee County Clerk of the Circuit Court & Comptroller.

September 6, 13, 20, 27, 2024
24-03649L

FOURTH INSERTION
NOTICE OF APPLICATION
FOR TAX DEED
Section 197.512 F.S.

Tax Deed #:2024000695
NOTICE IS HEREBY GIVEN that TLOA OF FLORIDA LLC FOR SECURED PARTY the holder of the following certificate(s) has filed said certificate(s) for a tax deed to be issued thereon. The certificate number(s), year(s) of issuance, the description of the property and the name(s) in which it was assessed are as follows:

Certificate Number: 75-01 Year of Issuance 2022 Description of Property GARDENS AT BEACHWALK DESC IN OR 4224 PG 3575 PH 2 BLDG 6 UNIT 6-2-112 Strap Number 31-45-24-55-00006.0112
Names in which assessed:
ANGELA R TILLISON-ISHAM
All of said property being in the County of Lee, State of Florida. Unless such certificate(s) shall be redeemed according to the law the property described in such certificate(s) will be sold to the highest bidder online at www.lee.realtaxdeed.com on 10/29/2024 at 10:00 am, by Kevin C. Karnes, Lee County Clerk of the Circuit Court & Comptroller.

September 6, 13, 20, 27, 2024
24-03694L

FOURTH INSERTION
NOTICE OF APPLICATION
FOR TAX DEED
Section 197.512 F.S.

Tax Deed #:2024000752
NOTICE IS HEREBY GIVEN that Mikon Financial Services Inc and Ocean Bank the holder of the following certificate(s) has filed said certificate(s) for a tax deed to be issued thereon. The certificate number(s), year(s) of issuance, the description of the property and the name(s) in which it was assessed are as follows:

Certificate Number: 57-80 Year of Issuance 2022 Description of Property COUNTRY PINES CONDO PH 3 OR 1639 PG 2179 UNIT 1108 Strap Number 04-44-24-05-00000.1108
Names in which assessed:
JOHN H GERBER, TARA B GERBER
All of said property being in the County of Lee, State of Florida. Unless such certificate(s) shall be redeemed according to the law the property described in such certificate(s) will be sold to the highest bidder online at www.lee.realtaxdeed.com on 10/29/2024 at 10:00 am, by Kevin C. Karnes, Lee County Clerk of the Circuit Court & Comptroller.

September 6, 13, 20, 27, 2024
24-03687L

FOURTH INSERTION
NOTICE OF APPLICATION
FOR TAX DEED
Section 197.512 F.S.

Tax Deed #:2024000739
NOTICE IS HEREBY GIVEN that Mikon Financial Services Inc and Ocean Bank the holder of the following certificate(s) has filed said certificate(s) for a tax deed to be issued thereon. The certificate number(s), year(s) of issuance, the description of the property and the name(s) in which it was assessed are as follows:

Certificate Number: 42-49 Year of Issuance 2022 Description of Property FRAC SEC NW COR ACRETION TO GOVT LOT 4 SEC 22 TWP 45 RGE 23. Strap Number 27-45-23-C2-00002.0000
Names in which assessed:
A DONALD BASS REVOCABLE TRUST DATED THE 8TH DAY OF MARCH 1990, A DONALD BASS TRUST
All of said property being in the County of Lee, State of Florida. Unless such certificate(s) shall be redeemed according to the law the property described in such certificate(s) will be sold to the highest bidder online at www.lee.realtaxdeed.com on 10/29/2024 at 10:00 am, by Kevin C. Karnes, Lee County Clerk of the Circuit Court & Comptroller.

September 6, 13, 20, 27, 2024
24-03680L

FOURTH INSERTION
NOTICE OF APPLICATION
FOR TAX DEED
Section 197.512 F.S.

Tax Deed #:2024000756
NOTICE IS HEREBY GIVEN that Mikon Financial Services Inc and Ocean Bank the holder of the following certificate(s) has filed said certificate(s) for a tax deed to be issued thereon. The certificate number(s), year(s) of issuance, the description of the property and the name(s) in which it was assessed are as follows:

Certificate Number: 78-4 Year of Issuance 2022 Description of Property CAPE CORAL UNIT 96 BLK 6090 PB 25 PG 96 LOTS 36 + 37 Strap Number 07-43-23-C1-06090.0360
Names in which assessed:
ORVILLE JOHNSON, PRISCILLA JOHNSON
All of said property being in the County of Lee, State of Florida. Unless such certificate(s) shall be redeemed according to the law the property described in such certificate(s) will be sold to the highest bidder online at www.lee.realtaxdeed.com on 10/29/2024 at 10:00 am, by Kevin C. Karnes, Lee County Clerk of the Circuit Court & Comptroller.

September 6, 13, 20, 27, 2024
24-03697L

FOURTH INSERTION
NOTICE OF APPLICATION
FOR TAX DEED
Section 197.512 F.S.

Tax Deed #:2024000731
NOTICE IS HEREBY GIVEN that Mikon Financial Services Inc and Ocean Bank the holder of the following certificate(s) has filed said certificate(s) for a tax deed to be issued thereon. The certificate number(s), year(s) of issuance, the description of the property and the name(s) in which it was assessed are as follows:

Certificate Number: 58-79 Year of Issuance 2022 Description of Property CAPE CORAL UNIT 31 BLK 2063 PB 14 PG 162 LOTS 13 + 14 Strap Number 06-44-24-C2-02063.0130
Names in which assessed:
BERMUDEZ CONSTRUCTORES E INMOBILIARIA SAS
All of said property being in the County of Lee, State of Florida. Unless such certificate(s) shall be redeemed according to the law the property described in such certificate(s) will be sold to the highest bidder online at www.lee.realtaxdeed.com on 10/29/2024 at 10:00 am, by Kevin C. Karnes, Lee County Clerk of the Circuit Court & Comptroller.

September 6, 13, 20, 27, 2024
24-03689L

FOURTH INSERTION
NOTICE OF APPLICATION
FOR TAX DEED
Section 197.512 F.S.

Tax Deed #:2024000921
NOTICE IS HEREBY GIVEN that Savvy FL LLC First Horizon Collateral Assignee the holder of the following certificate(s) has filed said certificate(s) for a tax deed to be issued thereon. The certificate number(s), year(s) of issuance, the description of the property and the name(s) in which it was assessed are as follows:

Certificate Number: 14-039 Year of Issuance 2022 Description of Property LEHIGH ACRES UNIT 11 BLK.104 PB 15 PG 95 LOTS 4 + 5 LESS SUBSURFACE RIGHTS ASSESSED UNDER 03-45-26-99-11104.0040 AS DESC IN OR 4516 PG 2118 Strap Number 03-45-26-11-00104.0040
Names in which assessed:
GEORGE BOGICH
All of said property being in the County of Lee, State of Florida. Unless such certificate(s) shall be redeemed according to the law the property described in such certificate(s) will be sold to the highest bidder online at www.lee.realtaxdeed.com on 10/29/2024 at 10:00 am, by Kevin C. Karnes, Lee County Clerk of the Circuit Court & Comptroller.

September 6, 13, 20, 27, 2024
24-03653L

FOURTH INSERTION
NOTICE OF APPLICATION
FOR TAX DEED
Section 197.512 F.S.

Tax Deed #:2024000758
NOTICE IS HEREBY GIVEN that Mikon Financial Services Inc and Ocean Bank the holder of the following certificate(s) has filed said certificate(s) for a tax deed to be issued thereon. The certificate number(s), year(s) of issuance, the description of the property and the name(s) in which it was assessed are as follows:

Certificate Number: 83-1 Year of Issuance 2022 Description of Property CAPE CORAL UNIT 97 BLK 6100 PB 25 PG 91 LOTS 44 + 45 Strap Number 07-43-23-C4-06100.0440
Names in which assessed:
DULCE DE PAULA, DULCE DEPAULA
All of said property being in the County of Lee, State of Florida. Unless such certificate(s) shall be redeemed according to the law the property described in such certificate(s) will be sold to the highest bidder online at www.lee.realtaxdeed.com on 10/29/2024 at 10:00 am, by Kevin C. Karnes, Lee County Clerk of the Circuit Court & Comptroller.

September 6, 13, 20, 27, 2024
24-03699L

FOURTH INSERTION
NOTICE OF APPLICATION
FOR TAX DEED
Section 197.512 F.S.

Tax Deed #:2024000746
NOTICE IS HEREBY GIVEN that Mikon Financial Services Inc and Ocean Bank the holder of the following certificate(s) has filed said certificate(s) for a tax deed to be issued thereon. The certificate number(s), year(s) of issuance, the description of the property and the name(s) in which it was assessed are as follows:

Certificate Number: 58-82 Year of Issuance 2022 Description of Property CAPE CORAL UNIT 31 BLK 2064 PB 14 PG 165 LOTS 8 + 9 Strap Number 06-44-24-C2-02064.0080
Names in which assessed:
JACK PINNOCK, MAZIE PINNOCK
All of said property being in the County of Lee, State of Florida. Unless such certificate(s) shall be redeemed according to the law the property described in such certificate(s) will be sold to the highest bidder online at www.lee.realtaxdeed.com on 10/29/2024 at 10:00 am, by Kevin C. Karnes, Lee County Clerk of the Circuit Court & Comptroller.

September 6, 13, 20, 27, 2024
24-03690L

FOURTH INSERTION
NOTICE OF APPLICATION
FOR TAX DEED
Section 197.512 F.S.

Tax Deed #:2024001014
NOTICE IS HEREBY GIVEN that Savvy FL LLC First Horizon Collateral Assignee the holder of the following certificate(s) has filed said certificate(s) for a tax deed to be issued thereon. The certificate number(s), year(s) of issuance, the description of the property and the name(s) in which it was assessed are as follows:

Certificate Number: 58-33 Year of Issuance 2022 Description of Property CAPE CORAL UNIT 47 PT 2 BLK 3511 PB 23 PG 124 LOTS 61 + 62 Strap Number 05-44-24-C2-03511.0610
Names in which assessed:
BENJAMIN DIVINAGRACIA, DANIEL DIVINAGRACIA, GREGORIO DIVINAGRACIA, ISMAEL DIVINAGRACIA, JOSE DIVINAGRACIA, MANUEL DIVINAGRACIA, MONICA DIVINAGRACIA, SERGIO DIVINAGRACIA
All of said property being in the County of Lee, State of Florida. Unless such certificate(s) shall be redeemed according to the law the property described in such certificate(s) will be sold to the highest bidder online at www.lee.realtaxdeed.com on 10/29/2024 at 10:00 am, by Kevin C. Karnes, Lee County Clerk of the Circuit Court & Comptroller.

September 6, 13, 20, 27, 2024
24-03688L

FOURTH INSERTION
NOTICE OF APPLICATION
FOR TAX DEED
Section 197.512 F.S.

Tax Deed #:2024000681
NOTICE IS HEREBY GIVEN that TLOA OF FLORIDA LLC FOR SECURED PARTY the holder of the following certificate(s) has filed said certificate(s) for a tax deed to be issued thereon. The certificate number(s), year(s) of issuance, the description of the property and the name(s) in which it was assessed are as follows:

Certificate Number: 82-52 Year of Issuance 2022 Description of Property IDLE TIME S/D BLK B PB 28 PG 41 SLY 45 FT LT 3 + NLY 25 FT LT 4 Strap Number 08-44-25-P1-0010B.0030
Names in which assessed:
JAMES THOMAS MOORE
All of said property being in the County of Lee, State of Florida. Unless such certificate(s) shall be redeemed according to the law the property described in such certificate(s) will be sold to the highest bidder online at www.lee.realtaxdeed.com on 10/29/2024 at 10:00 am, by Kevin C. Karnes, Lee County Clerk of the Circuit Court & Comptroller.

September 6, 13, 20, 27, 2024
24-03698L

HOW TO PUBLISH YOUR LEGAL NOTICE IN THE BUSINESS OBSERVER

CALL 941-906-9386
and select the appropriate County name from the menu option or e-mail legal@businessobserverfl.com

Business Observer

THIRD INSERTION

NOTICE OF ASSIGNMENT FOR THE BENEFIT OF CREDITORS
IN THE CIRCUIT COURT OF THE 20TH JUDICIAL CIRCUIT IN AND FOR LEE COUNTY, FLORIDA CIVIL DIVISION
Case No. 24-CP-006082

In Re: BEATTIE DEVELOPMENT CORPORATION, Assignor, LARRY S. HYMAN, Assignee.
TO: ALL CREDITORS AND OTHER INTERESTED PARTIES:

1. PLEASE TAKE NOTICE that on

or about September 3, 2024, a Petition was filed commencing an Assignment for the Benefit of Creditors, pursuant to Chapter 727, Fla. Stat., made by BEATTIE DEVELOPMENT CORPORATION, Assignor, with its principal place of business at 857 SE 47th Street, Cape Coral, FL 33904, to Larry S. Hyman, Assignee, whose address is PO Box 18625, Tampa, FL 33679. The Petition was filed in the Circuit Court of Lee County.

2. YOU ARE HEREBY FURTHER NOTICED that pursuant to Fla. Stat. §727.105, no proceeding may be commenced against the Assignee except as

provided in Chapter 727, and excepting the case of the secured creditor enforcing its rights in collateral under Chapter 679, there shall be no levy, execution, attachment or the like, in connection with any judgment or claim against assets of the Estate, other than real property, in the possession, custody or control of the Assignee.

3. YOU ARE HEREBY FURTHER NOTIFIED that in order to receive any dividend in this proceeding, you must file a Proof of Claim with the Assignee on or before January 2, 2025.
Sept. 13, 20, 27; Oct. 4, 2024

24-03848L

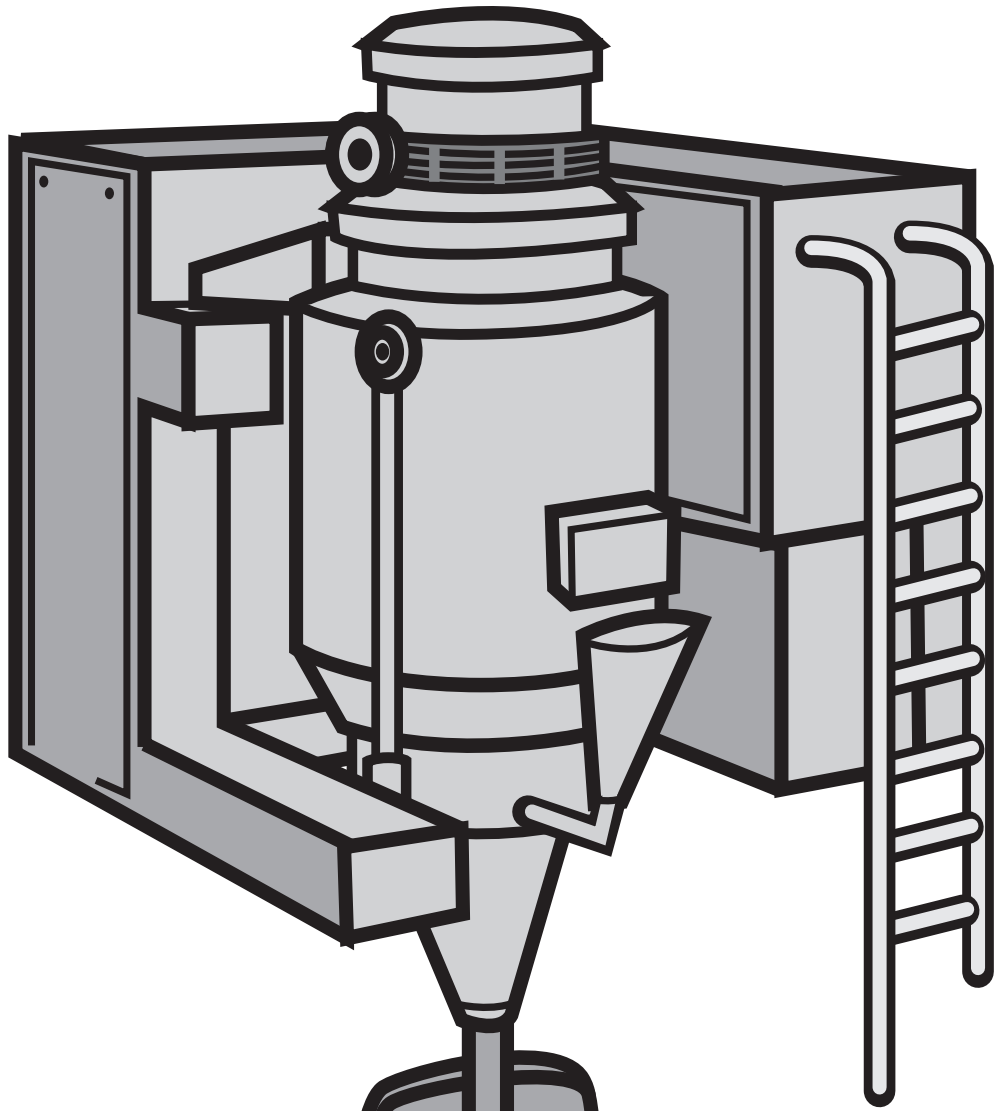

TOM SMITH AND HIS INCREDIBLE BREAD MACHINE

By R.W. Grant

Illustrations by Austin McKinley

This is the legend of a man whose name
Was a household word: a man whose fame
Burst on the world like an atom bomb.
Smith was his last name; first name: Tom.

The argument goes on today.
"He was a villain," some will say.
"No! A hero!" others declare.
Or was he both? Well, I despair;
The fight will last 'til kingdom come;
Was Smith a hero? Or was Smith a bum?
So, listen to the story and it's up to you
To decide for yourself as to which is true!

Now, Smith, an inventor, had specialized
In toys. So people were surprised
When they found that he instead
Of making toys, was baking bread!
The news was flashed by CBS
Of his incredible success.
Then NBC jumped in in force,
Followed by the Times, of course.
The reason for their rapt attention,
The nature of his new invention,
The way to make bread he'd conceived
Cost less than people could believe!
And not just make it! This device
Could in addition wrap and slice!
The price per loaf, one loaf or many:
The miniscule sum of under one penny!

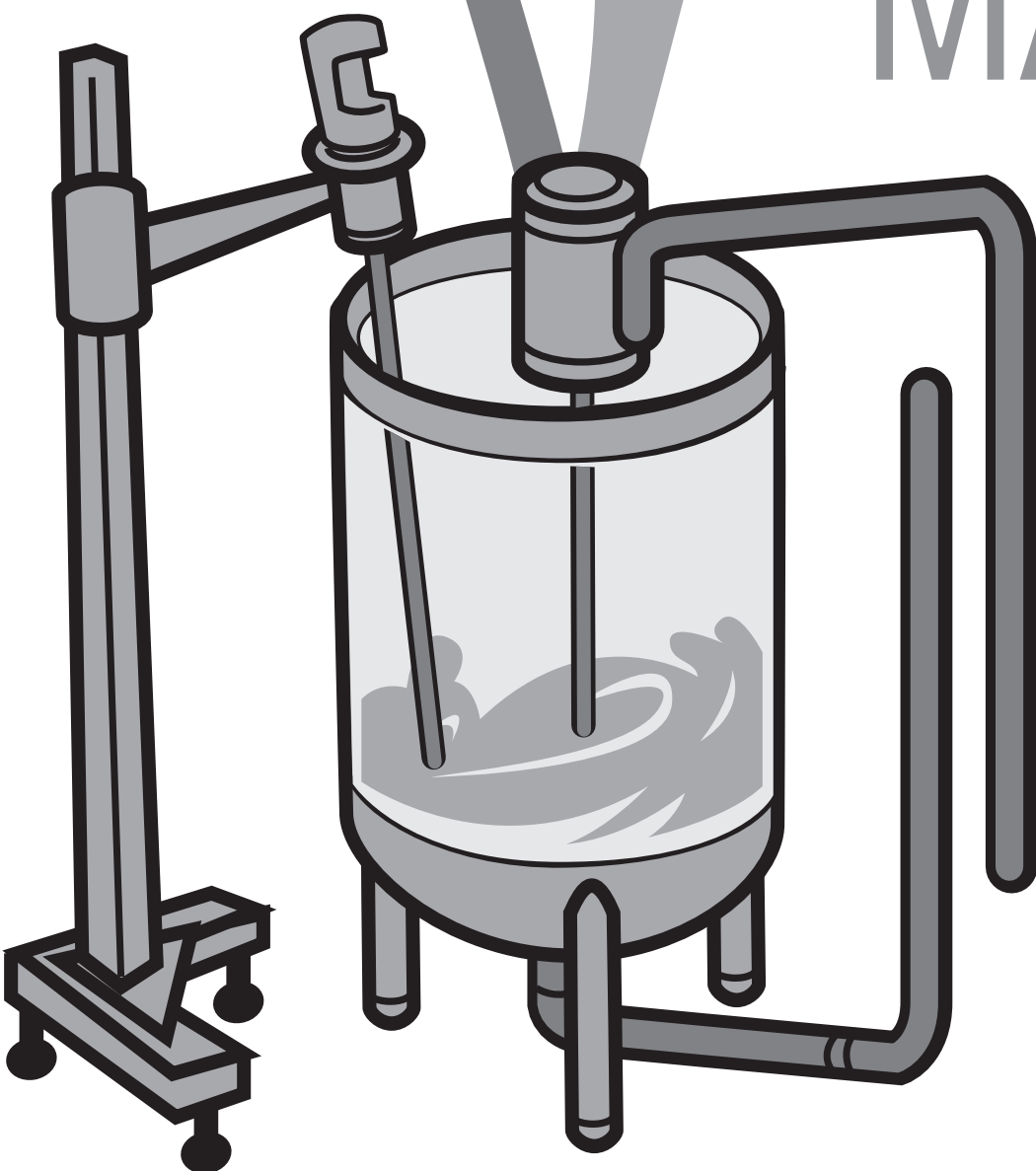

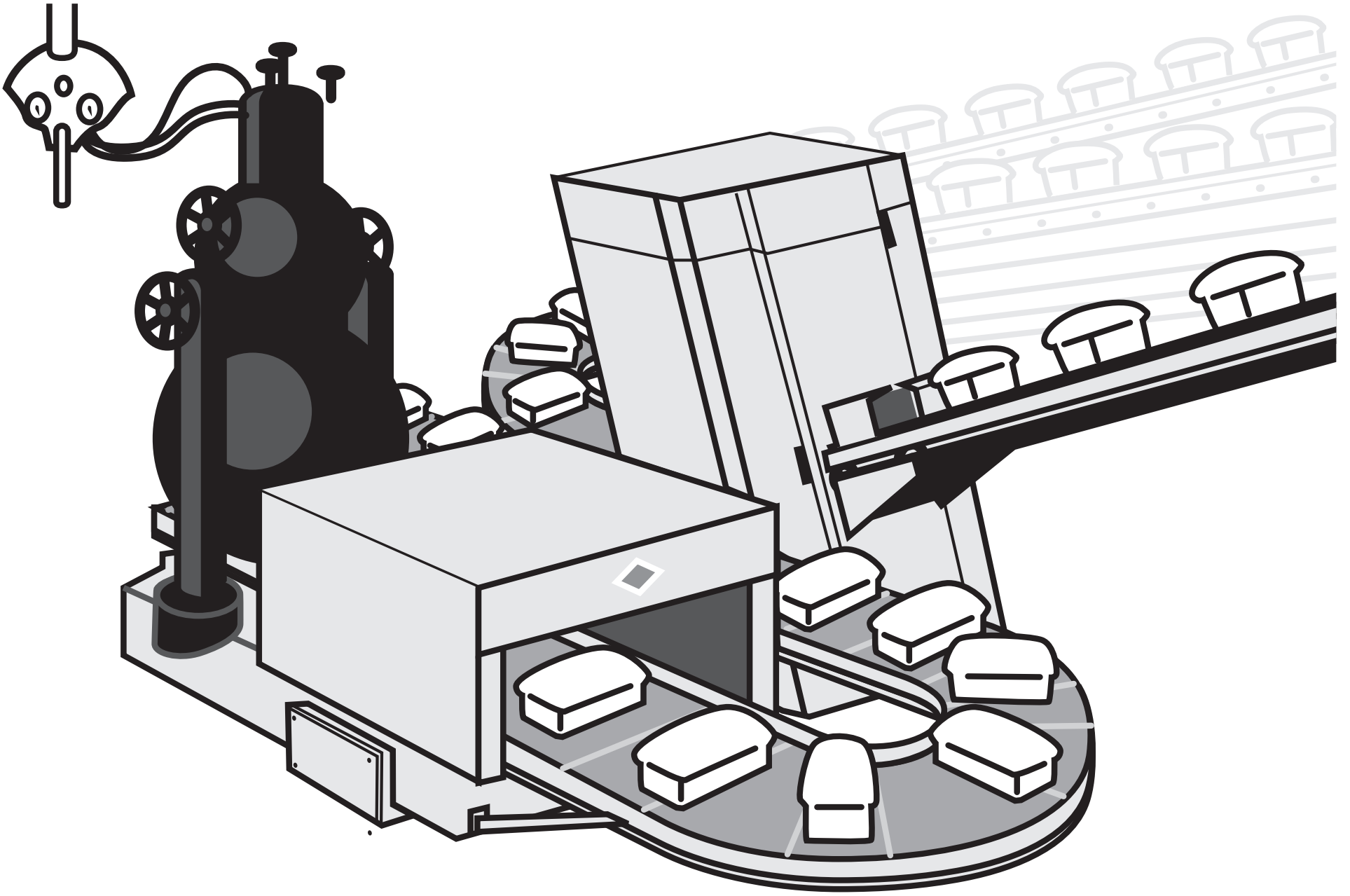

Can you imagine what this meant?
Can you comprehend the consequent?
The first time yet the world well fed!
And all because of Tom Smith's bread!

Not the last to see the repercussions
Were the Red Chinese, and, of course, the
Russians,
For Capitalist bread in such array

Threw the whole red block into black dis-
may!
Nonetheless, the world soon found
That bread was plentiful the world
around.
Thanks to Smith and all that bread,
A grateful world was at last well fed!

But isn't it a wondrous thing
How quickly fame is flown?
Smith, the hero of today
Tomorrow, scarcely known!
Yes, the fickle years passed by.
Smith was a billionaire.

But Smith himself was now forgot,
Though bread was everywhere.
People, asked from where it came,
Would very seldom know.

They would simply eat and ask,
'Was not it always so?'

However, Smith cared not a bit,
For millions ate his bread,
And "Everything is fine," thought he.
'I'm rich and they are fed!'

Everything was fine, he thought?
He reckoned not with fate.
Note the sequence of events
Starting on the date
On which inflation took its toll,
And to a slight extent,
The price on every loaf increased:
It went to one full cent!

A sharp reaction quickly came.
People were concerned.
White House aide expressed dismay.
Then the nation learned
That Russia lodged a sharp protest.
India did the same.
"Exploitation of the Poor!"
Yet, who was there to blame?

And though the clamor ebbed and flowed,
All that Tom would say
Was that it was but foolish talk.
Which soon would die away.
And it appeared that he was right.
Though on and on it ran,
The argument went 'round and 'round
But stopped where it began.

There it stopped, and people cried,
"For heaven's sake, we can't decide!
It's relative! Beyond dispute,
There's no such thing as 'absolute'!
And though we try with all our might,
Since nothing's ever black or white,
All that we can finally say is
'Everything one shade of grey is!'
So people cried out, "Give us light!
We can't tell what's wrong from right!"

To comprehend confusion,
We seek wisdom at its source.
To whom, then did the people turn?
The Intellectuals, of course!

And what could be a better time
For them to take the lead,
Than at their International Conference
On Inhumanity and Greed.
For at this weighty conference,
Once each year we face
The moral conscience of the world—
Concentrated in one place.

At that mighty conference were
A thousand, more or less,
Of intellectuals and bureaucrats,
And those who write the press.
And from Yale and Harvard
The professors; all aware
The fate of Smith would now be known.
Excitement filled the air!

"The time has come," the chairman said
"To speak of many things:
Of duty, bread and selfishness,
And the evil that it brings.
For, speaking thus we can amend
That irony of fate
That gives to unenlightened minds
The power to create.



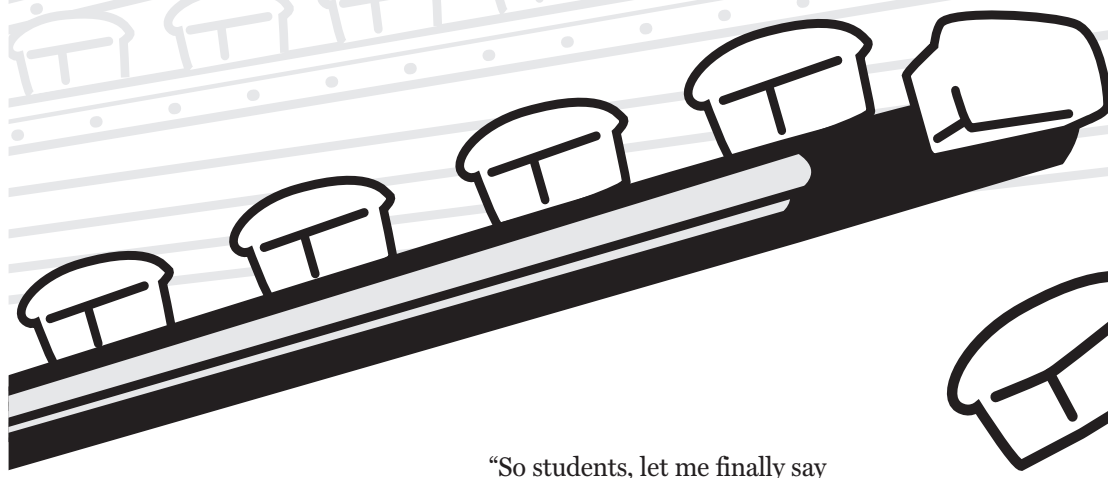

“Since reason tells us that it can’t,
Therefore let us start
Not by thinking with the mind,
But only with the heart!
Since we believe in people, then,”
At last the chairman said,
“We must meet our obligation
To see that they are fed!”

And so it went, one by one,
Denouncing private greed;
Denouncing those who’d profit thus
From other people’s need!

Then, suddenly each breath was held,
For there was none more wise
Than the nation’s foremost Pundit
Who now rose to summarize:

“My friends,” he said, (they all
exhaled)
“We see in these events
The flouting of the Higher Law—
And its consequence.
We must again remind ourselves
Just why mankind is cursed:
Because we fail to realize
Society comes first!”

“Smith placed himself above the
group
To profit from his brothers.
He failed to see the Greater Good,
Is Service, friends, to Others!”

With boldness and with vision,
then,
They ratified the motion
To dedicate to all mankind
Smith’s bread—and their devotion!

The conference finally ended.
It had been a huge success.
The intellectuals had spoken.
Now others did the rest.

The professors joined in all the
fuss,
And one was heard to lecture thus:
(For clarity, he spoke in terms
Of Mother Nature, birds and worms):

“That early birds should get the worm
Is clearly quite unfair.
Wouldn’t it much nicer be
If all of them would share?
But selfishness and private greed

Seem part of nature’s plan,
Which Mother Nature has decreed
For bird. But also Man?
The system which I question now,
As you are well aware,
(I’m sure you’ve heard the term
before
Is Business, Laissez-Faire!

“So students, let me finally say
That we must find a nobler way.
So, let us fix the race that all
May finish side-by-side;
The playing field forever flat,
The score forever tied.
To achieve this end, of course,
We turn to government—and force.
So, if we have to bring Smith do
As indeed we should,
I’m sure you will agree with me,
It’s for the Greater Good!”

Comments in the nation’s press
Now scorned Smith and his plunder:
“What right had he to get so rich
On other people’s hunger?”
A prize cartoon depicted Smith
With fat and drooping jowls
Snatching bread from hungry babes,
Indifferent to their howls.

One night, a TV star cried out,
“Forgive me if I stumble,
But I don’t think, I kid you not,
That Smith is very humble!”
Growing bolder, he leaped up,

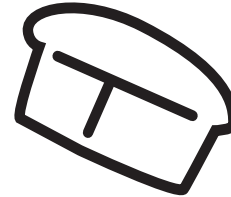
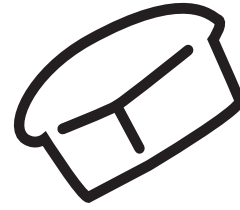

(Silencing the cheers)
“Humility!” he cried to all—
And then collapsed in tears!

The clamor rises all about;
Now hear the politician shout:
“What’s Smith done, so rich to be?
Why should Smith have more than thee?
So, down with Smith and all his greed;
I’ll protect your right to need!”

Then Tom found to his dismay
That certain businessmen would say,
“The people now should realize
It’s time to cut Smith down to size,
For he’s betrayed his public trust
(And taken all that bread from us!)”

Well, since the Public does come first,
It could not be denied
That in matters such as this,
The public must decide.
So, SEC became concerned,
And told the press what it had learned:
“It’s obvious that he’s guilty
—Of what we’re not aware—
Though actually and factually
We’re sure there’s something there!”

And Antitrust now took a hand.
Of course it was appalled
At what it found was going on.
The “bread trust” it was called.

“Smith has too much crust,”
they said. “A deplorable condition
That Robber Barons profit thus
From cutthroat competition!”

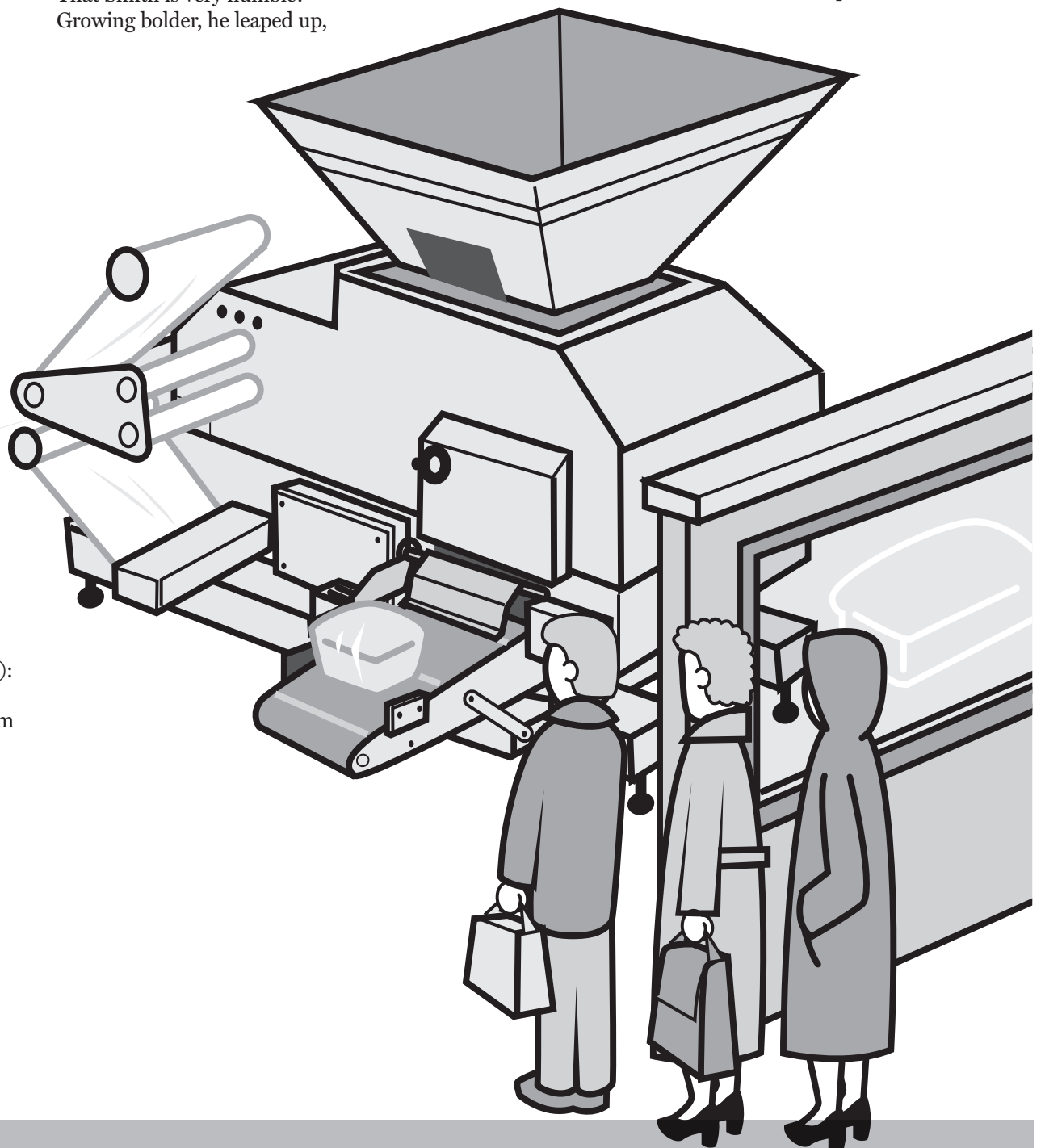

WELL!

This was getting serious!
So Smith felt that he must
Have a friendly interview
With SEC and "Trust."
So, hat in hand, he went to them.
They'd surely been misled;
No rule of law had he defied.
But then their lawyer said:

"The rule of law, in complex times,
Has proved itself deficient.
We much prefer the rule of men.
It's vastly more efficient.

"So, nutshell-wise, the way it is,
The law is what we say it is!

"So, let me state the present rules,"
The lawyer then went on,
"These very simple guidelines
You can rely upon:
You're gouging on your prices
If you charge more than the rest.
But it's unfair competition
If you think you can charge less!
"A second point that we would make,
To help avoid confusion:
Don't try to charge the same amount,
For that would be collusion!"

"You must compete—but not too much.
For if you do, you see,
Then the market would be yours—
And that's monopoly!
Oh, don't dare monopolize!
We'd raise an awful fuss,
For that's the greatest crime of all!
(Unless it's done by us!)"

"I think I understand," said Tom.
"And yet, before I go,
How does one get a job like yours?
I'd really like to know!"

The lawyer rose then with a smile;
"I'm glad you asked," said he.
"I'll tell you how I got my start
And how it came to be."

(His secretaries gathered 'round
As their boss did thus expound.)

*"When I was a lad going off to school,
I was always guided by this golden rule:
Let others take the lead in things, for
heaven's sake,
So if things go wrong-why, then it's their
mistake!"*
(*So if things go wrong-why, then it's their
mistake!*)

*"Following this precept it came to pass
I became the president of my senior class.
Then on to college where my profs extolled
The very same theory from the very same
mold!"*
(*The very same theory from the very same
mold!*)

*"Let others take the chances, and I would
go along.
Then I would let them know where they all
went wrong!
So successful was my system that then
indeed,
I was voted most likely in my class to suc-
ceed!"*

*(He was voted most likely in his class to
succeed!)*

*"Then out into the world I went, along
with all the rest,
Where I put my golden rule to the ulti-
mate test.
I avoided all of commerce at whatever the
cost—
And because I never ventured, then I also
never lost!"*
(*And because he never ventured, then he
also never lost!*)

*"With this unblemished record then, I
quickly caught the eye
Of some influential people 'mongst the
powers on high.*

*And so these many years among the
mighty I have sat,
Having found my niche as a bureaucrat!"*
(*Having found his niche as a bureaucrat*)

*"To be a merchant prince has never been
my goal,
For I'm qualified to play a more impor-
tant role:
Since I've never failed in business, this of
course assures
That I'm qualified beyond dispute to now
run yours!"*
(*That he's qualified beyond dispute to now
run yours!*)

"Thanks; that clears it up," said Tom.

The lawyer said, "I'm glad!
We try to serve the public good.
We're really not so bad!"

"Now, in disposing of this case,
If you wish to know just how,
Go up to the seventh floor;
We're finalizing now!"

So, Tom went to the conference room
Up on the seventh floor.
He raised his hand, about to knock,
He raised it—but no more—
For what he overheard within
Kept him outside the door!
A sentence here, a sentence there—
Every other word—
He couldn't make it out (he hoped),
For this is what he heard:

"Mumble, mumble, let's not fumble!
Mumble, mumble, what's the charge?
Grumble, grumble, he's not humble?
Private greed? Or good of all?"

"Public Interest, Rah! Rah! Rah!
Business, Business, Bah! Bah! Bah!"

"Say, now this now we confess
That now this now is a mess!
Well now, what now do we guess?
Discharge? Which charge would be best?"

"How 'bout 'Greed and Selfishness'?
Oh, wouldn't that be fun?
It's vague enough to trip him up
No matter what he's done!"

"We don't produce or build a thing!
But before we're through,
We allow that now we'll show Smith how
We handle those who do!"

"We serve the public interest;
We make up our own laws;
Oh, golly gee, how selflessly
We serve the public cause!"

"For we're the ones who make the rules
At 'Trust and SEC,
So bye and bye we'll get that guy;
Now, what charge will it be?"

"Price too high? Or price too low?
Now, which charge will we make?
Well, we're not loath to charging both
When public good's at stake!"

"But can we go one better?
How 'bout monopoly?
No muss, no fuss, oh clever us!
Right-O! Let's charge all three!"

"But why stop here? We have one more!
Insider Trading! Number four!
We've not troubled to define
This crime in any way so,
This allows the courts to find
Him guilty 'cause we say so!"

So, that was the indictment.
Smith's trial soon began.
It was a cause célèbre
Which was followed' cross the land.
In his defense Tom only said,
"I'm rich, but all of you are fed!
Is that bargain so unjust
That I should now be punished thus?"

Tom fought it hard all the way.
But it didn't help him win.
The jury took but half an hour
To bring this verdict in:

"Guilty! Guilty! We agree!
He's guilty of this plunder!
He had no right to get so rich
On other people's hunger!"

"Five years in jail!" the judge then said.
"You're lucky it's not worse!
Robber Barons must be taught
Society Comes First!
As flies to wanton boys," he leered,
"Are we to men like these!
They exploit us for their sport!
Exploit us as they please!"

The sentence seemed a bit severe,
But mercy was extended.
In deference to his mother's pleas,
One year was suspended.
And what about the Bread Machine?
Tom Smith's little friend?
Broken up and sold for scrap.
Some win. Some lose. The end.

EPILOGUE

Now, bread is baked by government.
And as might be expected,
Everything is well controlled—
The public well protected.

True, loaves cost ten dollars each.
But our leaders do their best.
The selling price is half a cent.
Taxes pay the rest!

