

COLLIER COUNTY LEGAL NOTICES

--- PUBLIC SALES / ESTATE ---

FIRST INSERTION

NOTICE OF PUBLIC SALE OF PERSONAL PROPERTY

Please take notice SmartStop Self Storage located at 275 Goodlette Frank Road, Naples, FL 34102 intends to hold an auction of the goods stored in the following units to satisfy the lien of the owner. The sale will occur as an online auction via www.selfstorageauction.com on 01/23/2025 at 2:30pm. Contents include personal property along with the described belongings to those individuals listed below.

3219A Jonathan Russell bags, household items etc.
04006 Chazzaray Runyon furniture, household items, etc.
02100 Ronald Ray Caruso wall arts, bicycles, shelves, household items. Etc.

Purchases must be paid at the above referenced facility in order to complete the transaction. SmartStop Self Storage may refuse any bid and may rescind any purchase up until the winning bidder takes possession of the personal property. Please contact the property with any questions (239) 241-3897.

January 3, 10, 2025 25-00001C

FIRST INSERTION

NOTICE OF PUBLIC SALE OF PERSONAL PROPERTY

Please take notice SmartStop Self Storage located at 7755 Preserve Ln Naples, FL 34119, intends to hold an auction of the goods stored in the following units to satisfy the lien of the owner. The sale will occur as an online auction via www.selfstorageauction.com on 01/23/2025 at 2:30pm. Contents include personal property along with the described belongings to those individuals listed below

2165 Brett Huntley boxes, bags, totes
3278 Benjamin Steiner boxes crates furniture
3282 Benjamin Steiner boxes crates furniture

Purchases must be paid at the above referenced facility in order to complete the transaction. SmartStop Self Storage may refuse any bid and may rescind any purchase up until the winning bidder takes possession of the personal property. Please contact the property with any questions (239)-207-6132.

January 3, 10, 2025 25-00002C

FIRST INSERTION

NOTICE OF PUBLIC SALE

Extra Space Storage will hold a public auction to sell personal property described below belonging to those individuals listed below at the location indicated: 7377 Rattlesnake Hammock Rd, Naples FL 34113. Phone: 239-303-8462 Auction Date: 01/23/2025 Time: 12:15 pm

Charles Pike Household Goods
James Holmes Household Goods

The auction will be listed and advertised on www.storagetreasures.com. Purchases must be made with cash only and paid at the above referenced facility in order to complete the transaction. Extra Space may refuse any bid and may rescind any purchase up until the winning bidder takes possession of the personal property.

January 3, 10, 2025 25-00003C

FIRST INSERTION

NOTICE OF PUBLIC SALE

Extra Space Storage, on behalf of itself or its affiliates, Life Storage or Storage Express, will hold a public auction to sell personal property described below belonging to those individuals listed below at the location indicated: 571 Airport Pulling Rd N Naples, FL 34104 Auction Date: 01/23/2025 Time: 10:15 AM

Rosalind Gedeon Household Items
Michael Duran Household/Garage Items
Jeff Tanguay Household Items
Anthony Washburn Household Items

The auction will be listed and advertised on www.storagetreasures.com. Purchases must be made with cash only and paid at the above referenced facility in order to complete the transaction. Extra Space Storage may refuse any bid and may rescind any purchase up until the winning bidder takes possession of the personal property.

January 3, 10, 2025 25-00004C

FIRST INSERTION

NOTICE OF PUBLIC SALE

Extra Space Storage will hold a public auction to sell personal property described below belonging to those individuals listed below at the location indicated: 7391 Rattlesnake Hammock Rd, Naples, FL 34113 Phone: 239-303-8462 Auction Date: 1/23/25 @12:15 PM

Anastasia Williams Household Goods

The auction will be listed and advertised on www.storagetreasures.com. Purchases must be made with cash only and paid at the above referenced facility in order to complete the transaction. Extra Space may refuse any bid and may rescind any purchase up until the winning bidder takes possession of the personal property.

January 3, 10, 2025 25-00005C

FIRST INSERTION

NOTICE OF PUBLIC SALE:

THE LOCK UP SELF STORAGE at 2295 Tamiami Trail E, Naples, FL 34112 will sell the contents of the following units to satisfy a lien to the highest bidder on January 29, 2025 by 10:00 AM at WWW.STORAGETREASURES.COM.

All goods must be removed from the unit within 48 hours. Unit availability subject to prior settlement of account.

Unit 2028 - Victoria Johnson - furniture, boxes, decor
Unit 3523 - Paul Bihari - toys and clothing

January 3, 10, 2025 25-00008C

FIRST INSERTION

NOTICE OF PUBLIC AUCTION

Notice of Public Auction for money due on storage units. Auctions will be held on January 20, 2025, at 2001 E Tamiami Trail Naples, FL 34112 at or after 8am and will continue until finished. Units are said to contain household items. Property sold under

Florida Statute 83.806. The names of whose unit will be sold as follows

Elizabeth Sweeting C7 \$324.70
Jamie Rumberger C15 \$359.40
Jesenia Reyes D12 \$544.10
Cherie Jones D13 \$478.25

January 3, 10, 2025 25-00009C

FIRST INSERTION

NOTICE TO CREDITORS IN THE CIRCUIT COURT FOR COLLIER COUNTY, FLORIDA PROBATE DIVISION

File No. 24-CP-003074
IN RE: ESTATE OF

SHIRLEY MAE PETERSON a/k/a SHIRLEY M. PETERSON Deceased.

The administration of the estate of SHIRLEY MAE PETERSON a/k/a SHIRLEY M. PETERSON, deceased, whose date of death was July 11, 2024; File Number 24-CP-003074, is pending in the Circuit Court for Collier County, Florida, Probate Division, the address of which is 3315 Tamiami Trail East, Suite #102, Naples, FL 34112-5324. The names and addresses of the personal representative and the personal representative's attorney are set forth below.

All creditors of the decedent and other persons having claims or demands against decedent's estate, on whom a copy of this notice is required to be served must file their claims with this court WITHIN THE LATER OF 3 MONTHS AFTER THE TIME OF THE FIRST PUBLICATION OF THIS NOTICE OR 30 DAYS AFTER THE DATE OF SERVICE OF A COPY OF THIS NOTICE ON THEM.

All other creditors of the decedent

and other persons having claims or demands against decedent's estate must file their claims with this court WITHIN 3 MONTHS AFTER THE DATE OF THE FIRST PUBLICATION OF THIS NOTICE.

ALL CLAIMS NOT FILED WITHIN THE TIME PERIODS SET FORTH IN SECTION 733.702 OF THE FLORIDA PROBATE CODE WILL BE FOREVER BARRED.

NOTWITHSTANDING THE TIME PERIOD SET FORTH ABOVE, ANY CLAIM FILED TWO (2) YEARS OR MORE AFTER THE DECEDENT'S DATE OF DEATH IS BARRED.

The date of first publication of this notice is: January 3, 2025.

BRADLEY MORRIS PETERSON a/k/a BRADLEY M. PETERSON Personal Representative c/o A. ERIC ANDERSON, P.A. 350 Fifth Avenue South, Suite 200 Naples, Florida 34102

A. ERIC ANDERSON Attorney for Personal Representative Florida Bar No. 0322865 A. ERIC ANDERSON, P.A. 350 Fifth Avenue South, Suite 200 Naples, Florida 34102 Telephone: (239) 262-7748 Facsimile: (239) 262-7144 January 3, 10, 2025 25-00006C

FIRST INSERTION

NOTICE TO CREDITORS IN THE CIRCUIT COURT FOR COLLIER COUNTY, FLORIDA

File No. 11-2024-CP-003470-0001-01

Division: PROBATE

IN RE: ESTATE OF

JEFFREY NEIL BERES a/k/a JEFFREY N. BERES Deceased.

The administration of the estate of Jeffrey Neil Beres, a/k/a Jeffrey N. Beres, deceased, whose date of death was November 5, 2024, is pending in the Circuit Court for Collier County, Florida, Probate Division, the address of which is 3315 Tamiami Trail East, Suite 102, Naples, FL 34112. The names and addresses of the personal representative and the personal representative's attorney are set forth below.

All creditors of the decedent and other persons having claims or demands against decedent's estate on whom a copy of this notice is required to be served must file their claims with this court ON OR BEFORE THE LATER OF 3 MONTHS AFTER THE TIME OF THE FIRST PUBLICATION OF THIS NOTICE OR 30 DAYS AFTER THE DATE OF SERVICE OF A COPY OF THIS NOTICE ON THEM.

The personal representative has no duty to discover whether any property held at the time of the decedent's death by the decedent or the decedent's surviving spouse is property to which the Florida Uniform Disposition of Community Property Rights at Death Act as described in ss. 732.216-732.228, Florida Statutes, applies, or may apply,

unless a written demand is made by a creditor as specified under s. 732.2211, Florida Statutes.

All other creditors of the decedent and other persons having claims or demands against decedent's estate must file their claims with this court WITHIN 3 MONTHS AFTER THE DATE OF THE FIRST PUBLICATION OF THIS NOTICE.

ALL CLAIMS NOT FILED WITHIN THE TIME PERIODS SET FORTH IN FLORIDA STATUTES SECTION 733.702 WILL BE FOREVER BARRED.

NOTWITHSTANDING THE TIME PERIODS SET FORTH ABOVE, ANY CLAIM FILED TWO (2) YEARS OR MORE AFTER THE DECEDENT'S DATE OF DEATH IS BARRED.

The date of first publication of this notice is 01/03/2025.

Personal Representative: /S/ ROY BERES Roy Beres 10800 Kirtland Lakes Blvd. Kirtland, Ohio 44094

Attorney for Personal Representative: /S/ ROBERT H. EARDLEY Robert H. Eardley Florida Bar Number: 500631 Law Office of Robert H. Eardley, P.A. 1415 Panther Lane, Suite 108 Naples, Florida 34109 Telephone: (239) 591-6776 Fax: (239) 591-6777 E-Mail: robert@swflorida-law.com Secondary E-Mail: debra@swflorida-law.com January 3, 10, 2025 25-00007C

FIRST INSERTION

NOTICE TO CREDITORS IN THE CIRCUIT COURT FOR COLLIER COUNTY, FLORIDA PROBATE DIVISION

File No. 24-CP-003541
IN RE: ESTATE OF HELEN HARTMAN CHATLAIN Deceased.

The administration of the estate of HELEN HARTMAN CHATLAIN, deceased, whose date of death was October 18, 2024; File Number 24-CP-003541, is pending in the Circuit Court for Collier County, Florida, Probate Division, the address of which is 3315 Tamiami Trail East, Suite #102, Naples, FL 34112-5324. The names and addresses of the personal representative and the personal representative's attorney are set forth below.

All creditors of the decedent and other persons having claims or demands against decedent's estate, on whom a copy of this notice is required to be served must file their claims with this court WITHIN THE LATER OF 3 MONTHS AFTER THE TIME OF THE FIRST PUBLICATION OF THIS NOTICE OR 30 DAYS AFTER THE DATE OF SERVICE OF A COPY OF THIS NOTICE ON THEM.

All other creditors of the decedent and other persons having claims or demands against decedent's estate must file their claims with this court WITHIN 3 MONTHS AFTER THE DATE OF THE FIRST PUBLICATION OF THIS NOTICE.

ALL CLAIMS NOT FILED WITHIN THE TIME PERIODS SET FORTH IN SECTION 733.702 OF THE FLORIDA PROBATE CODE WILL BE FOREVER BARRED.

NOTWITHSTANDING THE TIME PERIOD SET FORTH ABOVE, ANY CLAIM FILED TWO (2) YEARS OR MORE AFTER THE DECEDENT'S DATE OF DEATH IS BARRED.

The date of first publication of this notice is: January 3, 2025.

ERIC E. CHATLAIN Personal Representative c/o A. ERIC ANDERSON, P.A. 350 Fifth Avenue South, Suite 200 Naples, Florida 34102

A. ERIC ANDERSON Attorney for Personal Representative Florida Bar No. 0322865 A. ERIC ANDERSON, P.A. 350 Fifth Avenue South, Suite 200 Naples, Florida 34102 Telephone: (239) 262-7748 Facsimile: (239) 262-7144 January 3, 10, 2025 25-00012C

FIRST INSERTION

Notice of Self Storage Sale

Please take notice US Storage Centers - Orlando - Colonial located at 6205 W Colonial Dr Orlando FL 32808 intends to hold a sale to sell the property stored at the Facility by the below list of Occupants whom are in default at an Auction. The sale will occur as an online auction via www.storagetreasures.com on 01/21/2025 at 10:00 AM. Unless stated otherwise the description of the contents

are household goods, furnishings and garage essentials. Johnny Tesant Unit #2180; Camisha Hawkins Unit #1010; Tasha Bellevue Unit #1031; Corey Fenelon Unit #2064; Jeffrey Silvernale Unit #2050; Shela Pierre Unit #2183; Eric McDaniels Unit #3241; Hassan Adnan Unit #2051. This sale may be withdrawn at any time without notice. Certain terms and conditions apply. See manager for details.
January 3, 10, 2025 25-00010C

FIRST INSERTION

NOTICE OF PUBLIC SALE

Extra Space Storage, on behalf of itself or its affiliates, Life Storage or Storage Express, will hold a public auction to sell personal property described below belonging to those individuals listed below at the location indicated: 8471 Davis Blvd. Naples, FL 34104 on: 01/23/2025 @10:45am.

Tenant Name: Nayma Alvarez
General Description of Property: Misc. Personal Items
Tenant Name: Teressa Kerbo
General Description of Property: Misc. Personal Items

The auction will be listed and advertised on www.storagetreasures.com. Purchases must be made with cash only and paid at the above referenced facility in order to complete the transaction. Extra Space Storage may refuse any bid and may rescind any purchase up until the winning bidder takes possession of the personal property.

January 3, 10, 2025 25-00015C

HOW TO PUBLISH YOUR LEGAL NOTICE IN THE BUSINESS OBSERVER

CALL 941-906-9386 and select the appropriate County name from the menu option OR E-MAIL: legal@businessobserverfl.com

FIRST INSERTION

NOTICE OF ACTION FOR PETITION FOR APPOINTMENT OF GUARDIAN OF MINOR IN THE CIRCUIT COURT OF THE TWENTIETH JUDICIAL CIRCUIT, IN AND FOR COLLIER COUNTY, FLORIDA

Case No.: 2024-GA-291
Judge: Russell T. Kirshy
IN RE GUARDIANSHIP OF: REBECCA ANNE NELSON, a Minor,

TO RESPONDENT: SARAH ELIZABETH KELLAS RESPONDENTS LAST KNOWN ADDRESS: UNKNOWN

YOU ARE NOTIFIED that an action Petition for Appointment of Guardian of Minor has been filed against you and that you are required to serve a copy of your written defenses, if any, to Petitioner's Attorney, Sarah M. Oquendo, Esq., of Coleman, Taylor, Klaus, Doupe, Diaz & Torrez, P.A., at 4099 Tamiami Trail North, Suite 201, Naples, Florida, 34103 on or before 1/28/2025, and file the original with the clerk of this Court at 3315 Tamiami Trail East, Naples, Florida 34112, before service on Petitioner or immediately thereafter. If you fail to do so, a default may be entered against you for the relief demanded in the petition.

Copies of all court documents in this case, including orders, are available at the Clerk of the Circuit Court's office. You may review these documents upon request.

You must keep the Clerk of the Circuit Court's office notified of your current address. (You may file Designation of Current Mailing and E-Mail Address, Florida Supreme Court Approved Family Law Form 12.915.) Future papers in this lawsuit will be mailed or e-mailed to the addresses on record at the clerk's office.

WARNING: Rule 12.285, Florida Family Law Rules of Procedure, requires certain automatic disclosure of documents and information. Failure to comply can result in sanctions, including dismissal or striking of pleadings.

Dated on: December 26, 2024.
CRYSTAL K. KINZEL CLERK OF THE CIRCUIT COURT (SEAL) By: /s/Mark Pomplas As Deputy Clerk

Petitioner's Attorney, Sarah M. Oquendo, Esq., Coleman, Taylor, Klaus, Doupe, Diaz & Torrez, P.A., 4099 Tamiami Trail North, Suite 201, Naples, Florida 34103
January 3, 10, 17, 24, 2025

25-00011C

FIRST INSERTION

Fictitious Name Notice

Notice is hereby given that ELENA BARROWS, OWNER, desiring to engage in business under the fictitious name of NAPLES FLOWERS BOUTIQUE located at 6823 SAONA CT, NAPLES, FLORIDA 34113 intends to register the said name in COLLIER county with the Division of Corporations, Florida Department of State, pursuant to section 865.09 of the Florida Statutes.

January 3, 2025 25-00013C

OFFICIAL COURTHOUSE WEBSITES

manateeclerk.com
sarasotaclerk.com
charlotteclerk.com
leeclerk.org
collierclerk.com
hillsclerk.com
pascoclerk.com
mypinellasclerk.gov
polkcountyclerk.net
myorangeclerk.com

FIRST INSERTION

NOTICE TO CREDITORS IN THE CIRCUIT COURT FOR COLLIER COUNTY, FLORIDA PROBATE DIVISION

File No. 11-2024-CP-003494-0001-01

Division: PROBATE
IN RE: ESTATE OF JOHN IVO MIDDAGH a/k/a JOHN I. MIDDAGH Deceased.

The administration of the estate of John Ivo Middagh a/k/a John I. Middagh, deceased, whose date of death was November 14, 2024, is pending in the Circuit Court for Collier County, Florida, Probate Division, the address of which is 3315 Tamiami Trail East, Suite 102, Naples, Florida 34112-5324. The names and addresses of the personal representative and the personal representative's attorney are set forth below.

All creditors of the decedent and other persons having claims or demands against decedent's estate on whom a copy of this notice is required to be served must file their claims with this court ON OR BEFORE THE LATER OF 3 MONTHS AFTER THE TIME OF THE FIRST PUBLICATION OF THIS NOTICE OR 30 DAYS AFTER THE DATE OF SERVICE OF A COPY OF THIS NOTICE ON THEM.

The personal representative has no duty to discover whether any property held at the time of the decedent's death by the decedent or the decedent's surviving spouse is property to which the Florida Uniform Disposition of Community Property Rights at Death Act as described in ss. 732.216-732.228, Florida Statutes, applies, or may apply, unless a written demand is made by a creditor as specified under s. 732.2211, Florida Statutes.

All other creditors of the decedent and other persons having claims or demands against decedent's estate must file their claims with this court WITHIN 3 MONTHS AFTER THE DATE OF THE FIRST PUBLICATION OF THIS NOTICE.

ALL CLAIMS NOT FILED WITHIN THE TIME PERIODS SET FORTH IN FLORIDA STATUTES SECTION 733.702 WILL BE FOREVER BARRED.

NOTWITHSTANDING THE TIME PERIODS SET FORTH ABOVE, ANY CLAIM FILED TWO (2) YEARS OR MORE AFTER THE DECEDENT'S DATE OF DEATH IS BARRED.

The date of first publication of this notice is January 3, 2025

Personal Representative: /s/ Glen D. Middaugh Glen D. Middaugh 4351 E. Old Fort Harrison Avenue Terre Haute, Indiana 47805

/s/ A. Stephen Kotler A. Stephen Kotler Florida Bar Number: 629103 KOTLER LAW FIRM P.L. 999 Vanderbilt Beach Road, Suite 200 Naples, Florida 34108 Telephone: (239) 325-2333 Fax: (239) 325-1853 E-Mail: skotler@kotlerpl.com Secondary E-Mail: paralegal@kotlerpl.com January 3, 10, 2025 25-00014C

PUBLISH YOUR LEGAL NOTICE

We publish all Public sale, Estate & Court-related notices

- We offer an online payment portal for easy credit card payment
- Service includes us e-filing your affidavit to the Clerk's office on your behalf
- Simply email your notice to legal@businessobserverfl.com

FLORIDA'S NEWSPAPER FOR THE COURTS
Business Observer

Q&A

Who benefits from legal notices?

You do. Legal notices are required because a government body or corporation wants to take action that can affect individuals and the public at large.

When the government is about to change your life, or your property or assets are about to be taken, public notices in newspapers serve to alert those affected.

Are there different types of legal notices?

Simply put, there are two basic types - Warning Notices and Accountability Notices.

Warning notices inform you when government, or a private party authorized by the government, is about to do something that may affect your life, liberty or pursuit of happiness. Warning notices typically are published more than once over a certain period.

Accountability notices are designed to make sure citizens know details about their government. These notices generally are published one time, and are archived for everyone to see. Accountability is key to efficiency in government.

Are internet-only legal notices sufficient?

No. While the internet is clearly a useful resource, websites should not be used as the sole source of a legal notice.

Websites, whether controlled by a government body or a private firm, are not independent, archived, readily available or independently verified.

Newspaper legal notices fulfill all of those standards.

How much do legal notices cost?

The price for notices in the printed newspaper must include all costs for publishing the ad in print, on the newspaper's website and to www.floridapublicnotices.com.

The public is well-served by notices published in a community newspaper.

VIEW NOTICES ONLINE AT
Legals.BusinessObserverFL.com

To publish your legal notice Email:
legal@businessobserverfl.com

--- ESTATE ---

FIRST INSERTION

REVISED NOTICE TO CREDITORS

IN THE CIRCUIT COURT OF THE TWENTIETH JUDICIAL CIRCUIT, IN AND FOR COLLIER COUNTY, FLORIDA
PROBATE DIVISION
CASE NO.:
11-2024-CP-003285-0001-01
IN THE RE: ESTATE OF
DAVID P. CROCKETT,
Deceased.

The administration of the estate of DAVID P. CROCKETT, deceased, whose date of death was October 14, 2024 is pending in the Circuit Court for Collier County, Florida, Probate Division, the address of which is 3315 Tamiami Trail, East, Ste. 102, Naples, Florida 34112-5432. The name and address of the Personal Representative and the

Personal Representative's attorney is set forth below.

All creditors of the Decedent and other persons having claims or demands against the Decedent's estate on whom a copy of this notice is required to be served must file their claims with this Court ON OR BEFORE THE LATER OF 3 MONTHS AFTER THE TIME OF THE FIRST PUBLICATION OF THIS NOTICE OR 30 DAYS AFTER THE DATE OF SERVICE OF A COPY OF THIS NOTICE ON THEM.

All other creditors of the Decedent and other persons having claims or demands against Decedent's estate must file their claims with this Court WITHIN 3 MONTHS AFTER THE DATE OF THE FIRST PUBLICATION OF THIS NOTICE.

The personal representative has no duty to discover whether any property held at the time of the decedent's death by the decedent or the decedent's surviving spouse is property to which the Florida Uniform Disposition of Community Property Rights at Death Act as described in ss. 732.216-732.228, applies, or may apply, unless a written demand is made by a creditor as specified under s. 732.2211, Florida Statutes.

ALL CLAIMS NOT FILED WITHIN THE TIME PERIODS SET FORTH IN FLORIDA STATUTES SECTION 733.702 WILL BE FOREVER BARRED.

NOTWITHSTANDING THE TIME PERIODS SET FORTH ABOVE, ANY CLAIM FILED TWO (2) YEARS OR MORE AFTER THE DECEDENT'S DATE OF DEATH IS BARRED.

The date of first publication of this notice is January 3, 2024.

Personal Representative
Kelli M. Crockett
c/o Michael Allen Azre, LPA, Inc.
2460 Fairmount Boulevard,
Suite 210
Cleveland Heights, Ohio 44106
(216) 678-4097
Email: maa@mazrelaw.com
Attorney for Personal Representative
Michael Allen Azre, Esq.
Attorney for Beneficiary
Florida Bar No.: 83522
Michael Allen Azre, LPA, Inc.
2460 Fairmount Boulevard,
Suite 210
Cleveland Heights, Ohio 44106
(216) 678-4097
Email: maa@mazrelaw.com
January 3, 10, 2025 25-00016C

SUBSEQUENT INSERTIONS

--- ESTATE / ACTIONS ---

FOURTH INSERTION

NOTICE OF ACTION OF PETITION FOR DISSOLUTION OF MARRIAGE AND OTHER RELIEF
IN THE CIRCUIT COURT OF THE TWENTIETH JUDICIAL CIRCUIT IN AND FOR COLLIER COUNTY, FLORIDA
FAMILY DIVISION
CASE NO.: 24-DR-1489

IN RE: THE MARRIAGE OF:
ASHLEY NICOLE SHAFMAN
Petitioner, and
LUIGI BORNA PAPARELLA
Respondent.

TO: LUIGI BORNA PAPARELLA
3735 Shrine Park Road
Leavenworth, Kansas 66048

Physical Description:
Age: 27; Race: Caucasian; Hair Color: Brown; Height: 6'04"; Date of Birth: September 2, 1997

YOU ARE NOTIFIED that an action for Dissolution of Marriage has been filed against you and that you are required to serve a copy of your written defenses, if any, to it on the Petitioner, ASHLEY NICOLE SHAFMAN, to Brenda Marie Miranda, Esquire, c/o Family First Legal Group, 2950 Immokalee Road, Suite 2, Naples, Florida 34110 on or before Friday, January 10, 2025 and file the original with the Clerk of this Court at 3315 Tamiami Trail

East, Suite 102, Naples, Florida 34112, before service on Petitioner or immediately thereafter. If you fail to do so, a default may be entered against you for the relief demanded in the Petition.

Copies of all court documents in this case, including orders, are available at the Clerk of the Circuit Court's office. You may review these documents upon request.

You must keep the Clerk of the Circuit Court's office notified of your current address. (You may file Notice of Current Address, Florida Supreme Court Approved Family Law Form 12.915.) Future papers in this lawsuit will be mailed to the address on record at the clerk's office.

WARNING: Rule 12.285, Florida Family Law Rules of Procedure, requires certain automatic disclosure of documents and information. Failure to comply can result in sanctions, including dismissal or striking of pleadings.

Dated: 12-4-24
CLERK OF THE CIRCUIT COURT (SEAL) By: Esmerelda Santiago
11-2024-DR-001489-FM01-01
12/4/2024
Deputy Clerk
Dec. 13, 20, 27, 2024; Jan. 3, 2025
24-02155C

FOURTH INSERTION

NOTICE OF ACTION
IN THE CIRCUIT COURT OF THE TWENTIETH JUDICIAL CIRCUIT IN AND FOR COLLIER COUNTY, FLORIDA
CIVIL DIVISION
Case No. 24-CA-1713

JAMES CAPUTO,
Plaintiff, v.
DONNA MOLINARO, VIOLETTA BALCEROWICZ, TOMASZ PIOTR WYWIOL, and ALBERT PIOTR WYWIOL
Defendants.

TO: ALBERT PIOTR WYWIOL
5720 LANCEWOOD WAY
NAPLES, FL 34116

YOU ARE HEREBY NOTIFIED that a quiet title action on the following real property located in Collier County, Florida:

Lot 43 of Block 4, in BONITA SHORES (Unit No. 1), according to the plat thereof in Plat Book 3 at Page 1, Public Records of Collier County, Florida.

Parcel Identification Number: 24474720002
has been filed against you, ALBERT PIOTR WYWIOL and you are required to

serve a copy of your written defenses, if any, to it on Plaintiff's attorney, whose name and address is as follows:

Mikala M. Makar, Esquire
Roetzel & Andress, LPA
999 Vanderbilt Beach Rd.,
Suite 401
Naples, FL 34108

and file the original with the Clerk of this Court either before service on Plaintiff's Attorney or immediately thereafter on or before thirty (30) days after the first publication of this Notice; or otherwise a default will be entered against you for the relief demanded in the Complaint for Quiet Title.

Dated on: 12/3/2024.
CRYSTAL K. KINZEL,
CLERK OF COURTS
(Seal) By: Yliana Mirabal
11-2024-CA-001713-0001-01
12/3/2024
Deputy Clerk

Mikala M. Makar, Esquire
Roetzel & Andress, LPA
999 Vanderbilt Beach Rd., Suite 401
Naples, FL 34108
Dec. 13, 20, 27, 2024; Jan. 3, 2025
24-02153C

SECOND INSERTION

NOTICE TO CREDITORS
IN THE CIRCUIT COURT FOR THE 20TH JUDICIAL CIRCUIT, IN AND FOR COLLIER COUNTY, FLORIDA
PROBATE DIVISION

File No.
11-2024-CP-003233-0001-01
IN RE: ESTATE OF
NATURI QUANAYZAH MCCLAIN
Deceased.

The administration of the estate of NATURI QUANAYZAH MCCLAIN, Deceased, whose date of death was September 13, 2024, is pending in the Circuit Court for COLLIER County, Florida, Probate Division, the address of which is 3315 Tamiami Trail East, Naples, FL 34112. The names and addresses of the personal representative and the personal representative's attorney are set forth below.

All creditors of the decedent and other persons having claims or demands against decedent's estate on whom a copy of this notice is required to be served must file their claims with this court WITHIN THE LATER OF 3 MONTHS AFTER THE TIME OF THE FIRST PUBLICATION OF THIS NOTICE OR 30 DAYS AFTER THE DATE OF SERVICE OF A COPY OF THIS NOTICE ON THEM.

All other creditors of the decedent and other persons having claims or demands against decedent's estate must file their claims with this court WITHIN 3 MONTHS AFTER THE DATE OF THE FIRST PUBLICATION OF THIS NOTICE.

ALL CLAIMS NOT FILED WITHIN THE TIME PERIODS SET FORTH IN SECTION 733.702 OF THE FLORIDA PROBATE CODE WILL BE FOREVER BARRED.

NOTWITHSTANDING THE TIME PERIODS SET FORTH ABOVE, ANY CLAIM FILED TWO (2) YEARS OR MORE AFTER THE DECEDENT'S DATE OF DEATH IS BARRED.

A personal representative or curator has no duty to discover whether any property held at the time of the decedent's death by the decedent or the decedent's surviving spouse is property to which the Florida Uniform Disposition of Community Property Rights at Death Act as described in sections 732.216-732.228, applies, or may apply, unless a written demand is made by a creditor as specified under section 732.2211.

The date of first publication of this notice is December 27, 2024.

JOHN LESTER SHORT,
Personal Representative
Attorney for Personal Representative:
Scott R. Bugay, Esquire
Florida Bar No. 5207
Citicentre, Suite P600
290 NW 165 Street
Miami FL 33169
Telephone: (305) 956-9040
Fax: (305) 945-2905
Primary Email:
Scott@srblawyers.com
Secondary Email:
angelica@srblawyers.com
Dec. 27, 2024; Jan. 3, 2025
24-02227C

PUBLISH YOUR LEGAL NOTICE

We publish all Public sale, Estate & Court-related notices

- Simply email your notice to legal@businessobserverfl.com
- We offer an online payment portal for easy credit card payment
- Service includes us e-filing your affidavit to the Clerk's office on your behalf

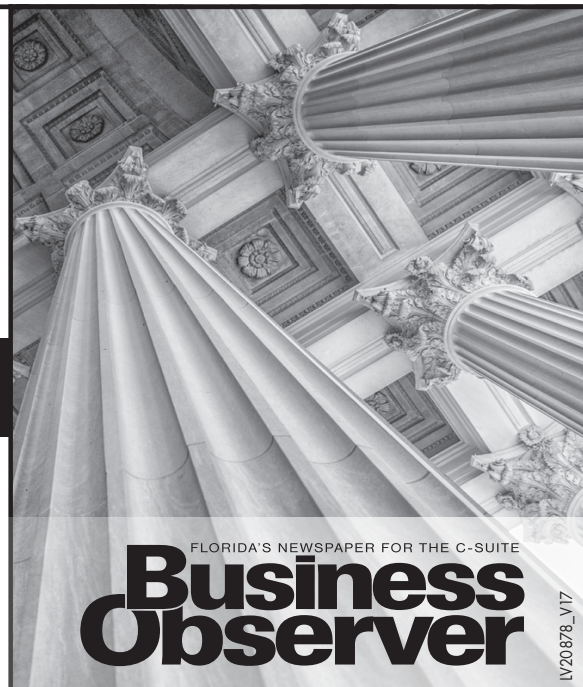

FLORIDA'S NEWSPAPER FOR THE C-SUITE
Business Observer

--- ACTIONS / SALES / ESTATES ---

SECOND INSERTION

RE-NOTICE OF FORECLOSURE SALE

IN THE CIRCUIT COURT OF THE TWENTIETH JUDICIAL CIRCUIT, IN AND FOR COLLIER COUNTY, FLORIDA

CASE NO. 2018-CA-000557
U.S. BANK NATIONAL ASSOCIATION, AS TRUSTEE, FOR THE C-BASS MORTGAGE LOAN ASSET BACKED CERTIFICATES, SERIES 2007-RP1, Plaintiff, vs. PATRICIA WILLIAMS A/K/A PATRICIA WILLIAMS-THOMPSON; UNKNOWN SPOUSE OF PATRICIA WILLIAMS A/K/A PATRICIA WILLIAMS-THOMPSON N/K/A TROY THOMPSON, ET AL. Defendants

NOTICE IS HEREBY GIVEN that pursuant to an Order Rescheduling the Foreclosure Sale dated December 17, 2024 entered in Case No. 2018-CA-000557 in the Circuit Court of the Twentieth Judicial Circuit in and for COLLIER County, Florida. U.S. BANK NATIONAL ASSOCIATION, AS TRUSTEE, FOR THE C-BASS MORTGAGE LOAN ASSET BACKED CERTIFICATES, SERIES 2007-RP1 (hereafter "Plaintiff") and PATRICIA WILLIAMS A/K/A PATRICIA WILLIAMS-THOMPSON; UNKNOWN SPOUSE OF PATRICIA WILLIAMS A/K/A PATRICIA WILLIAMS-THOMPSON N/K/A TROY THOMPSON ("Defendants"). Crystal K. Kinzel, Clerk of the Circuit Court for COLLIER, County Florida will sell to the highest and best bidder for cash in the Multipurpose Room of the 1st Floor Customer Service Department, Courthouse Annex, Collier County Courthouse, 3315 Tamiami Trail East, Naples, Florida 34112, at 11:00 a.m., on the 23RD day of JANUARY, 2025, the following described property as set forth in said Final Judgment, to wit

THE NORTH ONE-HALF OF TRACT NO. 113 GOLDEN GATE ESTATES, UNIT NO. 50, ACCORDING TO THE PLAT THEREOF RECORDED IN PLAT BOOK 5, PAGES 82 AND 83, OF THE PUBLIC RECORDS OF COLLIER COUNTY, FLORIDA.

If you are a person with a disability who needs any accommodation in order to participate in this proceeding, you are entitled, at no cost to you, to the provision of certain assistance. Please

contact Charles Rice, Administrative Services Manager Phone no. 239-252-8800, Fax no. 239-252-8272, via Email: charlesr@ca.cjis20.org at least 7 days before your scheduled court appearance, or immediately upon receiving this notification if the time before the scheduled appearance is less than 7 days; if you are hearing or voice impaired, call 711

Si usted es una persona minusválida que necesita algún acomodamiento para poder participar en este procedimiento, usted tiene derecho, sin tener gastos propios, a que se le provea cierta ayuda. Tenga la amabilidad de ponerse en contacto con Charles Rice, Administrativa Services Manager Phone no. 239-252-8800, Fax no. 239-252-8272, via Email: charlesr@ca.cjis20.org por lo menos 7 días antes de la cita fijada para su comparecencia en los tribunales, o inmediatamente después de recibir esta notificación si el tiempo antes de la comparecencia que se ha programado es menos de 7 días; si usted tiene discapacidad del oído o de la voz, llame al 711.

Si ou se yon moun ki andikape ou enfim ki bezwen akomodasyon pou w ka patisipe nan pwosedi sa, ou kalifye sa ou pa gen okenn lajan pou w peye, gen pwovizyon pou jwen kèk èd. Tanpri kontakte Charles Rice, Administrativa Services Manager Phone no. 239-252-8800, Fax no. 239-252-8272, via Email: charlesr@ca.cjis20.org nan 7 jou anvan dat ou gen randevou pou parèt nan tribinal la, oubyen imedyatman apre ou fin resevwa konvokasyon an si lè ou gen pou w parèt nan tribinal la mwens ke 7 jou; si ou gen pwoblèm pou w tande oubyen pale, rele 711.

Any person claiming an interest in the surplus from the sale, if any, other than the property owner as of the date of the lis pendens must file a claim before the clerk reports the surplus as unclaimed.

Dated this 19th day of December, 2024.

VAN NESS LAW FIRM, PLC
1239 E. Newport Center Drive, Suite 110
Deerfield Beach, Florida 33442
Ph: (954) 571-2031
PRIMARY EMAIL:
Pleadings@vanlawfl.com
/S/MARK C. ELIA
Mark C. Elia, Esq.
Bar Number: 695734
PHH3128-15/sap
Dec. 27, 2024; Jan. 3, 2025

24-02224C

FOURTH INSERTION

NOTICE OF ACTION
IN THE CIRCUIT COURT OF THE TWENTIETH JUDICIAL CIRCUIT IN AND FOR COLLIER COUNTY, FLORIDA
CIVIL DIVISION
Case No. 24-CA-1713

JAMES CAPUTO, Plaintiff, v. DONNA MOLINARO, VIOLETTA BALCEROWICZ, TOMASZ PIOTR WYWIOL, and ALBERT PIOTR WYWIOL. Defendants.

TO: TOMASZ PIOTR WYWIOL
2125 TAMMA CIRCLE, UNIT 102
NAPLES, FL 34112
TOMASZ PIOTR WYWIOL
5720 LANCEWOOD WAY
NAPLES, FL 34116
TOMASZ PIOTR WYWIOL
31 2ND STREET
BONITA SPRINGS, FL 34134

YOU ARE HEREBY NOTIFIED that a quiet title action on the following real property located in Collier County, Florida:

Lot 43 of Block 4, in BONITA SHORES (Unit No. 1), according to the plat thereof in Plat Book 3 at Page 1, Public Records of Collier County, Florida.
Parcel Identification Number: 24474720002

has been filed against you, TOMASZ PIOTR WYWIOL and you are required to serve a copy of your written defenses, if any, to it on Plaintiff's attorney, whose name and address is as follows:

Mikala M. Makar, Esquire
Roetzel & Andress, LPA
999 Vanderbilt Beach Rd., Suite 401
Naples, FL 34108

and file the original with the Clerk of this Court either before service on Plaintiff's Attorney or immediately thereafter on or before thirty (30) days after the first publication of this Notice; or otherwise a default will be entered against you for the relief demanded in the Complaint for Quiet Title.

Dated on: 12/3/2024.

CRYSTAL K. KINZEL, CLERK OF COURTS
(Seal) By: Yliana Mirabal
11-2024-CA-001713-0001-01
12/3/2024
Deputy Clerk

Mikala M. Makar, Esquire
Roetzel & Andress, LPA
999 Vanderbilt Beach Rd., Suite 401
Naples, FL 34108
22409362_1 151513.0001
Dec. 13, 20, 27, 2024; Jan. 3, 2025
24-02151C

SECOND INSERTION

NOTICE TO CREDITORS
IN THE CIRCUIT COURT FOR COLLIER COUNTY, FLORIDA
PROBATE DIVISION
File No. 2024-CP-3512
Division Probate
IN RE: ESTATE OF DAVID W. CLARK
Deceased.

The administration of the estate of David W. Clark, deceased, whose date of death was October 2, 2024, is pending in the Circuit Court for Collier County, Florida, Probate Division, the address of which is 3315 Tamiami Trail E., Naples, FL 34112. The names and addresses of the personal representative and the personal representative's attorney are set forth below.

All creditors of the decedent and other persons having claims or demands against decedent's estate on whom a copy of this notice is required to be served must file their claims with this court ON OR BEFORE THE LATER OF 3 MONTHS AFTER THE TIME OF THE FIRST PUBLICATION OF THIS NOTICE OR 30 DAYS AFTER THE DATE OF SERVICE OF A COPY OF THIS NOTICE ON THEM.

The personal representative has no duty to discover whether any property held at the time of the decedent's death by the decedent or the decedent's surviving spouse is property to which the Florida Uniform Disposition of Community Property Rights at Death Act as described in ss. 732.216-732.228, Florida Statutes, applies, or may apply, unless a written demand is made by a

creditor as specified under s. 732.2211, Florida Statutes.

All other creditors of the decedent and other persons having claims or demands against decedent's estate must file their claims with this court WITHIN 3 MONTHS AFTER THE DATE OF THE FIRST PUBLICATION OF THIS NOTICE.

ALL CLAIMS NOT FILED WITHIN THE TIME PERIODS SET FORTH IN FLORIDA STATUTES SECTION 733.702 WILL BE FOREVER BARRED.

NOTWITHSTANDING THE TIME PERIODS SET FORTH ABOVE, ANY CLAIM FILED TWO (2) YEARS OR MORE AFTER THE DECEDENT'S DATE OF DEATH IS BARRED.

The date of first publication of this notice is 12/27/2024.

Personal Representative:
/s/ Sarah McNally
Sarah McNally
6432 Renaissance Drive
Post Orange, Florida 32128

Attorney for Personal Representative:
/s/ Jeffrey R. Grant
Jeffrey R. Grant, Attorney
Florida Bar Number: 63918
Grant Cottrell, PLLC
5147 Castello Drive
Naples, FL 34103
Telephone: (239) 649-4848
Fax: (239) 643-9810
E-Mail: jeff@grantcottrell.com
Secondary E-Mail:
jennifer@grantcottrell.com
Dec. 27, 2024; Jan. 3, 2025

24-02221C

SECOND INSERTION

NOTICE TO CREDITORS
IN THE CIRCUIT COURT FOR COLLIER COUNTY, FLORIDA
PROBATE DIVISION
File No. 24-CP-2843
Division Probate
IN RE: ESTATE OF JOHN J. KENNEDY SR.,
Deceased,

The administration of the Estate of John J. Kennedy Sr., deceased, whose date of death was March 18, 2024, and the last four digits of whose social security number are x0465, is pending in the Circuit Court for Collier County, Florida, Probate Division, the address of which is 3315 Tamiami Trail East, Suite 501, Naples, FL 34112. The names and addresses of the personal representative and the personal representative's attorney are set forth below.

All creditors of the Decedent and other persons having claims or demands against Decedent's estate on whom a copy of this notice is required to be served must file their claims with this court WITHIN THE LATER OF 3 MONTHS AFTER THE TIME OF THE FIRST PUBLICATION OF THIS NOTICE OR 30 DAYS AFTER THE DATE OF SERVICE OF A COPY OF THIS NOTICE ON THEM.

The Personal Representative has no duty to discover whether any property held at the time of the Decedent's death by the Decedent or the Decedent's surviving spouse is property to which the Florida Uniform Disposition of Community Property Rights at Death Act, as

described in section 732.216-732.228, Florida Statutes, applies, or may apply, unless a written demand is filed within the time provided by section 732.2211, Florida Statutes.

All other creditors of the Decedent and other persons having claims or demands against decedent's estate must file their claims with this court WITHIN 3 MONTHS AFTER THE DATE OF THE FIRST PUBLICATION OF THIS NOTICE.

ALL CLAIMS NOT FILED WITHIN THE TIME PERIODS SET FORTH IN SECTION 733.702 OF THE FLORIDA PROBATE CODE WILL BE FOREVER BARRED.

NOTWITHSTANDING THE TIME PERIODS SET FORTH ABOVE, ANY CLAIM FILED TWO (2) YEARS OR MORE AFTER THE DECEDENT'S DATE OF DEATH IS BARRED.

The date of first publication of this notice is December 27, 2024.

Personal Representative:
Gerard E. Kennedy
7576 San Miguel Way
Naples, Florida 34109

Attorney for Personal Representative:
Amy L. McGarry
Florida Bar Number: 181897
Amy McGarry Law Office, PL
1708 Cape Coral Pkwy West, Suite 7
Cape Coral, Florida 33914
Telephone: (239) 945-3883
amy@amymcgarrylaw.com
service@amymcgarrylaw.com
Dec. 27, 2024; Jan. 3, 2025

24-02220C

SECOND INSERTION

NOTICE TO CREDITORS
IN THE CIRCUIT COURT FOR COLLIER COUNTY, FLORIDA
PROBATE DIVISION
File No. 2024-CP-003073
IN RE: ESTATE OF DAVID ROBERT MCCORMICK
Deceased.

The administration of the estate of DAVID ROBERT MCCORMICK, deceased, whose date of death was March 30, 2024, is pending in the Circuit Court for COLLIER County, Florida, Probate Division, the address of which is 3315 Tamiami Trail East, Suite 102, Naples, FL 34112. The names and addresses of the personal representative and the personal representative's attorney are set forth below.

All creditors of the decedent and other persons having claims or demands against decedent's estate on whom a copy of this notice is required to be served must file their claims with this court ON OR BEFORE THE LATER OF 3 MONTHS AFTER THE TIME OF THE FIRST PUBLICATION OF THIS NOTICE OR 30 DAYS AFTER THE DATE OF SERVICE OF A COPY OF THIS NOTICE ON THEM.

The personal representative has no duty to discover whether any property held at the time of the decedent's death by the decedent or the decedent's surviving spouse is property to which the Florida Uniform Disposition of Community Property Rights at Death Act as described in ss. 732.216-732.228, Florida Statutes, applies, or may apply, unless a written demand is made by a creditor as specified under s. 732.2211, Florida Statutes.

All other creditors of the decedent and other persons having claims or de-

mands against decedent's estate must file their claims with this court WITHIN 3 MONTHS AFTER THE DATE OF THE FIRST PUBLICATION OF THIS NOTICE.

ALL CLAIMS NOT FILED WITHIN THE TIME PERIODS SET FORTH IN FLORIDA STATUTES SECTION 733.702 WILL BE FOREVER BARRED.

NOTWITHSTANDING THE TIME PERIODS SET FORTH ABOVE, ANY CLAIM FILED TWO (2) YEARS OR MORE AFTER THE DECEDENT'S DATE OF DEATH IS BARRED.

The date of first publication of this notice is December 27, 2024.

Personal Representative:
/s/ Scott McCormick
SCOTT MCCORMICK
330 1st Street NW
Naples, Florida 34120

Attorney for Personal Representative:
/s/ Phoebe Wise
PHOEBE S. WISE
Florida Bar Number: 105652
KYLE T. MORDEW
Florida Bar Number: 1022234
HAHN LOESER & PARKS LLP
5811 Pelican Bay Blvd., Suite 650
Naples, Florida 34108
Telephone: (239) 254-2951
Fax: (239) 451-4056
E-Mail: pwise@hahnlaw.com
Secondary E-Mail:
hrodriguez@hahnlaw.com
E-Mail: kmordew@hahnlaw.com
Secondary E-Mail:
tkauer@hahnlaw.com
Secondary E-Mail:
vbaker@hahnlaw.com
Attorneys for SCOTT MCCORMICK
18030784.1
Dec. 27, 2024; Jan. 3, 2025

24-02225C

SECOND INSERTION

NOTICE OF ACTION FOR DISSOLUTION OF MARRIAGE (NO CHILD OR FINANCIAL SUPPORT)

IN RE: THE MARRIAGE OF TWENTIETH JUDICIAL CIRCUIT, IN AND FOR COLLIER COUNTY, FLORIDA
FAMILY DIVISION
CASE NO: 2024-DR-002533
IN RE: THE MARRIAGE OF RICHARD KINGSBURY, Plaintiff/Husband, and NANCY LEE LASURE, Respondent/Wife.
TO: NANCY LEE LASURE
148 EAST CYPRESS WAY, APT7
NAPLES, FL 34110

YOU ARE NOTIFIED that an action for dissolution of marriage has been filed against you and that you are required to serve a copy of your written defenses, if any, to it on Richard Kingsbury, whose address is c/o Gayle Edwards Sarju, Esquire, Law Office of Gayle Sarju, P.A., 5072 Annunciation Circle, Suite 214, Ave Maria, FL 34142, on or before 01/20/2025, and file the original with the clerk of this Court at 3315 Tamiami Trail E, Naples, FL 34112, before service on Petitioner or immediately thereafter. If you fail to do so, a default may be entered against you for the relief demanded in the petition.

Copies of all court documents in this case, including orders, are available at the Clerk of the Circuit Court's office.

You may review these documents upon request.

You must keep the Clerk of the Circuit Court's office notified of your current address. (You may file Designation of Current Mailing and E-Mail Address, Florida Supreme Court Approved Family Law Form 12.915.) Future papers in this lawsuit will be mailed or e-mailed to the addresses on record at the clerk's office.

WARNING: Rule 12.285, Florida Family Law Rules of Procedure, requires certain automatic disclosure of documents and information. Failure to comply can result in sanctions, including dismissal or striking of pleadings.

Dated: 12/12/2024.
CLERK OF THE CIRCUIT COURT (SEAL) By: /s/Tracie Osborne
11-2024-DR-02533-FM01-01
12/12/2014
{Deputy Clerk}

Respectfully submitted,
/s/ Gayle E. Sarju
Gayle E. Sarju, Esq.
Florida Bar No.: 108572
gaylesarju@gmail.com
LAW OFFICE OF GAYLE SARJU, P.A.
5070 Annunciation Circle, Suite 214
Ave Maria, Florida 34142
Telephone: (239) 658-5372
Facsimile: (239) 579-9555
Attorney for Petitioner
Dec. 27, 2024; Jan. 3, 10, 17, 2025
24-02228C

SECOND INSERTION

NOTICE TO CREDITORS
IN THE CIRCUIT COURT FOR COLLIER COUNTY, FLORIDA
PROBATE DIVISION
File No. 24-CP-3483
IN RE: ESTATE OF DONNA L. POTTER,
Deceased.

The administration of the estate of Donna L. Potter, deceased, whose date of death was September 15, 2024, is pending in the Circuit Court for Collier County, Florida, Probate Division, the address of which is 3315 Tamiami Trail East, Naples, FL 34112. The names and addresses of the personal representative and the personal representative's attorney are set forth below.

All creditors of the decedent and other persons having claims or demands against decedent's estate on whom a copy of this notice is required to be served must file their claims with this court ON OR BEFORE THE LATER OF 3 MONTHS AFTER THE TIME OF THE FIRST PUBLICATION OF THIS NOTICE OR 30 DAYS AFTER THE DATE OF SERVICE OF A COPY OF THIS NOTICE ON THEM.

All other creditors of the decedent and other persons having claims or demands against decedent's estate must file their claims with this court WITHIN 3 MONTHS AFTER THE DATE OF THE FIRST PUBLICATION OF THIS NOTICE.

The personal representative has no duty to discover whether any property

held at the time of the decedent's death by the decedent or the decedent's surviving spouse is property to which the Florida Uniform Disposition of Community Property Rights at Death Act as described in ss. 732.216-732.228, applies, or may apply, unless a written demand is made by a creditor as specified under s. 732.2211, Florida Statutes.

ALL CLAIMS NOT FILED WITHIN THE TIME PERIODS SET FORTH IN FLORIDA STATUTES SECTION 733.702 WILL BE FOREVER BARRED.

NOTWITHSTANDING THE TIME PERIOD SET FORTH ABOVE, ANY CLAIM FILED TWO (2) YEARS OR MORE AFTER THE DECEDENT'S DATE OF DEATH IS BARRED.

The date of first publication of this notice is December 27, 2024.

Ancillary Personal Representative:
Mary C. Potter
18325 Brightlingsea Place
South Bend, IN 46637

Attorney for Personal Representative:
/s/ W. Jeffrey Cecil, Esq.
W. Jeffrey Cecil Esq.
jcecil@porterwright.com
flprobate@porterwright.com
Florida Bar No. 0986135
Porter Wright Morris & Arthur LLP
9132 Strada Place,
Suite 301
Naples, FL 34108
Telephone: 239-593-2950
Dec. 27, 2024; Jan. 3, 2025

24-02226C

SECOND INSERTION

NOTICE TO CREDITORS
IN THE CIRCUIT COURT FOR COLLIER COUNTY, FLORIDA
PROBATE DIVISION
File No. 2024-CP-003329
Division Probate
IN RE: ESTATE OF BARBARA G. CASEY,
Deceased.

The administration of the estate of Barbara G. Casey, deceased, whose date of death was October 26, 2024, is pending in the Circuit Court for Collier County, Florida, Probate Division, the address of which is 3315 Tamiami Trail East, Ste. 102, Naples, Florida 34112. The names and addresses of the personal representative and the personal representative's attorney are set forth below.

All creditors of the decedent and other persons having claims or demands against decedent's estate must file their claims with this court WITHIN 3 MONTHS AFTER THE DATE OF THE FIRST PUBLICATION OF THIS NOTICE.

ALL CLAIMS NOT FILED WITHIN THE TIME PERIODS SET FORTH IN FLORIDA STATUTES SECTION 733.702 WILL BE FOREVER BARRED.

NOTWITHSTANDING THE TIME PERIODS SET FORTH ABOVE, ANY CLAIM FILED TWO (2) YEARS OR MORE AFTER THE DECEDENT'S DATE OF DEATH IS BARRED.

The date of first publication of this notice is December 27, 2024.

Personal Representative:
William P. Casey
4601 Gulf Shore Blvd. N., #8
Naples, FL 34103

Attorneys for Personal Representative:
DUNWODY WHITE & LANDON, P.A.
Daniel K. Capes, Esq.
Florida Bar Number: 106429
4001 Tamiami Trail North, Suite 200
Naples, FL 34103
Telephone: (239) 263-5885
Fax: (239) 262-1442
Dec. 27, 2024; Jan. 3, 2025

24-02222C

THIRD INSERTION

NOTICE OF ADMINISTRATIVE COMPLAINT

To: Brenda L. Darrant
Case No.: CD202408503/
D 3325619/3402380

An Administrative Complaint to impose an administrative fine has been filed against you. You have the right to request a hearing pursuant to Sections 120.569 and 120.57, Florida Statutes, by mailing a request for same to the Florida Department of Agriculture and Consumer Services, Division of Licensing, Post Office Box 5708 Tallahassee, Florida 32314-5708. If a request for hearing is not received by 21 days from the date of the last publication, the right to hearing in this matter will be waived and the Department will dispose of this cause in accordance with law.
Dec. 20, 27, 2024; Jan. 3, 10, 2025

24-02190C

WHEN PUBLIC NOTICES REACH THE PUBLIC, EVERYONE BENEFITS.

Some officials want to move notices from newspapers to government-run websites, where they may not be easily found.

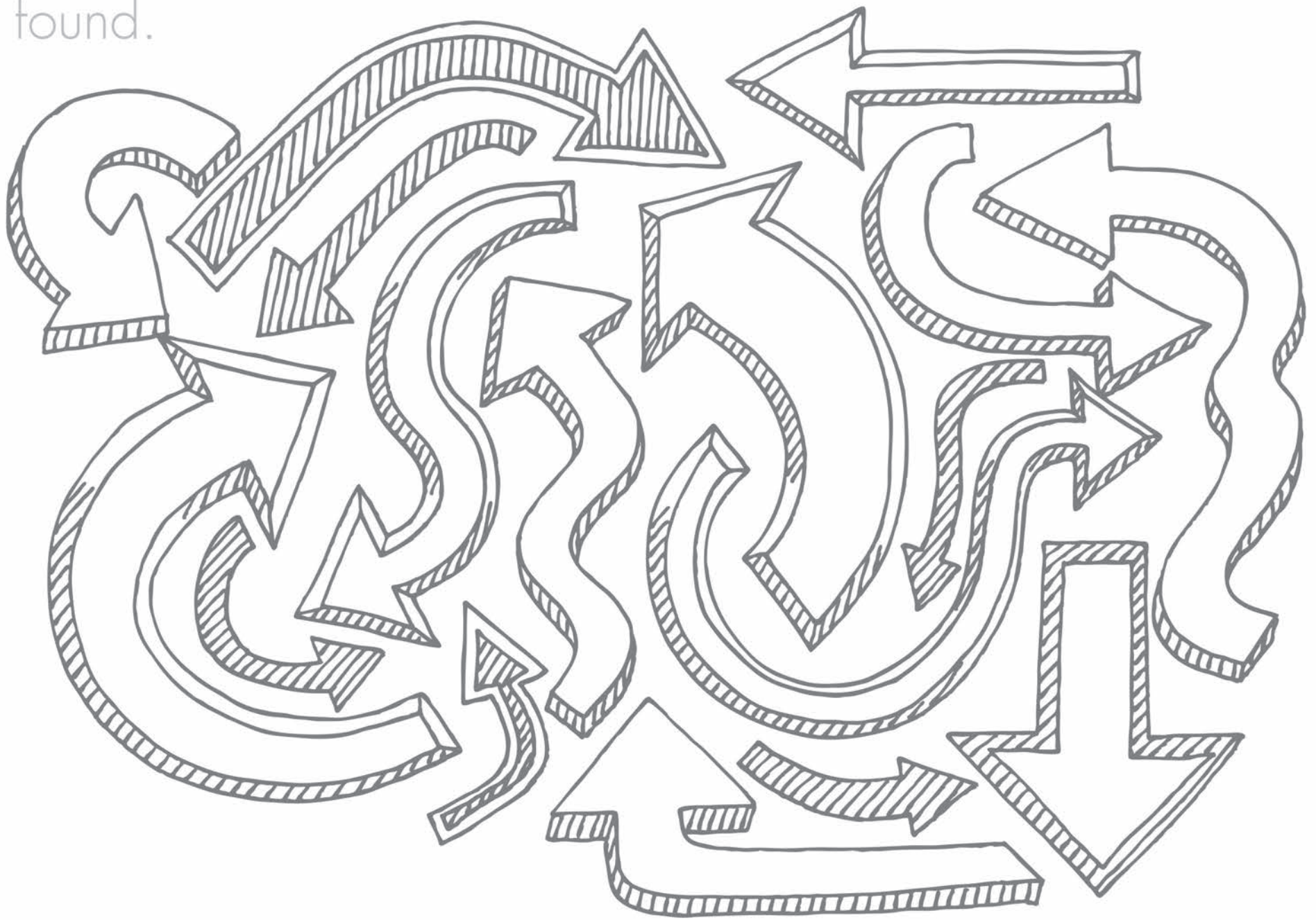

2 OUT OF 3

U.S. adults read a newspaper in print or online during the week.



Why try to fix something that isn't broken?

Keep Public Notices in Newspapers.



www.newsmediaalliance.org

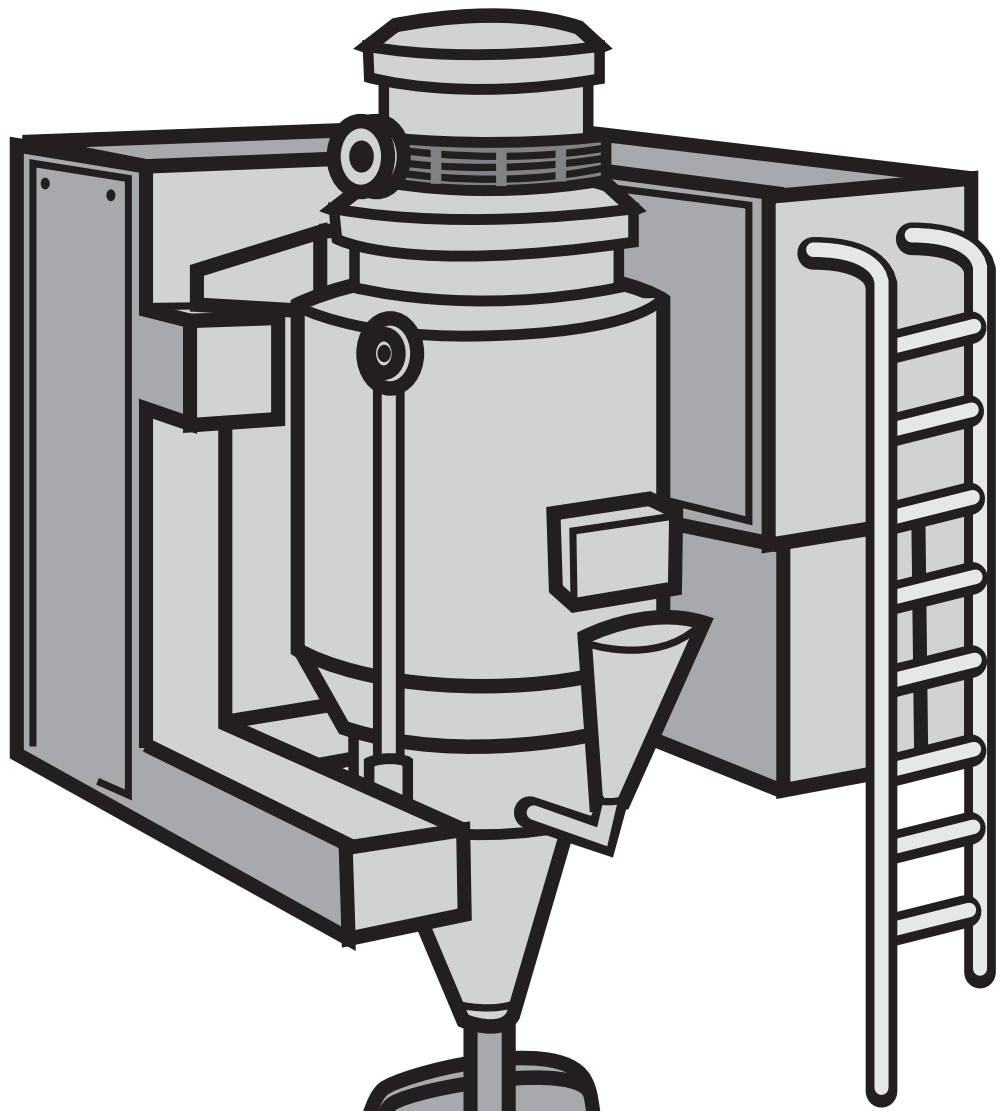

A special printing of
a classic story illustrating
the importance of
protecting capitalism.

TOM SMITH AND HIS INCREDIBLE BREAD MACHINE

By R.W. Grant

Illustrations by Austin McKinley

This is the legend of a man whose name
Was a household word: a man whose fame
Burst on the world like an atom bomb.
Smith was his last name; first name: Tom.

The argument goes on today.
"He was a villain," some will say.
"No! A hero!" others declare.
Or was he both? Well, I despair;
The fight will last 'til kingdom come;
Was Smith a hero? Or was Smith a bum?
So, listen to the story and it's up to you
To decide for yourself as to which is true!

Now, Smith, an inventor, had specialized
In toys. So people were surprised
When they found that he instead
Of making toys, was baking bread!
The news was flashed by CBS
Of his incredible success.
Then NBC jumped in in force,
Followed by the Times, of course.
The reason for their rapt attention,
The nature of his new invention,
The way to make bread he'd conceived
Cost less than people could believe!
And not just make it! This device
Could in addition wrap and slice!
The price per loaf, one loaf or many:
The miniscule sum of under one penny!

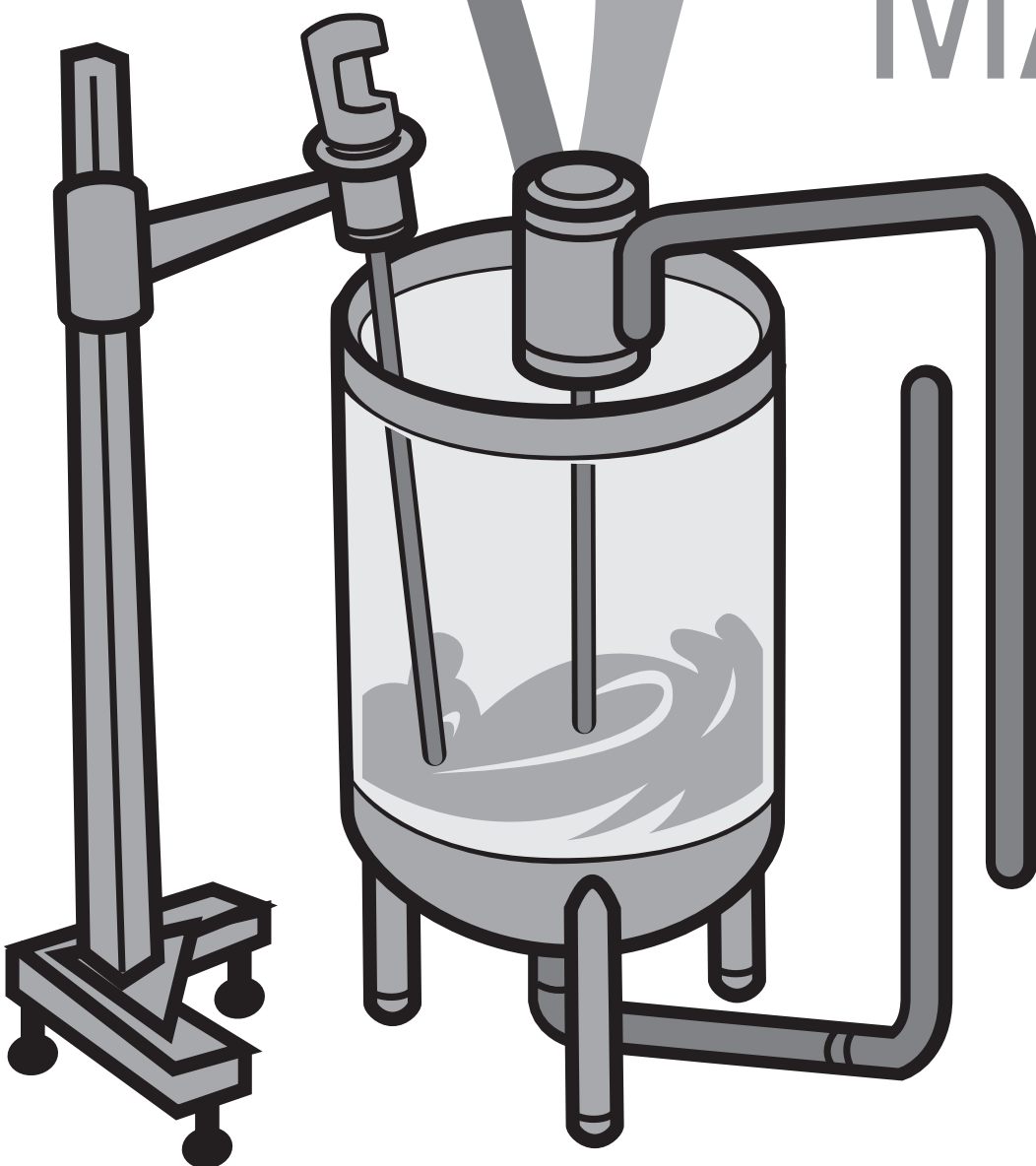

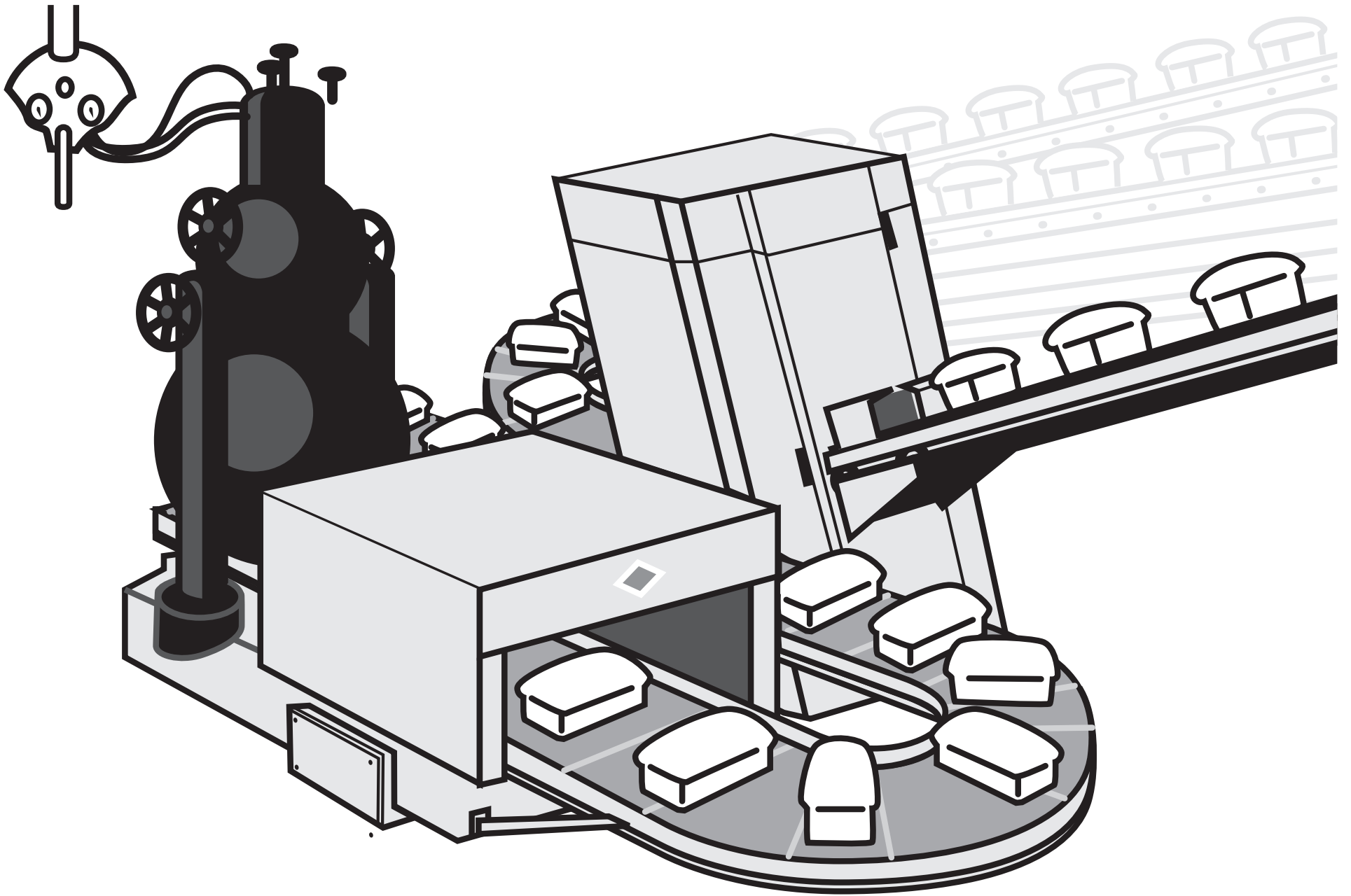

Can you imagine what this meant?
Can you comprehend the consequent?
The first time yet the world well fed!
And all because of Tom Smith's bread!

Not the last to see the repercussions
Were the Red Chinese, and, of course, the
Russians,
For Capitalist bread in such array

Threw the whole red block into black dis-
may!
Nonetheless, the world soon found
That bread was plentiful the world
around.
Thanks to Smith and all that bread,
A grateful world was at last well fed!

But isn't it a wondrous thing
How quickly fame is flown?
Smith, the hero of today
Tomorrow, scarcely known!
Yes, the fickle years passed by.
Smith was a billionaire.

But Smith himself was now forgot,
Though bread was everywhere.
People, asked from where it came,
Would very seldom know.

They would simply eat and ask,
'Was not it always so?'

However, Smith cared not a bit,
For millions ate his bread,
And "Everything is fine," thought he.
"I'm rich and they are fed!"

Everything was fine, he thought?
He reckoned not with fate.
Note the sequence of events
Starting on the date
On which inflation took its toll,
And to a slight extent,
The price on every loaf increased:
It went to one full cent!

A sharp reaction quickly came.
People were concerned.
White House aide expressed dismay.
Then the nation learned
That Russia lodged a sharp protest.
India did the same.
"Exploitation of the Poor!"
Yet, who was there to blame?

And though the clamor ebbed and flowed,
All that Tom would say
Was that it was but foolish talk.
Which soon would die away.
And it appeared that he was right.
Though on and on it ran,
The argument went 'round and 'round
But stopped where it began.

There it stopped, and people cried,
"For heaven's sake, we can't decide!
It's relative! Beyond dispute,
There's no such thing as 'absolute'!
And though we try with all our might,
Since nothing's ever black or white,
All that we can finally say is
'Everything one shade of grey is!'
So people cried out, "Give us light!
We can't tell what's wrong from right!"

To comprehend confusion,
We seek wisdom at its source.
To whom, then did the people turn?
The Intellectuals, of course!

And what could be a better time
For them to take the lead,
Than at their International Conference
On Inhumanity and Greed.
For at this weighty conference,
Once each year we face
The moral conscience of the world—
Concentrated in one place.

At that mighty conference were
A thousand, more or less,
Of intellectuals and bureaucrats,
And those who write the press.
And from Yale and Harvard
The professors; all aware
The fate of Smith would now be known.
Excitement filled the air!

"The time has come," the chairman said
"To speak of many things:
Of duty, bread and selfishness,
And the evil that it brings.
For, speaking thus we can amend
That irony of fate
That gives to unenlightened minds
The power to create.



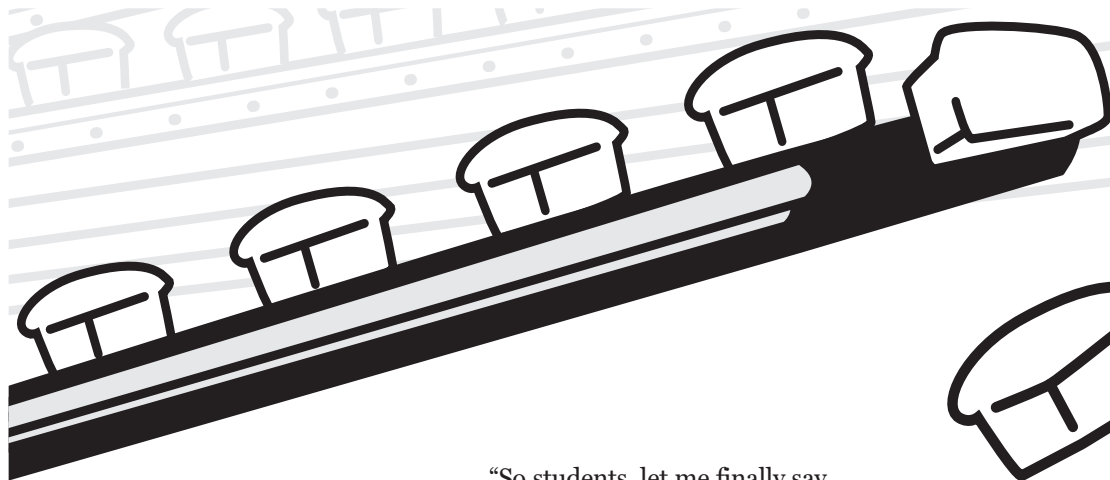

“Since reason tells us that it can’t,
Therefore let us start
Not by thinking with the mind,
But only with the heart!
Since we believe in people, then,”
At last the chairman said,
“We must meet our obligation
To see that they are fed!”

And so it went, one by one,
Denouncing private greed;
Denouncing those who’d profit thus
From other people’s need!

Then, suddenly each breath was held,
For there was none more wise
Than the nation’s foremost Pundit
Who now rose to summarize:

“My friends,” he said, (they all
exhaled)
“We see in these events
The flouting of the Higher Law—
And its consequence.
We must again remind ourselves
Just why mankind is cursed:
Because we fail to realize
Society comes first!”

“Smith placed himself above the
group
To profit from his brothers.
He failed to see the Greater Good,
Is Service, friends, to Others!”

With boldness and with vision,
then,
They ratified the motion
To dedicate to all mankind
Smith’s bread-and their devotion!

The conference finally ended.
It had been a huge success.
The intellectuals had spoken.
Now others did the rest.

The professors joined in all the
fuss,
And one was heard to lecture thus:
(For clarity, he spoke in terms
Of Mother Nature, birds and worms):

“That early birds should get the worm
Is clearly quite unfair.
Wouldn’t it much nicer be
If all of them would share?
But selfishness and private greed

Seem part of nature’s plan,
Which Mother Nature has decreed
For bird. But also Man?
The system which I question now,
As you are well aware,
(I’m sure you’ve heard the term
before
Is Business, Laissez-Faire!

“So students, let me finally say
That we must find a nobler way.
So, let us fix the race that all
May finish side-by-side;
The playing field forever flat,
The score forever tied.
To achieve this end, of course,
We turn to government-and force.
So, if we have to bring Smith do
As indeed we should,
I’m sure you will agree with me,
It’s for the Greater Good!”

Comments in the nation’s press
Now scorned Smith and his plunder:
“What right had he to get so rich
On other people’s hunger?”
A prize cartoon depicted Smith
With fat and drooping jowls
Snatching bread from hungry babes,
Indifferent to their howls.

One night, a TV star cried out,
“Forgive me if I stumble,
But I don’t think, I kid you not,
That Smith is very humble!”
Growing bolder, he leaped up,

(Silencing the cheers)
“Humility!” he cried to all—
And then collapsed in tears!

The clamor rises all about;
Now hear the politician shout:
“What’s Smith done, so rich to be?
Why should Smith have more than thee?
So, down with Smith and all his greed;
I’ll protect your right to need!”

Then Tom found to his dismay
That certain businessmen would say,
“The people now should realize
It’s time to cut Smith down to size,
For he’s betrayed his public trust
(And taken all that bread from us!)”

Well, since the Public does come first,
It could not be denied
That in matters such as this,
The public must decide.
So, SEC became concerned,
And told the press what it had learned:
“It’s obvious that he’s guilty
—Of what we’re not aware—
Though actually and factually
We’re sure there’s something there!”

And Antitrust now took a hand.
Of course it was appalled
At what it found was going on.
The “bread trust” it was called.

“Smith has too much crust,”
they said. “A deplorable condition
That Robber Barons profit thus
From cutthroat competition!”

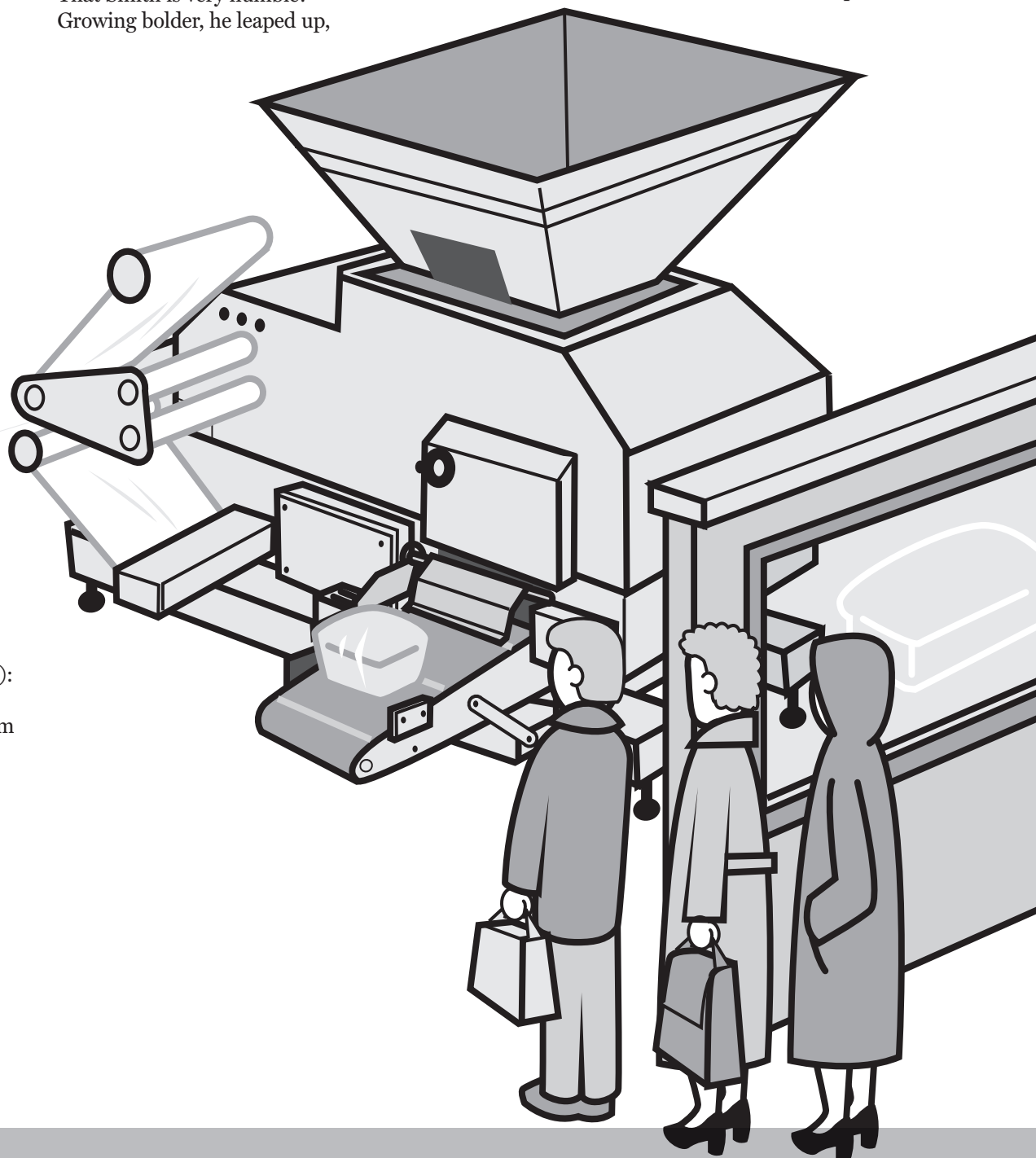

WELL!

This was getting serious!
So Smith felt that he must
Have a friendly interview
With SEC and 'Trust.
So, hat in hand, he went to them.
They'd surely been misled;
No rule of law had he defied.
But then their lawyer said:

"The rule of law, in complex times,
Has proved itself deficient.
We much prefer the rule of men.
It's vastly more efficient.

"So, nutshell-wise, the way it is,
The law is what we say it is!"

"So, let me state the present rules,"
The lawyer then went on,
"These very simple guidelines
You can rely upon:
You're gouging on your prices
If you charge more than the rest.
But it's unfair competition
If you think you can charge less!
"A second point that we would make,
To help avoid confusion:
Don't try to charge the same amount,
For that would be collusion!"

"You must compete—but not too much.
For if you do, you see,
Then the market would be yours—
And that's monopoly!
Oh, don't dare monopolize!
We'd raise an awful fuss,
For that's the greatest crime of all!
(Unless it's done by us!)"

"I think I understand," said Tom.
"And yet, before I go,
How does one get a job like yours?
I'd really like to know!"

The lawyer rose then with a smile;
"I'm glad you asked," said he.
"I'll tell you how I got my start
And how it came to be."

(His secretaries gathered 'round
As their boss did thus expound.)

*"When I was a lad going off to school,
I was always guided by this golden rule:
Let others take the lead in things, for
heaven's sake,
So if things go wrong—why, then it's their
mistake!"*
(*So if things go wrong—why, then it's their
mistake!*)

*"Following this precept it came to pass
I became the president of my senior class.
Then on to college where my profs extolled
The very same theory from the very same
mold!"*
(*The very same theory from the very same
mold!*)

*"Let others take the chances, and I would
go along.
Then I would let them know where they all
went wrong!
So successful was my system that then
indeed,
I was voted most likely in my class to suc-
ceed!"*

*(He was voted most likely in his class to
succeed!)*

*"Then out into the world I went, along
with all the rest,
Where I put my golden rule to the ulti-
mate test.
I avoided all of commerce at whatever the
cost—
And because I never ventured, then I also
never lost!"*
(*And because he never ventured, then he
also never lost!*)

*"With this unblemished record then, I
quickly caught the eye
Of some influential people 'mongst the
powers on high.*

*And so these many years among the
mighty I have sat,
Having found my niche as a bureaucrat!"*
(*Having found his niche as a bureaucrat!*)

*"To be a merchant prince has never been
my goal,
For I'm qualified to play a more impor-
tant role:
Since I've never failed in business, this of
course assures
That I'm qualified beyond dispute to now
run yours!"*
(*That he's qualified beyond dispute to now
run yours!*)

"Thanks; that clears it up," said Tom.

The lawyer said, "I'm glad!
We try to serve the public good.
We're really not so bad!"

"Now, in disposing of this case,
If you wish to know just how,
Go up to the seventh floor;
We're finalizing now!"

So, Tom went to the conference room
Up on the seventh floor.
He raised his hand, about to knock,
He raised it—but no more—
For what he overheard within
Kept him outside the door!
A sentence here, a sentence there—
Every other word—
He couldn't make it out (he hoped),
For this is what he heard:

"Mumble, mumble, let's not fumble!
Mumble, mumble, what's the charge?
Grumble, grumble, he's not humble?
Private greed? Or good of all?"

"Public Interest, Rah! Rah! Rah!
Business, Business, Bah! Bah! Bah!"

"Say, now this now we confess
That now this now is a mess!
Well now, what now do we guess?
Discharge? Which charge would be best?"

"How 'bout 'Greed and Selfishness'?
Oh, wouldn't that be fun?
It's vague enough to trip him up
No matter what he's done!"

"We don't produce or build a thing!
But before we're through,
We allow that now we'll show Smith how
We handle those who do!"

"We serve the public interest;
We make up our own laws;
Oh, golly gee, how selflessly
We serve the public cause!"

"For we're the ones who make the rules
At 'Trust and SEC,
So bye and bye we'll get that guy;
Now, what charge will it be?"

"Price too high? Or price too low?
Now, which charge will we make?
Well, we're not loath to charging both
When public good's at stake!"

"But can we go one better?
How 'bout monopoly?
No muss, no fuss, oh clever us!
Right-O! Let's charge all three!"

"But why stop here? We have one more!
Insider Trading! Number four!
We've not troubled to define
This crime in any way so,
This allows the courts to find
Him guilty 'cause we say so!"

So, that was the indictment.
Smith's trial soon began.
It was a cause célèbre
Which was followed' cross the land.
In his defense Tom only said,
"I'm rich, but all of you are fed!
Is that bargain so unjust
That I should now be punished thus?"

Tom fought it hard all the way.
But it didn't help him win.
The jury took but half an hour
To bring this verdict in:

"Guilty! Guilty! We agree!
He's guilty of this plunder!
He had no right to get so rich
On other people's hunger!"

"Five years in jail!" the judge then said.
"You're lucky it's not worse!
Robber Barons must be taught
Society Comes First!
As flies to wanton boys," he leered,
"Are we to men like these!
They exploit us for their sport!
Exploit us as they please!"

The sentence seemed a bit severe,
But mercy was extended.
In deference to his mother's pleas,
One year was suspended.
And what about the Bread Machine?
Tom Smith's little friend?
Broken up and sold for scrap.
Some win. Some lose. The end.

EPILOGUE

Now, bread is baked by government.
And as might be expected,
Everything is well controlled—
The public well protected.

True, loaves cost ten dollars each.
But our leaders do their best.
The selling price is half a cent.
Taxes pay the rest!

